

Feb. 27, 1968

D. H. LA VANGE

3,370,732

CAP SEAL

Filed Feb. 16, 1967

FIG. 1.

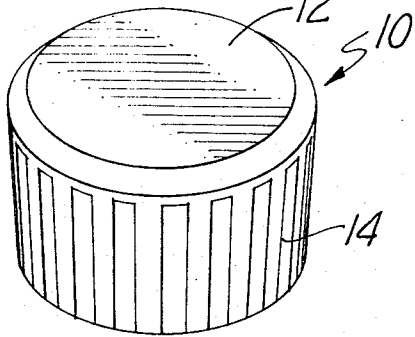

FIG. 3.

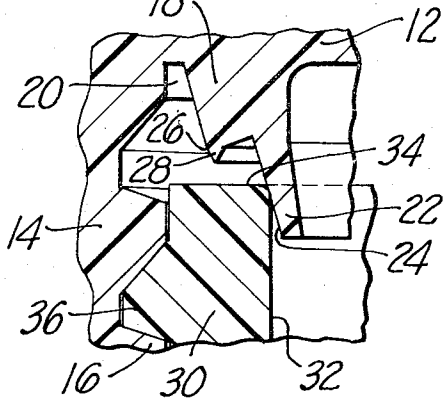

FIG. 2.

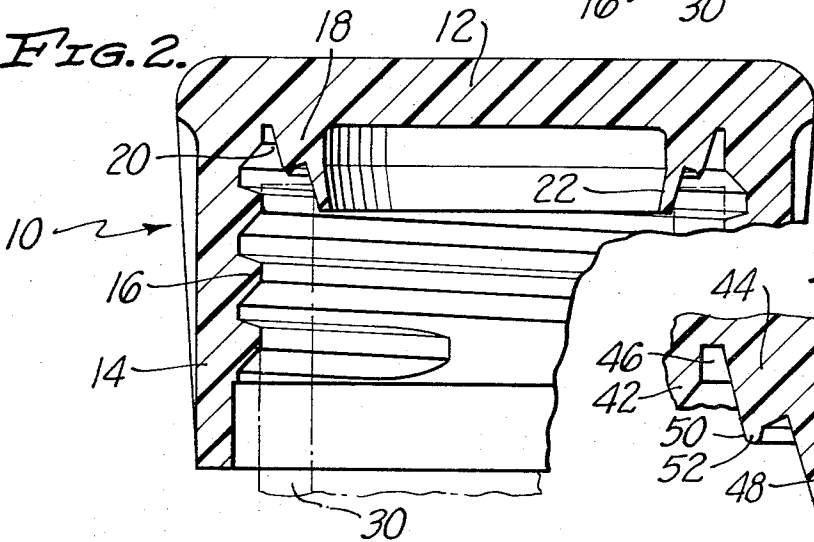

FIG. 6.

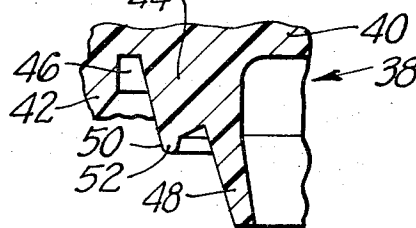

FIG. 4.

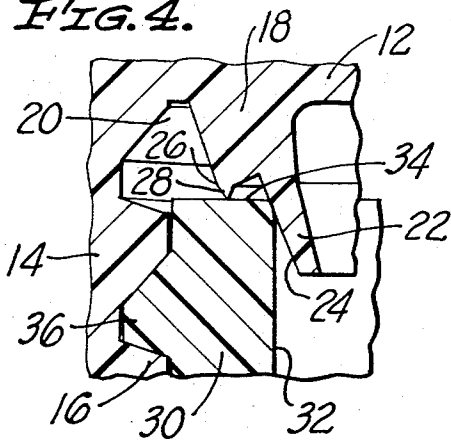
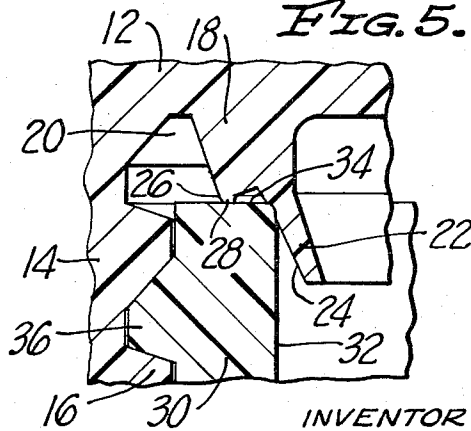

FIG. 5.



INVENTOR
DONALD H. LA VANGE
BY
EDWARD D. O'BRIAN
ATTORNEY

1

3,370,732
CAP SEAL

Donald H. La Vange, East Douglas, Mass., assignor to Polytop Corporation, Slatersville, R.I., a corporation of Massachusetts

Filed Feb. 16, 1967, Ser. No. 616,674
3 Claims. (Cl. 215-40)

2

ABSTRACT OF THE DISCLOSURE

Assuming the cap seal is oriented to be positioned upon an upright neck, the cap seal has an interior downwardly extending circular resilient ring. Integrally formed with this ring and downwardly and inwardly directed with respect to this ring is a sealing and deflecting cone which is adapted to engage upon the interior of the bottle neck opening. Such engagement causes inward deflection of both resilient ring and the cone. On the lower face of the ring is a downwardly extending sealing lip positioned to engage the top surface of the bottle neck outward from its opening. Since the resilient ring is attached to the remainder of the cap on its upper end, it is rigid in that direction, but since it is separated from the cap skirt in the radial direction, deflection of the ring caused by engagement of the cone within the bottle opening causes deflection of the sealing lip toward engagement of the top of the bottle neck to thrust it down into firm sealing engagement therewith.

Background

This invention is directed to a cap seal and particularly to a cap seal which is adapted to be sealingly attached to a bottle neck. The sealing between the cap and the bottle neck comprise two different related and interacting sealing engagements with the bottle neck to assure positive seal. The cap seal of this invention is applicable to plain closure caps, to seal the contents of the bottle therein and to dispensing closures which have a bottle sealing on the bottle neck and have controlled dispensing means positioned on the cap.

Since the sealing closure of bottle necks has been a problem for many years, there is much prior art on the subject. Of particular pertinence are two prior classes of seals. Wilson Patent No. 3,163,337 discloses a resilient seal cone formed directly on the cap. That seal cone engages on the interior of the bottle neck opening so that its deflection upon installation of the closure causes sealing. That seal cone is similar to one of the components of the seal of this invention. Mart Patent No. 2,828,895 discloses an annular sealing ridge which is directly fastened to the body of the cap and which engages directly upon the top of the bottle neck. It also resembles a portion of the present seal. Neither of these prior seals is as wholly effective for sealing purposes as the present structure, because of the inter-related action in the present structure. Both the sealing cone and the sealing lip of the present invention cause sealing, and the deflection of the cone causes deflection of the lip to improve lip sealing. The prior structures are directly attached to the cap while the present sealing means are mounted on the lower end of the resilient sealing ring and this lower end is radially separated from the skirt of the cap to permit the deflection which enhances sealing.

Summary

The cap seal of this invention includes a cap body and securing means to secure the cap body with respect to the neck to be closed. The neck to be closed necessarily includes an internal opening and an upper face. Attached to the body of the cap is a circular resilient ring which ex-

tends toward the opening. This resilient ring is attached to the cap body away from the bottle opening and is outwardly radially free on its end toward the bottle opening. The two cooperating sealing means are formed on the free end of the ring. The sealing lip is so positioned as to extend interiorly of the bottle neck. It is provided with an interfering cone so that first engagement occurs before the cap is fully in place. During further installation, the conical or substantially conical angle on the exterior of the cone causes inward deflection on the entire lower end of the resilient ring. The downwardly extending sealing lip is directed toward the top surface around the opening to be sealed, and is positioned so that the deflection of the cone causes deflection of the ring and motion of the sealing lip toward the surface against which it is to be sealed. This inward bending of the cone and the resultant motion of the sealing lip toward the surface against which it will be sealed enhances the sealing. Upon continued installation of the cap, this motion continues until both the sealing cone and sealing lip are in sealing engagement with the opening and the sealing surface around it. This cooperation and mechanical interaction between the two seals permits the cap seal of this invention to seal bottle necks which are not perfect. Concentricity of the opening and circularity of it vary. Such makes difficulty when trying to seal with a deflecting cone alone. Furthermore, the sealing end face of the bottle neck is not cut off perfectly square with respect to an axis of the bottle neck. This makes sealing difficult with a plain face seal, but the interacting cooperating sealing cone and sealing lip of the present cap seal permit proper sealing even when bottle necks are not perfect.

Accordingly, it is an object of this invention to provide a cap seal which is capable of sealing a bottle neck, even when the bottle neck is not perfect. It is a further object of this invention to provide a cap seal which has a deflecting cone which deflects upon interengagement with a bottle neck and causes a sealing lip to move towards sealing engagement. It is a further object of this invention to provide a cap seal which can be economically manufactured of resilient material so that a circular resilient ring carries a deflecting cone which causes deflection of a portion of the ring and causes a sealing lip on the ring to move toward sealing engagement with a bottle neck. Other objects and advantages of this invention will become apparent from the following portion of the specification, the claims and the attached drawings.

Description of the drawing

FIG. 1 is an isometric view of a cap embodying the sealing structure of this invention.

FIG. 2 is an enlarged transverse section through the cap of FIG. 1 showing the sealing structure therein.

FIG. 3 is a further enlarged section, with parts broken away, showing the details of the sealing structure and showing the inter-relationship of the sealing structure with a bottle neck upon first contact of the sealing structure with the bottle neck.

FIG. 4 is similar to FIG. 3, showing the cooperation at a further stage of contact between the seal and the bottle neck.

FIG. 5 is a further view similar to FIG. 3 showing the final sealing position and interengagement between the cap seal and the bottle neck.

FIG. 6 is a fragmentary sectional view of a further embodiment of the cap seal of this invention.

Description

In the preferred embodiment of FIGS. 1 through 5, a cap having the cap seal of this invention is generally indicated at 10. The cap is illustrated as having a body which includes top 12 and skirt 14. Threads 16 are illus-

3

trated on the interior of skirt 14. Cap 10 with its top, skirt and threads is an illustrative embodiment for showing the general locus of the cap seal in this invention. Instead of the solid top 12, the top 12 may carry a dispensing spout as is shown in Wilson Patent No. 3,163,337. However, such a dispensing spout does not affect the sealing structure, and thus is not directly related to the seal. Furthermore, while threads 16 are illustrated interiorly of the skirt, and the threads 16 are continuous, other fastening means for securing the cap 10 upon a bottle neck may be employed. For example, interrupted threads or a snap-over ridge may be used interiorly of skirt 14 for securement purposes. The only requirement of the securing means is that sufficient axial force be provided between the cap and the bottle neck to make the seal effective. Screw threads are preferred, as illustrated. Since cap 10 is generally circular, it has a vertical axis which forms the axis of revolution in skirt 14.

Downwardly extending circular resilient ring 18 is preferably integrally formed within the body of cap 10. It extends downward from the body and is exteriorly separated from the skirt 14 by means of annular space 20. Space 20 may be formed at the upper end of threads 16 or may be a space extending upwardly beyond the termination of the threaded portion. FIGS. 3, 4 and 5 are taken through different axial planes and illustrate these different circumstances, which are caused by the lead of the threads. Formed on ring 18 is downwardly and inwardly extending sealing and deflecting cone 22. It is shown in its undeflected position in FIG. 3. Cone 22 has a substantially conical exterior surface 24.

Also formed upon ring 18 is downwardly extending sealing lip 26. Lip 26 is formed outwardly from the exterior surface 24 of the cone. Lip 26 may terminate in the juncture of the two conical surfaces illustrated as defining the lip and the exterior surface of ring 18 or it may terminate in an extended annular sealing ridge 28 which extends below the lower conical defining surface of ring 18. In the embodiment of FIGS. 1 through 5 ridge 28 is in the form of a sharp edged annular ridge extending downwardly from lip 28.

A bottle neck is illustrated in FIGS. 3, 4 and 5 to illustrate the cooperation between the cap 10 and the sealing structure with the bottle neck. It is clear, however, that the cap seal is useful in other similar structures, in addition to bottles. Bottle neck 30 has an interior opening defined by interior surface 32. Bottle neck 30 terminates in top surface 34 and has exterior threads 36 which cooperate with threads 16 to install and retain cap 10 upon bottle neck 30.

Cap 10, with its sealing structure, is preferably integrally formed of a resilient synthetic polymer composition material. For example, polyethylene is particularly suitable for the cap 10. Polyethylene and similar synthetic polymer composition material permit injection molding of the cap 10 so that it can be inexpensively produced in large quantities. The physical requirements that the cap 10 be reasonably rigid as far as its top 12 and skirt 14 are concerned so that the cap properly retains its form when it is screwed upon the bottle neck. However, the thicker sections of the top and skirt of the cap can provide for the rigidity. Resiliency is desired in the ring 18 as well as cone 22 and sealing lip 26. Therefore, the lighter sections of those portions provide the desired resiliency.

FIGS. 3, 4 and 5 illustrate the installation of the cap 10 upon bottle neck 30. In FIG. 3, the cap is screwed onto the neck to the point where exterior surface 24 of the sealing and deflecting cone 22 comes into first contact with the bottle neck. The cone is so dimensioned that its smaller, lower end easily fits within and clears within the interior surface 32 and this contact occurs part way up the exterior surface 24. Furthermore, this first contact occurs before lip 26 or its ridge 28 are in contact with top surface 34. As the cap 10 is continued to be screwed down upon bottle neck 30, the angularity of

4

the conical exterior surface 24 causes engagement between the juncture of the surfaces 32 and 34 with the conical surface 24. Such continued installation of cap 10 causes an inward radial thrust upon cone 22. Since the lower end of ring 18 is radially free, inward motion of cone 22 causes twisting of the bottom end of ring 18. This twisting includes inward motion of the lower right hand side of the ring as seen in FIGS. 3 through 5 and downward and rightward motion of lip 26 and ridge 28. Of course the external surface 24 need not be purely conical, but any tapered surface which reacts to the bottle neck in such a manner as to cause this twisting in the lower end of ring 18 is suitable. This twisting is permitted because the bottom end of ring 18 is free and radially unrestrained by radial connections to the skirt 14 of cap 10.

FIG. 4 illustrates the point of installation wherein ridge 28 just touches surface 34. In this position some twisting of the bottom end of the ring 18 has already occurred and lip 26 with its ridge 28 had been moved slightly downward and inward. Sealing contact is already accomplished between surfaces 24 and the upper interior corner of the bottle neck opening. Further tightening, to the point illustrated in FIG. 5, causes further relative downward axial motion of cap 10 with respect to the bottle neck. This causes upward thrust upon the lip 26 and its ridge 28 at the same time the upper interior of the corner of the bottle neck is thrusting cone 22 in the inward direction to cause twisting of ring 18 to cause downward thrust of lip 26 and ridge 28. This combined action produces a seal at lip 26 which supplements and may be superior to the seal obtained between cone 22 and the upper interior corner of the bottle.

Furthermore, the seal of lip 26 is able to properly seal against top surface 34 of the bottle neck which is not square with respect to the axis. Wider tolerances in bottle neck cutoff are still sealable with the cap seal of this invention. In addition, lack of perfect concentricity of interior surface 32 which defines the bottle neck opening with respect to threads 36 on which cap 10 is mounted does not as seriously affect the seal because of the double operative sealing action of this cap seal.

As final tightening occurs to the final closure of FIG. 5, the upward thrust of the bottle neck upon the lip 26 substantially returns it to its original position so that all of the downward deflection of the lip 26 and ridge 28 are returned as compressive sealing forces at the seal point. This upward force upon the lip 26 resulting from its engagement with top surfaces 34 tends to swing the ring somewhat back toward its original unstressed position, and this enhances sealing between the upper interior corner of the bottle neck opening and the exterior surface 24 of that cone. It can be seen that with this construction the lower end of ring 18 must be separated from skirt 14 so that the outer side of the ring is radially free to permit the above-described motion. However, ring 18 cannot be completely free because the vertical forces from the cap body down through the neck are the forces which initiate and ultimately produce the sealing forces. Thus, in the axial direction, the ring receives axial sealing forces from the body of the cap.

In the embodiment shown in FIG. 6, cap 38 is virtually identical to cap 10. Cap 38 has top 40, skirt 42 and ring 44, the same as cap 10. It has a space 46 separating the ring from the skirt. This permits the lower end of ring 44 to be resiliently deflectable. The lower end of ring 44 terminates in a downwardly and inwardly extending cone 48 and a downwardly extending lip 50 which is positioned outwardly from the cone. The engagement area of lip 50 is bead-like ridge 52. It is this portion that is different than that illustrated with respect to cap 10. Bead-like ridge 52 is rounded on its lower contacting edge to give a larger contacting area. Such is preferred in some installations.

The installation of cap 38 is identical to that of cap 10. First cone 48 engages in the interior of the bottle neck

5

opening causing twisting of the lower portion of ring 44. This twisting moves ridge 52 toward the end of the bottle neck. Further tightening and contact by ridge 52 with the end of the bottle neck stresses the ring 44 to partially return to its original position and thereby increase the loading on cone 48 as well as produce sealing engagement at ridge 52.

The tightening torque of cap 10 or 38 is as low as possible due to the nature of the sealing structure. With resilient structures such as these, excessive tightening forces cause considerable distortion of the cap. Distortion is objectionable, and is especially objectionable where the cap also includes dispensing structure. In such cases distortion is very objectionable because it causes leakage to occur in the dispensing structure. Thus, it is important to cause sealing of the cap with respect to the bottle neck at sufficiently low torques that a minimum of distortion of the cap occurs, especially in the caps employing dispensing structures.

This invention having been described in its preferred embodiment, it is clear that it is susceptible to numerous modifications and embodiments within the ability of those skilled in the art and without the exercise of the inventive faculty. Accordingly, the scope of this invention is defined by the scope of the following claims.

I claim:

1. In a bottle cap structure having a top, a skirt attached to said top so as to depend therefrom, and retaining means for retaining said cap structure on a bottle neck, said retaining means being located on said skirt, the improvement which comprises:

- a resilient, unitary sealing means for forming a seal with a bottle neck located on said top so as to be spaced from said skirt and so as to extend downwardly from said top within said skirt,
- said sealing means including a circular resilient ring, a lip and a deflecting cone,
- said ring being located on said top so as to extend downwardly therefrom within said skirt,

6

said ring being sufficiently thin so as to be capable of being deformed so as to be twisted inwardly towards the interior of said top,

said deflecting cone having a conical exterior surface and forming an extension of said ring extending downwardly and inwardly from the inner portion of the bottom thereof,

said lip forming an extension of said ring and extending downwardly from the outer portion of the bottom of said ring,

said deflecting cone being capable of engaging the interior of the top of a bottle neck as said bottle cap structure is applied to such a neck so as to be deformed generally inwardly, such deformation of the deflecting cone causing inward twisting of said ring because of its resiliency so as to move said lip in an inward and downward direction so that said lip will engage the top of said bottle neck.

2. A structure as claimed in claim 1 wherein: said lip includes a ridge formed on said ring so as to extend therefrom.

3. A structure as claimed in claim 1 wherein: said sealing means is integral with said top and said skirt of said cap structure.

References Cited

UNITED STATES PATENTS

2,914,206	11/1959	Lowen	-----	215-41
3,053,406	9/1962	Wandel	-----	215-41
3,053,407	9/1962	Lowen	-----	215-43
3,151,757	10/1964	Martin	-----	215-41
3,232,470	2/1966	Gibson	-----	215-43
3,281,000	10/1966	Lowen	-----	215-41
3,069,040	12/1962	Corsette	-----	215-41

JOSEPH R. LECLAIR, *Primary Examiner.*

R. PESHOCK, *Assistant Examiner.*