

March 20, 1951

H. H. ANDERSEN

2,546,082

BOILER

Filed July 25, 1946

4 Sheets—Sheet 1

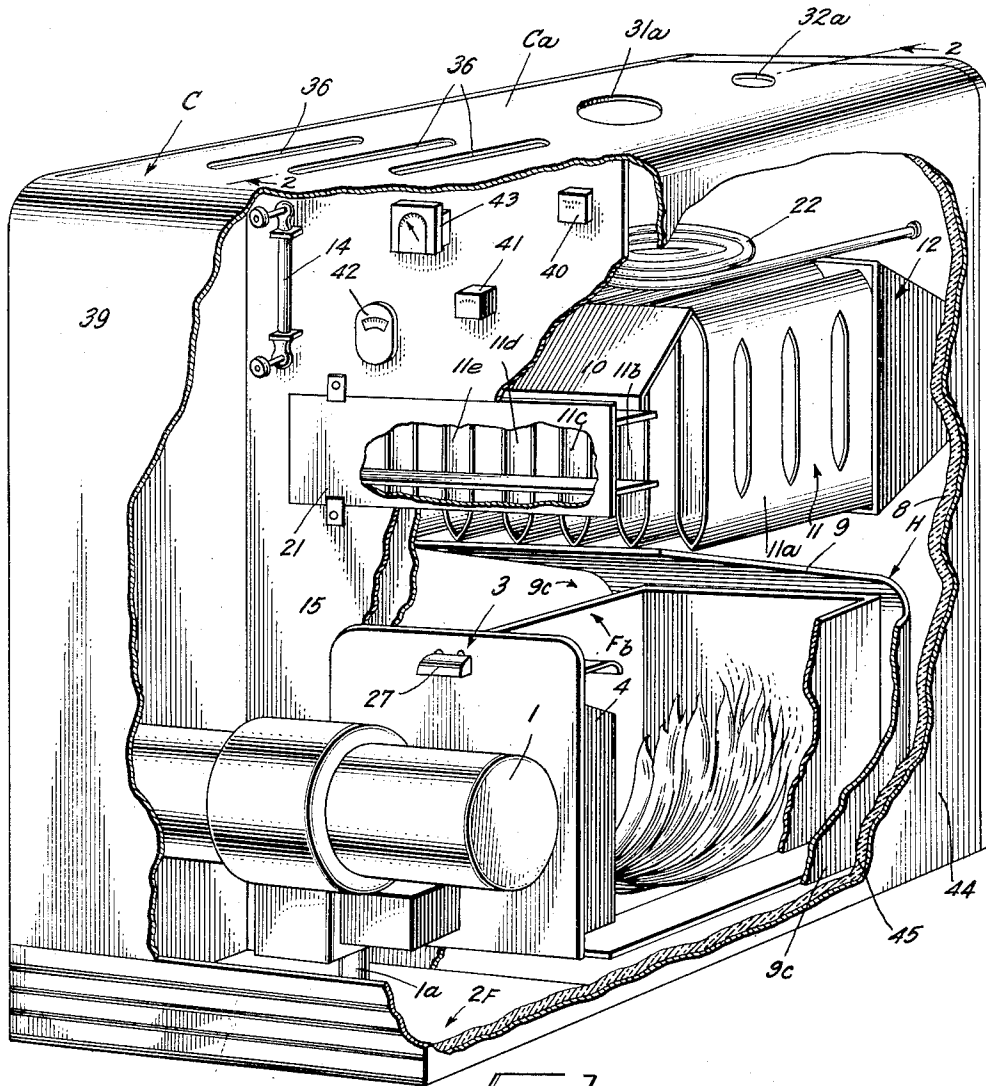

Fig. 1.

INVENTOR

HOTHER H. ANDERSON

BY *Fowler & Kennedy*
George W. Kennedy Jr.
ATTORNEY

March 20, 1951

H. H. ANDERSEN

2,546,082

BOILER

Filed July 25, 1946

4 Sheets-Sheet 2

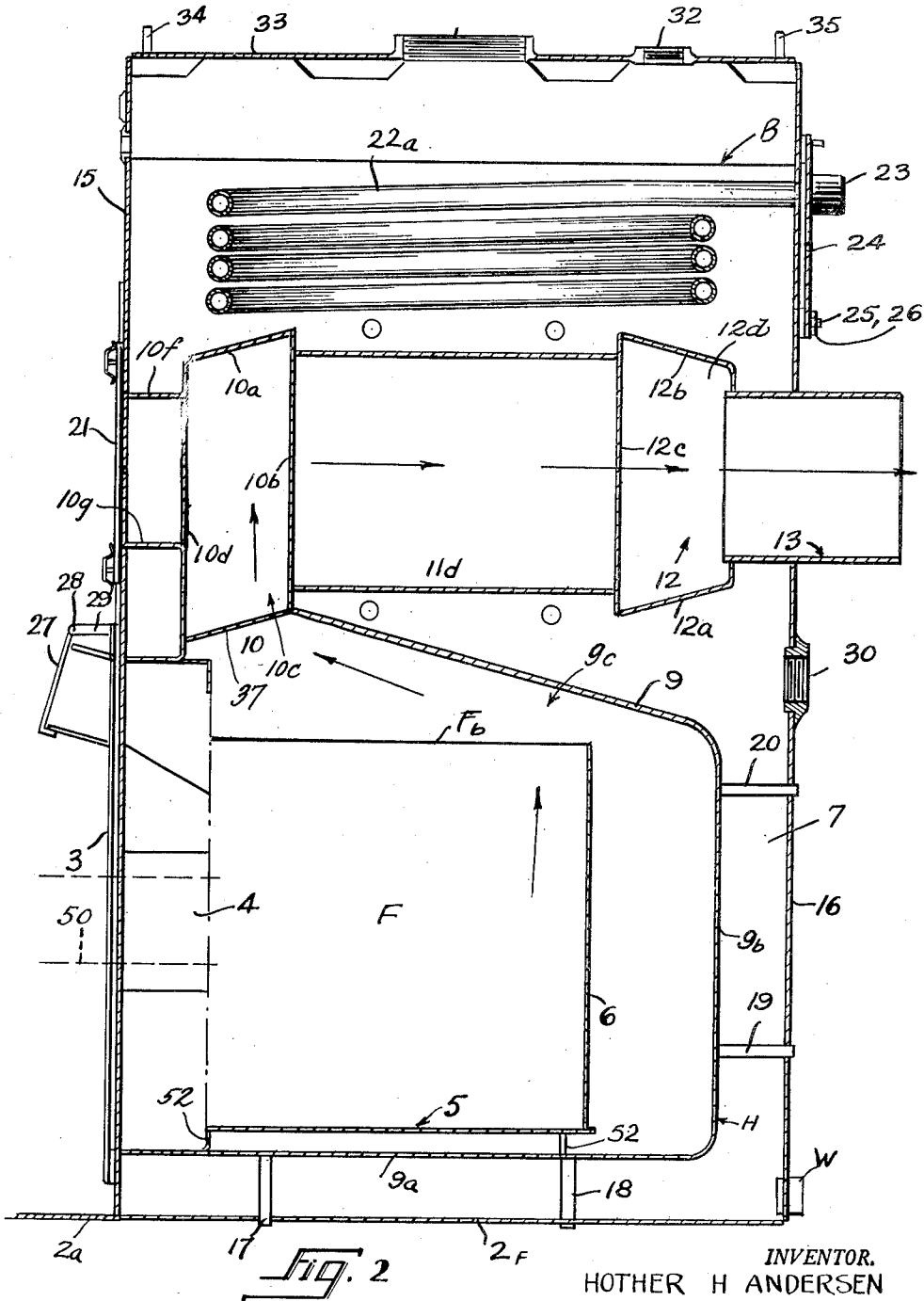

FIG. 2

INVENTOR.
HOTHER H ANDERSEN
BY
Maxwell E. Spanon
ATTORNEY

March 20, 1951

H. H. ANDERSEN
BOILER

2,546,082

Filed July 25, 1946

4 Sheets-Sheet 3

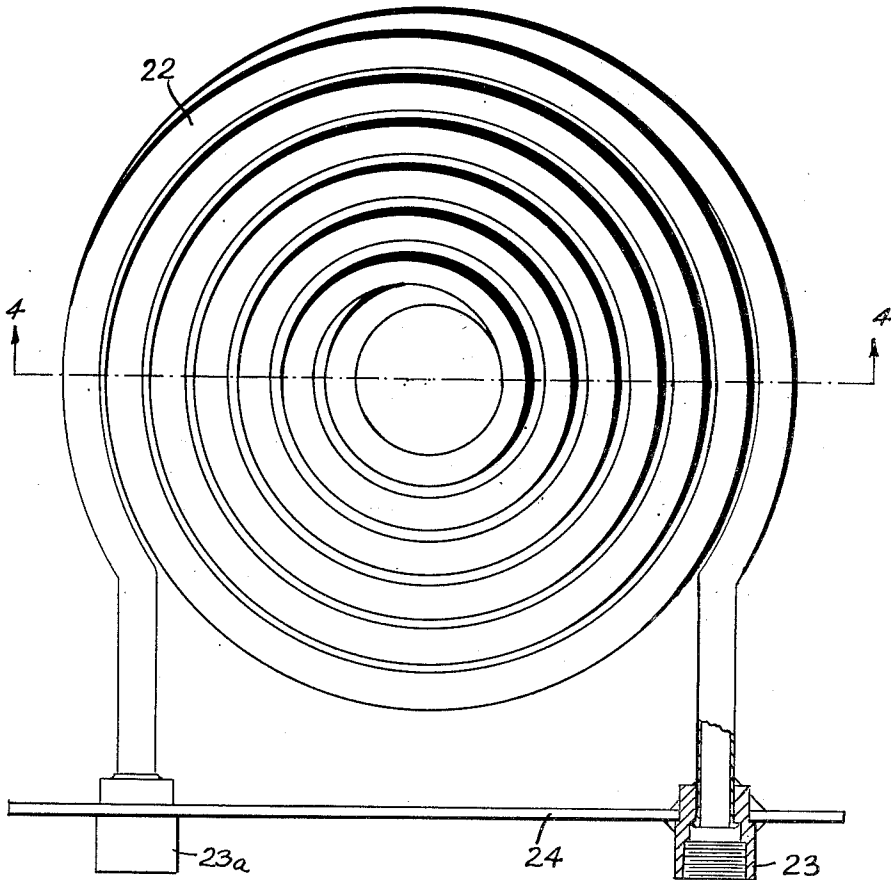

Fig. 3

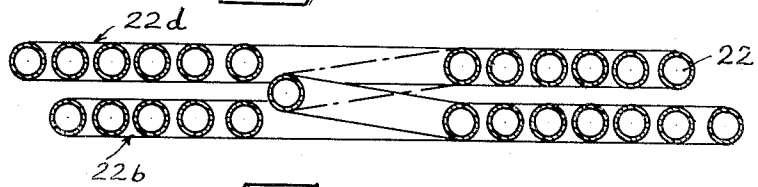

Fig. 4

INVENTOR.
HOTHER H ANDERSEN

BY
Michael Sparrow

March 20, 1951

H. H. ANDERSEN
BOILER

2,546,082

Filed July 25, 1946

4 Sheets-Sheet 4

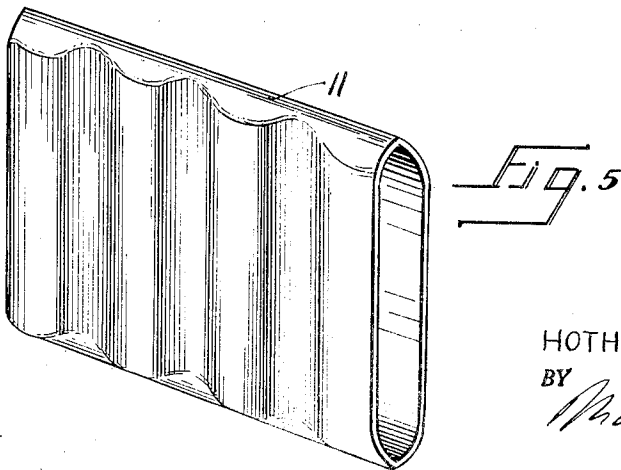
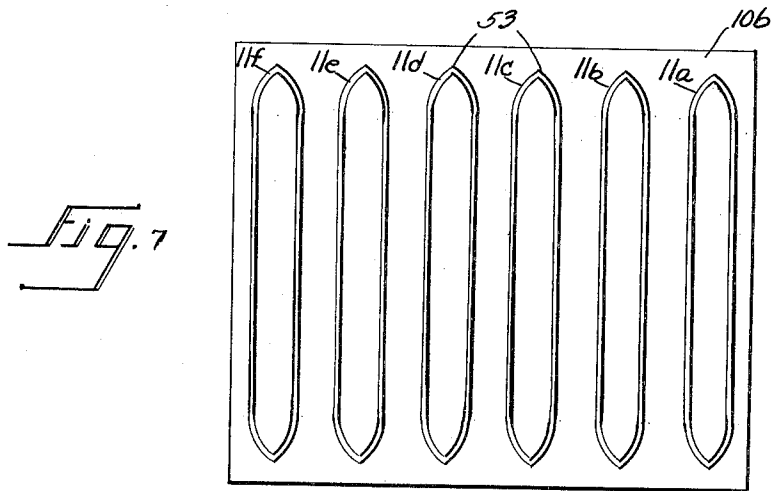
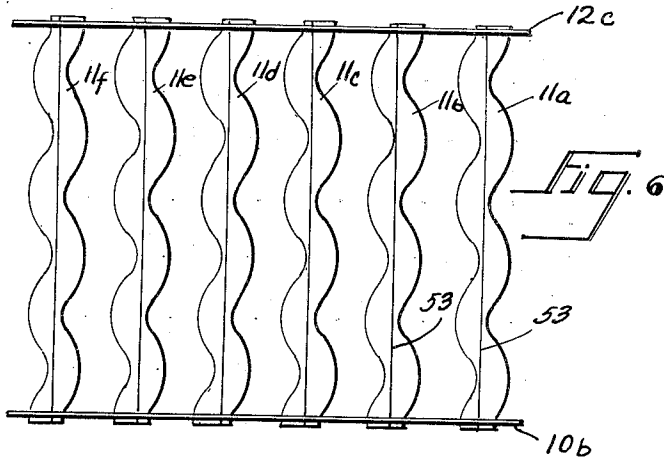

INVENTOR.
HOTHER H ANDERSEN
BY *Maxwell Sparrow*
ATTORNEY

UNITED STATES PATENT OFFICE

2,546,082

BOILER

Hother H. Andersen, New York, N. Y., assignor to
Atlantic Development Company, Inc., Spring-
field, Mass., a corporation of Massachusetts

Application July 25, 1946, Serial No. 686,252

5 Claims. (Cl. 122—135)

1

This invention relates to boilers and, more particularly, to that type of boiler which is adapted for heating residential houses and small industrial establishments.

The demand for an inexpensive and compact heating boiler has, heretofore, never been effectively met and, today, with so much emphasis upon portability and compactness, the demand for an efficient but small boiler unit has been felt more acutely by boiler manufacturers. Furthermore, the bulk of the residential homes being built today are constructed in a manner such that only a relatively small space is allotted to the heating plant, and thus, there is, and has been for some time, a need for a small compact boiler unit. However, by reducing the size of the usual type of boiler unit, it has been found that the heating capacity and efficiency of the unit has also be reduced.

It is, therefore, a primary object of the present invention to provide a small inexpensive boiler unit which will have substantially the same heating capacity and efficiency rating as the existing larger type boiler units.

It is a further object of the invention to provide a boiler unit which is so compact that it may be completely assembled with its oil burner and controls and be transported as a factory-tested unit to the building in which it is to be operated.

Another object of the invention is to provide a boiler unit having component elements which are particularly adapted to be fabricated by modern high-speed production methods, such as machine welding, thereby to maintain the manufacturing cost of the unit at a minimum.

Yet another object of the invention is to provide a boiler unit having a flue construction which makes for inexpensive manufacture but, at the same time, is characterized by its ability to transfer heat efficiently.

Another object of the invention is to provide a boiler unit with flues which may be completely accessible, throughout their length, through a single boiler opening.

It is yet another object of the invention to provide a boiler unit having hot water supply coils which may be readily inserted into and removed from the unit without disassembling the same.

Yet another object of the present invention is to provide an oil-fired boiler unit which produces steam or hot water in an efficient, economical, and safe manner, and which is quiet in operation, due to minimization of pulsation and rumble.

With the above and other objects in view, as

2

will hereinafter appear, the invention comprises the devices, the combinations, and arrangements of parts hereinafter set forth and illustrated in the accompanying drawings of a preferred embodiment of the invention from which the several features of the invention and the advantages attained thereby will be readily understood by those skilled in the art.

Fig. 1 represents a perspective view, partly broken away, of a boiler unit incorporating therein the present invention.

Fig. 2 represents a vertical section taken substantially along the line 2—2 of Fig. 1 with various parts left out for clarity.

Fig. 3 represents a top plan view of a hot water coil used in connection with the present boiler.

Fig. 4 represents a sectional view of the hot water heating coil taken substantially along line 4—4 of Fig. 3.

Fig. 5 represents a perspective view of a flue of the type incorporated in the present boiler.

Fig. 6 represents a top plan view of a complete flue unit.

Fig. 7 represents a front end view of the flue unit disclosed in Fig. 6 with one of the headers removed.

Like reference characters refer to like parts in the different figures.

Referring now to the drawings which illustrate a preferred embodiment of the invention, the present boiler unit is substantially rectangular in shape and comprises a horizontally disposed base member 2F to which are secured vertically disposed front and back walls 15 and 16, and side walls 7 and 8. These wall members support a cover plate 33 which together with said walls encloses the water-containing space of the boiler. As best illustrated in Fig. 1, the side, back, and top walls of the water-containing space may be covered by a metal jacket 44, which is spaced from the boiler walls by means of insulation material 45, all in the usual fashion. An uninsulated cover door 39 is adapted to be removably secured over the front wall 15 for the purpose of enhancing the appearance of the boiler unit.

Mounted upon an extension 2a of the base member 2F is a usual type of oil burner unit 1 having a burner nozzle extending into the boiler unit through an aperture indicated at 50 and provided in a plate 3, covering the fire-box opening, which plate is suitably secured upon the front wall 15 of the boiler. This plate 3 is lined with fire brick, or other suitable heat-absorbing material 4. Disposed in front of the burner nozzle opening 50 and upon the base 2F by means of

legs 17, 18 is a baffle cover H having a bottom 9a, a rear wall 9b, side walls 9c, 9c, and an inclined top wall 9 constituting a baffle plate. The baffle cover H defines a fire-box space and, in conjunction with the front wall 15 of the boiler unit, effectively seals off the fire-box space from the water-containing portion of the boiler as the various wall portions of the cover H are welded, or otherwise suitably connected, to the boiler wall 15. Pins 19 and 20 maintain the rear wall 9b in spaced relation with the rear boiler wall 16.

Mounted directly within the confines of the baffle cover H is an open-topped fire box F which comprises a bottom wall 5, a rear wall 6, and a pair of side walls Fa and Fb. Legs 52, 52 space the fire box bottom 5 above the baffle base 9a, and the forward end portion of the fire box base and side walls butt directly against the fire brick 4.

Referring particularly to Figs. 1 and 2, it is to be understood that the oil burner unit 1 is effective to direct its flame horizontally into the fire box F and that a hinge plate 27 permits air to enter the fire box and thereby enhance combustion. Of course, this plate 27 will also permit a view of the interior of the fire box and, thus, enables one to ascertain whether proper combustion is being effected. The plate 27 is rotatably mounted upon a pin 28 which is carried by a bar 29 secured to the plate 3.

The baffle plate 9 of the housing H is effective to direct the products of combustion towards the front portion of the boiler unit and successively through flue sections 10, 11, and 12 and out through a stack connection 13 the back wall 16 of the boiler. The upper end portion of the baffle plate 9 is welded to a bottom portion of a header plate 10b which forms a back wall of a flue section 10 having a front wall 10d, side walls 10e, 10e, and a top wall 10a. As particularly shown in Fig. 2, the side walls 10e, 10e are each welded at its bottom portion to a respective one of the side walls 9c, 9c of the baffle cover 9 along the line 37, and the portions 10f and 10g of the top wall 10a and the front wall 10d of the flue section 10 are welded to the front boiler wall 15, thereby to prevent any water from seeping into the fire box.

Referring now to Figs. 5, 6, and 7, as well as to Fig. 2, it is to be understood that in the present invention the boiler flues comprise a series of horizontally spaced hollow elements 11a, 11b, 11c, 11d, and 11e. Each end portion of these flues extends through an appropriately shaped aperture provided in a respective one of a pair of horizontally spaced header plates 10b and 12c. By welding one end of each flue to its associated header, a rigid water-tight structure is formed and is best illustrated in Fig. 6. The header plate 12c is suitably joined to the stack connection 13 by means of a flue section 12 comprising top and bottom walls 12b and 12a, and side walls 12d, 12d. From this, it is to be understood that the combustion gases are conducted from the flue sections 10 to 12 by way of the individual flues 11a, 11b, 11c, 11d, 11e, and 11f, each of which is entirely surrounded by the boiler water, the normal level of which is designated by the line B of Fig. 2.

Referring particularly to Figs. 5, 6, and 7, it is to be understood that each of the individual flue sections comprises a pair of identical corrugated steel stampings which are placed together with their corrugations in phase and then welded along the line 53, 53 so as to form an open-ended flue having a tortuous gas-conducting passageway therein. Broadly, each flue section is shaped

as a flattened tube. Thereafter, each of the completed flue elements may be assembled to the header plates 10b and 12c, as hereinabove described. By thus forming each flue element in this manner, the two halves thereof may be inexpensively stamped from the same die and, furthermore, since the top and bottom edge portions, as well as the marginal portions of the open flue, are all left in an uncorrugated condition, the flue halves may be readily welded together and to the headers by automatic welding equipment. Also, since the flues provide tortuous gas-conducting passageways, there is no need to provide the various flues with auxiliary baffle plates. As the flues are corrugated substantially throughout their entire length, it is clear that they present an extremely large surface area to the boiler water and, thus, function as efficient heat transfer units.

Fig. 2 discloses the boiler unit provided with a pipe coil 22a located directly above the flue sections and having an external pipe connection 23 attached to a plate 24. This plate 24 is, in turn, removably secured over an aperture formed in the wall 16 of the boiler unit by means of studs 25 and nuts 26. The plate 24 is adapted to support the coil 22a and, thus, the coil may be readily removed from the boiler as a unit with the plate 24. Such coils function to heat water for various household uses.

Referring to Figs. 3 and 4, there is disclosed a modified form of hot water coil 22 which comprises two tiers of pipes 22d and 22b, and has inlet and outlet connections 23 and 23a respectively, each being carried by the plate 24.

Fresh water may be supplied to the present boiler unit through a water inlet connection W formed in the lower portion of the boiler wall 16. The top wall 33 of the boiler is provided with a steam connection aperture 31 and a connection aperture 32 to which a usual type of safety valve may be attached. A wet-return pipe may be connected to the boiler by means of a connection aperture 30 formed in the boiler wall 16. Corresponding to the openings 31 and 32 in the boiler wall 33 are apertures 31a and 32a formed in the cabinet cover or housing C which is spaced from the boiler wall 33 by means of legs 34 and 35. Formed in the top forward portion of the housing C are a series of slots 36, 36 which permit air to enter the space between the housing door 39 and the front boiler wall 15 for the purpose of supplying the oil burner with the requisite amount of oxygen for efficient combustion. As illustrated in Fig. 1, various conventional instruments for indicating or controlling the operation of the boiler may be mounted upon the boiler wall 15, as at 40, 41, 42, and 43. Such instruments usually take the form of pressure gages, thermostats, aquastats, etc.

From the above description, it is to be understood that water is fed to the boiler through the inlet W and rises to level B and thus surrounds the major portion of the baffle cover H, as well as the various flue sections 10, 11, and 12. Due to this condition, and the fact that each of the individual flue sections is corrugated, as hereinabove described, the present boiler unit presents an extremely large heat transfer surface area to the boiler water with a result that a high degree of boiler efficiency results.

Having thus described my invention, what I claim as new and desire to secure by Letters Patent, is:

1. In a boiler unit having a base, a boiler

5

mounted upon said base, a fire box disposed within said boiler and said base, a stack connection disposed at one side of said boiler above said fire box, and a flue section disposed within said boiler in spaced relation with said stack connection and having an opening for the reception of gases from said fire box; the improvement which consists in the provision of a plurality of horizontally spaced gas-conducting flue elements connecting said flue section with said stack connection, each of said flue elements comprising a pair of similar plates each having a pair of oppositely disposed edge portions thereof curved away from one side of the plate and welded to the similarly curved edge portions of its associated plate thereby to form a conduit having the shape of a flattened tube, and the opposing two sides of said tube being corrugated in phase and transversely of the tube length thereby providing a tortuous gas-conducting passageway therethrough.

2. In a boiler unit having a base, a boiler mounted upon said base, a firebox disposed within said boiler and upon said base, a stack connection disposed at one side of said boiler above said firebox, a first hollow flue section connected with said stack connection and disposed directly within said boiler above said firebox, and a second hollow flue section disposed directly within said boiler and having an opening for the reception of gases from said firebox; the improvement which consists in the provision of a third flue section unit for connecting said first and second flue sections, said third flue section comprising, a pair of spaced header plates with correspondingly disposed elongated slots therein, and a plurality of individual gas-conducting flue elements disposed between and connected to said header plates, each of said flue elements having the general shape of a flattened open ended tube with the two opposing side walls thereof being corrugated transversely of the tube length thereby providing a tortuous gas-conducting passageway therethrough, each of said tubes having each of its open end portions disposed within one of the elongated slots of a respective one of said two header plates, said third flue section having each of its header plates secured directly to a respective one of said first and second flue sections so as to conduct the hot gases from said firebox to said stack connection.

3. In a boiler unit having a base, a boiler mounted upon said base, a firebox disposed within said boiler and upon said base, a stack connection disposed at one side of said boiler above said firebox, a first hollow flue section connected with said stack connection and disposed directly within said boiler above said firebox, and a second hollow flue section disposed directly within said boiler and having an opening for the reception of gases from said firebox; the improvement which consists in the provision of a third flue section unit for connecting said first and second flue sections, said third flue section comprising, a pair of spaced parallel header plates with correspondingly disposed elongated slots therein, and a plurality of individual gas-conducting flue elements disposed between and connected to said header plates, each of said flue elements being horizontally spaced from the others and disposed between and connected to said header plates, each of said flue elements having the general shape of a flattened tube with two vertically disposed and opposing side walls thereof being corrugated in phase and transversely of the tube length thereby producing a tortuous open ended gas-

6

conducting passageway therethrough, each of said tubes having each of its open end portions disposed within one of the elongated slots of a respective one of said two header plates, said third flue section having each of its header plates secured directly to a respective one of said first and second flue sections so as to conduct the hot gases from said firebox to said stack connection.

4. A heating apparatus comprising, a boiler including a vertically disposed shell, top and bottom closure plates and having a combustion chamber and a combined water and steam chamber formed respectively within the bottom and upper portions thereof, said shell having a firebox opening therein communicating with said combustion chamber, said combustion chamber being defined by a vertically disposed open ended shell secured upon said bottom closure plate and spaced from said boiler shell so as to be almost entirely surrounded by water, the open ends of said combustion chamber shell being secured to said boiler shell at either side of said firebox opening, and cover means secured over said combustion chamber shell so as to seal the combustion chamber from the water and steam chamber, a vertically disposed open topped and open ended firebox shell mounted upon said bottom closure plate within said combustion chamber with the open ends thereof secured to said boiler shell at either side of said firebox opening, a first hollow gas-collecting flue section connected directly with the upper portion of said combustion chamber for receiving the gases therefrom, said first flue section being disposed within said water and steam chamber so as to be surrounded by the boiler water, a stack connection projecting from the upper portion of said boiler shell, a second hollow flue section disposed within said water and steam chamber and being connected with said stack connection, and a plurality of individual gas-conducting flue elements connecting said first and second flue sections so as to conduct the gases from said combustion chamber to said stack connection, each of said flue elements being horizontally spaced from each other and having the general shape of a flattened tube with the two opposing vertical side walls thereof being corrugated transversely of the tube length thereby providing a tortuous gas-conducting passageway therethrough.

5. A heating apparatus comprising, a boiler including a vertically disposed shell, top and bottom closure plates and having a combustion chamber and a combined water and steam chamber formed respectively within the bottom and upper portions thereof, said shell having a firebox opening therein communicating with said combustion chamber, said combustion chamber being defined by a vertically disposed open ended shell secured upon said bottom closure plate and spaced from said boiler shell so as to be almost entirely surrounded by water, the open ends of said combustion chamber shell being secured to said boiler shell at either side of said firebox opening, and cover means secured over said combustion chamber shell so as to seal the combustion chamber from the water and steam chamber, a vertically disposed open topped and open ended firebox shell mounted upon said bottom closure plate within said combustion chamber with the open ends thereof secured to said boiler shell at either side of said firebox opening, a stack connection projecting from the upper portion of said boiler shell, and

7

a flue section disposed entirely within the water and steam chamber for connecting said stack connection with said combustion chamber, said flue section including a pair of parallel and spaced flat header plates with correspondingly disposed elongated slots therein, and a plurality of individual gas-conducting flue elements disposed between and connected to said header plates, each of said flue elements having the general shape of a flattened open ended tube with the two opposing side walls thereof being corrugated transversely of the tube length thereby providing a tortuous gas-conducting passage-way therethrough, each of said tubes having each of its open end portions disposed within one of the elongated slots of a respective one of said two header plates, said flue section unit having each of its header plates connected respectively to said combustion chamber and said stack connection so as to place said flue elements in communication with said latter units.

HOTHER H. ANDERSEN.

8

REFERENCES CITED

The following references are of record in the file of this patent:

UNITED STATES PATENTS

Number	Name	Date
1,307,433	Beuckman et al.	June 24, 1919
1,681,726	Du Brie	Aug. 21, 1928
2,099,383	Anderson	Nov. 16, 1937
2,135,235	Hurford et al.	Nov. 1, 1938
2,186,803	Goerg	Jan. 9, 1940
2,189,135	Dickson	Feb. 6, 1940
2,210,830	Bernhard	Aug. 6, 1940
2,231,652	Baer	Feb. 11, 1941

FOREIGN PATENTS

Number	Country	Date
25,502	Germany	Feb. 13, 1884