



(51) International Patent Classification:

A61F 2/78 (2006.01) A61F 2/24 (2006.01)
A61F 2/76 (2006.01) A61M 39/22 (2006.01)

(21) International Application Number:

PCT/US2012/043761

(22) International Filing Date:

22 June 2012 (22.06.2012)

(25) Filing Language:

English

(26) Publication Language:

English

(30) Priority Data:

61/501,404 27 June 2011 (27.06.2011) US
61/550,772 24 October 2011 (24.10.2011) US

(71) Applicant (for all designated States except US): **UNIVERSITY OF MARYLAND, BALTIMORE** [US/US]; 620 W. Lexington Street, Fourth Floor, Baltimore, Maryland 21201 (US).

(72) Inventors; and

(75) Inventors/Applicants (for US only): **GAMMIE, James** [US/US]; 2207 Wiltonwood Road, Stevenson, Maryland 21153 (US). **PATEL, Rahul** [US/US]; 1263 Haubert Street, Baltimore, Maryland 21230 (US). **GHOREISHI, Mehrdad** [IR/US]; 511 W. Pratt Street, Apt. 1603, Baltimore, Maryland 21201 (US).

(74) Agents: **MAYNARD, Jeffrey C.** et al.; Gibb & Riley, LLC, 844 West Street, Suite 100, Annapolis, Maryland 21401 (US).

(81) Designated States (unless otherwise indicated, for every kind of national protection available): AE, AG, AL, AM, AO, AT, AU, AZ, BA, BB, BG, BH, BR, BW, BY, BZ, CA, CH, CL, CN, CO, CR, CU, CZ, DE, DK, DM, DO, DZ, EC, EE, EG, ES, FI, GB, GD, GE, GH, GM, GT, HN, HR, HU, ID, IL, IN, IS, JP, KE, KG, KM, KN, KP, KR, KZ, LA, LC, LK, LR, LS, LT, LU, LY, MA, MD, ME, MG, MK, MN, MW, MX, MY, MZ, NA, NG, NI, NO, NZ, OM, PE, PG, PH, PL, PT, QA, RO, RS, RU, RW, SC, SD, SE, SG, SK, SL, SM, ST, SV, SY, TH, TJ, TM, TN, TR, TT, TZ, UA, UG, US, UZ, VC, VN, ZA, ZM, ZW.

(84) Designated States (unless otherwise indicated, for every kind of regional protection available): ARIPO (BW, GH, GM, KE, LR, LS, MW, MZ, NA, RW, SD, SL, SZ, TZ, UG, ZM, ZW), Eurasian (AM, AZ, BY, KG, KZ, RU, TJ, TM), European (AL, AT, BE, BG, CH, CY, CZ, DE, DK, EE, ES, FI, FR, GB, GR, HR, HU, IE, IS, IT, LT, LU, LV, MC, MK, MT, NL, NO, PL, PT, RO, RS, SE, SI, SK, SM, TR), OAPI (BF, BJ, CF, CG, CI, CM, GA, GN, GQ, GW, ML, MR, NE, SN, TD, TG).

Published:

— with international search report (Art. 21(3))

[Continued on next page]

(54) Title: TRANSAPICAL MITRAL VALVE REPAIR DEVICE

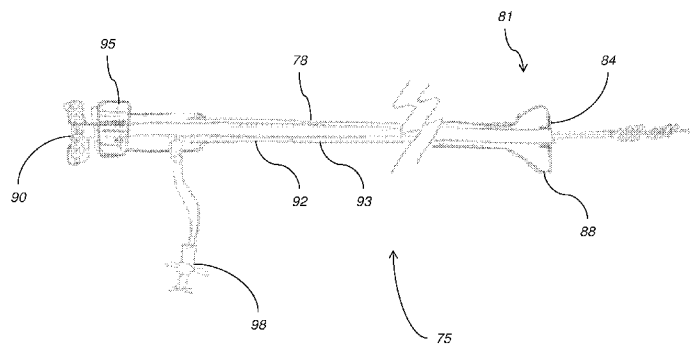
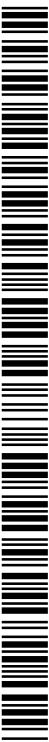

FIG. 7

(57) Abstract: Methods and devices for repairing a cardiac valve. A minimally invasive procedure includes creating an access in the apex region of the heart through which one or more instruments may be inserted. The device can implant artificial heart valve chordae tendineae into cardiac valve leaflet tissues to restore proper leaflet function and prevent reperfusion. The device punctures the apex of the heart and travels through the ventricle. The tip of the device rests on the defective valve and punctures the valve leaflet. A suture or a suture/guide wire combination is inserted, securing the top of the leaflet to the apex of the heart. A resilient element or shock absorber mechanism adjacent to the outside of the apex of the heart minimizes the linear travel of the device in response to the beating of the heart or opening/closing of the valve.



- *before the expiration of the time limit for amending the claims and to be republished in the event of receipt of amendments (Rule 48.2(h))*

Transapical Mitral Valve Repair Device

BACKGROUND

FIELD OF THE DISCLOSURE

The disclosure herein relates to methods and devices for performing cardiac valve repairs, and more particularly, the disclosure relates to methods and devices for performing
5 minimally invasive mitral or tricuspid valve repairs using of PTFE neochords through a minimally invasive incision, while the heart is beating.

DESCRIPTION OF THE BACKGROUND

As illustrated in Figure 1, the human heart 10 has four chambers, which include two
10 upper chambers denoted as atria 12, 16 and two lower chambers denoted as ventricles 14, 18. A septum 20 divides the heart 10 and separates the left atrium 12 and left ventricle 14 from the right atrium 16 and right ventricle 18. The heart further contains four valves 22, 24, 26, and 28. The valves function to maintain the pressure and unidirectional flow of blood through the body and to prevent blood from leaking back into a chamber from which it has
15 been pumped.

Two valves separate the atria 12, 16 from the ventricles 14, 18, denoted as atrioventricular valves. The left atrioventricular valve, the mitral valve 22, controls the passage of oxygenated blood from the left atrium 12 to the left ventricle 14. A second valve, the aortic valve 24, separates the left ventricle 14 from the aortic artery (aorta) 30, which
20 delivers oxygenated blood via the circulation to the entire body. The aortic valve 24 and mitral valve 22 are part of the "left" heart, which controls the flow of oxygen-rich blood from the lungs to the body. The right atrioventricular valve, the tricuspid valve 26, controls passage of deoxygenated blood into the right ventricle 18. A fourth valve, the pulmonary valve 28, separates the right ventricle 18 from the pulmonary artery 32. The right ventricle
25 18 pumps deoxygenated blood through the pulmonary artery 32 to the lungs wherein the blood is oxygenated and then delivered to the left atrium 12 via the pulmonary vein. Accordingly, the tricuspid valve 26 and pulmonic valve 28 are part of the "right" heart, which control the flow of oxygen-depleted blood from the body to the lungs.

Both the left and right ventricles 14, 18 constitute "pumping" chambers. The aortic
30 valve 24 and pulmonic valve 28 lie between a pumping chamber (ventricle) and a major artery and control the flow of blood out of the ventricles and into the circulation. The aortic valve 24 and pulmonic valve 28 have three cusps, or leaflets, that open and close and thereby function to prevent blood from leaking back into the ventricles after being ejected into the lungs or aorta 30 for circulation.

Both the left and right atria 12, 16 are "receiving" chambers. The mitral valve 22 and tricuspid valve 26, therefore, lie between a receiving chamber (atrium) and a ventricle so as to control the flow of blood from the atria to the ventricles and prevent blood from leaking back into the atrium during ejection into the ventricle. Both the mitral valve 22 and tricuspid valve 26 include two or more cusps, or leaflets (shown in Figure 2), that are encircled by a variably dense fibrous ring of tissues known as the annulus. The valves are anchored to the walls of the ventricles by chordae tendineae (chordae) 42. The chordae tendineae 42 are cord-like tendons that connect the papillary muscles 44 to the leaflets (not shown) of the mitral valve 22 and tricuspid valve 26 of the heart 10. The papillary muscles 44 are located at the base of the chordae 42 and are within the walls of the ventricles. They serve to limit the movements of the mitral valve 22 and tricuspid valve 26 and prevent them from being reverted. The papillary muscles 44 do not open or close the valves of the heart, which close passively in response to pressure gradients; rather, the papillary muscles 44 brace the valves against the high pressure needed to circulate the blood throughout the body. Together, the papillary muscles 44 and the chordae tendineae 42 are known as the subvalvular apparatus. The function of the subvalvular apparatus is to keep the valves from prolapsing into the atria when they close.

As illustrated with reference to Figure 2, the mitral valve 22 includes two leaflets, the anterior leaflet 52 and the posterior leaflet 54, and a diaphanous incomplete ring around the valve, called the annulus 60. The mitral valve 22 has two papillary muscles 44, the anteromedial and the posterolateral papillary muscles, which attach the leaflets 52, 54 to the walls of the left ventricle 14 via the chordae tendineae 42. The tricuspid valve 26 typically is made up of three leaflets with three papillary muscles. However, the number of leaflets can range between two and four. The three leaflets of the tricuspid valve 26 are referred to as the anterior, posterior, and septal leaflets. Although both the aortic and pulmonary valves each have three leaflets (or cusps), they do not have chordae tendineae.

Various disease processes can impair the proper functioning of one or more of the valves of the heart. These disease processes include degenerative processes (e.g., Barlow's Disease, fibroelastic deficiency), inflammatory processes (e.g., Rheumatic Heart Disease), and infectious processes (e.g., endocarditis). Additionally, damage to the ventricle from prior heart attacks (i.e., myocardial infarction secondary to coronary artery disease) or other heart diseases (e.g., cardiomyopathy) can distort the valve's geometry causing it to dysfunction. However, the vast majority of patients undergoing valve surgery, such as mitral valve

surgery, suffer from a degenerative disease that causes a malfunction in a leaflet of the valve, which results in prolapse and regurgitation.

Generally, a heart valve may malfunction two different ways. One possible malfunction, valve stenosis, occurs when a valve does not open completely and thereby causes an obstruction of blood flow. Typically, stenosis results from buildup of calcified material on the leaflets of the valves causing them to thicken and thereby impairing their ability to fully open and permit adequate forward blood flow.

Another possible malfunction, valve regurgitation, occurs when the leaflets of the valve do not close completely thereby causing blood to leak back into the prior chamber. There are three mechanisms by which a valve becomes regurgitant or incompetent; they include Carpentier's type I, type II and type III malfunctions. A Carpentier type I malfunction involves the dilation of the annulus such that normally functioning leaflets are distracted from each other and fail to form a tight seal (i.e., do not coapt properly). Included in a type I mechanism malfunction are perforations of the valve leaflets, as in endocarditis. A Carpentier's type II malfunction involves prolapse of one or both leaflets above the plane of coaptation. This is the most common cause of mitral regurgitation, and is often caused by the stretching or rupturing of chordae tendineae normally connected to the leaflet. A Carpentier's type III malfunction involves restriction of the motion of one or more leaflets such that the leaflets are abnormally constrained below the level of the plane of the annulus. Leaflet restriction can be caused by rheumatic disease (IIIa) or dilation of the ventricle (IIIb).

Figure 3 illustrates a prolapsed mitral valve 22. As can be seen with reference to Figure 3, prolapse occurs when a leaflet 52, 54 of the mitral valve 22 is displaced into the left atrium 12 during systole. Because one or more of the leaflets 52, 54 malfunction, the mitral valve 22 does not close properly, and, therefore, the leaflets fail to coapt. This failure to coapt causes a gap 63 between the leaflets 52, 54 that allows blood to flow back into the left atrium 12, during systole, while it is being ejected into the left ventricle 14. As set forth above, there are several different ways a leaflet may malfunction, which can thereby lead to regurgitation.

Although stenosis or regurgitation can affect any valve, stenosis is predominantly found to affect either the aortic valve 24 or the pulmonic valve 28, whereas regurgitation predominately affects either the mitral valve 22 or the tricuspid valve 26. Both valve stenosis and valve regurgitation increase the workload on the heart 10 and may lead to very serious conditions if left un-treated; such as endocarditis, congestive heart failure, permanent heart damage, cardiac arrest, and ultimately death. Since the left heart is primarily responsible for

circulating the flow of blood throughout the body, malfunction of the mitral valve 22 or tricuspid valve 26 is particularly problematic and often life threatening. Accordingly, because of the substantially higher pressures on the left side of the heart, left-sided valve dysfunction is much more problematic.

5 Malfunctioning valves may either be repaired or replaced. Repair typically involves the preservation and correction of the patient's own valve. Replacement typically involves replacing the patient's malfunctioning valve with a biological or mechanical substitute. Typically, the aortic valve 24 and pulmonic valve 28 are more prone to stenosis. Because stenotic damage sustained by the leaflets is irreversible, the most conventional treatment for
10 stenotic aortic and pulmonic valves is removal and replacement of the diseased valve. The mitral valve 22 and tricuspid valve 26, on the other hand, are more prone to deformation. Deformation of the leaflets, as described above, prevents the valves from closing properly and allows for regurgitation or back flow from the ventricle into the atrium, which results in valvular insufficiency. Deformations in the structure or shape of the mitral valve 22 or
15 tricuspid valve 26 are often repairable.

Valve repair is preferable to valve replacement. Bioprosthetic valves have limited durability. Moreover, prosthetic valves rarely function as well as the patient's own valves. Additionally, there is an increased rate of survival and a decreased mortality rate and incidence of endocarditis for repair procedures. Further, because of the risk of
20 thromboembolism, mechanical valves often require further maintenance, such as the lifelong treatment with blood thinners and anticoagulants. Therefore, an improperly functioning mitral valve 22 or tricuspid valve 26 is ideally repaired, rather than replaced. However, because of the complex and technical demands of the repair procedures, the overall repair rate in the United States is only around 50%.

25 Conventional techniques for repairing a cardiac valve are labor-intensive, technically challenging, and require a great deal of hand-to-eye coordination. They are, therefore, very challenging to perform, and require a great deal of experience and extremely good judgment. For instance, the procedures for repairing regurgitating leaflets may require resection of the prolapsed segment and insertion of an annulasty ring so as to reform the annulus of the
30 valve. Additionally, leaflet sparing procedures for correcting regurgitation are just as labor-intensive and technically challenging, if not requiring an even greater level of hand-to-eye coordination. These procedures involve the implantation of sutures (e.g., ePTFE or GORE-TEX™ sutures) so as to form artificial chordae in the valve. In these procedures, rather than performing a resection of the leaflets and/or implanting an annulasty ring into the patient's

valve, the prolapsed segment of the leaflet is re-suspended using artificial chord sutures. Oftentimes, leaflet resection, annuloplasty, and neochord implantation procedures are performed in conjunction with one another.

5 Regardless of whether a replacement or repair procedure is being performed, conventional approaches for replacing or repairing cardiac valves are typically invasive open-heart surgical procedures, such as sternotomy or thoracotomy, that require opening up of the thoracic cavity so as to gain access to the heart. Once the chest has been opened, the heart is bypassed and stopped. Cardiopulmonary bypass is typically established by inserting
10 cannulae into the superior and inferior vena cavae (for venous drainage) and the ascending aorta (for arterial perfusion), and connecting the cannulae to a heart-lung machine, which functions to oxygenate the venous blood and pump it into the arterial circulation, thereby bypassing the heart. Once cardiopulmonary bypass has been achieved, cardiac standstill is established by clamping the aorta and delivering a "cardioplegia" solution into the aortic root and then into the coronary circulation, which stops the heart from beating. Once cardiac
15 standstill has been achieved, the surgical procedure may be performed. These procedures, however, adversely affect almost all of the organ systems of the body and may lead to complications, such as strokes, myocardial "stunning" or damage, respiratory failure, kidney failure, bleeding, generalized inflammation, and death. The risk of these complications is directly related to the amount of time the heart is stopped ("cross-clamp time") and the
20 amount of time the subject is on the heart-lung machine ("pump time").

Furthermore, the conventional methods currently being practiced for the implantation of the artificial chordae are particularly problematic. Because the conventional approach requires the heart to be stopped (e.g., via atriotomy) it is difficult to accurately determine, assess, and secure the appropriate chordal length. Since the valve will not function properly
25 if the length of the artificial chordae is too long or too short, the very problem sought to be eradicated by the chordal replacement procedure may, in fact, be exacerbated. Using conventional techniques, it is very difficult to ensure that the chordae are of the correct length and are appropriately spaced inside the ventricle to produce a competent valve.

30 There is a significant need to perform mitral valve repairs using less invasive procedures while the heart is still beating. Accordingly, there is a continuing need for new procedures and devices for performing cardiac valve repairs, such as mitral and tricuspid valve repairs, which are less invasive, do not require cardiac arrest, and are less labor-intensive and technically challenging. Chordal replacement procedures and artificial chordae

that ensure the appropriate chordal length and spacing so as to produce a competent valve are of particular interest. The methods and repair devices presented herein meet these needs.

SUMMARY

5 It is an object of the disclosure to provide a method and device to enable minimally invasive, beating-heart, mitral valve repair.

It is another object of the disclosure to provide an expansile element that can be inserted through a mitral valve leaflet, and which can be deployed above the valve leaflet in order to secure it in place.

10 It is another object of the disclosure to enable chordal replacement with ePTFE. A related object of the present disclosure is to provide a chordal replacement that facilitates mitral valve repair.

Another object of the disclosure is to provide a method and device for transapical mitral valve repair that uses a small incision. A related object of the disclosure is to provide a method that does not require a Sternotomy. Another related object of the disclosure is to provide a method that does not require cardiopulmonary bypass or aortic manipulation.

Another object of the disclosure is to provide a method and device for transapical mitral valve repair that uses real-time, echo-guided, chordal length adjustment.

20 A basic concept of the method of the disclosure herein is to insert a tool via the apex of the heart, grasp or pierce the defective heart valve leaflet, deploy a PTFE neochord, and adjust the length of the chord under echo guidance to resolve the mitral valve regurgitation.

These and other objects of the present disclosure are accomplished by providing a device for minimally invasive repair of a defective heart valve while the heart is beating. The heart can be accessed through the apex or a point lateral/near to the apex with a small-diameter shafted instrument. The instrument might be a needle or a catheter. Using 25 ultrasound guidance (real-time transesophageal echocardiography), the shafted instrument is inserted through an access port at the apex (or near the apex) and the instrument is guided to make contact with the mitral valve leaflet at the location where the operator has decided that a neochord should be inserted. Typically, this would be the body of the anterior or posterior leaflet in a location where the valve has prolapsed as a result of a broken or elongated chord. 30 The instrument punctures the apex of the heart and travels through the ventricle. The tip of the instrument rests on the defective valve and punctures the valve leaflet. The instrument then inserts either a suture or a suture/guide wire combination, securing the top of the leaflet to the apex of the heart with an artificial chordae. A resilient element or shock absorber

mechanism adjacent to the outside of the apex of the heart minimizes the linear travel of the instrument in response to the beating of the heart or opening/closing of the valve.

In a first embodiment, the instrument punctures the defective leaflet twice. A first needle deploys a loop wire with the loop encircling the area immediately above a second
5 needle. The second needle deploys a suture through the loop deployed by the first needle. After the loop ensnares the suture, the loop and suture are retracted into the first needle. The instrument is pulled out of the heart while the suture remains through the leaflet. The length of the suture is adjusted and the ends of the suture are then affixed to the outer surface of the heart near the apex of the heart. Typically, the suture would be secured to a pledget.

10 According to another embodiment, once the instrument is in contact with the mitral valve leaflet in the targeted location, a "PTFE-wrapped needle" is advanced rapidly across the leaflet and subsequently rapidly withdrawn. After the PTFE-wrapped needle is advanced across the leaflet, the core is withdrawn and a pusher needle/sheath remains across the needle. Withdrawal pressure is applied to the two ends of the PTFE suture at the base of the needle
15 (outside of the heart). This withdrawal pressure results in the development of a pre-formed knot that attains a significant size in the atrium, above the leaflet. The pusher needle is then withdrawn with the delivery instrument, and the length of the PTFE sutures are adjusted so that the amount of mitral regurgitation is minimized. Once this length is determined, the PTFE is secured to the outer surface of the heart using a pledget.

20 In another embodiment, a single needle punctures the defective leaflet and deploys a coated, coiled guide wire having a suture woven through it. The suture is then pulled, causing the guide wire to configure into a predetermined shape above the leaflet. The instrument is then retracted out of the heart and the length of the guide wire/suture is adjusted. Once this length is determined, the guide wire/suture is affixed near the apex of the
25 heart.

BRIEF DESCRIPTION OF THE DRAWINGS

The above and other features, aspects, and advantages of the present disclosure are considered in more detail, in relation to the following description of embodiments thereof shown in the accompanying drawings, in which:

30 FIG. 1 is a cut-away anterior view of the human heart showing the internal chambers, valves, and adjacent structures.

FIG. 2 is a perspective view of a healthy mitral valve with the leaflets closed.

FIG. 3 is a top view of a dysfunctional mitral valve with a visible gap between the leaflets.

FIG. 4 shows a simplified view of a heart with four chambers and apex region.

FIG. 5 illustrates the advancement of a device through an accessed region of the heart in accordance with the methods of embodiments herein.

FIGS. 6a - 6c illustrate an exemplary device according to embodiments herein.

5 FIG. 7 illustrates an exemplary device according to embodiments herein.

FIGS. 8a - 8f show exemplary stages of the tip portion of an instrument according to an embodiment herein.

FIGS. 9a – 9d show an exemplary instrument according to another embodiment herein.

10 FIGS. 10a – 10e illustrate an additional embodiment herein.

FIG. 11 shows an exemplary instrument according to an embodiment herein.

FIGS. 12a – 12g show an exemplary instrument according to another embodiment herein.

15 FIGS. 13a – 13c illustrates formation of a bulk knot in accordance with an embodiment herein.

FIGS. 14a – 14c show an additional embodiment herein.

FIG. 15 illustrates an installed chord in accordance with an embodiment herein.

FIG. 16 illustrates an expansile element according to another embodiment herein.

20 FIG. 17 is another illustration of an expansile element according to embodiments herein.

FIG. 18 illustrates use of a single needle device in accordance with the methods of embodiments herein.

FIG. 19 illustrates use of an alternate single needle device in accordance with the methods of embodiments herein.

25 FIG. 20 shows an additional embodiment herein.

FIG. 21 illustrates locking steps in accordance with the methods of embodiments herein.

FIG. 22 illustrates use of the device of embodiments herein in accordance with another method.

30 DETAILED DESCRIPTION OF EXEMPLARY EMBODIMENTS

In accordance with the methods of embodiments herein, the heart may be accessed through one or more openings made by a small incision(s) in a portion of the body proximal to the thoracic cavity, for instance, in between one or more of the ribs of the rib cage, proximate to the xyphoid appendage, or via the abdomen and diaphragm. Access to the

thoracic cavity may be sought so as to allow the insertion and use of one or more thorascopic instruments, while access to the abdomen may be sought so as to allow the insertion and use of one or more laparoscopic instruments. Insertion of one or more visualizing instruments may then be followed by transdiaphragmatic access to the heart. Additionally, access to the heart may be gained by direct puncture (i.e., via an appropriately sized needle, for instance an 18 gauge needle) of the heart from the xyphoid region. Access may also be achieved using percutaneous means. Accordingly, the one or more incisions should be made in such a manner as to provide an appropriate surgical field and access site to the heart. See for instance, Full-Spectrum Cardiac Surgery Through a Minimal Incision Mini-Stemotomy (Lower Half) Technique Doty et al. *Annals of Thoracic Surgery* 1998; 65(2): 573-7 and Transxyphoid Approach Without Median Stemotomy for the Repair of Atrial Septal Defects, Barbero-Marcial et al. *Annals of Thoracic Surgery* 1998; 65(3): 771-4 which are specifically incorporated in their entirety herein by reference.

After prepping and placing the subject under anesthesia a transesophageal echocardiogram (TEE) (2D or 3D), a transthoracic echocardiogram (TTE), intracardiac echo (ICE), or cardio-optic direct visualization (e.g., via infrared vision from the tip of a 7.5 F catheter) may be performed to assess the heart and its valves. A careful assessment of the location and type of dysfunction on the TEE, TTE, or other such instrument, facilitates the planning of the appropriate surgical procedure to be performed. The use of TEE, TTE, ICE, or the like, can assist in determining if there is a need for adjunctive procedures to be performed on the leaflets and subvalvular apparatus and can indicate whether a minimally invasive approach is advisable.

Once a minimally invasive approach is determined to be advisable, one or more incisions are made proximate to the thoracic cavity so as to provide a surgical field of access. The total number and length of the incisions to be made depend on the number and types of the instruments to be used as well as the procedure(s) to be performed. The incision(s) should be made in such a manner so as to be minimally invasive. By "minimally invasive" is meant in a manner by which an interior organ or tissue may be accessed with as little as possible damage being done to the anatomical structure through which entry is sought. Typically, a minimally invasive procedure is one that involves accessing a body cavity by a small incision made in the skin of the body. By "small incision" is meant that the length of the incision generally should be about 1 cm to about 10 cm, or about 4 cm to about 8 cm, or about 7 cm in length. The incision may be vertical, horizontal, or slightly curved. If the incision is placed along one or more ribs, it should follow the outline of the rib. The opening

should extend deep enough to allow access to the thoracic cavity between the ribs or under the sternum and is preferably set close to the rib cage and/or diaphragm, dependent on the entry point chosen.

One or more other incisions may be made proximate to the thoracic cavity to accommodate insertion of a surgical scope. Such an incision is typically about 1 cm to about 10 cm, or about 3 cm to 7 cm, or about 5 cm in length and should be placed near the pericardium so as to allow ready access to and visualization of the heart. The surgical scope may be any type of endoscope, but is typically a thoracoscope or laparoscope, dependent upon the type of access and scope to be used. The scope generally has a flexible housing and at least a 16-times magnification. Insertion of the scope through an incision allows a practitioner to analyze and "inventory" the thoracic cavity and the heart so as to determine further the clinical status of the subject and plan the procedure. For example, a visual inspection of the thoracic cavity may reveal important functional and physical characteristics of the heart, and will indicate the access space (and volume) required at the surgical site and in the surgical field in order to perform the reparative cardiac valve procedure. At this point, the practitioner can confirm that access of one or more cardiac valves through the apex of the heart is appropriate for the particular procedure to be performed.

With reference to Figure 4, once a suitable entry point has been established, a suitable device such as one described herein, may be advanced into the body in a manner so as to make contact with the heart 10. The advancement of the device may be performed in conjunction with sonography or direct visualization (e.g., direct transblood visualization). For instance, the device may be advanced in conjunction with TEE guidance or ICE so as to facilitate and direct the movement and proper positioning of the device for contacting the appropriate apical region of the heart. Typical procedures for use of echo guidance are set forth in Suematsu, Y., J. Thorac. Cardiovasc. Surg. 2005; 130:1348-1356, herein incorporated by reference in its entirety.

One or more chambers 12, 14, 16, 18 in the heart 10 may be accessed in accordance with the methods disclosed herein. Access into a chamber in the heart may be made at any suitable site of entry but is preferably made in the apex region of the heart (e.g., at or adjacent to the apex 72). Typically, access into the left ventricle 14, for instance, to perform a mitral valve repair, is gained through making a small incision into the apical region, close to (or slightly skewed toward the left of) the median axis 74 of the heart 10. Typically, access into the right ventricle 18, for instance, to perform a tricuspid valve repair, is gained through making a small incision into the apical region, close to or slightly skewed toward the right of

the median axis 74 of the heart 10. Generally, an apex region of the heart is a bottom region of the heart that is within the left or right ventricular region but is distal to the mitral valve 22 and tricuspid valve 26 and toward the tip or apex 72 of the heart 10. More specifically, an "apex region" of the heart is within a few centimeters to the right or to the left of the septum 20 of the heart 10. Accordingly, the ventricle can be accessed directly via the apex 72, or via an off apex location that is in the apical region, but slightly removed from the apex 72, such as via a lateral ventricular wall, a region between the apex and the base of a papillary muscle, or even directly at the base of a papillary muscle. Typically, the incision made to access the appropriate ventricle of the heart is no longer than about 1 mm to about 5 cm, from 2.5 mm to about 2.5 cm, from about 5 mm to about 1 cm in length.

As explained above, both the mitral valve 22 and tricuspid valve 26 can be divided into three parts - an annulus, leaflets, and a sub-valvular apparatus. If the valve is functioning properly, when closed, the free margins of the leaflets come together and form a tight junction the arc of which, in the mitral valve, is known as the line of coaptation. The normal mitral and tricuspid valves open when the ventricles relax allowing blood from the left atrium to fill the decompressed ventricle. When the ventricle contracts, the increase in pressure within the ventricle causes the valve to close, thereby preventing blood from leaking into the atrium and assuring that all of the blood leaving the ventricle is ejected through the aortic valve 24 and pulmonic valve 28 into the arteries of the body. Accordingly, proper function of the valves depends on a complex interplay between the annulus, leaflets, and subvalvular apparatus. Lesions in any of these components can cause the valve to dysfunction and thereby lead to valve regurgitation. As set forth above, regurgitation occurs when the leaflets do not coapt at peak contraction pressures. As a result, an undesired back flow of blood from the ventricle into the atrium occurs.

Once the malfunctioning cardiac valve has been assessed and the source of the malfunction verified, a corrective procedure can be performed. Various procedures can be performed in accordance with the methods of the disclosure herein in order to effectuate a cardiac valve repair, which will depend on the specific abnormality and the tissues involved.

In one embodiment, a method of the present disclosure includes the implantation of one or more artificial chordae tendineae into one or more leaflets of a malfunctioning mitral valve 22 and/or tricuspid valve 26. It is to be noted that, although the following procedures are described with reference to repairing a cardiac mitral or tricuspid valve by the implantation of one or more artificial chordae, the methods herein presented are readily adaptable for various types of leaflet repair procedures well-known and practiced in the art,

for instance, an Alfieri procedure. In general, the methods herein will be described with reference to a mitral valve 22.

As illustrated in Figure 5, in accordance with the methods of the present disclosure, once an appropriate incision has been made in the apex region of the heart, for instance, in the apex 72, a suitable instrument 75 is then introduced into the ventricle 14 of the heart and advanced in such a manner so as to contact one or more cardiac tissues (for instance, a leaflet, an annulus, a cord, a papillary muscle, or the like) that are in need of repair. Sonic guidance, for instance, TEE guidance or ICE, may be used to assist in the advancement of the device into the ventricle and the grasping of the cardiac tissue with the device. Direct trans-blood visualization may also be used.

A suitable instrument 75, such as the one presented in Figures 5, 6a – 6c, and 7, will typically include an elongate member 78 with a functional distal portion 81 having a tip 84 configured for repairing a cardiac valve tissue, for instance, a mitral valve leaflet 52, 54. The functional distal portion 81 of the device is configured for performing one or more selected functions, such as grasping, suctioning, irrigating, cutting, suturing, or otherwise engaging a cardiac tissue. Using a manipulatable handle portion 87, the instrument 75 is then manipulated in such a manner so that a selected cardiac tissue (for instance, a papillary muscle, one or more leaflet tissues, chordae tendineae, or the like) is contacted with the functional distal portion 81 of the instrument 75 and a repair effectuated, for instance, a mitral or tricuspid valve repair.

In one embodiment, the instrument 75 is designed to extend and contract with the beat of the heart. During systolic contraction, the median axis 74 of the heart 10 shortens. The distance from the apex 72 of the heart (where the device is inserted) to the mitral leaflet 52, 54 varies by 1 – 2 cm with each heartbeat. Accordingly, the instrument 75 is designed such that the tip 84 of the device (i.e. the part that contacts the mitral leaflet 52, 54) is “floating” wherein each systole is associated with approximately 1 - 2 cm of outward extension of the device. Referring to Figures 6a – 6c, the instrument 75 includes an inner tube 89 and an outer tube 91. The inner tube 89 is configured to slide within the outer tube 91. A handle 87 is attached to the outer tube 91. A resilient element 94, such as a spring is present so that, as the outer tube 91 is advanced and the tip 84 makes contact with the leaflet 52, 54, the elongate portion 78, being connected to the inner tube 89, pushes against the resilient element 94. With forward pressure predetermined by the resilient element 94, once the tip 84 comes in contact with the leaflet 52, 54, even though the user continues to advance the instrument 75, the amount of pressure applied by the tip to the leaflet 52, 54 will remain constant as a result

of the presence of the resilient element 94. The resilient element 94 allows a defined, constant forward force on the leaflet 52, 54. A user may feel contact, but will also be able to confirm visually that the resilient element 94 is extending and contracting.

While a smaller seating surface enables the tip 84 to be more easily localized, it may be more likely to perforate the leaflet. A larger seating surface is more likely to remain in the selected location, but is harder to land on the leaflet 52, 54. Accordingly, in some embodiments, the delivery system may have a blunt end, to avoid pushing the entire device through the leaflet; to that end, a device with an expandable balloon 88 at the distal end, such as shown in Figure 7, may be provided.

The inflatable balloon 88 is provided at the tip 84. The balloon 88 can distribute pressure more widely on the underside of the leaflet 52, 54, and minimize the likelihood that the leaflet will be perforated unintentionally by the device. Such a balloon 88 can be configured to surround the tip 84, thereby providing a broader seating surface against the leaflet. Once the instrument 75 is inserted, the balloon 88 can be inflated using methods known in the art. For example, the instrument 75 may include an inner lumen 90 comprising annealed stainless steel surrounded by an outer tube 92 made of urethane or other flexible material. A clearance space 93 between the inner lumen 90 and the outer tube 92 provides an inflation lumen. The outer tube should be bonded at one end around the tip 84 and at the other end to a valve 95, such as a Touhy valve. The valve 95 is tightened to the inner lumen 90. An inflation port 98 is provided to enable inflation of the balloon 88. In some embodiments, the balloon 88 may provide an expanded seating surface of approximately 6 – 7 mm.

Preferably, characteristics of the end surface of the tip 84 include ease of location on the leaflet, tendency to remain in one location, does not harm the leaflet by penetration, and can serve as a platform to deploy one or more needles, as described below.

Figures 8a - 8f show exemplary stages of the tip portion 84 of an instrument 75 according to an embodiment of the present disclosure. In the embodiment illustrated in Figures 8a - 8f, the tip 84 has two channels; each channel contains a needle. Preferably, one channel contains a larger needle, such as a 20-gauge and the other channel contains a smaller needle. It is not necessary that the needles be different sizes, nor is the needle gauge particular to the practice of this disclosure; other sizes may be used. In some embodiments, the snare described below could be a smaller gauge than the suture, allowing the needles to be the same size. Preferably, the two needles are as far apart as possible in the tip 84, so as to make the resulting suture that is installed less likely to tear the leaflet. In Figure 8a, the

needles are retracted. In Figure 8b, both needles puncture the mitral valve leaflet (not shown); first the snare needle 151, then the suture needle 154. As shown in Figure 8c, a metal (steel, nitinol, or other material) snare 157 is advanced through the larger needle. The snare 157 is adapted so that the loop can be selectively retracted or extended within the larger
5 needle. The snare 157 is further adapted so that once it emerges (on the atrial side of the leaflet), it will deform in a predetermined manner, such as approximately a 90-degree bend, and is in position to capture a PTFE suture. While these steps may occur in rapid sequence, the snare 157 should not emerge until both needles have punctured the mitral valve leaflet. Preferably, the snare 157 includes a directional handle so that it is always deployed toward
10 the center of the tip 84. Figure 8d shows a PTFE suture 160 that is injected through the smaller needle (21 or 22 gauge) and passes through the deployed snare 157. Preferably, heparinized saline is used to inject the PTFE suture 160. As shown in Figure 8e, the snare 157 is withdrawn into the 20-gauge needle, capturing the PTFE suture 160. In Figure 8f, the device is removed, leaving a PTFE suture in the leaflet. An alternate approach would be to
15 advance a metal guide wire through the smaller needle, grasp it, and pull it back. The PTFE suture could then be tied to the guide wire and pulled through.

Figure 9 illustrates another embodiment using a “between the leaflets” approach for grasping and attaching a suture to a mitral valve leaflet 52, 54. In this embodiment, a shafted instrument 100 is inserted between two mitral valve leaflets 52, 54, as shown in Figure 9a.
20 Figure 9b shows a snare 103 and a stiff “upper stabilizer” 106 deployed at the end of the instrument 100. Preferably, the snare 103 extends at approximately a 90-degree angle from the shaft 109. Typically, the upper stabilizer 106 will have an angle of approximately 70 - 80° from the shaft. A user then pulls the instrument 100 back until the upper stabilizer 106 lands on the mitral leaflet 52. Essentially, the leaflet 52 is stabilized by the shaft 109 (on the
25 leading edge of the leaflet) and the snare stabilizer 106. Next, as shown in Figure 9c, a second stabilizer (a narrow snare or prong) 112 is deployed below the leaflet 52. Typically, the second stabilizer 112 will have an angle of approximately 50 - 60° from the shaft. The second stabilizer 112 is progressively advanced toward the upper stabilizer 106. The leaflet 52 is “grabbed” by the two stabilizers 106, 112. Once the leaflet 52 is grasped, as shown in
30 Figure 9d, a needle 115 is ejected at an angle from the shaft 109. The needle 115 penetrates the leaflet 52, and passes through the upper stabilizer 106 and the snare 103. A PTFE suture is then injected through the needle 115 and captured by the snare 103. The needle 115 can then be retracted while the snare 103 holds the suture. Next, the snare 103 is withdrawn with

the suture penetrating through the leaflet 52. The lower stabilizer 112 is withdrawn, followed by the upper stabilizer 106.

Another embodiment is shown in Figure 10. A slotted needle 165 is wrapped with a PTFE suture. The needle 165 can be as small as 22 gauge. In some embodiments, the needle
5 165 may be electropolished to make it smooth. Referring to Figure 10a, a suture 168 is prepared on the needle 165. Preferably, the suture is made of PTFE material. One end of the suture 168 emerges from a distal end 171 of the needle 165, and another end emerges from a slot 172. The suture 168 may have a simple knot 173 (see Figure 12) where it emerges from the distal end 171 of the needle 165 and another knot at the end of the wrapping near the slot
10 172. In some embodiments, small, temporary silicone rings (not shown) may be used to hold the suture 168 at the distal and proximal ends. As shown in Figure 10b, a first coil 175 is wound from the outside toward the inside (top to bottom). The suture 168 should be wrapped tightly around the needle 165 for approximately 20-200 turns. Other numbers of turns may be used. As shown in Figure 10c, a second coil 176 is wound from the outside toward the
15 inside (bottom to top). Again, the suture 168 should be wrapped tightly around the needle 165 for approximately 20-200 turns. Other numbers of turns may be used. A short section may be left in the center for threading and completing the rest of the knot. The ends of the suture 168 may be crossed and looped from the end of the distal coil in the distal direction or in the direction of the proximal coil. The knot can be tightened by sliding the two coils 175,
20 176 to the center and twisting the coils to take up the slack in the needle slot, as shown in Figure 10e. In some embodiments, a medical grade silicone may be used on the needle 165 and the wrapped suture 168 to allow smooth withdrawal of the needle 165 during subsequent procedure. Figure 11 shows a finished version of a needle 165 with a suture 168 wrapped thereon.

Referring to Figure 12, and particularly the portion labeled (a), the needle 165 has a suture 168 tightly wrapped around one end thereof. A pusher 177 or hollow guide wire may be provided on the needle 165. As shown in Figure 12b, the wrapped needle 165 is inserted into the heart toward the mitral valve leaflet 52. The wrapped needle 165 can be advanced across the mitral valve leaflet 52 until the end of the wrapping, indicated by 179, is in the
30 atrium above the leaflet 52, as shown in Figure 9c, leaving a small hole. In Figure 9d, the needle 165 is withdrawn, but the pusher 177 and suture 168 remain. In Figure 9e, a withdrawal force applied to the ends of the suture 168 resulting in the transformation of the tightly wrapped coil of the suture 168 into a bulky knot 180 as shown in Figure 9f. Lastly, as shown in Figure 9g, the pusher 177 is withdrawn, leaving the permanent bulky knot 180,

which anchors the suture 168 to the leaflet 52. In this embodiment, the resulting implant is made solely of a PTFE suture, which is a time-tested means of fixing the mitral valve.

There are many possible configurations of PTFE material and needle to form the bulky knot 180. For example, the suture 168 may form two or more loops, such as a figure 8. In some embodiments, the suture 168 may be double wrapped on the needle 165. Alternatively, the needle 165 may be non-hollow; that is, a solid needle. Figure 13 illustrates how the simple bulky knot 180, described above, is formed. In Figure 13a, the suture 168 is deployed. In Figure 13b, the withdrawal force applied to the ends of the suture 168 pulls the knot 173 toward the end of the wrapping 174. Once the two ends meet, the bulky knot 180 remains, as shown in Figure 13c.

In other words, according to the “bulky knot” concept: a PTFE suture 168 (or any kind of suture, or perhaps even a “filament”) is wrapped tightly around a small-gauge needle 165, near the tip. The needle 165 is then advanced through the valve leaflet 52. A “pusher” 177 surrounds the needle 165 and extends to the level of the “wrap” of suture/filament. Once the sharp point end of the needle and the wrap/coil of suture/filament 179 has passed through the leaflet 52, the needle 165 is withdrawn. This leaves the coil (s) 175, 176 unsupported. Tension on the ends of the filament/suture 168 at the base of the needle then cause a bulky knot 180 to form. Finally, the pusher 177 is pulled back, leaving a bulky knot 180 on the “far” side of the leaflet 52.

Figure 14 illustrates an alternate embodiment of the bulky knot described above. An additional bulky knot 182 is created below the leaflet 52. The additional bulky knot 182 will sandwich the leaflet 52 between two knots. The distance between the knots should be no more than the thickness of the leaflet 52. As shown in Figure 14b, a spacer 185 may be provided between the bulky knots 180, 182.

Referring to Figure 15, once one or more bulky knots 180 have been implanted to one or more cardiac tissues, lengthening or shortening of the artificial chordae can be performed by knotting, tying, cutting, anchoring, and otherwise manipulating the cords in a manner so as to achieve the desired (e.g., optimal) length. Once the optimal length of the neochord is determined, the suture 168 can be tied off and/or anchored, outside of the apex 72, by any means well known in the art, for instance, by tying one or more knots into the suture 168. One or more pledgets 143 may also be used.

According to embodiments herein, the bulky knot concept can be used for an Alfieri stitch; that is, an Alfieri stitch can be created by sequentially deploying a double helix knot

on first one leaflet of the mitral valve (i.e., the anterior leaflet 52), followed by the posterior leaflet 54, then tying the two together, using a knot pusher deployed from the apex 72.

Furthermore, while the embodiments disclosed herein are described with reference to a heart valve leaflet. The concepts are equally applicable to penetrating and applying similar knots to the annulus 60 of the valves. In some embodiments, several bulky knots 180 may be installed in the annulus 60 and tied together.

Figure 16 shows another embodiment in which an expansile element 121 has been created. One approach for the expansile element 121 is a standard guide wire 125 made of an elongated spring formed of steel, nitinol, or other material. The guide wire 125 may be coated with PTFE or other appropriate coating. Alternatively, the guide wire 125 may remain uncoated. The guide wire 125 should be appropriately sized, such as 0.9 mm. Other sizes may be used. The expansile element 121 includes a suture 128 in the core. Preferably, the suture 128 is made of PTFE. The suture 128 is woven through the guide wire 125 as illustrated in Figure 16 so that pulling on the suture 128 causes deformation of the tip of the expansile element 121 into a figure of 8 (or similar) configuration. Figure 17 shows the progression of the expansile element 121 from an inactivated form as shown in Figure 17a to a partially activated form in Figure 17b, then to a fully activated form in Figure 17c. The fully activated form may be in a spiral or helical shape or have one, two, three, or more loops, as desired.

Using an expansile element 121, a single-needle puncture procedure can be performed. As shown in Figure 18, a neochord implant 131 that contains an expansile element 121 on the tip can be deployed once it has passed through the leaflet 52. The neochord implant 131 is inside an appropriately sized needle 134. The needle 134 may be 20-gauge, 19-gauge, 18-gauge, or other appropriate size. The needle 134 is used to penetrate the leaflet 52 and is then withdrawn, leaving the neochord implant 131 in place. The expansile element 121 is activated by pulling on the suture 128 causing deformation of the expansile element 121 at the tip into a predetermined configuration such as shown at 136, which keeps the implant 131 in place.

In some embodiments, the expansile element 121 may be self-forming; that is, the expansile element 121 can be made of a pre-shaped “memory” metal that is inserted into the needle 134. Withdrawal of the needle 134 allows the expansile element 121 to form its required shape.

Alternatively, as shown in Figure 19, an appropriately sized needle 137 or fine wire may be located inside the neochord implant 131. As above, the needle 137 is used to

penetrate the leaflet 52 and is then withdrawn, leaving the neochord implant 131 in place. An advantage of having the needle 137 inside the implant 131 is that it enables tighter tolerance between the implant 131 and the leaflet 52. Additionally, if a fine wire is used, it could also be used to activate the expansile element 121 instead of the suture 128.

5 Figure 20 shows an alternate configuration for the expansile element 121. An additional loop 140 is created below the leaflet 52. The additional loop 140 will sandwich the leaflet 52 between two loops of the implant 131. The distance between the loops should be no more than the thickest a leaflet 52 could be. As the additional loop 140 is formed, it will conform to the thickness of the leaflet 52.

10 Referring to Figure 21, once one or more implants 131 have been implanted to one or more cardiac tissues, the implantation device is removed through the access (e.g., via the access port), and the tail ends of the suture(s) 128 are trailed therethrough. Artificial chordae lengthening or shortening can be performed by knotting, tying, cutting, anchoring, and otherwise manipulating the cords in a manner so as to achieve the desired (e.g., optimal) length. Once the optimal length of the neochord is determined, the suture 128 can be tied off and/or anchored, outside of the apex 72, by any means well known in the art, for instance, by tying one or more knots into the suture 128. One or more pledgets 143 may also be used.

In another approach, the neochord implant 131 of the present disclosure herein can be used in an edge-to-edge (Alfieri) repair, as shown in Figure 22. A first implant 131 is
20 deployed on one leaflet 52. A second implant 131 is deployed on the second leaflet 54. The two implants are then banded together to create adjoining edges.

The sutures that are to be implanted (for instance, so as to function as artificial chordae tendinae or neochords) may be fabricated from any suitable material, such as but not limited to: polytetrafluoroethylene (PTFE), nylon, Gore-Tex, Silicone, Dacron, or the like.
25 With respect to the implantation of artificial chordae, the particular function of the replacement cord is dependent upon the configuration, physical characteristics and relative positioning of the structure(s). In certain embodiments, the structures act to restrain the abnormal motion of at least a portion of one or more of the valve leaflets. In other embodiments, the prosthetic chordae provide a remodeling as well as a leaflet restraint
30 function where the latter may address latent or residual billowing of the leaflet body and/or latent or residual prolapsing of the leaflet edge, either of which may result from the remodeling itself or from a physiological defect.

It is to be noted that a fundamental challenge in successfully replacing one or more chordae tendineae and restoring proper functioning of a cardiac valve, is determining the

appropriate artificial cord length and securing the artificial cord at a location so as to ensure the optimal replacement chordae length. The valve will not function properly if the length of the artificial cord is too long or too short. Because the heart is stopped using conventional techniques, it is virtually impossible to ensure that the cords are of the correct length and are
5 appropriately spaced inside the ventricle to produce a competent valve. Accordingly, methods of the disclosure herein include the measuring and determining of the optimal arrangement, length, placement, and configuration of an implanted suture, for instance, a replacement cord length, while the heart is still beating and, typically, before the access site of the heart is closed. An optimal arrangement of a suture, for instance, an optimal cord
10 length, is that arrangement that effects said repair, for instance, by minimizing reperfusion as determined by means well known in the art, for instance, by direct echo guidance.

Therefore, in accordance with the methods of the disclosure herein, once one or more artificial chordae have been implanted to one or more cardiac tissues, the implantation device is removed through the access (e.g., via the access port), and as stated above, the tail ends of
15 the suture(s) are trailed therethrough. The optimal length of the implanted suture(s) (i.e., neochord) can then be determined by manipulating the ends of the suture(s) in a graded and calibrated fashion that is akin to manipulating a marionette. The manipulation of the artificial chordae may be done in conjunction with audio or visual assistance means, for instance, direct echo (e.g., echocardiographic) guidance, by which the degree and extent of
20 regurgitation can be measured while the chordal length is being manipulated, so as to determine a chordal length that minimizes any observed regurgitation. Since, in a preferred embodiment, the heart is still beating the degree of cardiac regurgitation can be evaluated real time and the optimal neochord(s) length determined. Accordingly, an optimal cord length is a cord length that is determined, for instance, by direct echo guidance, to minimize or at least
25 reduce cardiac valve regurgitation. Artificial chordae lengthening or shortening can be performed, as described above, by knotting, tying, cutting, anchoring, and otherwise manipulating the cords in a manner so as to achieve the desired (e.g., optimal) length. Once the optimal length of the neochord is determined, the sutures can be tied off and/or anchored, outside of the apex, by any means well known in the art, for instance, by tying one or more
30 knots into the suture. One or more pledgets may also be used.

Once the corrective procedures are completed, the repaired valve may be further assessed, and if the repair is deemed satisfactory, the one or more devices (e.g., cannulae, sheath, manifold, access port, etc.) are removed, the access closed, as described above, and the percutaneous incisions are closed in a fashion consistent with other cardiac surgical

procedures. For instance, one or more purse-string sutures may be implanted at the access site of the heart and/or other access sites, so as to close the openings.

It is further contemplated that the devices and methods disclosed herein can be used in procedures outside the heart. That is, while the embodiments have been described with
5 reference to a heart valve, the devices and methods described above may be used in any procedure that requires penetrating a tissue and forming a knot on the far side thereof.

The present disclosure has been described with references to specific embodiments. While particular values, relationships, materials and steps have been set forth for purposes of describing concepts of the disclosure herein, it will be appreciated by persons skilled in the
10 art that numerous variations and/or modifications may be made to the disclosure herein as shown in the disclosed embodiments without departing from the spirit or scope of the basic concepts and operating principles of the disclosure herein as broadly described. It should be recognized that, in the light of the above teachings, those skilled in the art could modify those specifics without departing from the disclosure herein taught herein. Having now fully set
15 forth certain embodiments and modifications of the concept underlying the present disclosure herein, various other embodiments as well as potential variations and modifications of the embodiments shown and described herein will obviously occur to those skilled in the art upon becoming familiar with such underlying concept. It is intended to include all such
20 modifications, alternatives and other embodiments insofar as they come within the scope of the appended claims or equivalents thereof. It should be understood, therefore, that the disclosure herein might be practiced otherwise than as specifically set forth herein. Consequently, the present embodiments are to be considered in all respects as illustrative and not restrictive.

CLAIMS

What is claimed is:

- 1 1. A device for minimally invasive repair of a defective valve in a human heart, said
2 device comprising:
3 a shock absorbing mechanism; and
4 a deployable mechanism;
5 said shock absorbing mechanism being configured for placement adjacent to a
6 leaflet of said defective valve while said heart is beating; and
7 said deployable mechanism comprising:
8 a first part to pierce said leaflet; and
9 a second part to connect said leaflet to said heart in a vicinity of an
10 apex of said heart.
- 1 2. The device according to claim 1, said shock absorbing mechanism further comprising:
2 a first tube and a second tube, said first tube being at least partially within said second
3 tube; and
4 a resilient element within said second tube, said resilient element engaging an end of
5 said first tube.
- 1 3. The device according to claim 2, said resilient element comprising a spring.
- 1 4. The device according to claim 1, said deployable mechanism further comprising an
2 elongate member having a functional distal portion.
- 1 5. The device according to claim 4, said functional distal portion further comprising a tip
2 configured for repairing tissue of a cardiac valve.
- 1 6. The device according to claim 5, said tip including an inflatable balloon.
- 1 7. The device according to claim 5, said tip further comprising:
2 a first needle in a first channel in said tip; and
3 a second needle in a second channel in said tip,
4 a snare being provided from said first needle and a suture being provided from
5 said second needle.
- 1 8. The device according to claim 7, said first needle being larger than said second
2 needle.
- 1 9. The device according to claim 7, said snare, upon emerging from said first needle,
2 assuming a bend position to capture said suture.
- 1 10. The device according to claim 9, said snare further including a directional handle that
2 deploys said snare toward a center of said tip.

- 1 11. The device according to claim 1, said deployable mechanism further comprising an
2 expansile element.
- 1 12. The device according to claim 11, said expansile element being self-forming.
- 1 13. The device according to claim 11, said expansile element comprising a guide wire and
2 a suture, said suture being woven in said guide wire.
- 1 14. The device according to claim 13, deformation of said expansile element into a
2 shaped configuration being caused by applying a pulling force on said suture.
- 1 15. The device according to claim 13, said guide wire comprising an elongate spring.
- 1 16. The device according to claim 11, further comprising a needle.
- 1 17. The device according to claim 16, said expansile element being deployed inside said
2 needle.
- 1 18. The device according to claim 16, said needle being deployed inside said expansile
2 element.
- 1 19. The device according to claim 1, said deployable mechanism further comprising a
2 needle, said needle having suture material wrapped around an end thereof.
- 1 20. The device according to claim 19, said needle being wrapped approximately 20 – 200
2 times.
- 1 21. The device according to claim 19, said suture material comprising PTFE.
- 1 22. The device according to claim 19, said needle being hollow, and said suture emerging
2 from a distal end of said needle.
- 1 23. A device for minimally invasive repair of a defective valve of a human heart, said
2 device comprising:
3 a hollow shaft containing:
4 a snare;
5 an upper stabilizer; and
6 a second stabilizer
7 said snare and said upper stabilizer being deployable from an end of said
8 hollow shaft; and
9 said second stabilizer being located away from said end of said hollow
10 shaft, and
11 said second stabilizer being moveable in relation to said upper stabilizer.
- 1 24. The device according to claim 23, said snare extending approximately 90° from said
2 hollow shaft.

- 1 25. The device according to claim 23, said upper stabilizer extending approximately 70° -
2 80° from said hollow shaft.
- 1 26. The device according to claim 23, said second stabilizer extending approximately 50°
2 - 60° from said hollow shaft.
- 1 27. The device according to claim 23, further comprising a needle deployed from said
2 shaft, said needle penetrates a leaflet of said defective valve and passes through said upper
3 stabilizer and said snare.
- 1 28. The device according to claim 27, further comprising a suture with said needle.
- 1 29. A method for repairing a defective mitral valve or tricuspid valve, comprising:
2 creating an access in an apical region of a heart;
3 introducing a device through said access; and
4 repairing said cardiac valve by use of said device,
5 said repairing comprising:
6 replacing one or more chordae tendineae, and
7 using said device to implant one or more artificial chordae tendineae,
8 said one or more artificial chordae tendineae being at least partially deployed
9 through one or more leaflets of said heart.
- 1 30. The method according to claim 29, said artificial chordae tendineae comprising an
2 expansile element.
- 1 31. The method according to claim 30, said expansile element being self-forming.
- 1 32. The method according to claim 30, said expansile element comprising a guide wire
2 and a suture, said suture being woven in said guide wire.
- 1 33. The method according to claim 32, deformation of said expansile element into a
2 shaped configuration being caused by pulling on said suture.
- 1 34. The method according to claim 32, said guide wire comprising an elongate spring.
- 1 35. The method according to claim 30, said repairing said cardiac valve by use of said
2 device further comprising:
3 piercing a leaflet of said cardiac valve with a needle; and
4 deploying said expansile element from said needle.
- 1 36. The method according to claim 35, said expansile element being deployed inside said
2 needle.
- 1 37. The method according to claim 35, said needle being deployed inside said expansile
2 element.

- 1 38. The method according to claim 29, said repairing said cardiac valve by use of said
2 device further comprising:
3 piercing a leaflet of said cardiac valve with a needle, said needle having a suture
4 material wrapped around an end thereof;
5 withdrawing said needle while leaving said suture material; and
6 forming a knot in said suture material.
- 1 39. The method according to claim 38, said suture material comprising PTFE.
- 1 40. The method according to claim 38, said needle being deployed inside a pusher
2 element, said method further comprising:
3 when withdrawing said needle, leaving said pusher element;
4 forming a knot in said suture material by applying a withdrawal force to ends of said
5 suture against said pusher element; and
6 after said knot is formed, withdrawing said pusher element.
- 1 41. The method according to claim 29, said device further comprising a shock absorbing
2 mechanism being configured for placement adjacent to a leaflet of said defective valve while
3 said heart is beating.
- 1 42. The method according to claim 41, said shock absorbing mechanism further
2 comprising:
3 a first tube and a second tube, said first tube being at least partially within said second
4 tube; and
5 a resilient element within said second tube, said resilient element engaging an end of
6 said first tube.
- 1 43. The method according to claim 42, said resilient element comprising a spring.
- 1 44. The method of claim 29, said repair being performed while said heart is beating.
- 1 45. The method of claim 29, said method being a minimally invasive procedure.
- 1 46. The method of claim 29, said method further comprising use of endoscopy.
- 1 47. The method of claim 29, said introduction of said device being performed in
2 conjunction with sonography or direct transblood visualization.
- 1 48. The method of claim 29, said repairing said cardiac valve by use of said device further
2 comprising:
3 anchoring said one or more artificial chordae tendineae to tissue in said apical region
4 of said heart.
- 1 49. The method of claim 48, said tissue being internal to said heart.

- 1 50. The method of claim 48, said tissue being one of a papillary muscle, a papillary
2 connective tissue, and an endocardial tissue in a lower ventricle of said heart.
- 1 51. The method of claim 48, further comprising determining an optimal configuration of
2 said one or more artificial chordae tendineae before anchoring said artificial chordae
3 tendineae.
- 1 52. The method of claim 51, said determining an optimal configuration of said one or
2 more artificial chordae tendineae comprising use of sonic guidance.
- 1 53. The method of claim 51, said artificial chordae tendineae being anchored to said
2 tissue subsequent to said determination.
- 1 54. The method of claim 29, said repairing said cardiac valve comprising performing a
2 bow-tie Alfieri procedure.

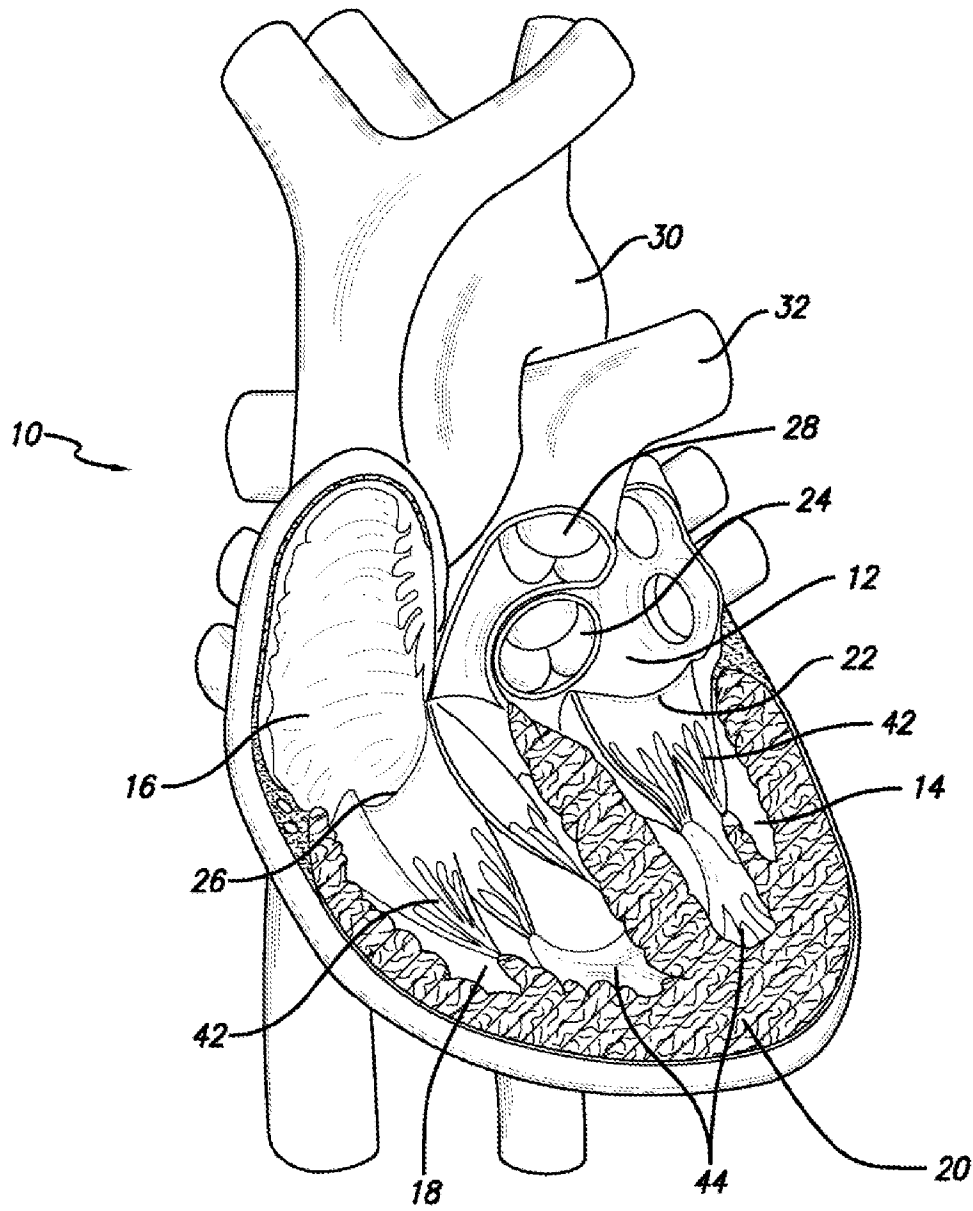

FIG. 1

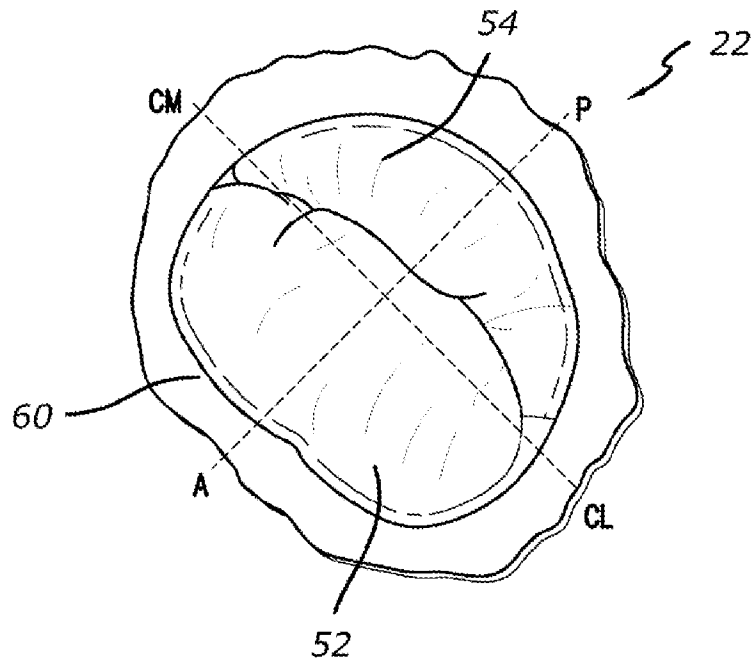

FIG. 2

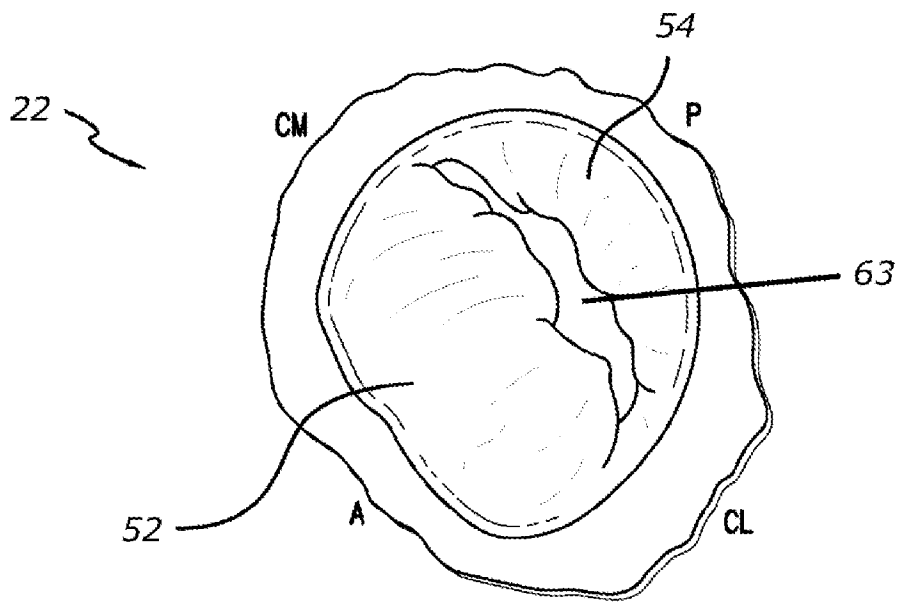

FIG. 3

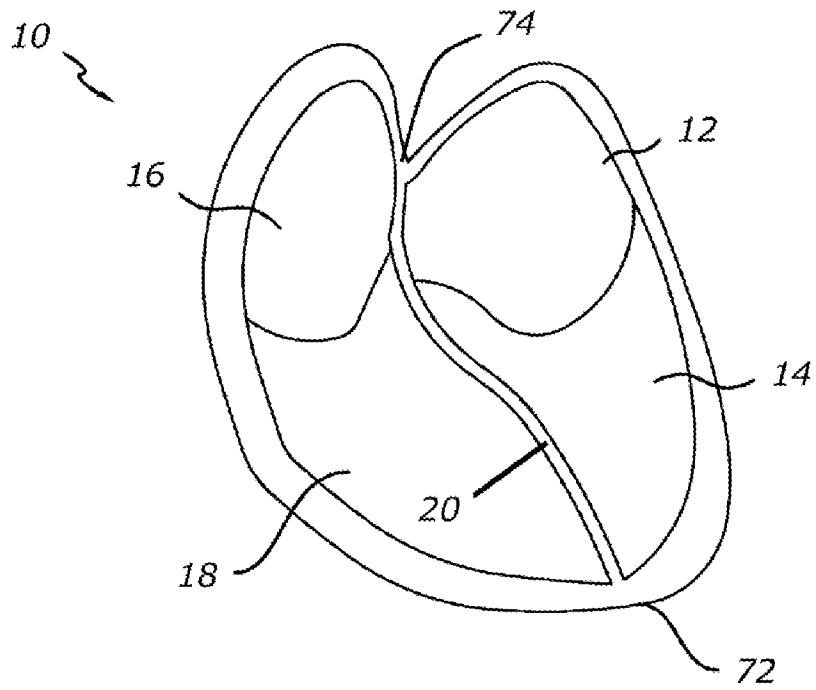

FIG. 4

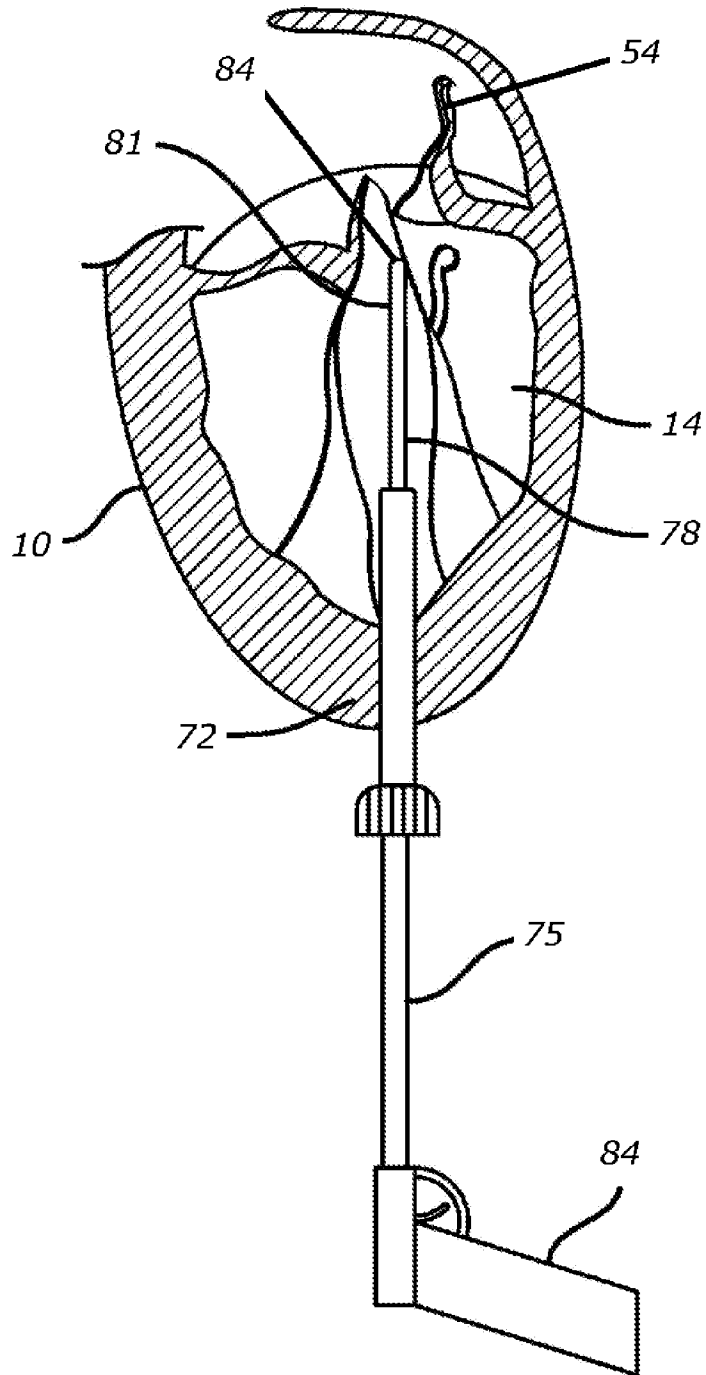

FIG. 5

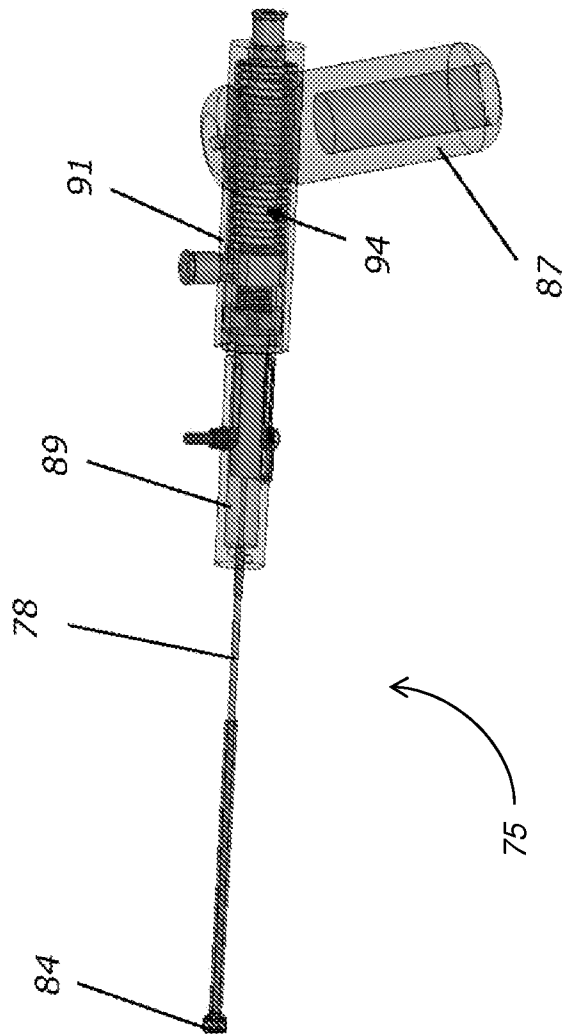

FIG. 6a

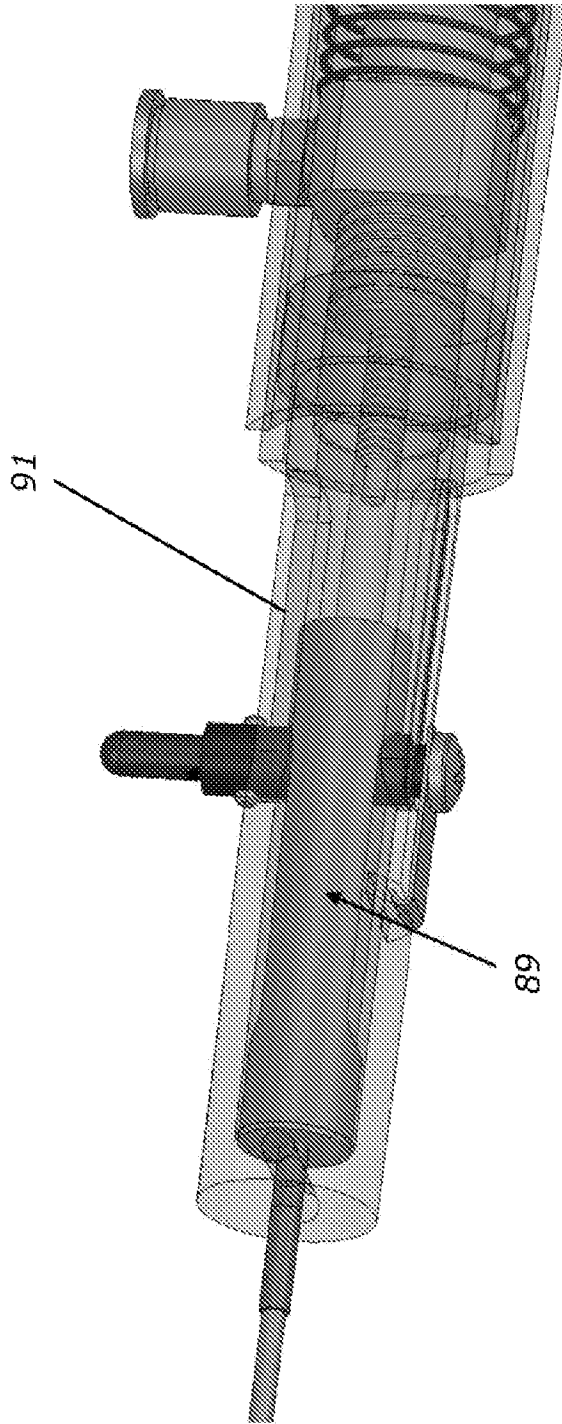

FIG. 6b

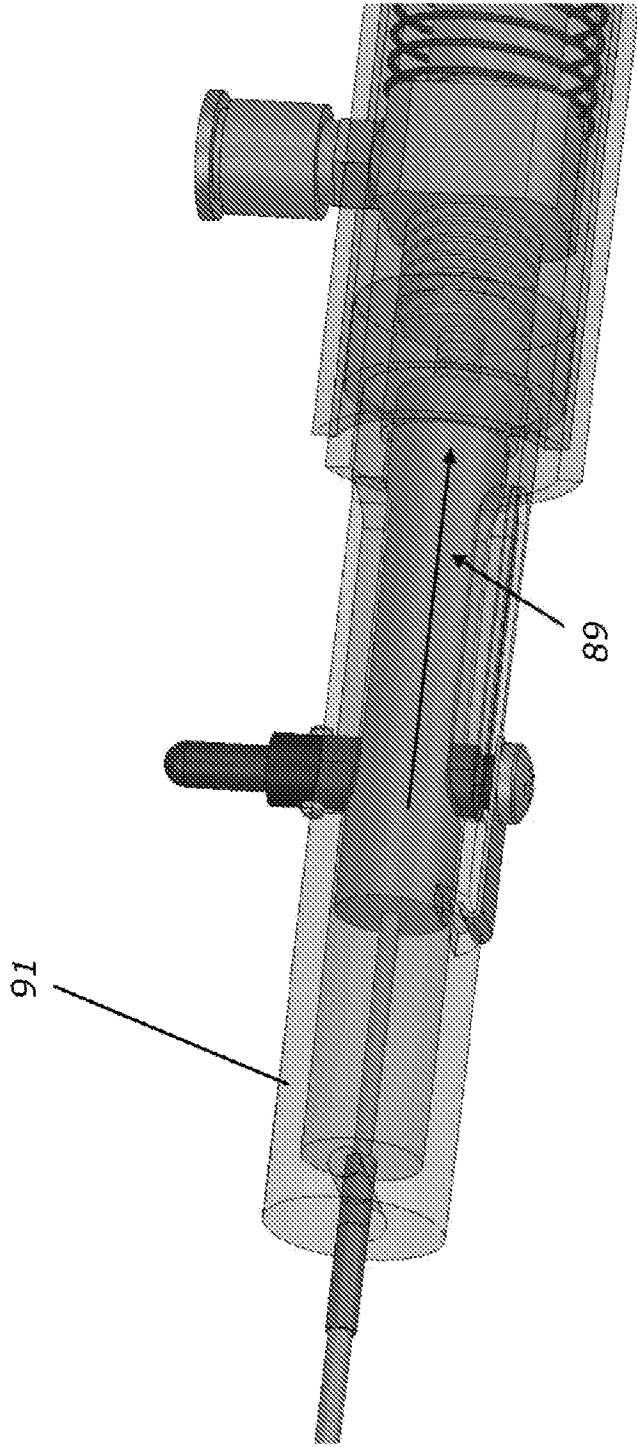

FIG. 6C

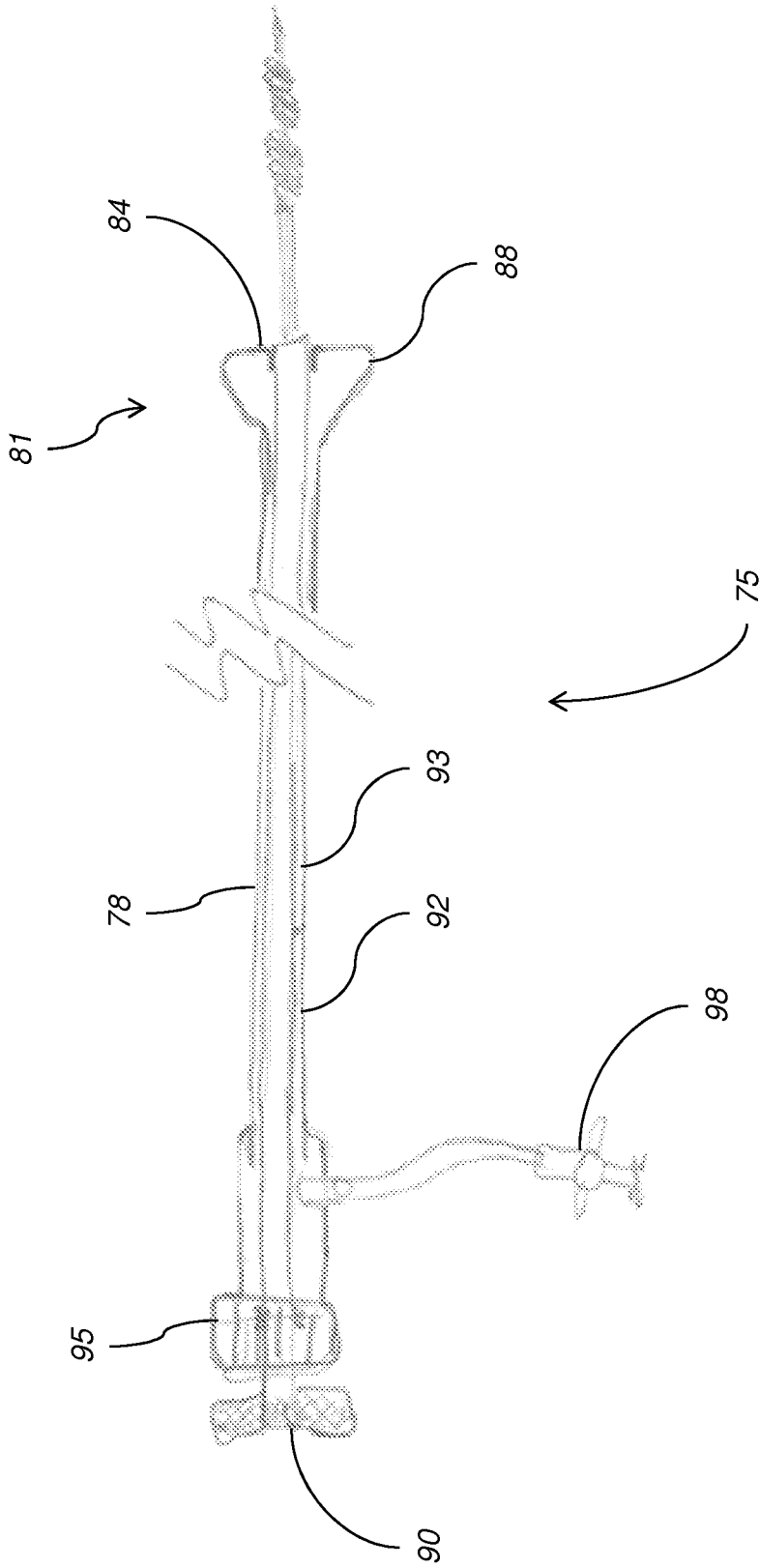

FIG. 7

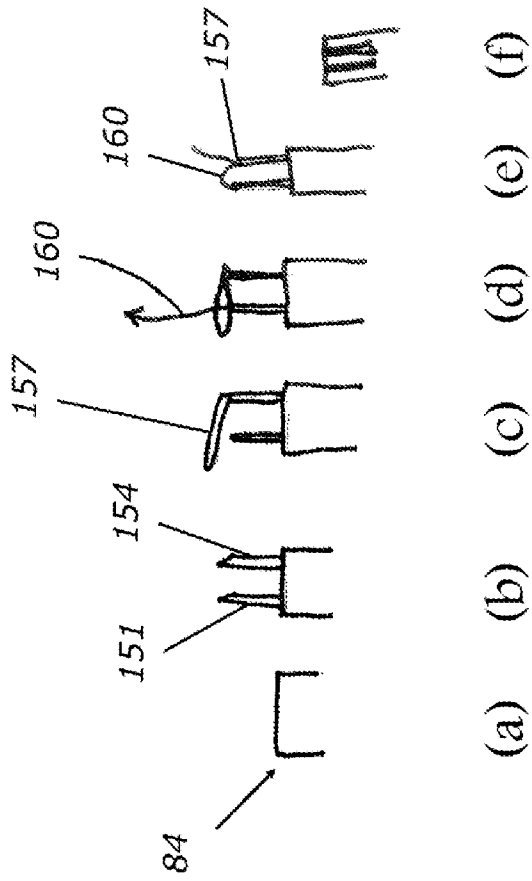

FIG. 8

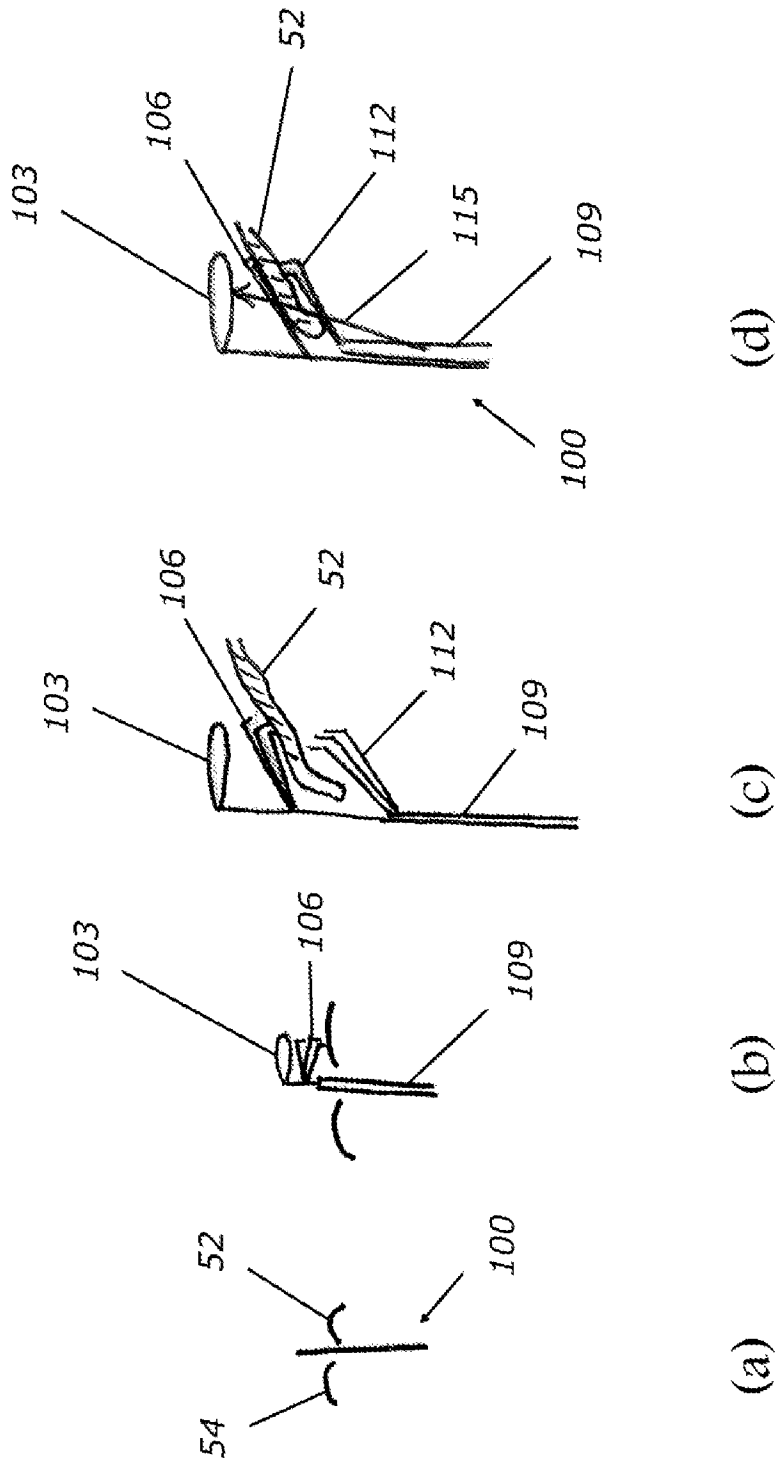

FIG. 9

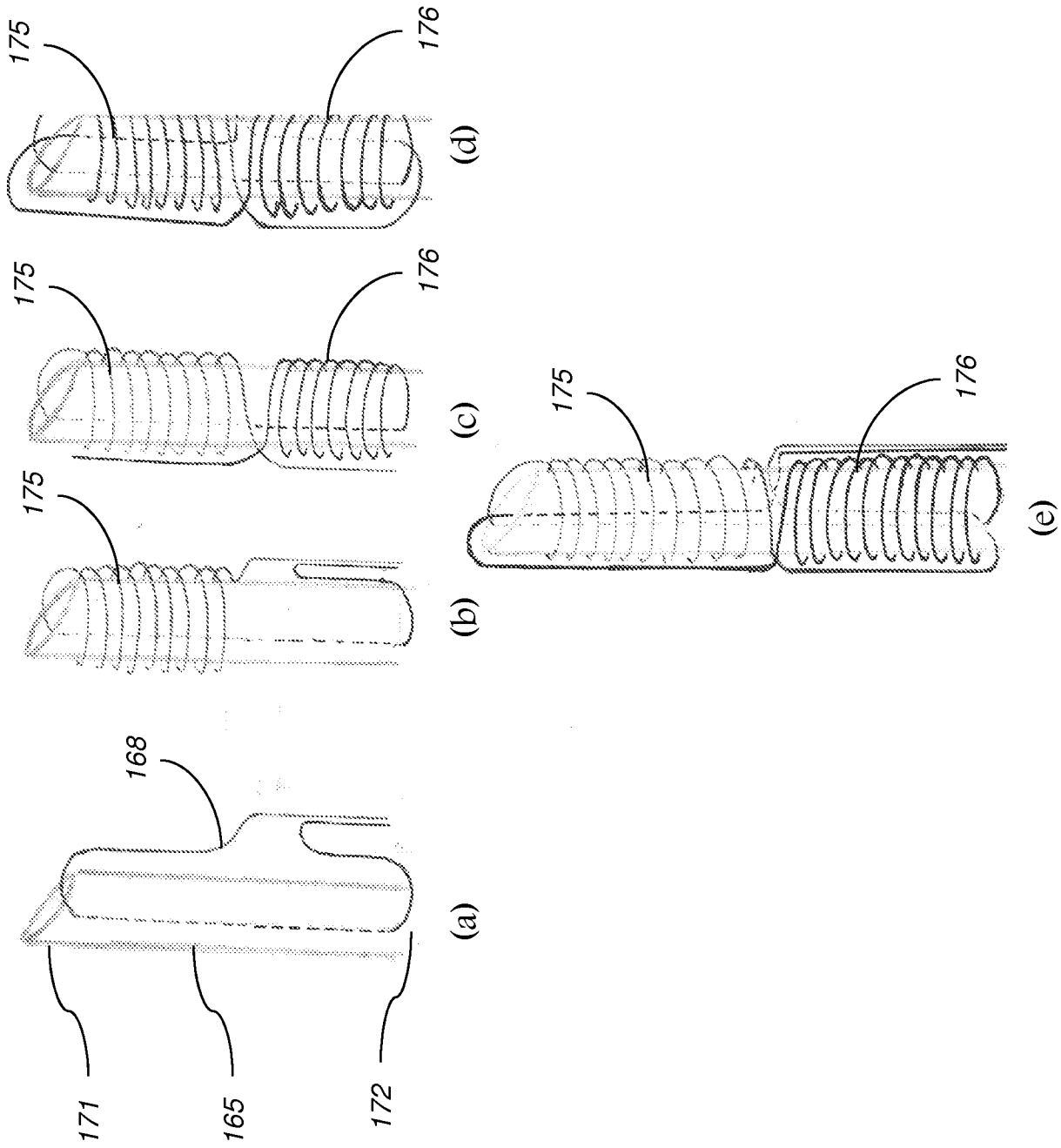

FIG. 10

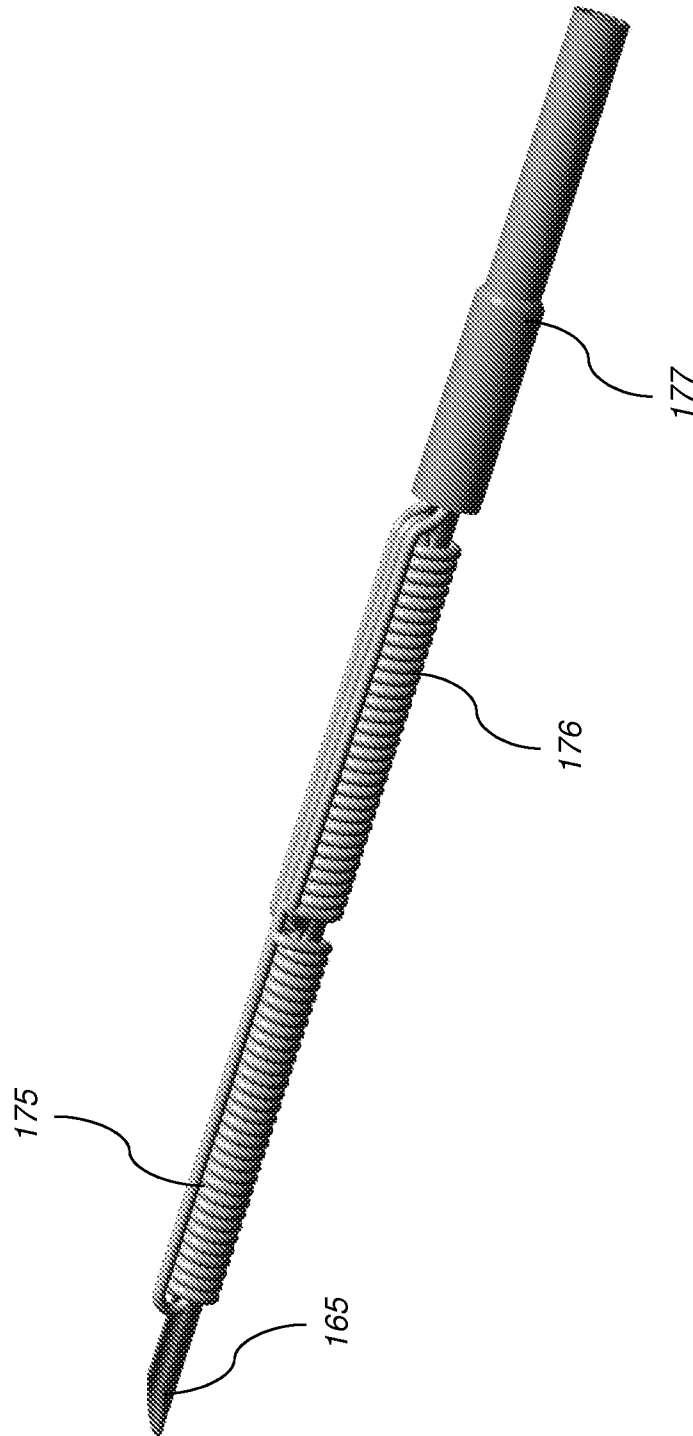

FIG. 11

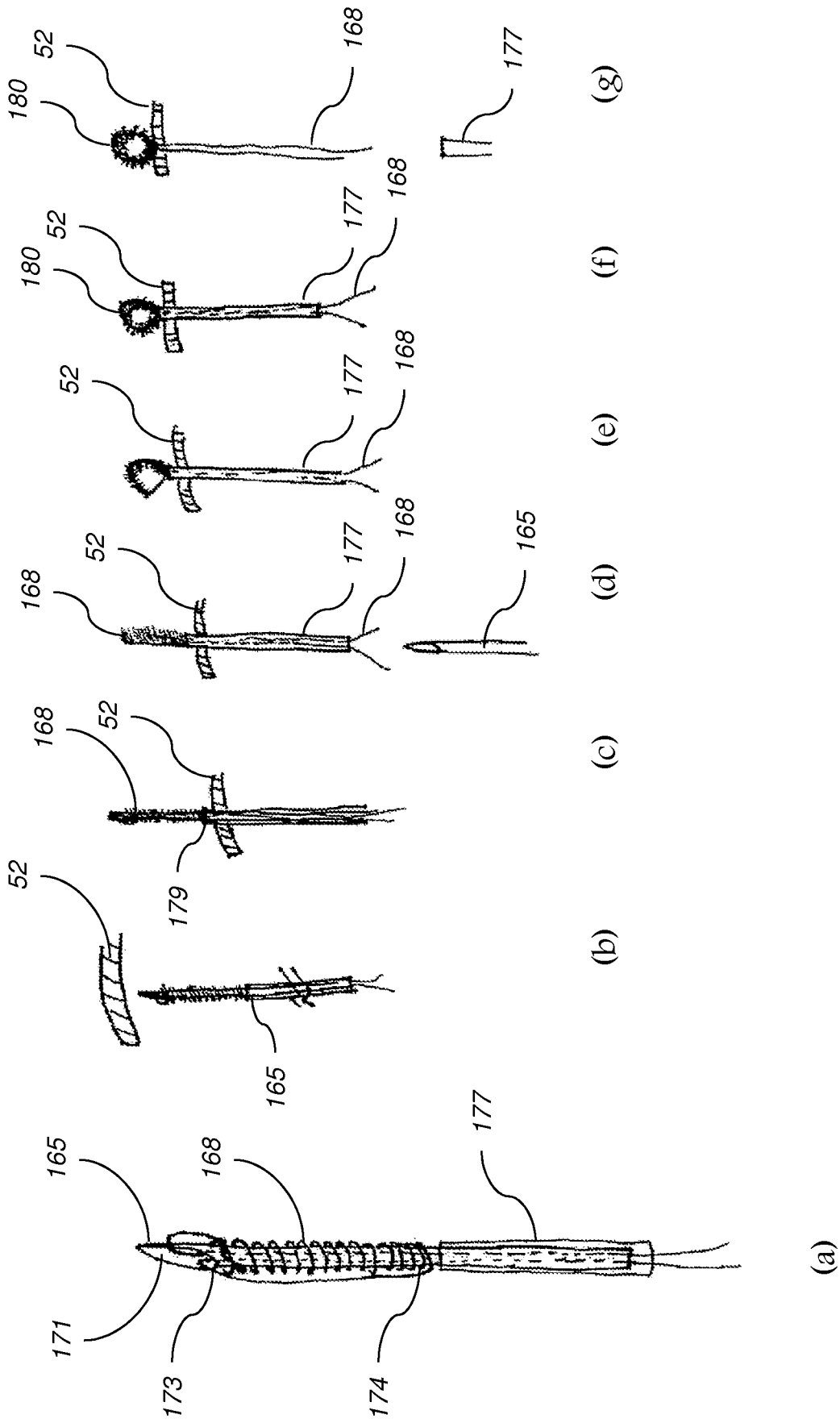

FIG. 12

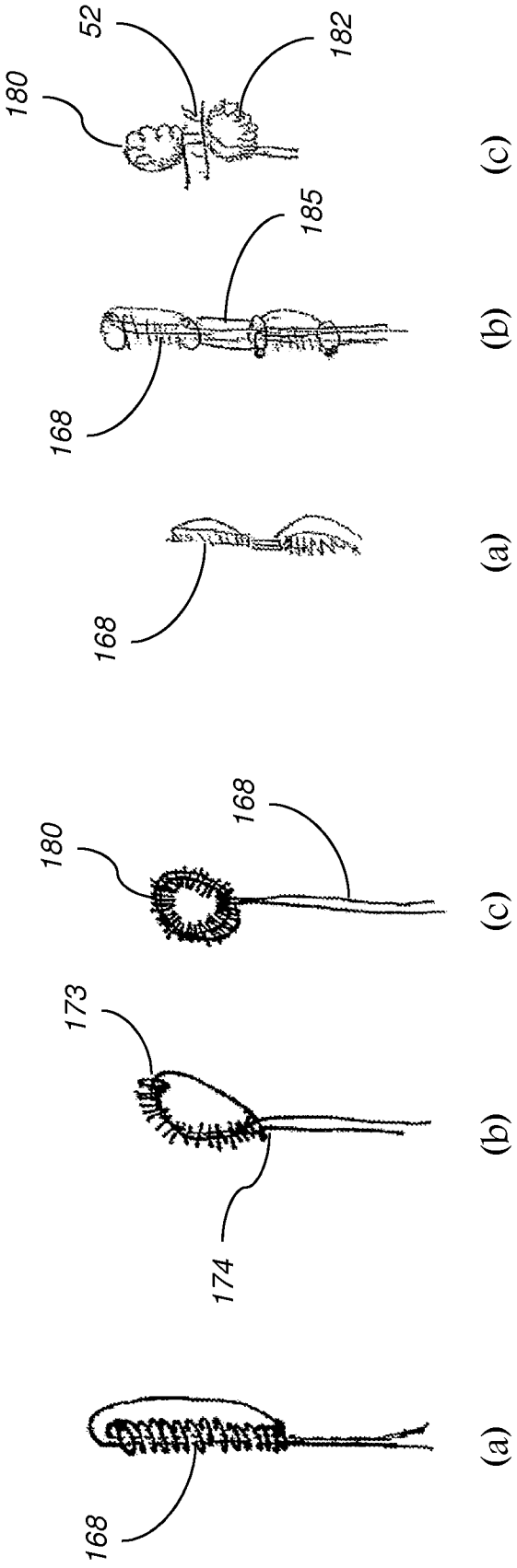

FIG. 14

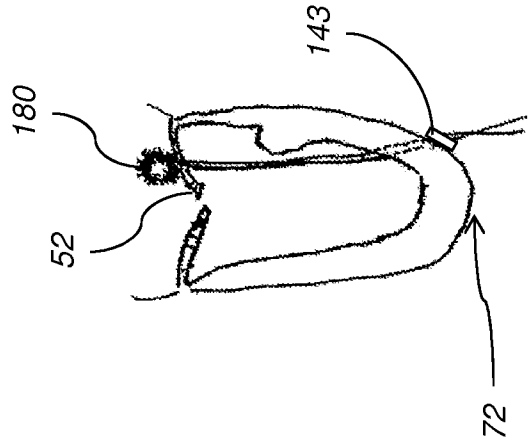

FIG. 15

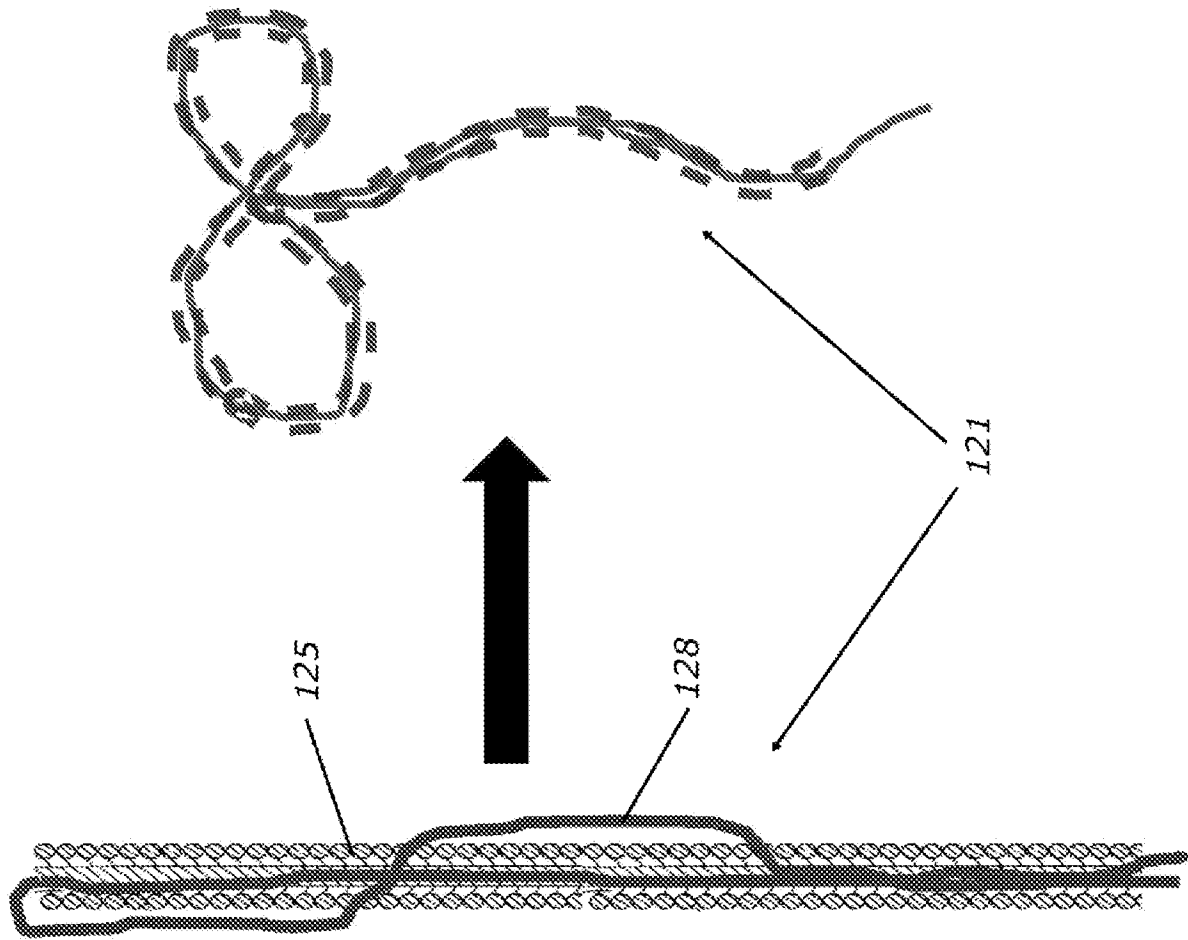

FIG. 16

16/20

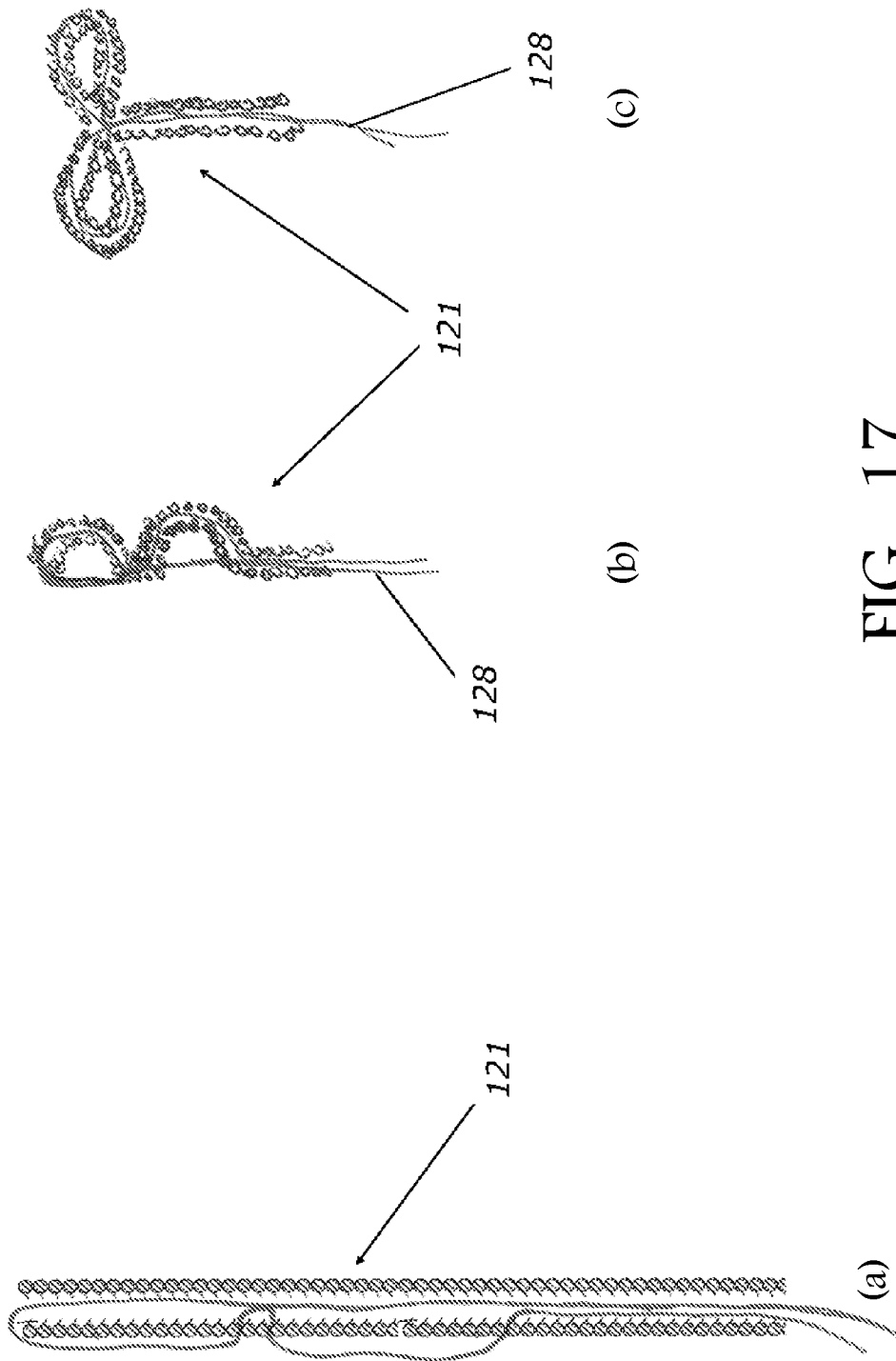

FIG. 17

17/20

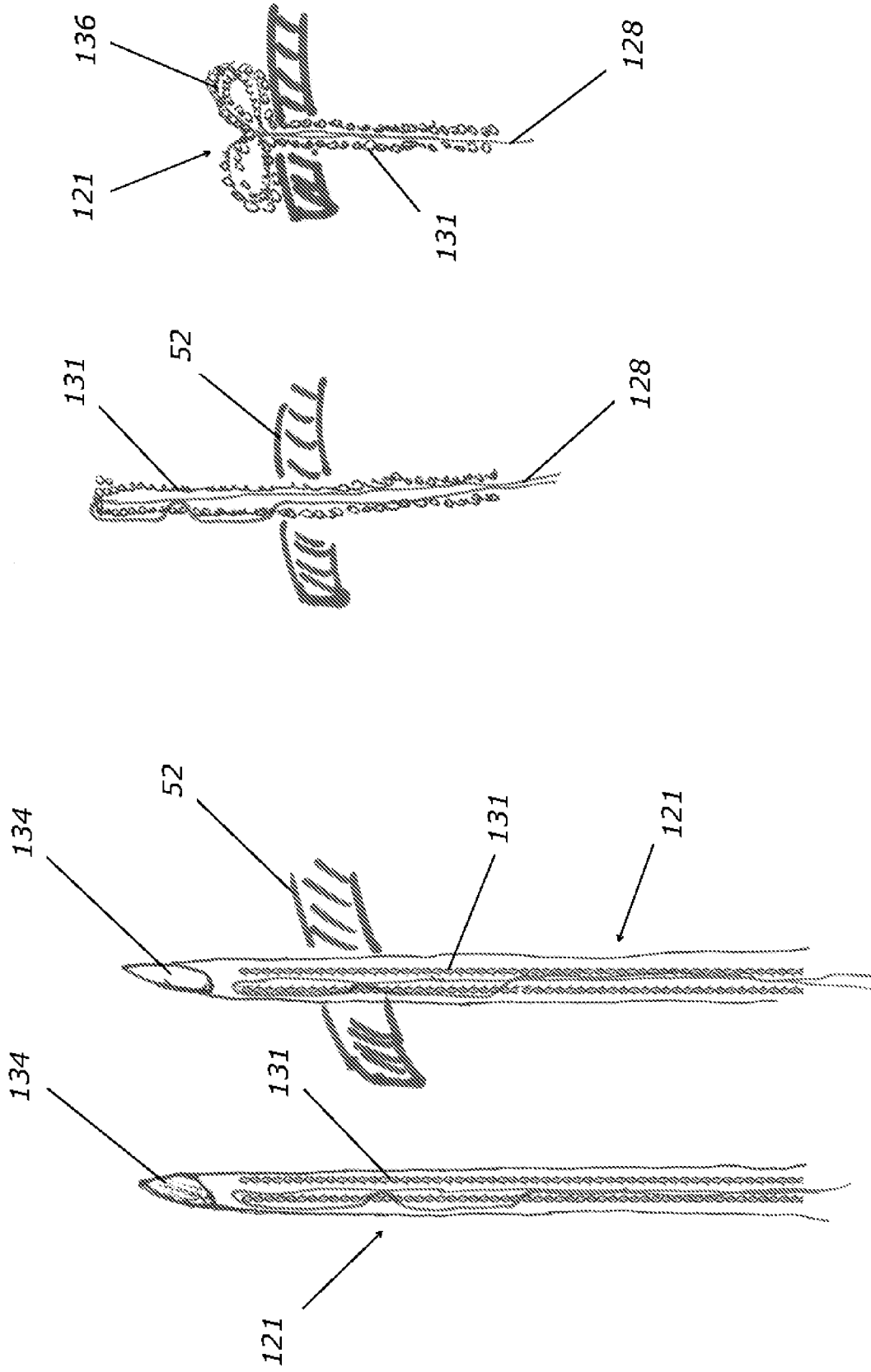

FIG. 18

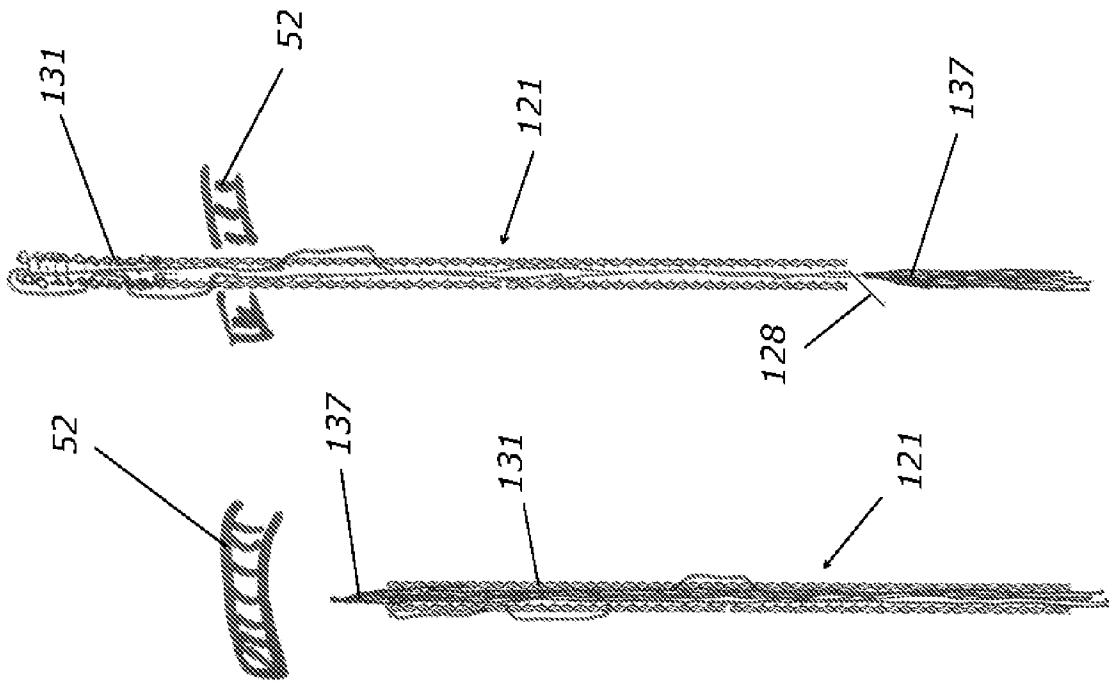

FIG. 19

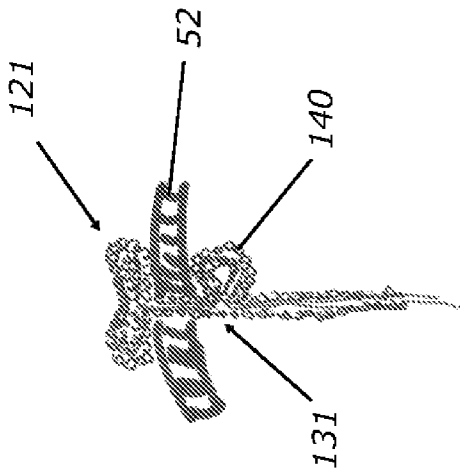

FIG. 20

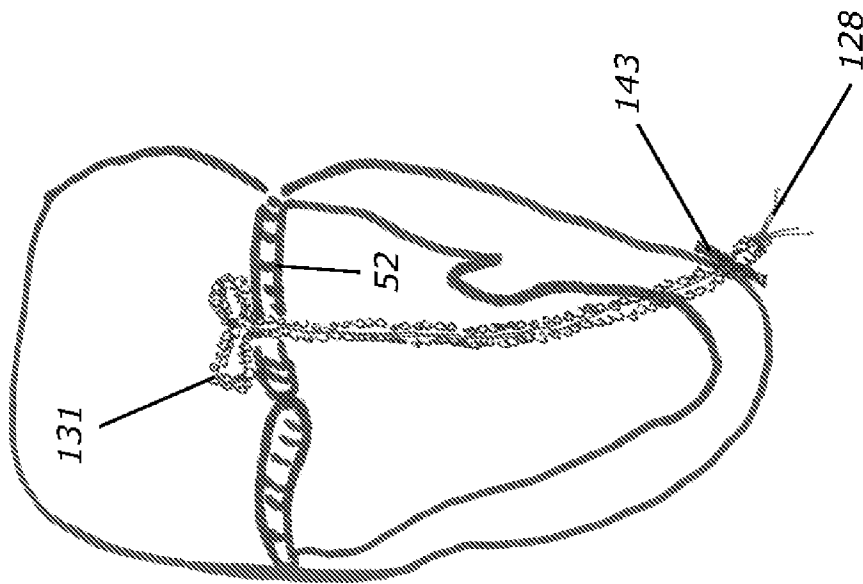

FIG. 21

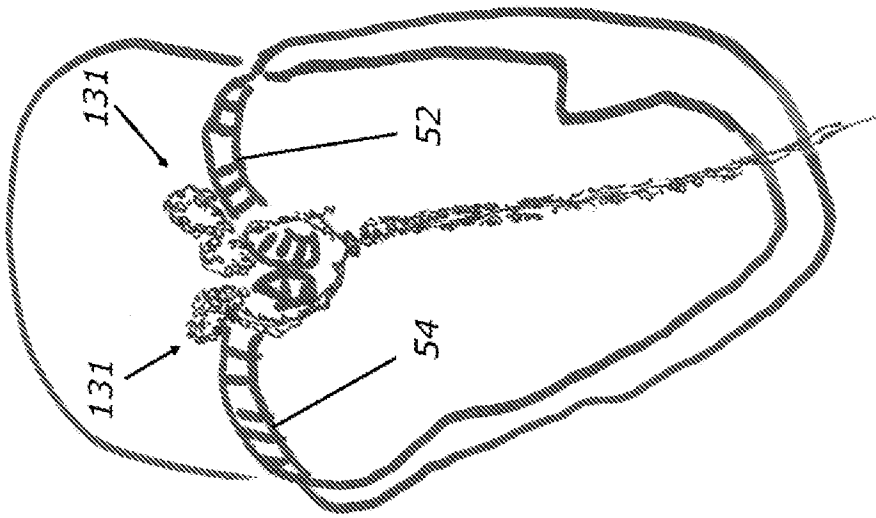

FIG. 22

A. CLASSIFICATION OF SUBJECT MATTER*A61F 2/78(2006.01)i, A61F 2/76(2006.01)i, A61F 2/24(2006.01)i, A61M 39/22(2006.01)i*

According to International Patent Classification (IPC) or to both national classification and IPC

B. FIELDS SEARCHED

Minimum documentation searched (classification system followed by classification symbols)

A61F 2/78; A61B 17/138; A61F 2/24; A61B 17/10; A61F 13/00; A61F 2/00; A61B 17/062; A61B 17/08

Documentation searched other than minimum documentation to the extent that such documents are included in the fields searched

Korean utility models and applications for utility models

Japanese utility models and applications for utility models

Electronic data base consulted during the international search (name of data base and, where practicable, search terms used)

eKOMPASS(KIPO internal) & Keywords: heart, shock, absorbing, deployable, leaflet, apex, elongate, inflatable, ballon, needle, tip, expansile, spring, suture, snare, shaft, stabilizer

C. DOCUMENTS CONSIDERED TO BE RELEVANT

Category*	Citation of document, with indication, where appropriate, of the relevant passages	Relevant to claim No.
X A	US 2008-0228223 A1 (ALKHATIB, Y. F.) 18 September 2008 See abstract; figures 1,25,43; paragraphs [0051],[0060],[0074]; claim 17.	1-6 7-28
X A	US 2007-0118151 A1 (DAVIDSON, M. J.) 24 May 2007 See abstract; figure 8; paragraphs [0088],[0089]; claim 78.	23-28 1-22
X A	US 2010-0174297 A1 (SPEZIALI, G.) 08 July 2010 See abstract; figures 8A-D; paragraphs [0040]-[0044]; claim 1.	23-26 1-22,27,28
A	US 2007-0213582 A1 (ZOLLINGER, C. J. & ADZICH, W. V.) 13 September 2007 See the whole document.	1-28
A	US 2011-0029071 A1 (ZLOTNICK, A. et al.) 03 February 2011 See the whole document.	1-28
A	US 7635386 B1 (GAMMIE, J. S.) 22 December 2009 See the whole document.	1-28

 Further documents are listed in the continuation of Box C. See patent family annex.

* Special categories of cited documents:

"A" document defining the general state of the art which is not considered to be of particular relevance

"E" earlier application or patent but published on or after the international filing date

"L" document which may throw doubts on priority claim(s) or which is cited to establish the publication date of citation or other special reason (as specified)

"O" document referring to an oral disclosure, use, exhibition or other means

"P" document published prior to the international filing date but later than the priority date claimed

"T" later document published after the international filing date or priority date and not in conflict with the application but cited to understand the principle or theory underlying the invention

"X" document of particular relevance; the claimed invention cannot be considered novel or cannot be considered to involve an inventive step when the document is taken alone

"Y" document of particular relevance; the claimed invention cannot be considered to involve an inventive step when the document is combined with one or more other such documents, such combination being obvious to a person skilled in the art

"&" document member of the same patent family

Date of the actual completion of the international search

27 NOVEMBER 2012 (27.11.2012)

Date of mailing of the international search report

03 DECEMBER 2012 (03.12.2012)

Name and mailing address of the ISA/KR

Korean Intellectual Property Office
189 Cheongsu-ro, Seo-gu, Daejeon Metropolitan
City, 302-701, Republic of Korea

Facsimile No. 82-42-472-7140

Authorized officer

JEONG, JAE CHEOL

Telephone No. 82-42-481-8403



INTERNATIONAL SEARCH REPORT

International application No.

PCT/US2012/043761

C (Continuation). DOCUMENTS CONSIDERED TO BE RELEVANT		
Category*	Citation of document, with indication, where appropriate, of the relevant passages	Relevant to claim No.
A	WO 2007-100268 A2 (BABIC, U.) 07 September 2007 See the whole document.	1-28

Box No. II Observations where certain claims were found unsearchable (Continuation of item 2 of first sheet)

This international search report has not been established in respect of certain claims under Article 17(2)(a) for the following reasons:

1. Claims Nos.: 29-54
because they relate to subject matter not required to be searched by this Authority, namely:
Claims 29-54 pertain to methods for treatment of the human body by surgery or therapy, and thus relate to a subject matter which this International Searching Authority is not required, under Article 17(2)(a)(i) of PCT and Rule 39.1(iv) of the Regulations under the PCT, to search.
2. Claims Nos.:
because they relate to parts of the international application that do not comply with the prescribed requirements to such an extent that no meaningful international search can be carried out, specifically:
3. Claims Nos.:
because they are dependent claims and are not drafted in accordance with the second and third sentences of Rule 6.4(a).

Box No. III Observations where unity of invention is lacking (Continuation of item 3 of first sheet)

This International Searching Authority found multiple inventions in this international application, as follows:

1. As all required additional search fees were timely paid by the applicant, this international search report covers all searchable claims.
2. As all searchable claims could be searched without effort justifying an additional fee, this Authority did not invite payment of any additional fee.
3. As only some of the required additional search fees were timely paid by the applicant, this international search report covers only those claims for which fees were paid, specifically claims Nos.:
4. No required additional search fees were timely paid by the applicant. Consequently, this international search report is restricted to the invention first mentioned in the claims; it is covered by claims Nos.:

Remark on Protest

- The additional search fees were accompanied by the applicant's protest and, where applicable, the payment of a protest fee.
- The additional search fees were accompanied by the applicant's protest but the applicable protest fee was not paid within the time limit specified in the invitation.
- No protest accompanied the payment of additional search fees.

INTERNATIONAL SEARCH REPORT

Information on patent family members

International application No.

PCT/US2012/043761

Patent document cited in search report	Publication date	Patent family member(s)	Publication date
US 2008-0228223 A1	18.09.2008	EP 2131788 A2	16.12.2009
		JP 2010-521225 A	24.06.2010
		WO 2008-112237 A2	18.09.2008
		WO 2008-112237 A3	29.01.2009
US 2007-0118151 A1	24.05.2007	WO 2007-062054 A2	31.05.2007
		WO 2007-062054 A3	25.10.2007
US 2010-0174297 A1	08.07.2010	AU 2006-206591 A1	27.07.2006
		AU 2006-206591 B2	25.08.2011
		CA 2595459 A1	27.07.2006
		CN 101495049 A	29.07.2009
		CN 101495049 B	15.12.2010
		EP 1845861 A2	24.10.2007
		EP 1845861 A4	09.12.2009
		EP 1845861 B1	22.06.2011
		JP 04-960262 B2	30.03.2012
		JP 2008-536528 A	11.09.2008
		US 2008-0188873 A1	07.08.2008
		WO 2006-078694 A2	27.07.2006
		WO 2006-078694 A3	16.04.2009
US 2007-0213582 A1	13.09.2007	EP 1998688 A2	10.12.2008
		EP 1998688 B1	21.12.2011
		US 2009-0043153 A1	12.02.2009
		US 7431692 B2	07.10.2008
		US 7871368 B2	18.01.2011
		WO 2007-103562 A2	13.09.2007
		WO 2007-103562 A3	13.03.2008
		US 2011-0029071 A1	03.02.2011
WO 2009-081396 A2	02.07.2009		
WO 2009-081396 A3	20.08.2009		
WO 2010-070649 A1	24.06.2010		
US 7635386 B1	22.12.2009	None	
WO 2007-100268 A2	07.09.2007	EP 2023822 A2	18.02.2009
		WO 2007-100268 A3	02.10.2008