



US009105784B2

(12) **United States Patent**
Ishiguro

(10) **Patent No.:** **US 9,105,784 B2**

(45) **Date of Patent:** **Aug. 11, 2015**

(54) **SOLAR MODULE**

(71) Applicant: **Sanyo Electric Co., Ltd.**, Moriguchi, Osaka (JP)

(72) Inventor: **Tasuku Ishiguro**, Kobe (JP)

(73) Assignee: **Panasonic Intellectual Property Management Co., Ltd.**, Osaka (JP)

(*) Notice: Subject to any disclaimer, the term of this patent is extended or adjusted under 35 U.S.C. 154(b) by 34 days.

(21) Appl. No.: **14/026,288**

(22) Filed: **Sep. 13, 2013**

(65) **Prior Publication Data**

US 2014/0014160 A1 Jan. 16, 2014

Related U.S. Application Data

(63) Continuation of application No. PCT/JP2012/054894, filed on Feb. 28, 2012.

(30) **Foreign Application Priority Data**

Mar. 16, 2011 (JP) 2011-058332

(51) **Int. Cl.**

H01L 31/054 (2014.01)
H01L 31/052 (2014.01)
H01L 31/048 (2014.01)

(52) **U.S. Cl.**

CPC **H01L 31/0527** (2013.01); **H01L 31/048** (2013.01); **H01L 31/0547** (2014.12); **Y02E 10/52** (2013.01)

(58) **Field of Classification Search**

USPC 136/256–259
See application file for complete search history.

(56) **References Cited**

U.S. PATENT DOCUMENTS

2006/0107991 A1* 5/2006 Baba 136/244
2010/0147363 A1* 6/2010 Huang et al. 136/251
2012/0138119 A1* 6/2012 Peng et al. 136/246

FOREIGN PATENT DOCUMENTS

JP 1999-307791 * 11/1999
JP H11-307791 A 11/1999
JP 2006-147984 A 6/2006
JP 2011-029273 * 2/2011
JP 2011-029273 A 2/2011

* cited by examiner

Primary Examiner — Jayne Mershon

(74) *Attorney, Agent, or Firm* — Marvin A. Motsenbocker; Mots Law, PLLC

(57) **ABSTRACT**

A solar module having improved photoelectric conversion efficiency is provided. The solar module (1) is provided with a bifacial light-receiving solar cell (10), a transparent member (15), a weather-resistant member (14), and a bonding layer (13). The bonding layer (13) includes at least two media (13b, 13c) having different refractive indices. Interfaces (22, 23) are formed by at least two media (13b, 13c) and are positioned in a region unoccupied by the solar cells (10). The interfaces (22, 23) are configured such that at least some of the light that is incident on the interfaces (22, 23) in a direction (z) perpendicular to the solar module (1) is guided to the back surface (10b) of the solar cells (10).

5 Claims, 5 Drawing Sheets

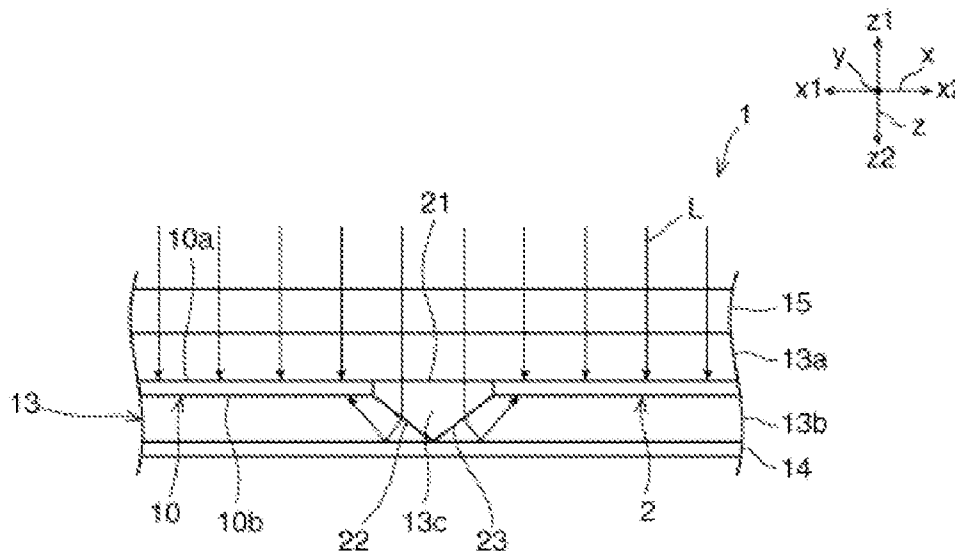

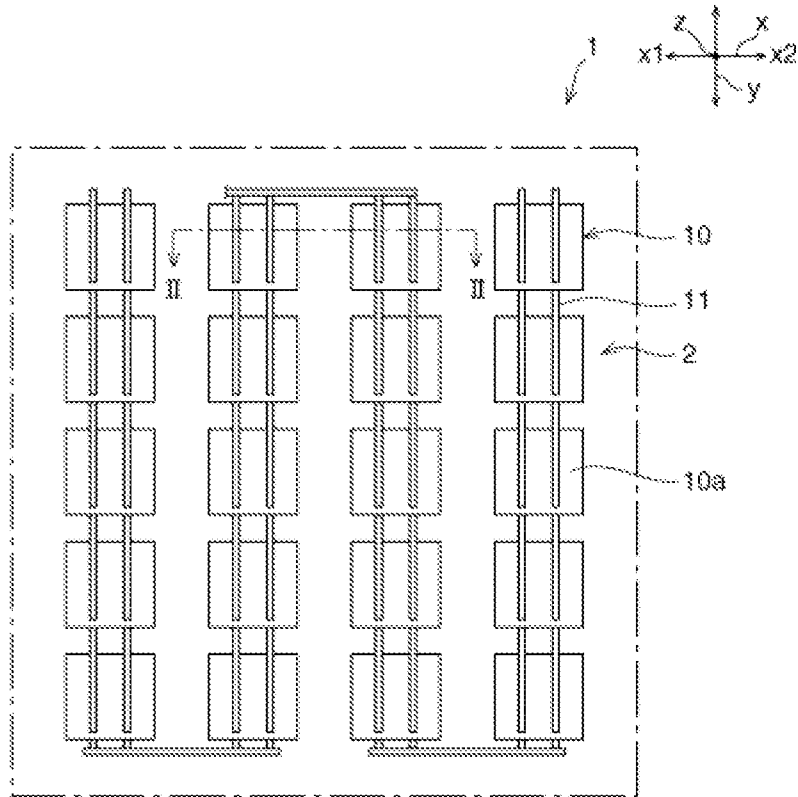

FIG. 1

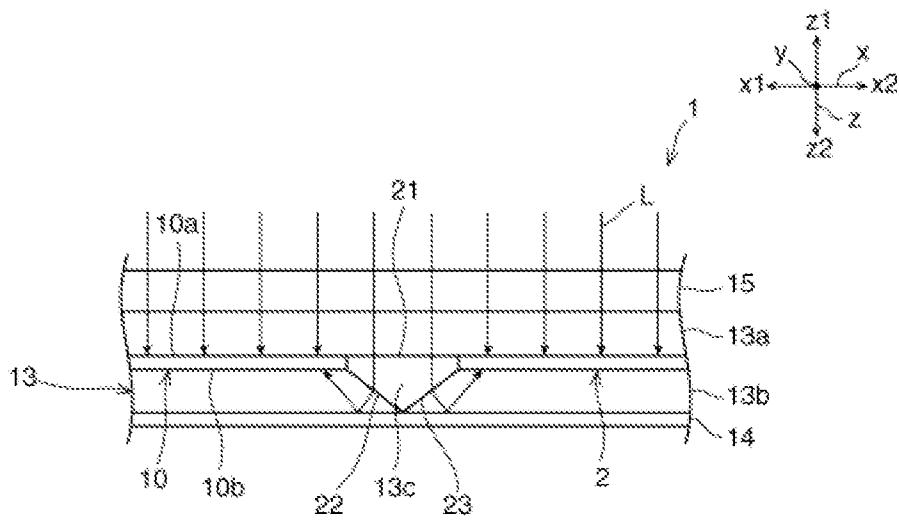

FIG. 2

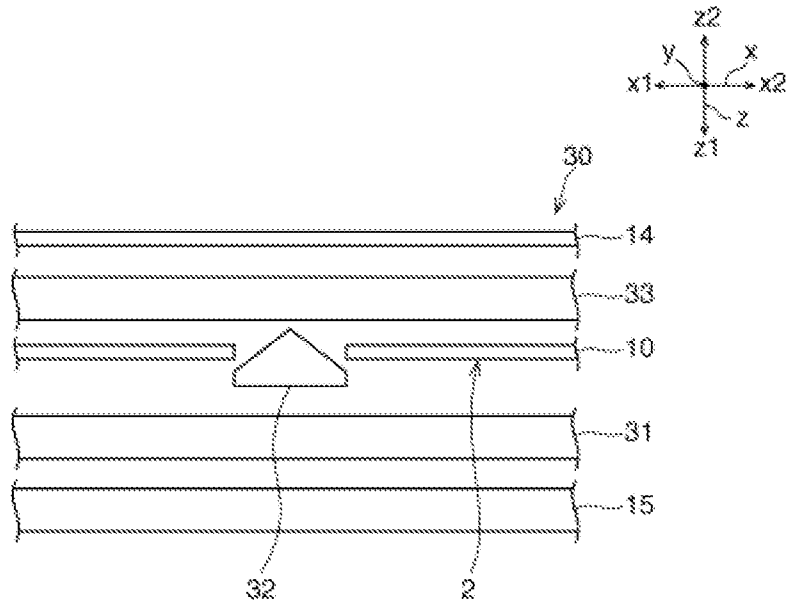

FIG. 3

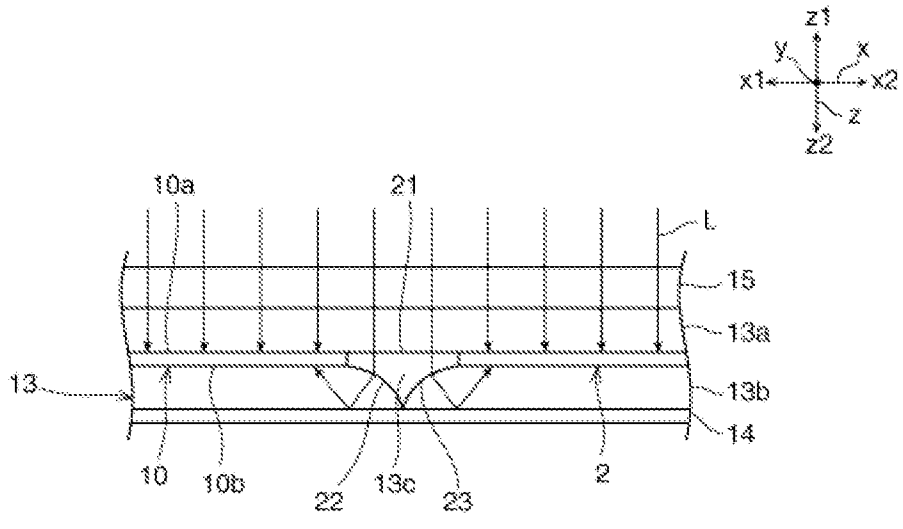

FIG. 4

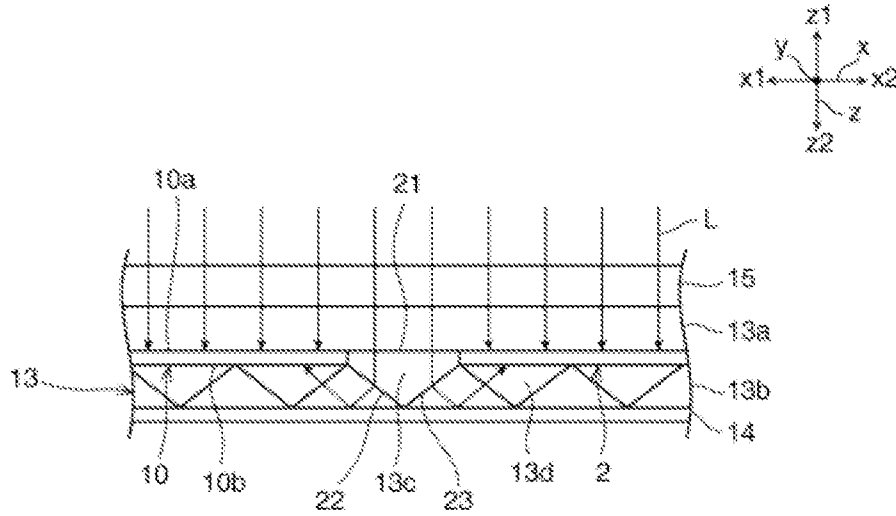

FIG. 5

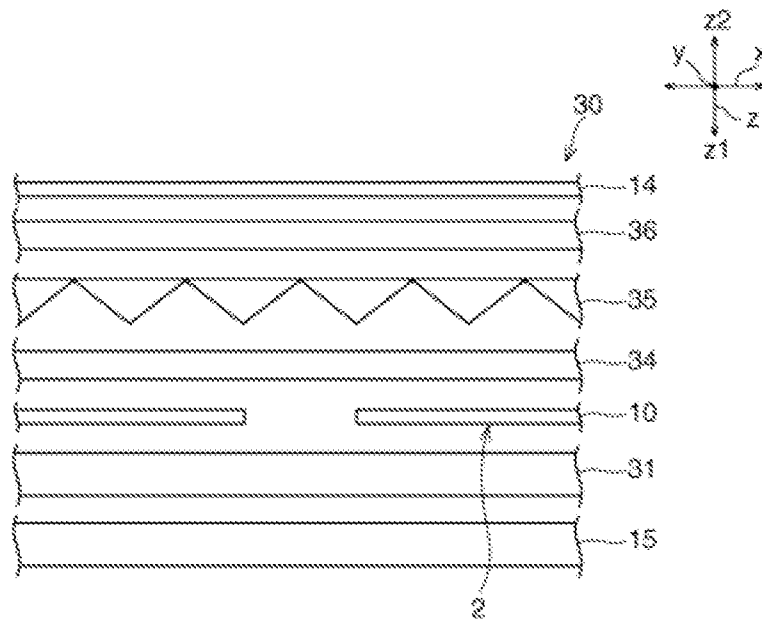

FIG. 6

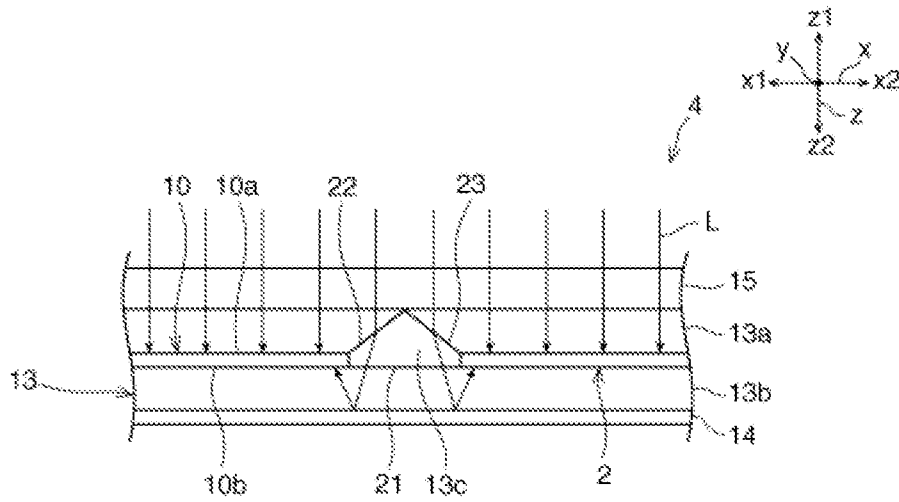

FIG. 7

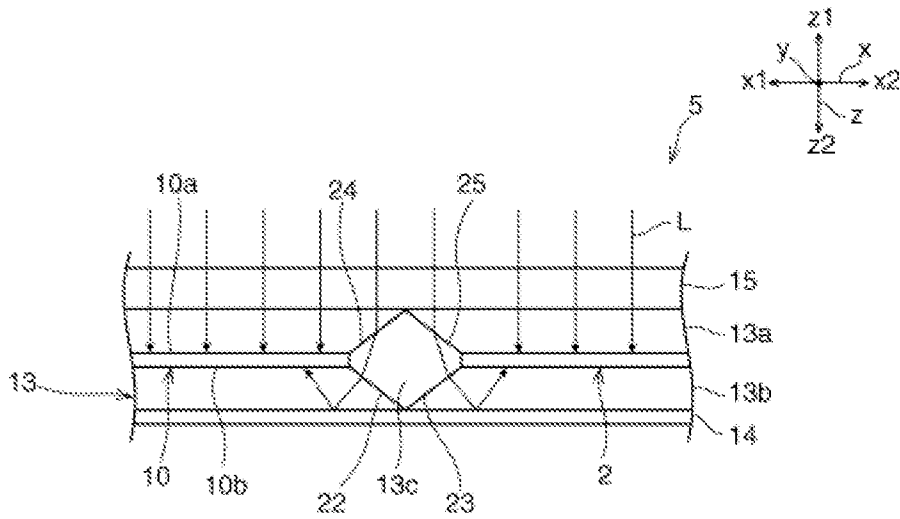

FIG. 8

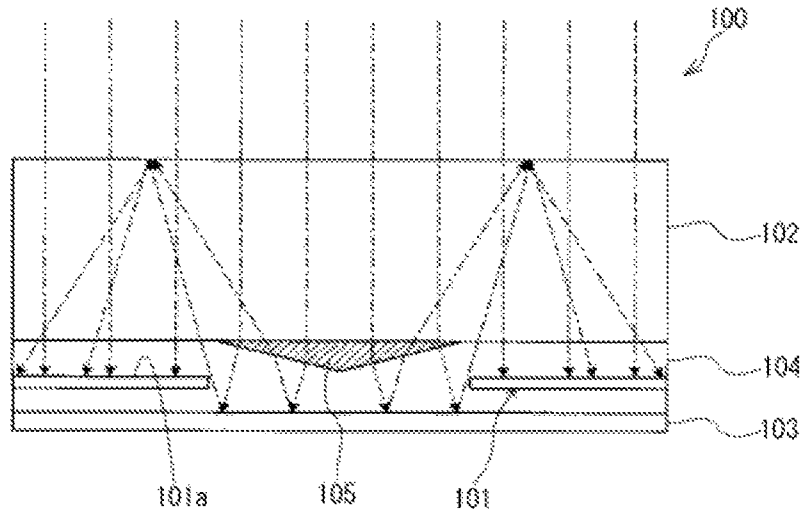

FIG. 9

1

SOLAR MODULE

CROSS-REFERENCE TO RELATED APPLICATIONS

This is a continuation of International Application PCT/JP2012/054894, with an international filing date of Feb. 28, 2012, filed by applicant, the disclosure of which is hereby incorporated by reference in its entirety.

FIELD OF THE INVENTION

The present invention relates to a solar module having a plurality of solar cells.

BACKGROUND

The solar module **100** shown in FIG. **9** is disclosed in Patent Document 1. The solar module **100** is provided with a plurality of solar cells **101**. A transparent substrate **102** is arranged on the light-receiving surface side of the solar cells **101**. A back sheet **103** is arranged on the back surface side of the solar cells **101**. A resin sealing layer **104** fills space between the back sheet **103** and the transparent substrate **102**. A low-refraction layer **105** having a refractive index lower than that of the resin sealing layer **104** is provided between the transparent substrate **102** and the resin sealing layer **104**. The low-refraction layer **105** protrudes towards the side of the back sheet **103**.

Patent Document 1 describes how power generating efficiency can be increased by providing a low-refraction layer **105** to direct light incident between adjacent solar cells **101** towards the light-receiving surfaces **101a** of the solar cells **101**.

CITED DOCUMENTS

Patent Documents

Patent Document 1: Laid-Open Patent Publication No. 2011-29273

SUMMARY

Problem Solved by the Invention

In recent years, there has been a desire for improved photoelectric conversion efficiency in solar modules.

In view of this situation, it is an object of the present invention to provide a solar module having improved photoelectric conversion efficiency.

Means of Solving the Problem

The solar module of the present invention is provided with a bifacial light-receiving solar cell, a transparent member, a weather-resistant member, and a bonding layer. The transparent member is arranged on the light-receiving surface side of the solar cells. The weather-resistant member is arranged on the back surface of the solar cells. The bonding layer is arranged between the transparent member and the weather-resistant member. The bonding layer includes at least two media having different refractive indices. Interfaces are formed by at least two media and positioned in a region unoccupied by the solar cells. The interfaces are configured such that at least some of the light that is incident on the

2

interfaces in a direction perpendicular to the solar module is guided to the back surface of the solar cell.

Effect of the Invention

The present invention is able to provide a solar module having improved photoelectric conversion efficiency.

BRIEF DESCRIPTION OF THE DRAWINGS

FIG. **1** is a schematic plan view of a solar module according to a first embodiment.

FIG. **2** is a schematic cross-sectional view from line II-II in FIG. **1**.

FIG. **3** is an exploded schematic cross-sectional view of the laminate used to create the solar module in the first embodiment.

FIG. **4** is a schematic cross-sectional view of a solar module according to a second embodiment.

FIG. **5** is a schematic cross-sectional view of a solar module according to a third embodiment.

FIG. **6** is an exploded schematic cross-sectional view of the laminate used to create the solar module in the third embodiment.

FIG. **7** is a schematic cross-sectional view of a solar module according to a fourth embodiment.

FIG. **8** is a schematic cross-sectional view of a solar module according to a fifth embodiment.

FIG. **9** is a schematic cross-sectional view of the solar module described in Patent Document 1.

DETAILED DESCRIPTION

The following is an explanation of an example of a preferred embodiment of the present invention. The following embodiments are merely examples. The present invention is not limited to the following embodiments in any way.

Further, in each of the drawings referenced in the embodiments, members having substantially the same function are denoted by the same symbols. The drawings referenced in the embodiments are also depicted schematically. The dimensional ratios of the objects depicted in the drawings may differ from those of the actual objects. The dimensional ratios of objects may also vary between drawings. The specific dimensional ratios of the objects should be determined with reference to the following explanation.

1st Embodiment

FIG. **1** is a schematic plan view of a solar module according to a first embodiment. FIG. **2** is a schematic cross-sectional view from line II-II in FIG. **1**.

The solar module **1** is provided with a plurality of solar cell strings **2**. The solar cell strings **2** are arranged at intervals from each other in one direction (the x direction). A solar cell string **2** has a plurality of solar cells **10**. In a solar cell string **2**, the solar cells **10** are arranged at intervals from each other in a direction (the y direction) perpendicular to the previous direction (x direction). Thus, the solar cells **10** in the solar module **1** are arranged in a matrix in both the x direction and the y direction. The solar cells **10** constituting the solar cell strings **2** are connected electrically by wiring material **11**. The wiring material **11** and the solar cells **10** can be bonded using a resin adhesive or solder.

Each solar cell **10** has a light-receiving surface **10a** and a back surface **10b**. Here, the main surface on which light L is directly incident is the light-receiving surface **10a**, and the other main surface is the back surface **10b**. However, each solar cell **10** can receive light and generate electricity on both

the light-receiving surface **10a** and the back surface **10b**. In other words, the solar cells **10** are bifacial light-receiving solar cells.

There are no particular restrictions on the solar cells **10** as long as they are bifacial light-receiving solar cells that receive light and generate electricity on both surfaces. The solar cells **10** can be single-crystal silicon solar cells, polycrystalline silicon solar cells, thin-film silicon solar cells, compound semiconductor solar cells, dye-sensitized solar cells, and organic thin-film solar cells.

A transparent member **15** is arranged on the light-receiving surface side (**z1** side) of the solar cells **10**. A weather-resistant member **14** is arranged on the back surface side (**z2** side) of the solar cells **10**. A bonding layer **13** is provided between the transparent member **15** and the weather-resistant member **14**. The solar cells **10** are sealed in a bonding layer **13**. The bonding layer **13** and the transparent member **15** allow light with a wavelength contributing to the generation of electricity in the solar cells **10** to pass through. The weather-resistant member **14** is resistant to the outside environment and is arranged on at least on the side opposite that of the solar cells **10**. However, the weather-resistant member **14** also reflects light with a wavelength contributing to the generation of electricity in the solar cells **10** on at least the side facing the solar cells **10**.

There are no particular restrictions on the constituent materials of the transparent member **15** and the weather-resistant member **14**. The transparent member **15** can be a glass plate or plastic plate. However, the weather-resistant member **14** has to have reflective properties on at least the side facing the solar cells **10**. For example, the weather-resistant member **14** can have a multilayer structure of weather-resistant film, reflective film, and light-transmitting film applied in order, respectively, from the side opposite that of the solar cells **10**. The weather-resistant member **14** can also have a multilayer structure consisting of weather-resistant film and a reflective layer. The reflective layer can be made of a reflective material such as a metal, metal alloy, or white resin film. An adhesive layer may be provided between the weather-resistant film and the reflective layer, and between the reflective layer and the light-transmitting film. The weather-resistant film, reflective layer and light-transmitting film may have a single-layer structure or a multilayer structure.

The bonding layer **13** has at least two media. More specifically, in the present embodiment, the bonding layer **13** has first through third media **13a**, **13b**, **13c**. The first medium **13a** is provided between the solar cells **10** and the transparent member **15** in the thickness direction (**z** direction) of the solar module **1**.

The second medium **13b** is provided between the solar cells **10** and the weather-resistant member **14**.

The third medium **13c** is arranged between adjacent solar cells **10** in the **x** direction, that is, in the region unoccupied by the solar cells **10**. The third medium **13c** is provided in the entire region between adjacent solar cells **10** in the **x** direction. Also, the third medium **13c** is arranged so as to extend in the **y** direction. In the present invention, the third medium **13c** may be provided in at least one portion of the region between adjacent solar cells **10** in the **x** direction.

The plane in which the surface of the third medium **13c** facing the transparent member **15** is located is closer to the plane in which the light-receiving surfaces **10a** of the solar cells **10** are located than the plane in which the surface of the transparent member **15** facing the solar cells **10** is located. In the example shown in FIG. 2, the surface of the third medium **13c** facing the transparent member **15** is substantially flush with the light-receiving surface **10a** of the solar cells **10**.

The third medium **13c** has an inclined surface that widens in the **x** direction towards the transparent member **15** and narrows towards the weather-resistant member **14**. The inclined surface extends from the back surface **10b** of the solar cells **10** towards the weather-resistant member **14** (**z2** side). In FIG. 2, the cross-sectional shape of the third medium **13c** in the **x** direction and the **z** direction is triangular with chamfered base angles.

The first medium **13a** and the third medium **13c** constitute a first interface **21** positioned between adjacent solar cells **10** in the **x** direction. The first interface **21** is substantially planar. The first interface **21** is substantially parallel to the light-receiving surface **10a** of the solar cells **10**.

The third medium **13c** and the second medium **13b** constitute a second interface **22** and a third interface **23** between adjacent solar cells **10** in the **x** direction. The second interface **22** is positioned on one side in the **x** direction (the **x1** side), and the third interface **23** is positioned on the other side in the **x** direction (the **x2** side). The second interface **22** extends (in the direction of the **x2** side) from the back surface **10b** away from the solar cells **10** and towards the side (**z2** side) with the weather-resistant member **14**. The end portion of the second interface **22** on the **x2** side reaches the weather-resistant member **14**. The third interface **23** extends (in the direction of the **x1** side) from the back surface **10b** away from the solar cells **10** and towards the side (**z2** side) with the weather-resistant member **14**. The end portion of the third interface **23** on the **x1** side reaches the weather-resistant member **14**. Both the second and the third interfaces **22**, **23** are substantially planar.

The solar module **1** satisfies the equation $n_{13b} > n_{13c}$, where n_{13a} is the refractive index of the first medium **13a**, n_{13b} is the refractive index of the second medium **13b**, and n_{13c} is the refractive index of the third medium **13c**. The difference between n_{13b} and n_{13c} ($n_{13b} - n_{13c}$) is preferably equal to or greater than 0.05, and even more preferably equal to or greater than 0.15. There is no particular limitation on the maximum value of the difference between n_{13b} and n_{13c} ($n_{13b} - n_{13c}$), but as an example 0.5 can be used. There is no particular limitation on n_{13a} , and it may be equal to or less than n_{13c} , between n_{13c} and n_{13b} , or equal to or greater than n_{13b} .

The value of the refractive index can be the value for any wavelength that can be absorbed by the solar cells **10**. For example, a value measured using the monochromatic light of sodium lamps (wavelength: 589.3 nm) can be used.

An ethylene-vinyl acetate (EVA) copolymer is a specific example of a material with a refractive index between 1.49 and 1.53. A polyethylene resin is a specific example of a material with a refractive index between 1.52 and 1.60. A polypropylene resin is a specific example of a material with a refractive index between 1.47 and 1.52. A polymethylmethacrylate resin is a specific example of a material with a refractive index between 1.48 and 1.52. A polyvinylbutyral resin is a specific example of a material with a refractive index between 1.46 and 1.50. A polydimethylsiloxane resin is a specific example of a material with a refractive index between 1.38 and 1.42. Glass is a specific example of a material with a refractive index between 1.43 and 2.1.

The constituent materials of the first through third media **13a-13c** can be selected from the materials mentioned above such that $n_{13b} > n_{13c}$.

In the present embodiment, $n_{13b} > n_{13c}$. Therefore, the incident light **L** perpendicular to the solar module **1** (in the **z** direction) is refracted at the second interface **22** towards the solar cells **10** (towards the **x1** side), reflected on the side with the weather-resistant member **14**, and incident on the back surface **10b** of the solar cells **10**. The light **L** is also refracted

at the third interface **23** towards the solar cells **10** (towards the x2 side), reflected on the side with the weather-resistant member **14**, and incident on the back surface **10b** of the solar cells **10**. In other words, in the present embodiment, second and third interfaces **22**, **23** are provided to direct some of the light L incident on the space between adjacent solar cells **10** towards the back surface **10b** of the solar cells **10**.

However, as described in Patent Document 1, the method used to allow light incident on the gap between adjacent solar cells in the x direction to contribute to the generation of power is to direct the light towards the light-receiving surface of the solar cells by refracting and reflecting the light incident on the gap between the solar cells. In order to direct the light towards the light-receiving surface of the solar cells, the light has to be reflected at least twice. As a result, the optical pass length of the light is lengthened in the bonding layer by the time the light incident on the gap between adjacent solar cells reaches the light-receiving surfaces of the solar cells. Light is absorbed by the bonding layer, and the solar cells experience significant light-collection loss. As a result, it is difficult to adequately improve the photoelectric conversion efficiency.

By contrast, in the present embodiment, second and third interfaces **22**, **23** are provided so that at least some of the light L incident on the interfaces **22**, **23** in the direction (z direction) perpendicular to the solar module is directed towards the back surface **10b**. Therefore, the optical pass length of the light L incident on the gap between adjacent solar cells **10** in the x direction can be shortened in the bonding layer **13** before the light reaches the solar cells **10**. Thus, light-collection loss experienced by the solar cells **10** due to light absorption by the bonding layer **13** can be reduced. As a result, a solar module **1** having improved photoelectric conversion efficiency can be realized.

When the ratio of n_{13b} to n_{13c} (n_{13b}/n_{13c}) is equal to or greater than 1.15, the refractive power of the second and third interfaces **22**, **23** relative to normal incident light L can be increased, and the angle of inclination of the second and third interfaces **22**, **23** relative to the x direction can be reduced. This can reduce the distance between the solar cells **10** and the weather-resistant member **14**. The result is a thinner solar module **1**. In order to further reduce the thickness of the solar module **1**, the ratio of n_{13b} to n_{13c} (n_{13b}/n_{13c}) is preferably equal to or greater than 1.20.

The first interface **21** is substantially parallel to the transparent member **15**. As a result, the normal incident light L is incident on the first interface **21** in a substantially perpendicular direction. As a result, the first interface **21** does not substantially refract the normal incident light L despite the refraction indices n_{13a} , n_{13b} .

The solar module **1** can be manufactured in the following manner. First, as shown in FIG. 3, the resin sheet **31** constituting the first medium **13a** is positioned on the transparent member **15**. Next, the solar cells strings **2** and the column-shaped member **32** constituting the third medium **13c** are positioned on the resin sheet **31**. Next, the resin sheet **33** constituting the second medium **13b** is positioned on the solar cell strings **2** and column-shaped member **32**. Finally, the weather-resistant member **14** is positioned on the resin sheet **33**. In this way, a stacked body **30** is created which includes the transparent member **15**, the resin sheet **31**, a plurality of solar cell strings **2**, a column-shaped member **32**, another resin sheet **33**, and a weather-resistant member **14**.

This stacked body **30** is heated and crimped in a reduced pressure atmosphere and laminated to complete the solar module **1**.

Here, the melt flow rate (MFR) of the column-shaped member **32** is lower than that of the resin sheets **31**, **33** at the

temperature experienced when the stacked body **30** is heated and crimped (for example, 150° C.). More specifically, the column-shaped member **32** has a higher melt point than the resin sheets **31**, **32**, and is not substantially deformed when heated and crimped. The column-shaped member **32**, for example, may be made of glass. In this way, a solar module **1** with a substantially triangular column-shaped third medium **13c** can be obtained.

Other preferred embodiments of the present invention will now be explained. In this explanation, members having substantially the same function as those in the first embodiment are referenced using the same reference numbers and further explanation of these members has been omitted.

2nd Embodiment

FIG. 4 is a schematic cross-sectional view of a solar module according to a second embodiment.

In the first embodiment, both the second interface **22** and the third interface **23** were substantially planar. However, the second interface **22** and the third interface **23** may also be curved. In the second embodiment, both the second interface **22** and the third interface **23** are curved so as to protrude towards the side with the transparent member **15** (the z1 side). The second interface **22** and the third interface **23** may also be curved so as to protrude towards the side with the weather-resistant member **14** (the z2 side). In these cases, as in the case of the first embodiment, the light L incident on the space between adjacent solar cells **10** in the x direction can be effectively directed towards the back surface **10b**. Therefore, improved photoelectric conversion efficiency can be obtained.

3rd Embodiment

FIG. 5 is a schematic cross-sectional view of a solar module according to a third embodiment.

In the third embodiment, a plurality of fourth media **13d** are provided in the x direction between the back surface **10b** of the solar cells **10** and the weather-resistant member **14** along with the second medium **13b** and the third medium **13c**. The fourth media **13d** are arranged between the back surface **10b** of the solar cells **10** and the weather-resistant member **14**. Each of the fourth media **13d** has a triangular column shape extending in the y direction. There are no particular restrictions on the refractive index n_{13d} of the fourth media **13d**. It may be the same as the refractive index n_{13b} of the second medium **13b**, greater than n_{13b} , or smaller than n_{13b} .

In the third embodiment, additional media are provided on the bonding layer to create additional interfaces. As in the case of the first embodiment, the light L incident on the space between adjacent solar cells **10** in the x direction can be effectively directed towards the back surface **10b**. Therefore, improved photoelectric conversion efficiency can be obtained.

The solar module in the third embodiment can be manufactured in the following manner. First, as in FIG. 6, the resin sheet **31** constituting the first medium **13a** is positioned on the transparent member **15**. Next, solar cell strings **2** are positioned on the resin sheet **31**. Next, the resin sheet **34** constituting the third medium **13c** and fourth media **13d** is positioned on the solar cell strings **2**. Next, the member **35** constituting the second medium **13b** is positioned on the resin sheet **34**. The member **35** has a low MFR when heated and crimped. Finally, the resin sheet **36** used to bond the member **35** to the weather-resistant member **14** is positioned on the member **35**, and the weather-resistant member **14** is positioned on the resin sheet **36** to complete the stacked body **30**. The stacked body **30** is heated and crimped in a reduced pressure atmosphere and laminated to complete the solar module in the third embodiment.

4th Embodiment

FIG. 7 is a schematic cross-sectional view of a solar module according to a fourth embodiment.

The solar module 4 in the fourth embodiment differs from the solar module 1 in the first embodiment only in that the third medium 13c is arranged on the transparent member 15 side of the back surface 10b of the solar cell 10.

In the fourth embodiment, as in the first embodiment, the third medium 13c is arranged at least in part between the first medium 13a and the second medium 13b, and between adjacent solar cells 10 in the x direction. In the example shown in FIG. 7, the third medium 13c is provided in the entire region between adjacent solar cells 10 in the x direction. The surface of the third medium 13c on the weather-resistant member 14 side (z2 side) is substantially flush with the back surface 10b of the solar cells 10. The third medium 13c also extends to the transparent member 15 side (z1 side) from the back surface of the solar cell 10. The cross-sectional shape of the third medium 13c in the x direction and the z direction is triangular with chamfered base angles.

In the fourth embodiment, the second medium 13b and the third medium 13c form a first interface 21 which is substantially parallel to the transparent member 15. The third medium 13c and the first medium 13a form second and third interfaces 22, 23, respectively, which are positioned between adjacent solar cells 10 in the x direction, that is, in the region unoccupied by the solar cells 10. The second interface 22 is positioned on one side (the x1 side) in the x direction, and the third interface 23 is positioned on the other side (the x2 side) in the x direction. The second interface 22 extends (in the direction of the x2 side) from the light-receiving surface 10a away from the solar cells 10 and towards the side (z1 side) with the transparent member 15. The end portion of the second interface 22 on the x2 side reaches the transparent member 15. The third interface 23 extends (in the direction of the x1 side) from the light-receiving surface 10a away from the solar cells 10 and towards the side (z1 side) with the transparent member 15. The end portion of the third interface 23 on the x1 side reaches the transparent member 15. Both the second and the third interfaces 22, 23 are substantially planar, but are not limited to this arrangement.

In the fourth embodiment, $n_{13c} < n_{13a}$. The difference between n_{13a} and n_{13c} ($n_{13a} - n_{13c}$) is preferably equal to or greater than 0.05, and even more preferably equal to or greater than 0.15. There is no particular limitation on the maximum value of the difference between n_{13a} and n_{13c} ($n_{13a} - n_{13c}$), but 0.5, for example, can be used. The ratio of n_{13a} to n_{13c} , (n_{13a}/n_{13c}) is equal to or greater than 1.05, and even more preferably equal to or greater than 1.15. There is no particular limitation on the upper limit of the ratio of n_{13a} and n_{13c} (n_{13a}/n_{13c}), but for example it can be 1.50. There is no particular limitation on n_{13b} , but it may be equal to or less than n_{13a} , between n_{13a} and n_{13c} , and equal or greater than n_{13c} .

In the present embodiment, both the second interface 22 and the third interface 23 extend away from the light-receiving surface 10a of the solar cells 10 towards the transparent member 15, and $n_{13c} < n_{13a}$. Therefore, the light L incident on the solar module 1 is refracted towards the solar cells 10 on the second interface 22 side (the x1 side), reflected on the weather-resistant member 14 side, and is incident on the back surface 10b of the solar cells 10. Also, the light L is refracted on the solar cell 10 side (x2 side), reflected on the weather-resistant member 14 side, and incident on the back surface 10b of the solar cells 10. In other words, in the present embodiment, a second interface 22 and a third interface 23 are provided such that at least some of the light L incident on the second and the third interfaces 22, 23 from the perpendicular

direction (z direction) relative to the solar module 1 is directed towards the back surface 10b.

Therefore, the solar module 4 in the fourth embodiment has excellent photoelectric conversion efficiency similar to that of the solar module 1 in the first embodiment.

When the ratio of n_{13a} to n_{13c} (n_{13a}/n_{13c}) is equal to or greater than 1.15, the refractive power of the second and third interfaces 22, 23 relative to normal incident light L can be increased, and the angle of inclination of the second and third interfaces 22, 23 relative to the x direction can be reduced. The result is a thinner solar module 4. In order to further reduce the thickness of the solar module 4, the ratio of n_{13a} to n_{13c} (n_{13a}/n_{13c}) is preferably equal to or greater than 1.20.

The fourth solar cell 4 can be completed by heating and crimping and laminating a stacked body similar to the stacked body 30 shown in FIG. 3 in a reduced pressure atmosphere. However, in the fourth solar cell 4, the orientation of the column-shaped member 32 does not differ by 180°.

5th Embodiment

FIG. 8 is a schematic cross-sectional view of a solar module according to a fifth embodiment.

The configuration of the solar module 5 in the fifth embodiment is similar to that of the first solar module 1 in the first embodiment except for the shape of the third medium 13c.

In the fifth solar module 5, the third medium 13c has a square column shape in which a pair of corners in the x direction has been chamfered. The third medium 13c and the second medium 13b constitute a second interface 22 and a third interface 23. The third medium 13c and the first medium 13a constitute a fourth interface 24 and fifth interface 25. The fourth interface 24 is positioned on one side in the x direction (the x1 side), and the fifth interface 25 is positioned on the other side in the x direction (the x2 side). The fourth interface 24 extends (in the direction of the x2 side) away from the solar cells 10 and towards the light-receiving surface (z1 side). The end portion of the fourth interface 24 on the x2 side reaches the transparent member 15. The fifth interface 25 extends (in the direction of the x1 side) away from the solar cells 10 and towards the light-receiving surface (z1 side). The end portion of the fifth interface 25 on the x1 side reaches the transparent member 15. Both the fourth and the fifth interfaces 24, 25 are substantially planar.

In the fifth embodiment, $n_{13b} > n_{13c} < n_{13a}$. The difference between n_{13a} and n_{13c} ($n_{13a} - n_{13c}$) is preferably equal to or greater than 0.05, and even more preferably equal to or greater than 0.15. There is no particular limitation on the maximum value of the difference between n_{13a} and n_{13c} , ($n_{13a} - n_{13c}$), but 0.5, for example, can be used. Similarly, the difference between n_{13b} and n_{13c} ($n_{13b} - n_{13c}$) is preferably equal to or greater than 0.05, and even more preferably equal to or greater than 0.15. There is no particular limitation on the maximum value of the difference between n_{13b} and n_{13c} ($n_{13b} - n_{13c}$), but 0.5, for example, can be used.

The ratio of n_{13a} to n_{13c} (n_{13a}/n_{13c}) is equal to or greater than 1.05, and preferably equal to or greater than 1.15. There is no particular limitation on the upper limit of the ratio of n_{13a} and n_{13c} (n_{13a}/n_{13c}), but for example it can be 1.50.

The ratio of n_{13b} to n_{13c} (n_{13b}/n_{13c}) is preferably equal to or greater than 1.05, and even more preferably equal to or greater than 1.15. There is no particular limitation on the upper limit of the ratio of n_{13b} and n_{13c} (n_{13b}/n_{13c}), but for example it can be 1.50.

In the fifth embodiment, the second through fifth interfaces 22-25 are provided to direct at least some of the light L incident on the fourth and fifth interfaces 24, 25 from the direction (z direction) perpendicular to the solar module 1 towards the back surface 10b. Therefore, the solar module 5 in

the fifth embodiment has excellent photoelectric conversion efficiency similar to that of the solar module **1** in the first embodiment.

When the ratio of n_{13c} to n_{13a} (n_{13c}/n_{13a}) is equal to or greater than 1.15 and the ratio of n_{13b} to n_{13c} (n_{13b}/n_{13c}) is equal to or greater than 1.20, the refractive power of the second through fifth interfaces **22-25** relative to normal incident light L can be increased, and the angle of inclination of the second through fifth interfaces **22-25** relative to the x direction can be reduced. The result is a thinner solar module **5**. In order to further reduce the thickness of the solar module **4**, the ratio of n_{13c} to n_{13a} (n_{13c}/n_{13a}) is preferably equal to or greater than 1.15, and the ratio of n_{13b} to n_{13c} (n_{13b}/n_{13c}) is preferably equal to or greater than 1.20.

The present invention includes many other embodiments not described herein. For example, interfaces may be provided between adjacent solar cells in a solar cell string **2** whose direction of array is the y direction in order to direct light incident on solar cells adjacent in the y direction towards the back surface of the solar cells. Also, the bonding layer **13** may include two media or four or more media. The planar shape of the solar cells **10** may also be a rectangular shape having four corners that have been chamfered or round chamfered. The solar cells **10** may also be back contact solar cells. Thus, the present invention includes many other embodiments not described herein. Therefore, the technical scope of the present invention is defined solely by the items specified in the claims.

1, 4, 5: Solar module

10: Solar cell

10a: Light-receiving surface

10b: Back surface

13: Bonding layer

13a: First medium

13b: Second medium

13c: Third medium

13d: Fourth medium

14: Weather-resistant member

15: Transparent member

21: First interface

22: Second interface

23: Third interface

24: Fourth interface

25: Fifth interface

What is claimed is:

1. A solar module comprising:

a bifacial light-receiving solar cell,

a transparent member that reflects light arranged on the light-receiving surface side of the solar cell,

a weather-resistant member arranged on the back surface side of the solar cell, and

a bonding layer arranged in a space between the transparent member and the weather-resistant member; wherein the bonding layer including at least two media with different refractive indices, interfaces are formed by at least two media and are positioned in a region unoccupied by the solar cells, and

the interfaces being configured such that at least some of the light that is incident on the interfaces in a direction perpendicular to the solar module is refracted at the interfaces towards the solar cells, reflected on the weather-resistant member, and guided to the back surface of the solar cells.

2. The solar module according to claim **1**, wherein the interface extends from the back surface of the solar cell away from the solar cell and towards the weather-resistant member; and the medium positioned on the weather-resistant member side of the interface has a refractive index that is higher than the refractive index of the medium positioned on the transparent member side of the interface.

3. The solar module according to claim **1**, wherein the interface extends from the light-receiving surface of the solar cell away from the solar cell and towards the transparent member; and the medium positioned on the weather-resistant member side of the interface has a refractive index that is lower than the refractive index of the medium positioned on the transparent member side of the interface.

4. The solar module according to claim **1**, wherein the interface includes a first interface extending from the back surface of the solar cell away from the solar cell and towards the weather-resistant member, and a second interface extending from the light-receiving surface of the solar cell away from the solar cell and towards the transparent member; the medium positioned on the weather-resistant member side of the first interface having a refractive index that is higher than the refractive index of the medium positioned on the transparent member side of the first interface, and

the medium positioned on the transparent member side of the second interface having a refractive index that is higher than the refractive index of the medium positioned on the weather-resistant member side of the second interface.

5. The solar module according to claim **1**, wherein the difference in the refractive indices of the two media constituting the interface is equal to or greater than 1.05.

* * * * *