

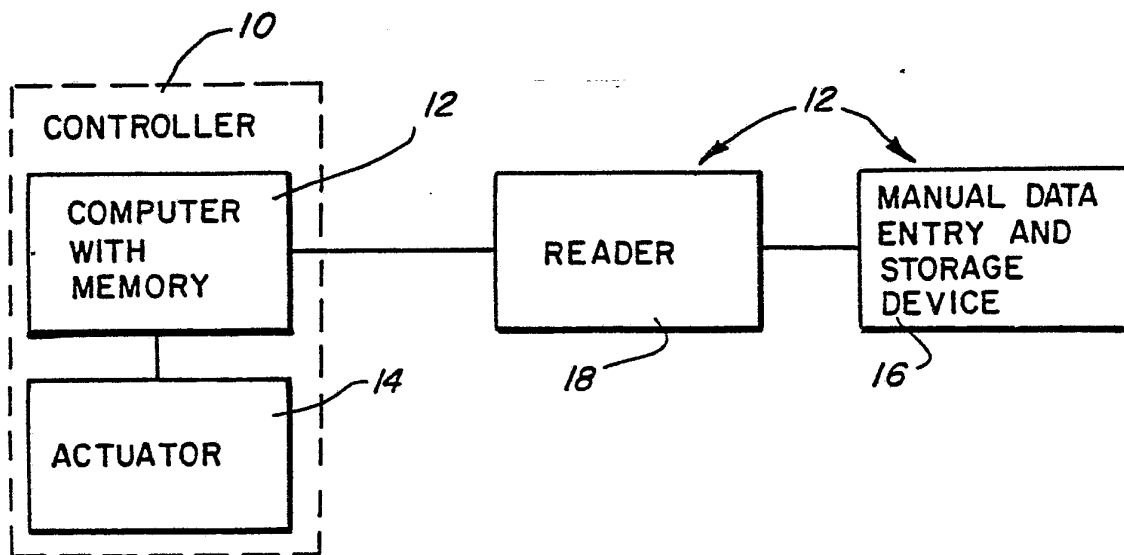

INTERNATIONAL APPLICATION PUBLISHED UNDER THE PATENT COOPERATION TREATY (PCT)

<p>(51) International Patent Classification <sup>3</sup> : <b>G06K 7/14</b></p>	<p><b>A1</b></p>	<p>(11) International Publication Number: <b>WO 83/ 04446</b> (43) International Publication Date: 22 December 1983 (22.12.83)</p>
<p>(21) International Application Number: PCT/US82/00796 (22) International Filing Date: 11 June 1982 (11.06.82)</p> <p>(71) Applicant (for all designated States except US): MA- NAGEMENT INVESTMENT &amp; TECHNOLOGY CO., LTD. [GB/HK]; Wah Ming Building, 15th Floor, 34, Wong Chuk Hang Road, Aberdeen (HK).</p> <p>(72) Inventors; and (75) Inventors/Applicants (for US only) : FIENE, Dale, E. [US/US]; 337 North Chestnut, Addison, IL 60601 (US). YUNG, Richard [GB/HK]; Management In- vestment &amp; Technology Co., Ltd., Wah Ming Build- ing, 15th Floor, 34, Wong Chuk Hang Road, Aberd- een (HK).</p> <p>(74) Agent: POTTHAST, James, W.; Three Illinois Center - Suite 1210, 303 East Wacker Drive, Chicago, IL 60601 (US).</p> <p>(81) Designated States: AT (European patent), BE (Euro- pean patent), CH (European patent), DE (European patent), FR (European patent), GB (European pa- tent), JP, LU (European patent), NL (European pa- tent), SE (European patent), US.</p>		<p><b>Published</b> <i>With international search report.</i></p>

(54) Title: MANUALLY PROGRAMMABLE COMPUTER DATA ENTRY AND STORAGE DEVICE AND METH-  
OD



(57) Abstract

Apparatus and method for easy manual programming of microprocessor or computer controlled equipment. In such equipment a need has arisen for simplified devices and techniques to enter data into the computer. A method is disclosed in which the data is visually readable by the user without the need of any reading or display equipment. This method is used in a combination of a computerized controller (10) having a memory (12) and an actuator (14) used with a reader (18) and a manual data entry and storage apparatus (16) for entering user selected data into the memory (12). The manual data entry and storage apparatus (16) includes a data entry base with a plurality of locations (20) for manual entry of machine readable user data (22, 24, 26, 28 and 30). Preferably durable data entry base material at the data locations (20) enables repeated alterations to the data. In a preferred form the manual data entry and storage device (16) comprises an elongated plastic strip with data locations (20) for receipt of photo-optically detectable pencil markings.

***FOR THE PURPOSES OF INFORMATION ONLY***

Codes used to identify States party to the PCT on the front pages of pamphlets publishing international applications under the PCT.

AT	Austria	LI	Liechtenstein
AU	Australia	LK	Sri Lanka
BE	Belgium	LU	Luxembourg
BR	Brazil	MC	Monaco
CF	Central African Republic	MG	Madagascar
CG	Congo	MR	Mauritania
CH	Switzerland	MW	Malawi
CM	Cameroon	NL	Netherlands
DE	Germany, Federal Republic of	NO	Norway
DK	Denmark	RO	Romania
FI	Finland	SE	Sweden
FR	France	SN	Senegal
GA	Gabon	SU	Soviet Union
GB	United Kingdom	TD	Chad
HU	Hungary	TG	Togo
JP	Japan	US	United States of America
KP	Democratic People's Republic of Korea		

-1-

MANUALLY PROGRAMMABLE COMPUTER DATA  
ENTRY AND STORAGE DEVICE AND METHOD

DESCRIPTION

BACKGROUND OF THE INVENTION

5 This invention relates generally to an apparatus  
and method for easy manual programming of microprocessor  
controlled or computer controlled equipment. As computers  
become more commonly used for a variety of functions, a  
need has arisen for simplified devices and techniques for  
entry of data into the computer. This is particularly  
true with respect to microprocessors and small or special  
purpose computers which are used to control various electro-  
mechanical devices. Known apparatus and methods used in  
10 larger commercial applications are less than satisfactory  
for use with the special purpose computers designed for  
consumer use.

15 Punched paper cards and tapes are often used for  
entering data into large general purpose computers. However,  
such cards or tapes generally require a large and expensive  
automatic tape or card punching machine operated from a  
keyboard, known as a key punch machine. These key punch  
machines punch in the card or tape a coded pattern of holes  
for each letter or function of the keyboard in the paper.  
20 While such codes can be visually read, the codes are  
sophisticated and only persons trained in the reading of  
such codes can do so. In fact, the codes are so difficult  
to read, card punch machines are often provided with a  
separate printer to print the letter with its associated  
25 punched code.

30



-2-

While the holes could be manually punched in the cards or tape with a simple hand tool, such as is done with computer cards used for voting, entering data on these cards or tapes in this manner requires a thorough  
5 knowledge of the code being used and is impractical.

Another disadvantage unique to punched cards or tapes, is that once the card or tape has been perforated it is not easily changed, if changeable at all. Each card is usable for only one particular set of data or instructions.

10 Magnetic tape and disc have also been used to store and enter data into computers. A principal advantage that they have over punched cards or tape is that they are erasable and reuseable. However, a magnetic tape or disc always requires a sophisticated tape recorder operated  
15 from a keyboard. Moreover, there is absolutely no possibility of visual reading data stored on the magnetic tape or disc as with punched card or tape. Reading of the tape or disc can only be done through use of the magnetic tape or disc player with a suitable visual display.

20 In retail stores and the like it is now known to encode price and inventory information in bar code form on item labels. These labels are read into a computer by a photo-optical reader maintained at a cash register terminal. Such labels, however, require precise machine printing of  
25 the bar codes according to exacting standards and, like punched tape, are also difficult to decipher.

It is also believed that input test data has been entered into a computer for scoring standardized tests by machine reading pencil markings made at selected data  
30 answer locations on the answer sheets.

#### SUMMARY OF THE INVENTION

35 The principal object of my invention is to provide a user of microprocessor, or computer controlled equipment, or controllers, a apparatus and method to easily manually program the controller to obtain the desired results from the equipment.



-3-

In keeping with this objective, the invention provides the combination of a controller having a computer with a memory and an actuator controlled by the computer in accordance with user selected data entered into the memory, and a manual data entry and storage apparatus for entering user selected data into the computer. The manual entry and storage apparatus includes a data entry and storage device having a plurality of locations for selective manual receipt of machine readable, user selected data manually enterable thereat, and means for machine reading the data of the data entry and storage device into the computer.

In a preferred embodiment, the data entry and storage device comprises an elongate member with a surface having a plurality of selected data entry locations for receipt of pencil marks or the like to designate selection of the data locations. The member is in the form of an elongate strip containing instructional information and identifying the association of the different data locations with particular data. After the data marks are entered on the strip with a pencil-like instrument, the user manually passes it through the reader which reads the selected data into the computer memory.

The device with the markings at the selected data entry locations is then preserved. Preferably it is kept with the controller, so that the user can visually read it at a later time to determine what was previously entered into the computer. If it is desired to enter a new set of data, the markings associated with the old data to be changed are erased, and new markings are made at the newly selected data locations. After reprogramming of the data entry and storage device is completed, it is again manually passed through the reader to enter the new set of data. Alternately, data is entered on another blank data entry and storage device which is then used to reprogram the computer.

However, preferably the data entry and storage device is reusable, and a further objective of this invention is to provide such a computer data entry and storage device which is manually reprogrammable, so that it may be used



repeatedly. In keeping with this objective, in a preferred embodiment, a data entry base is provided with a plurality of locations for the entry of machine readable data and endurable means at the locations manually alterable for repeated receipt of machine readable data manually entered at the locations. In one embodiment, the endurable means comprises an erasable surface which is markable with pencil marks and which is endurable to withstand repeated erasures and repeated marks. Other embodiments of the data entry and storage device include reusable simple hand operated mechanisms for repeatedly mechanically, magnetically or otherwise marking selected data locations.

Since the device provides durable means at the locations manually alterable for repeated receipt of machine readable data, the device is easily altered to correct inappropriate data or instructions. Furthermore, the device is easily manually reprogrammed to provide convenience to the user for updating his instructions to the controller, microprocessor or computer.

Yet another object of the invention is to provide a data entry and storage device for programming a controller in which the device contains visually readable instructions or designations to inform the user the manner of entering data onto it so that complicated codes do not have to be learned by the user in order to program the controller.

Still further object is to provide the above described method of using the data entry and storage device to program a microprocessor, a controller or other device.

#### BRIEF DESCRIPTION OF THE DRAWINGS

The foregoing objects, features and advantages will be discussed in greater detail, and other objects, features and advantages of the present invention will be made apparent in the following detailed description of the preferred embodiment of the invention, which is given with reference to the several views of drawings, in which:



-5-

Fig. 1 is a functional block diagram of a controller and manual data entry and storage apparatus of the present invention;

Fig. 2 is a fragmentary plan view of the data entry and storage device with data entered thereon;

Fig. 3 is a perspective view of a manually programmable thermostatic controller with a data entry and storage device being hand fed into its reader;

Fig. 4 is a fragmentary perspective view of another embodiment of the data entry and storage device;

Fig. 5 is a fragmentary plan view of yet another embodiment of the data entry and storage device;

Fig. 6 is a fragmentary, partially sectioned, perspective view of a further embodiment of the data entry and storage device;

Fig. 7 is a fragmentary plan view of still another embodiment of the data entry and storage device;

Fig. 8 is a fragmentary plan view of yet a further embodiment of the data entry and storage device;

Fig. 9 is still a further embodiment of the data entry and storage device;

Fig. 10 is a perspective view of another embodiment of a controller constructed in accordance with the present invention; and

Fig. 11 is a perspective view of still a further embodiment of a controller constructed in accordance with the present invention.

#### DETAILED DESCRIPTION

Referring to Fig. 1, a functional block diagram of the present invention is seen to comprise a controller 10 in combination with the manual data entry and storage apparatus 12. The controller 10 has a microprocessor or other computer 12 with a memory (not shown) and an actuator 14. The term computer used herein and in the claims shall mean not only a microprocessor or other computer of general



-6-

construction having a central processing unit, read only memory and a random access memory , but shall also include any programmable electronic device which may be specially designed to perform only certain special functions. Numerous  
5 data readers and microprocessors are well known, and neither the details of the reader nor the details of the computer and actuator form any part of the present invention and are therefore not described in detail.

However, briefly often the computer 12 will  
10 comprise a microprocessor with a central processing unit, or CPU. The memory includes a read only memory, or ROM, in which the basic computer programs are stored, and a random access memory, or RAM, within which user data is temporarily stored. The actuator includes suitable interface  
15 circuitry for producing output signals of sufficient magnitude and appropriate form to control selected devices connected therewith.

The computer controls the actuator 14 in accordance with its programs stored in the ROM, such as general instructions to turn on a furnace at a selected time of the day,  
20 and as specified by the user programmable data stored in the RAM which specifies the selected turn-on time.

The manual data entry and storage apparatus 12 comprises a manual data entry and storage device 16 and  
25 a reader 18. The manual data entry and storage device 16 manually receives data from a user, such as the time of day to change the temperature to a temperature selected by the user. This data is entered in a form readable by both the user and by photo-optical detectors, magnetic  
30 detectors, or any other suitable well known automatic data readers. After entry, the user passes the manual data entry and storage device 16 through the reader 18 which automatically reads the data stored thereon into the users portion of the computer emmory.

35 Preferably, for purposes of simplicity, the reader 18 is of the type which permits manual movement by the user of the device 16 through the reader. Alternately, it has



-7-

an apparatus for automatically feeding the device 16 past a read head within the reader 18.

Referring to Figs. 2 and 3, an exemplary embodiment of the present invention is shown in the form of a programmable, computer-controlled thermostat. As best seen in Fig. 2, a preferred embodiment of the manual data entry and storage device 16 comprises an elongate strip having a base, or body, 18 along which are serially provided a plurality of data entry locations 20 at which data is manually enterable by means of a graphite pencil or other suitable marker. The base 18 carries instructional and identifying information which designates the different data locations 20 as to the type of data and the value of the data associated with each of the locations. Instructional information, such as an arrow 17 showing the direction of movement for reading, is also provided.

In this particular example, the different types of data include time point, day of the week, temperature and time. For each of ten different time points, such as time point four indicated by a mark 22, the device 16 is programmed with the day, such as Saturday and Sunday indicated by a mark 24, temperature, as indicated by mark 26 and time, as indicated by mark 28 or mark 30. In the example shown in Fig. 2, the device specifies that for time point four on Saturday and Sunday, the controller should cause the temperature to go to 60° F., mark 26, at 12 A.M., mark 28. Alternately, the time of 2 P.M. could be indicated by mark 30.

A different device 16 is provided for each of the ten different time points. A program for a thermostatic control for a week which utilizes only five of the time points, might appear as follows:



35

-8-

	TIME POINT	DAY	TEMP.	TIME
	1	M T W TH F S SU	60°	12 midnight
	2	M T W TH F S SU	68°	5 A.M.
	3	M T W TH F	72°	6 A.M.
5	4	S SU	72°	8 A.M.
	5	M T W TH F	68°	10 P.M.

The various data locations preferably have durable, markable surfaces to which pencil or other markings are repeatedly adherable and erasable. In this way, a change or correction to the program can be made simply by erasing the appropriate marks on the device 16 and entering new marks at different data locations 20, as desired. In the form of applicant's invention shown in Fig. 2, the device 16 comprises a Mylar or other markable and durable, hand held plastic strip, and the various data locations are integrally formed with base 18. As will be described in greater detail, alternate forms of the manual data entry and storage device are contemplated.

Referring to Fig. 3, a thermostat controller is shown about to be programmed by means of strip 16 being manually passed through the slot 32 within which is located a photo-optical read head 34 of a reader 18. The controller also has other manual controls such as a fan control switch 36 and a mode selection switch 38. The mode selection switch 38 has different settings for heating, cooling, turning power off, time indication and for programming. A digital display 40 provides an indication of temperature and can be used to display other functions generated by the computer, such as time of day. A clock associated with display 40 indicates to the computer the time of day and the day of the week. The thermostat also has a thermocouple or other device for receiving current temperature data from the environment. This data is used to automatically inform the computer when a selected temperature or time has been reached.

As seen, the computer controlled thermostat of Fig 3 is programmed by simply manually sliding the manual



-9-

data entry and storage device 16 for each time point past the read head 34 by sliding it through the read slot 32.

The computer actuator and reader are all mounted within a housing 40, and the housing 40 is provided with a storage compartment 42 for purposes of storing the data entry and storage devices 16 for each of the ten different time points. The program which has been entered into the computer can thus simply be determined by removing the devices 16 from their storage compartment and visually examining them. If a change is desired in any aspect of the program, the manual data entry and storage device 16 associated with the particular time point which is desired to be altered is simply removed and alterations are made to the data stored by the device 16, as desired. Then the altered manual data entry and storage device 16 is again passed through the read slot 32 and past read head 34 to read the new data into the computer.

For simple programs, a single read head reading a single channel of data will often be adequate. However, as indicated in Fig. 2 by mark 30, in an alternate embodiment, multiple read heads are provided for a plurality of parallel channels. In this way, the length of the manual data entry and storage device 16 can be shortened and the density of the information contained thereon increased. If ten parallel channels were readable by ten read heads, then the entire program for all ten time points could be entered into the computer with a single pass of device 16 past all the read heads.

The coding is preferably binary digital, or bar code although other coding schemes including analog coding may be employed. The coding scheme is preferably asynchronous or, if a mechanical feeding device is provided for feeding the device 16 past the read head 34 at a controlled speed, the coding can be synchronous. Confirmation that the correct data were entered into the memory may be provided by a suitable comparator program which will compare the inputs from repeated passes past the read head 34 of the same device 16.



-10-

While the embodiment of the manual data entry and storage device 16 shown in Fig. 2 in which the data is entered with pencil marks and removed by erasure is preferred because of its simplicity and low cost, other  
5 embodiments are contemplated. In Fig. 4, an embodiment of the manual data entry and storage device 16 is shown in which the base 18 is provided with a reading surface 23 having a plurality of depressions or holes with each hole being associated with a different data location  
10 20. Instead of marking the data locations 20 with a pencil or the like, the locations are marked with a plug or other marker 25 which is inserted into and releasably held in the opening. The marker 25 is flush with the top surface of the base. Alternately, the location 20 is marked with  
15 a plug 27 which is raised above the surface 23 of base 18. The absence or presence of a plug 25 and 27 in a particular hole may be mechanically detected by the reader. Alternately, the marker 25 and 27 may comprise a different tone than surface 23 so as to be photo-optically detected, a magnetic  
20 element to be magnetically detected, or they may contain a plurality of data elements detectable by an ultraviolet scanner or the like. Raised plug marker 27, on the other hand, is intended to be mechanically detected by a mechanical reader.

25 Referring to Fig. 5, the base 18 is provided with a plurality of data locations 20 and means for mounting marker members 26 for slidable movement into or out of reading, or marking relationship with the data locations 20. These markers 29, likewise, are photo-optically detectable, mechanically detectable, magnetically detectable  
30 or otherwise detectable by the associated reader.

Referring to Fig. 6, yet another embodiment of the manual data entry and storage device 16 is shown in which the markers comprise push buttons 31 movably mounted  
35 within the data locations for movement into and out of marking relationship therewith. In the embodiment of Fig. 6, the push button markers 31 are mounted to leaf springs 33 which are flexibly movable between a lowered



-11-

position in which the marker lies substantially flush with or beneath the top surface 23 of base 18, and a raised position in which the marker 28 protrudes above the top surface 23. Again, the push button markers 28 may be  
5 machine detectable through any available technique, such as magnetically, photo-optically, capacitively, mechanically, inductively, etc.

Referring to Fig. 7, another embodiment is shown in which the markers comprise bits of tape 35 provided  
10 from a tape supply 37 which are adhered to the base 18 by adhesive or the like.

Referring to Fig. 8, in another embodiment, the markers comprise elements 39 containing a plurality of hook-like members 41 which are releasably attached  
15 to thread-like members located on the base 18 of device 16. Alternately, they comprise elements 43 having thread-like members 45 releasably attachable to hook-like members 47 carried by base 16.

Referring to Fig. 9, in yet a further embodiment,  
20 the markers are in the form of ferromagnetic elements 48 adhered to a magnetic base 18 or in the form of magnetic elements 50 adhered to a ferromagnetic base 18.

Referring to Fig. 10, in a further embodiment, the manual data entry and storage devices 16 are mounted  
25 for slidable movement past a reader 18 within a housing 52 which also contains the controller 10. The manual data entry and storage devices 16 are permanently mounted for slidable movement past the reader 18 from an extended position without the housing whereat manual access to  
30 them can be gained to change the data entered thereon. A separate read head associated with each device 16 is mounted within housing 52 in reading relationship therewith.

Referring to Fig. 11, in yet another embodiment, the manual data entry and storage devices 16 are mounted  
35 to a housing 54 to which is also mounted the controller 10 and a movably mounted reader 18. Instead of the manual data entry and storage devices 16 being moved past the reader, the devices 16 are held stationery for display and



-12-

entry of data, and the reader 18 is moved across the devices 16 to read the data therefrom.

5 While particular embodiments have been shown, it should be appreciated that many variations may be made thereto without departing from the scope of the invention, as defined in the claims. For instance, while only a thermostatic controller and other types of residential or building functions are shown, it is clear that the data entry and storage device is useful with many types  
10 of commercial microprocessor controllers, various locking and security mechanisms, computer toys, home entertainment controllers and a variety of other applications. For instance, the device 16 could be used as a manually reprogrammable key or security pass for an electronic lock.



-13-

CLAIMS

1. The combination of:

a controller having a computer with a memory and an actuator controlled by said computer in accordance with user selected data entered into said memory;

5 a manual data entry and storage apparatus for entering user selected data into said computer, including:

a data entry and storage device having a plurality of locations for selective manual receipt  
10 of machine readable user selected data manually entered thereat; and

means for machine reading the data of said data entry and storage device into said computer.

2. A data entry and storage apparatus in accordance with claim 1 including a housing for said reading means, said housing having means for releasably holding said data entry and storage device.

3. A data entry and storage apparatus in accordance with claim 1 including hand held data entering means for manually entering said data at said locations.

4. A data entry and storage apparatus in accordance with claim 1 including a housing for said reader said housing having means for releasably holding said data entering means.

25 5. A data entry and storage apparatus in accordance with claim 1 in which said reading means includes a read head and an automatic mechanical feeder device for receiving said data entry and storage device and moving it in data reading relationship with said machine read  
30 head.

6. A data entry and storage apparatus in accordance with claim 1 in which said data entry and storage device is hand held and said reading means includes means for reading the data of said device as it is manually moved  
35 in reading relationship therewith.

7. A data entry and storage apparatus in accordance with claim 1 including means for mounting said



-14-

reading means for movement in reading relationship with said data entry and storage device.

8. A data entry and storage apparatus in accordance with claim 1 including means for mounting said data entry base for movement to a position away from the reader where it is accessible for manual alteration thereto.

9. A data entry and storage apparatus in accordance with claim 1 including  
a frame,  
a plurality of data entry and storage devices,  
means for mounting said plurality of data entry and storage devices to the frame, and  
means for mounting at least a portion of the reading means to the frame.

10. A data entry and storage apparatus in accordance with claim 1 in which said reading means is a synchronous reader.

11. A data entry and storage apparatus in accordance with claim 1 in which said reading means is an asynchronous reader.

12. A data entry and storage apparatus in accordance with claim 1 in which said data entry and storage device is hand sized.

13. A data entry and storage device in accordance with claim 1 in which said reading means is a digital reader.

14. A data entry and storage apparatus in accordance with claim 1 in which said reading means is a binary code reader.

15. A manually reprogrammable computer data entry and storage device in accordance with claim 1 in which said reading means is an analog reader.

16. A data entry and storage apparatus in accordance with claim 1 in which said data entry and storage device is manually reprogrammable for manual removal of formerly entered data and the manual addition of new data.



17. A data entry and storage apparatus in accordance with claim 1 in which said data entry and storage device comprises a base having a plurality of data locations at which data is manually removeable and enterable.

5 18. A data entry and storage apparatus in accordance with claim 1 in which said data is relatively enterable at said data locations by marking said locations with a machine detectable marker.

10 19. A data entry and storage apparatus in accordance with claim 1 in which said marker is a visually detectable marker and said reader is a photo optical reader.

15 20. A data entry and storage apparatus in accordance with claim 1 in which said data locations have surfaces markable by means of manual deposition of material adhered to the surface.

21. A data entry and storage apparatus in accordance with claim 1 in which said mark is visually detectable.

20 22. A data entry and storage apparatus in accordance with claim 1 in which said mark is erasable.

25 23. A data entry and storage apparatus in accordance with claim 1 in which said mark comprises a material manually deposited at selected locations, and said mark is erased by removal of said material from the location.

24. A data entry and storage apparatus in accordance with claim 1 in which said mark is removeable by

30

35



-16-

manually rubbing it from the surface at said data location.

25. A data entry and storage apparatus in accordance with claim 1 in which said mark is mechanically detectable and said reading means is a mechanical sensor.

26. A data entry and storage apparatus in accordance with claim 1 in which said mark is magnetic and said reading means is a magnetic sensor.

27. A manually reprogrammable computer data entry and storage device, comprising:

a data entry base having a plurality of locations for the entry of machine readable data; and endurable means at said locations manually alterable for repeated receipt of machine readable data manually entered at said locations.

28. A manually reprogrammable computer data entry and storage device in accordance with claim 27 in which said data entry base is hand held.

29. a manually reprogrammable computer data entry and storage device in accordance with claim 28 in which said data entry base is a flexible strip.

30. A manually reprogrammable computer data entry and storage device in accordance with claim 27 in which said data entry base is a plate-like member.

31. A manually reprogrammable computer data entry and storage device in accordance with claim 27 in which said data entry base is rigid.

32. A manually reprogrammable computer data entry and storage device in accordance with claim 27 in which said data entry base includes means at one of said locations for visually designating it as being associated with a particular kind of information.

33. A manually reprogrammable computer data entry and storage device in accordance with claim 27 in which said machine readable data is in a digital form.



-17-

34. A manually reprogrammable computer data entry and storage device in accordance with claim 27 in which said machine readable data is in a binary form.

5 35. A manually reprogrammable computer data entry and storage device in accordance with claim 27 in which said machine readable data is in analog form.

10 36. A manually reprogrammable computer data entry and storage device in accordance with claim 27 in which said durable means is a hand erasable surface sufficiently durable for repetitive receipt and removable of machine readable marking material without substantial degradation of said surface.

15 37. A manually reprogrammable computer data entry and storage device in accordance with claim 27, in which said durable means includes an opening defined by said data entry base.

20 38. A manually reprogrammable data entry and storage device in accordance with claim 37 in which said opening includes means for releasable, repetitive receipt and removal of a mating plug member.

25 39. A manually reprogrammable data entry and storage device in accordance with claim 37 in which said opening is a slot adapted for repetitive receipt of insert member and removal of the same without substantial permanent distortion of said slot.

30 40. A manually reprogrammable data entry and storage device in accordance with claim 1 in which said durable means has a generally hard, smooth surface for repetitive receipt and removal of a machine readable marking material adherable thereto without substantial permanent deterioration of said surface.

35 41. A manually reprogrammable data entry and storage device in accordance with claim 40 in which said generally hard smooth surface is made from plastic.

42. A manually reprogrammable data entry and storage device of claim 40 in combination with a source of said marking material.



-18-

43. A manually reprogrammable computer data entry and storage device in accordance with claim 27 in which said durable means includes a plurality of connectors for releasable connection with machine detectable elements.

44. A manually reprogrammable computer data entry and storage device in accordance with claim 43 in which said connectors comprise interlocking hair-like thread members of releasable engagement with said hook members or a plurality of hood members for releasable engagement with thread-like members.

45. A manually reprogrammable computer data entry and storage device in accordance with claim 27 in which said durable surface is manually, magnetically alterable for receipt of magnetically detectable data.

46. A manually reprogrammable data entry and storage device in accordance with claim 45 in combination with a magnetic marker, and means for releasably adhering said magnetic marker to said surface.

47. A manually reprogrammable data entry and storage device in accordance with claim 27 in which said durable means is a magnetizable member.

48. A manually reprogrammable data entry and storage device in accordance with claim 47 in combination with a marker releasable attached to said member by mutual magnetic attraction therewith.

49. A manually reprogrammable computer data entry and storage device in accordance with claim 27 in which said durable means includes a machine detectable marker member slideably mounted to said base for movement into and out of engagement with one of said data entry locations

50. A manually reprogrammable computer data entry and storage device in accordance with claim 49 in which said marker is hand movable.



-19-

51. A manually reprogrammable computer data entry and storage device in accordance with claim 50 in which said marker element is mounted to said base at said data location for slideable movement into and out of a machine readable position at said data locations.

52. A manually reprogrammable computer data entry and storage device in accordance with claim 49 in which said base has a selected direction of relative movement during reading and said marker is mounted for movement in a direction non-parallel thereto.

53. A manually reprogrammable computer data entry and storage device in accordance with claim 52 in which said marker comprises a slideably mounted push button.

54. A manually reprogrammable computer data entry and storage device in accordance with claim 27 in which said data entry base comprises a hand held strip member and said erasable means at said data entry locations have erasable, visually markable surfaces for receipt of photo-optically detectable data marks.

55. A manually reprogrammable computer data entry and storage device in accordance with claim 54 in which said data entry locations are serially

56. A manually reprogrammable computer data entry and storage device in accordance with claim 54 in which said data base carries means visually detectable for permanently uniquely identifying different ones of data entry locations as being associated with data for the selection of different data for entry and storage.

57. A manually reprogrammable computer data entry and storage device in accordance with claim 54 in which said data entry locations are arranged serially in a plurality of parallel rows.



-20-

58. A manually reprogrammable computer data entry and storage device in accordance with claim 54 in which hand held member is an elongate strip.

5 59. A manually reprogrammable computer data entry and storage device in accordance with claim 58 in which data entry locations are arranged seriatim along the length of the elongate strip.

10 60. A manually reprogrammable computer data entry and storage device in accordance with claim 58 in which said data entry locations are located adjacent an edge of said strip.

15 61. A manually reprogrammable computer data entry and storage device in accordance with claim 58 in which said data entry locations have data entered thereon in the form of eraseable markings on at least one of said data entry location surfaces.

20 62. A manually reprogrammable computer data entry and storage device in accordance with claim 27 in which said data is arranged thereby in the form of an eraseable marking on at least one of said data entry location surfaces.

25 63. A manually reprogrammable computer data entry and storage device in accordance with claim 62 in which said marking is made from a graphite-like material.

64. A manually reprogrammable computer data entry and storage device in accordance with claim 27 in which said data is manually entered by means of a pencil-like device.

30 65. A manually reprogrammable computer data entry and storage device in accordance with claim 27 in which machine readable data entered at said locations is manually removeable.

35 66. A manually reprogrammable computer data entry and storage device in accordance with claim 65 in which said data is in the form of a marking removeable by rubbing the marking off of a surface of said durable means.



-21-

67. A manually reprogrammable computer data entry and storage device in accordance with claim 27 in combination with a computer memory and means for reading data manually entered at said data entry locations into said computer memory.

68. A manually reprogrammable computer data entry and storage device in accordance with claim 67 in which said reading means has means for reading said data into the computer memory as the data entry base reader is manually moved relative to each other in reading relationship.

69. A manually reprogrammable computer data entry and storage device in accordance with claim 68 in which said data entry base is hand held and said reading means reads the data thereon as the data base is manually moved through the reader.



-22-

70. An apparatus for entering data into a controller by means of a reader for automatically reading said apparatus, comprising:

5 a data entry base having a plurality of selectable data locations respectively associated with different items of control data;

means carried by said data entry base for visually indicating to a user the association of said data locations with said items of control data associated therewith; and

10 means at said locations for receipt of handwritten visually detectable marks thereon detectable by said reader to indicate selection of the data locations.

71. The apparatus of claim 70 in which said data locations comprise a hand writable surface for receipt of  
15 pencil-like marks.

72. The apparatus of claim 70 in which said data locations are located on said data base at positions thereon accessible to a read head of said reader as the base is moved relative thereto in a single scanning motion.

20 73. The apparatus of claim 72 in which said data locations are seriatim.

74. The apparatus of claim 70 in which said base carries means for visually indicating the appropriate direction of movement of the apparatus for reading by said  
25 reader.

75. The apparatus of claim 70 in which said base carries means for visually indicating to the user the type of control data associated with different control functions.

30 76. The apparatus of claim 70 in which said base comprises an elongate paper-like strip.

77. The apparatus of claim 70 in which said base has a handle portion thereof spaced from the data locations for holding the apparatus as it is moved in reading relationship with the reader.

35



-23-

78. A method of using the apparatus of claim 70 to enter user data into a controller having a reader, comprising the steps of:

5                   handwriting marks at selected ones of said data locations; and

                  moving said apparatus past the reader in reading relationship therewith to enter the data thereon into the controller.

79. The method of claim 78 in which the step of  
10 moving said apparatus past the reader is performed manually.

80. The method of claim 78 including the steps of altering the means;

                  altering the visually detectable marks to change the control data carried by said apparatus to new data; and  
15                   again moving the apparatus past the reader to enter the new data into the controller.

81. The method of claim 80 in which said step of altering is performed by erasing the marks at selected ones of said data locations.

20                   82. The method of claim 80 in which said step of altering is performed by manually adding additional marks to selected data locations not previously marked.

83. The method of claim 80 including the step of storing the apparatus in close proximity with the  
25 reader after the control data thereof has been read into the controller.

84. A method of entering user data into a controller through use of an automatic reader, comprising the steps of:

30                   manually entering reader detectable control data codes directly onto a data entry and storage device; and

                  moving said data entry and storage device and reader relative to one another in reading relationship to read the data entered onto the data entry and storage device into the controller.

35                   85. The method of claim 84 in which the step of entering data onto said device is performed by manually making reader detectable marks at selected data locations carried thereby.



-24-

86. The method of claim 85 in which the step of making said marks is performed by manually marking said data location with a pencil-like apparatus.

87. The method of claim 85 in which said step of marking said data locations is by attaching a marking element to the data location.

88. The method of claim 87 in which said marking element is magnetically detachable and said reader is a magnetic reader.

89. The method of claim 87 in which said marking element is photo-optically detachable and said reader is a photo-optical reader.

90. The method of claim 87 including the step of movably mounting said marking element to said device, and in which step of marking is performed by manually moving said marking element into marking relationship with said data locations.

91. The method of claim 84 including the steps of: altering the control data stored on said data entry device; and again moving the device and reader relative to one another to enter the altered control data into the controller.

92. The method of claim 91 in which said step of altering is performed by removing the marks from selected ones of the data locations.

93. The method of claim 92 in which said step of removing is performed by erasing the marks.

94. The method of claim 91 in which said step of altering is performed by marking previously unmarked data locations.

35



FIG. 1

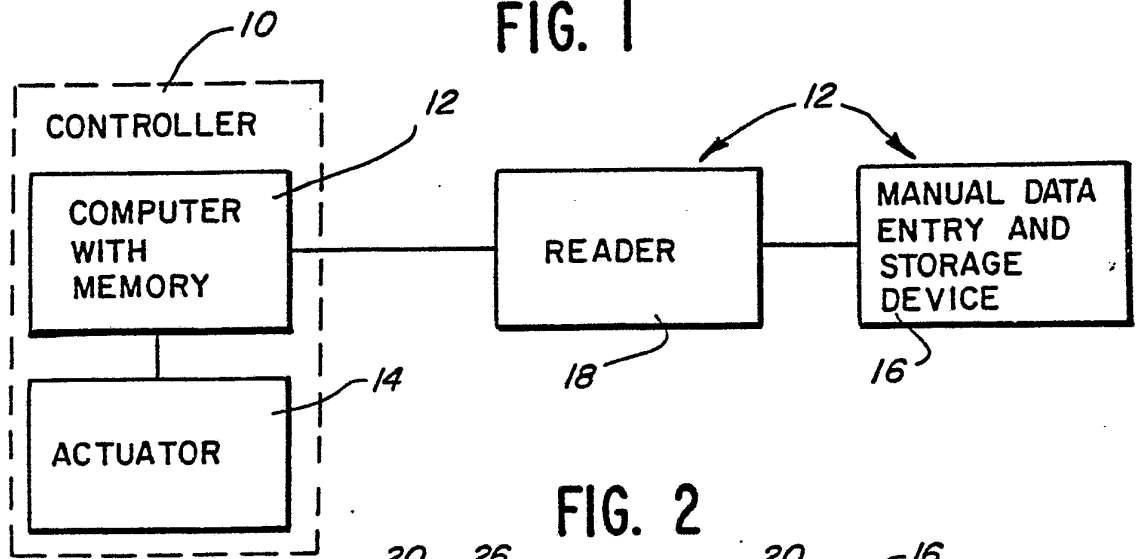

FIG. 2

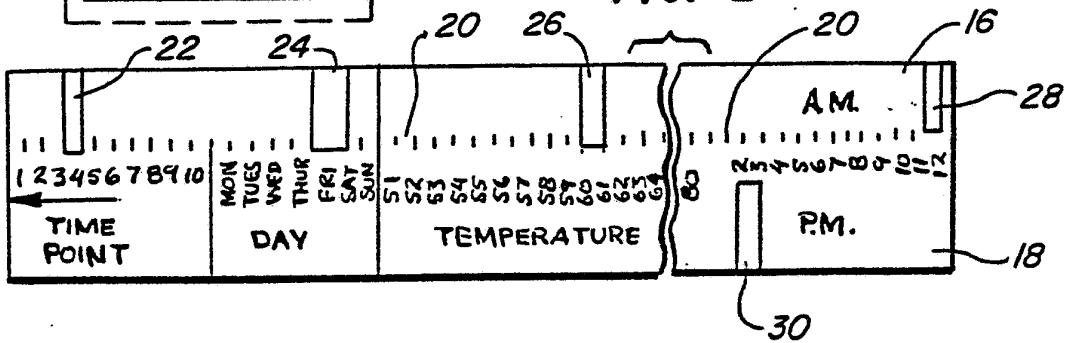
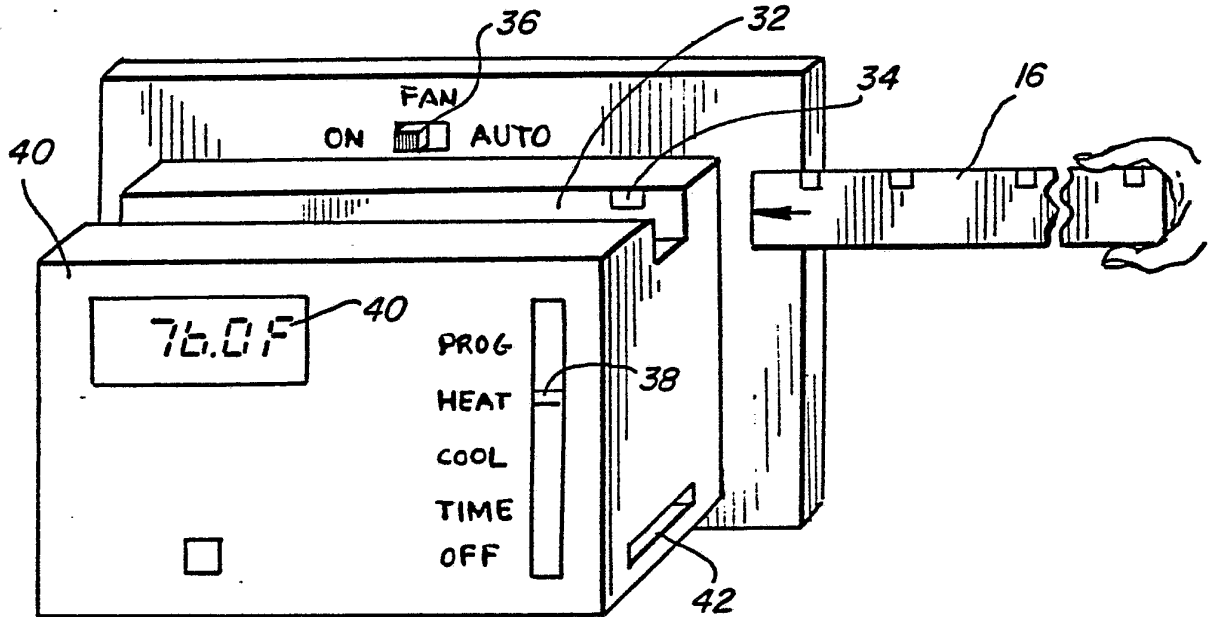

FIG. 3



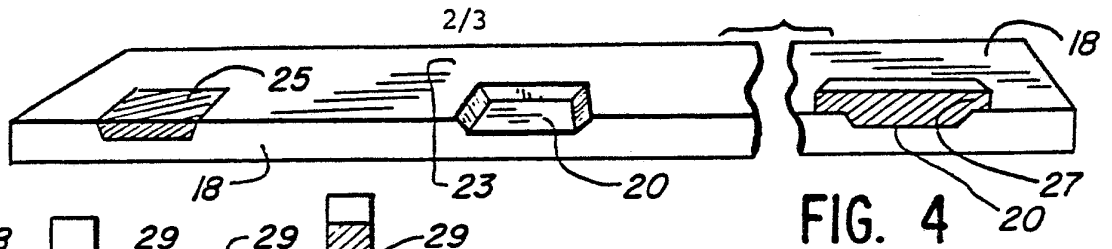

FIG. 4

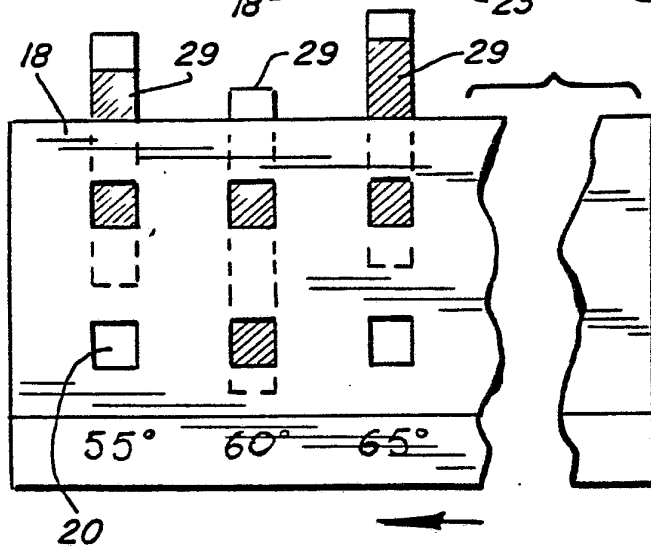

FIG. 5

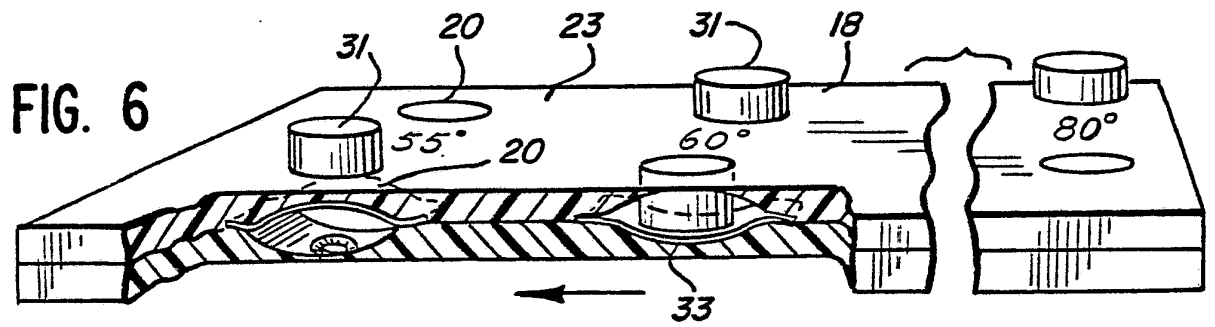

FIG. 6

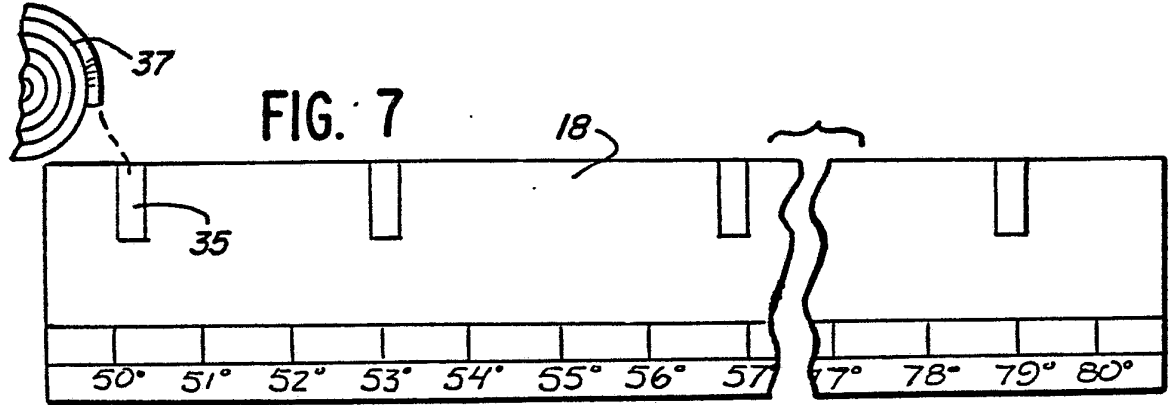

FIG. 7

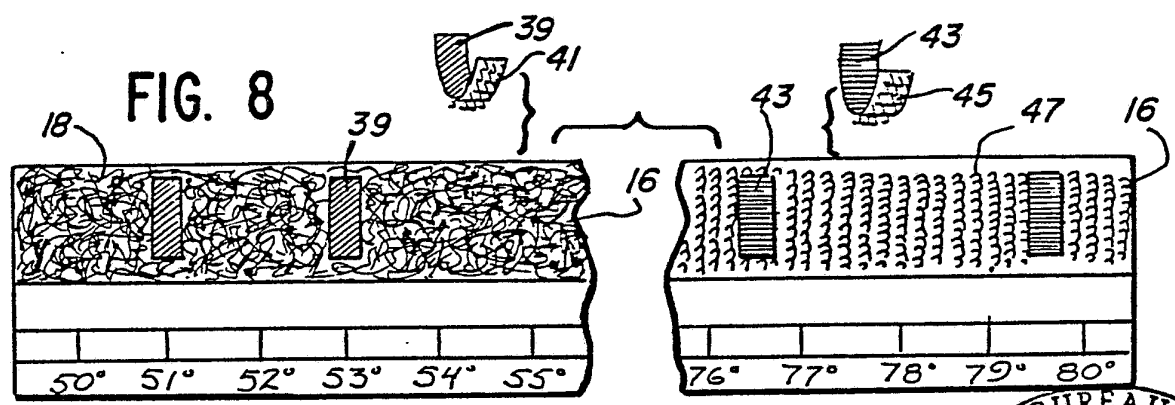

FIG. 8

SUBSTITUTE SHEET



3/3

FIG. 9

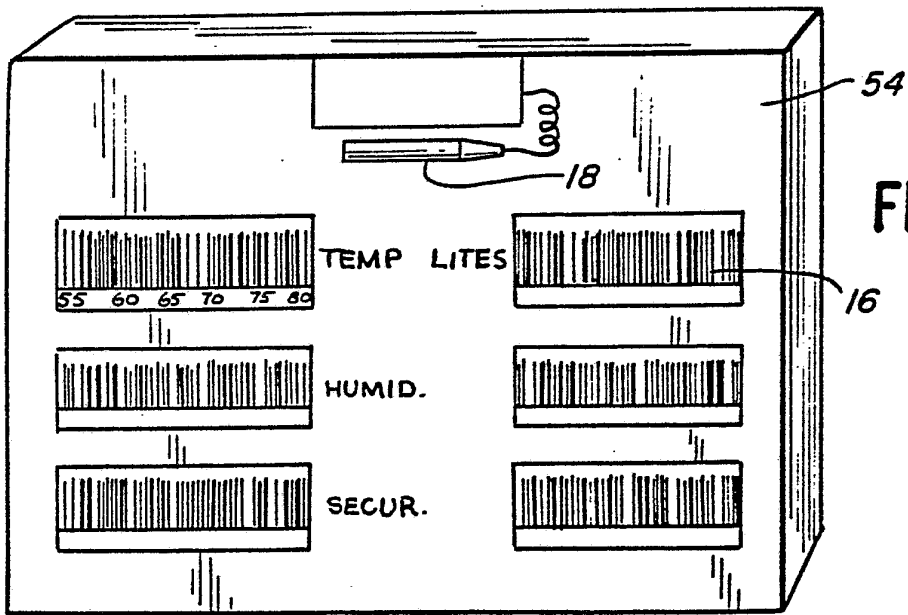
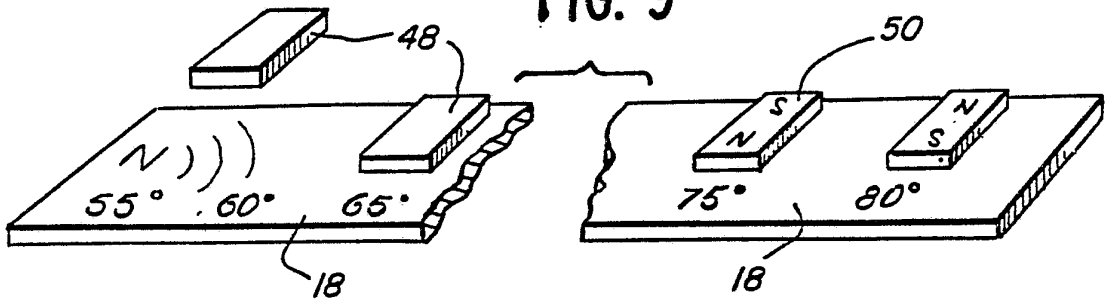

FIG. 11

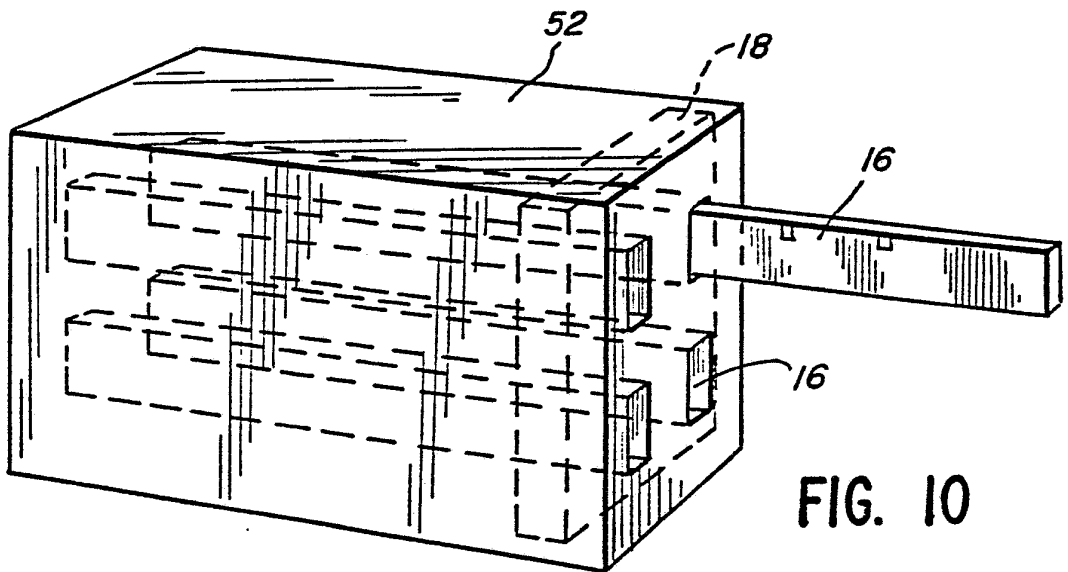

FIG. 10

# INTERNATIONAL SEARCH REPORT

International Application No

PCT/US82/00796

<b>I. CLASSIFICATION OF SUBJECT MATTER</b> (if several classification symbols apply, indicate all) <sup>2</sup>		
According to International Patent Classification (IPC) or to both National Classification and IPC		
INT. CL 3 G06K7/14,		
U.S. CL 235/375, 454, 449		
<b>II. FIELDS SEARCHED</b>		
Minimum Documentation Searched <sup>4</sup>		
Classification System	Classification Symbols	
U.S.	235/375, 454, 449	
Documentation Searched other than Minimum Documentation to the Extent that such Documents are Included in the Fields Searched <sup>5</sup>		
<b>III. DOCUMENTS CONSIDERED TO BE RELEVANT</b> <sup>14</sup>		
Category <sup>6</sup>	Citation of Document, <sup>16</sup> with indication, where appropriate, of the relevant passages <sup>17</sup>	Relevant to Claim No. <sup>18</sup>
X	U.S., A, 4,117,975, Published 3 October 1978, Gunn	1-5, 7, 9, 10, 12-14, 32
Y		6, 8, 11, 15-31, 33-94
X	N, Electronics, issued 5 January 1978, Vol. 51 No. 1, Pencil Programs 10-Channel Sequencer, Pages 263, 264	1-5, 7, 9, 10, 12-14, 32
Y		6, 8, 11, 15-31, 33-94
X	U.S., A, 3,284,929, Published 15 November 1966, Azure	1-5, 32, -- 6-31, 33-94
Y		
X	U.S., A, 3,722,111, Published 27 March 1973, Georges	1-5, 32 6-31, 33-94
Y		
X	U.S., A, 3,986,001, Published 12 October 1976, Saito	1-5, 32 6-31, 33-94
Y		
<p><sup>15</sup> * Special categories of cited documents:</p> <p>"A" document defining the general state of the art which is not considered to be of particular relevance</p> <p>"E" earlier document but published on or after the international filing date</p> <p>"L" document which may throw doubts on priority claim(s) or which is cited to establish the publication date of another citation or other special reason (as specified)</p> <p>"O" document referring to an oral disclosure, use, exhibition or other means</p> <p>"P" document published prior to the international filing date but later than the priority date claimed</p> <p>"T" later document published after the international filing date or priority date and not in conflict with the application but cited to understand the principle or theory underlying the invention</p> <p>"X" document of particular relevance; the claimed invention cannot be considered novel or cannot be considered to involve an inventive step</p> <p>"Y" document of particular relevance; the claimed invention cannot be considered to involve an inventive step when the document is combined with one or more other such documents, such combination being obvious to a person skilled in the art.</p> <p>"g" document member of the same patent family</p>		
<b>IV. CERTIFICATION</b>		
Date of the Actual Completion of the International Search <sup>3</sup>	Date of Mailing of this International Search Report <sup>3</sup>	
04 OCT 1982	05 OCT 1982	
International Searching Authority <sup>1</sup>	Signature of Authorized Officer <sup>20</sup>	
ISA/US	Robert Lev	

## III. DOCUMENTS CONSIDERED TO BE RELEVANT (CONTINUED FROM THE SECOND SHEET)

Category *	Citation of Document, <sup>16</sup> with indication, where appropriate, of the relevant passages <sup>17</sup>	Relevant to Claim No <sup>18</sup>
X Y	U.S., A, 3,787,660, Published 22 January 1974, Meyers et al.	1-5,32 6-31,33- 94
A	N, IBM Technical Disclosure Bulletin, Vol. 2, No. 6, issued 6 April, 1960 Scientific Message Exchange, by J. E. Bartlet, Page 29	
A	U.S., A, 2,941,717, Published 21 June 1960, Gould et al., Fig. 10	
A	N, IBM Technical Disclosure Bulletin, Vol. 5, No. 12, issued 12 May, 1963, Ferromagnetic Memory Readout, by R. E. Braun, Pages 46, 47	
A	U.S., A, 3,648,024, Published 7 March 1972, Schroder et al.	
A	U.S.,A, 3,317,715, Published 2 May 1967, Talbot et al.	