

(19) World Intellectual Property  
Organization  
International Bureau



(43) International Publication Date  
19 February 2004 (19.02.2004)

PCT

(10) International Publication Number  
WO 2004/014168 A2

- (51) International Patent Classification<sup>7</sup>: A42B
- (21) International Application Number: PCT/US2003/022501
- (22) International Filing Date: 8 August 2003 (08.08.2003)
- (25) Filing Language: English
- (26) Publication Language: English
- (30) Priority Data:
- |            |                               |    |
|------------|-------------------------------|----|
| 60/401,758 | 8 August 2002 (08.08.2002)    | US |
| 60/429,064 | 26 November 2002 (26.11.2002) | US |
| 60/474,924 | 3 June 2003 (03.06.2003)      | US |
- (81) Designated States (*national*): AE, AG, AL, AM, AT, AU, AZ, BA, BB, BG, BR, BY, BZ, CA, CH, CN, CO, CR, CU, CZ, DE, DK, DM, DZ, EC, EE, ES, FI, GB, GD, GE, GH, GM, HR, HU, ID, IL, IN, IS, JP, KE, KG, KP, KR, KZ, LC, LK, LR, LS, LT, LU, LV, MA, MD, MG, MK, MN, MW, MX, MZ, NI, NO, NZ, OM, PG, PH, PL, PT, RO, RU, SC, SD, SE, SG, SK, SL, SY, TJ, TM, TN, TR, TT, TZ, UA, UG, US, UZ, VC, VN, YU, ZA, ZM, ZW.
- (84) Designated States (*regional*): ARIPO patent (GH, GM, KE, LS, MW, MZ, SD, SL, SZ, TZ, UG, ZM, ZW), Eurasian patent (AM, AZ, BY, KG, KZ, MD, RU, TJ, TM), European patent (AT, BE, BG, CH, CY, CZ, DE, DK, EE, ES, FI, FR, GB, GR, HU, IE, IT, LU, MC, NL, PT, RO, SE, SI, SK, TR), OAPI patent (BF, BJ, CF, CG, CI, CM, GA, GN, GQ, GW, ML, MR, NE, SN, TD, TG).

- (71) Applicant and  
(72) Inventor: SCHNEIDER, Marc, S. [US/US]; 16620 Bobcat Court, Fort Myers, FL 33908 (US).
- (74) Agents: KASPER, Alan, J. et al.; Sughrue Mion, PLLC, 2100 Pennsylvania Ave., N.W., Suite 800, Washington, DC 20037-3213 (US).

Published:  
— without international search report and to be republished upon receipt of that report

For two-letter codes and other abbreviations, refer to the "Guidance Notes on Codes and Abbreviations" appearing at the beginning of each regular issue of the PCT Gazette.

(54) Title: ENERGY ABSORBING SPORTS HELMET

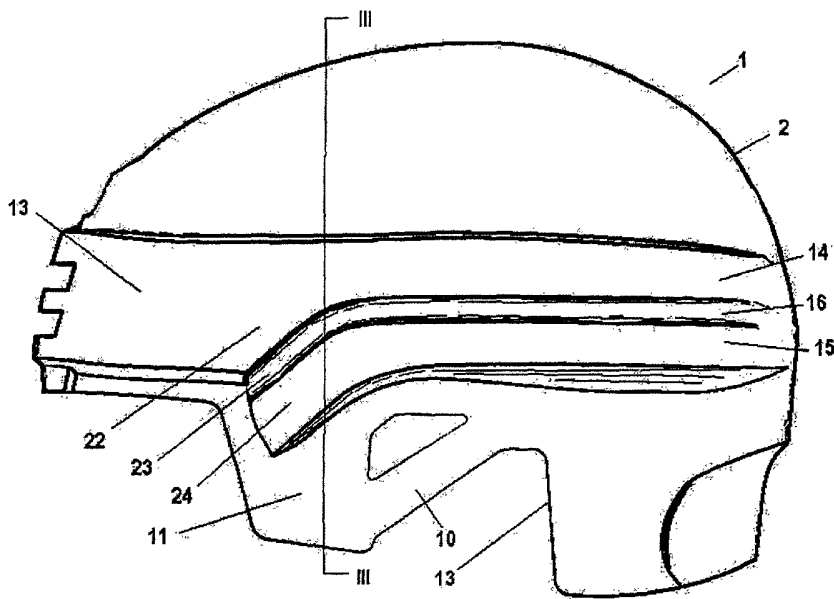

(57) Abstract: Slow recovery viscoelastic polyurethane foam with a surface impregnation of silicone, coupled with a rigid helmet shell, is used for athletic headgear. The helmet shell should have a rigid construct to provide dispersion of impact energy, absorbing at least thirty percent of the impact energy delivered to the helmet shell. The slow recovery viscoelastic polyurethane foam has unique characteristics making it suitable for use as an energy absorbing liner for athletic headgear. The energy absorbing liner can be made with varying thickness and size, so retail establishments can custom fit a helmet to a particular customer.

WO 2004/014168 A2

**ENERGY ABSORBING SPORTS HELMET**CROSS-REFERENCES TO RELATED APPLICATIONS

[0001] This application is an application filed under 35 U.S.C. § 111(a), claiming benefit pursuant to 35 U.S.C. §§ 119-120 of the filing dates of the following Provisional Applications:

Serial No. 60/401,758 filed on August 8, 2002;

Serial No. 60/429,064 filed on November 26, 2002; and

Serial No. 60/474,924 filed on June 3, 2003.

Provisional Application Serial Nos. 60/401,758, 60/429,064 and 60/474,924 are incorporated herein by reference for all they disclose.

BACKGROUND OF THE INVENTION1. Technical Field of the Invention

[0002]. The present invention is directed to headgear comprising slow recovery viscoelastic polyurethane foam with a surface impregnation of silicone, and more specifically, to headgear comprising a shell to dissipate a portion of a force impacting on the headgear and a slow recovery viscoelastic polyurethane foam that absorbs the remainder of the impact force.

2. Description of the Related Art

[0003] Head injuries are a leading cause of death and disability in the United

States. Data collected by the Centers for Disease Control demonstrate that, on average, three hundred thousand sports-related brain concussions occur in the United States each year. Children under the age of fourteen have a greater risk for concussions than do adults. Teenagers that suffered two or more "big hits" to the head can suffer long-term damage to their thinking abilities. Twenty percent of teenagers that have suffered multiple concussions have continuous headaches and suffer sleep and concentration disorders. The damage from concussions can vary from mild, which is completely reversible, to severe which can lead to coma or death.

[0004] A concussion is an injury to the brain cells resulting from trauma to the head. Loss of consciousness is not necessary for a head injury to be considered a concussion. Concussions are graded in severity on a scale of Grade One (mild) to Grade Three (severe). Concussions are considered to be Grade One when there is no loss of consciousness and symptoms last less than fifteen minutes. A Grade Two concussion is when there is no loss of consciousness, with symptoms lasting longer than fifteen minutes. A Grade Three concussion is when there is any loss of consciousness.

[0005] Though the incidence of concussions at the amateur levels of ice hockey are not known, it is thought to be a fairly common occurrence. A hockey study from Canada surveying players throughout all professional levels in the sport demonstrated that at least sixty percent of the players suffered at least one concussion

in their career. From October 1, 2001 through December 31, 2001, there were sixty-seven concussions in the National Hockey League. The total number of concussions in the National Hockey League exceeds one hundred per year for a league that has six hundred players.

[0006] The governing bodies at every level of amateur and profession ice hockey mandate the use of helmets. Typically, helmets comprise a rigid outer shell and an energy absorbing liner. The helmet shell functions to: (i) maintain the energy absorbing liner in position upon impact, (ii) prevent penetration of sharp objects, and (iii) dissipate the impact's energy prior to it reaching the energy absorbing liner.

[0007] The helmet shell prevents injury to the head by decreasing the impact force to the brain. Of all the sports requiring certification of their helmets, ice hockey has the lowest certification standards. Helmet shells are typically made from a composite material or a thermoplastic material. Thermoplastic helmet shells bend to absorb impact energy. Thermoplastic helmet shells are easy to mold and color, and are inexpensive to manufacture. Thermoplastic helmet shells deform more and are less rugged than composite helmet shells. Most reinforced thermoset resin shells are considered stronger than typical injection molded plastic shells. Thermoset resin shells are not considered viscoelastic. This means that the thermoset resin shell does not indent with the application of a force. In general, if the thermoset resin shell indents, the impact force is more concentrated in the zone of indentation and less dissipated throughout the surface of the thermoset resin shell.

[0008] A composite helmet shell is more rugged and deforms less than the thermoplastic helmet shell. A composite helmet shell delaminates to absorb impact energy. Delamination is microscopic separation of the fiber layers. A composite is a mixture of components whose combined physical strength is greater than their individual strength. Composite helmet shells are usually made out of epoxy resin and reinforced with fiberglass, carbon or Kevlar. Reinforcing resin with fibers increases the tensile strength by severalfold. The different fibers used within the composite produce different characteristics (tensile strength, compressive strength, flexural strength and abrasion resistance). Motorcycle crash helmets demonstrate the state-of-the-art. Motorcycle helmet shells are made of reinforced epoxy resins and are designed to withstand high-speed impact.

[0009] Injection molded plastic helmet shells vary significantly in strength, weight and are viscoelastic. ABS is the standard type of plastic used for injection molded helmet shells. In some types of helmet shells, injection molded plastic can be very strong, e.g., football helmets or lacrosse helmets.

[0010] Energy absorbing liners are made from either open-cell foam or closed-cell foam. Energy absorbing liners compress as they absorb energy. The purpose of the energy absorbing liner is to decrease the energy of the impact force. This is called impact attenuation. If an egg were dropped onto an energy absorbing liner, it would either crack or stay whole, based on the amount of energy absorbed by the energy absorbing liner. Open-celled foam will rebound after it is compressed from

an impact. Polyvinyl padding is a type of celled foam commonly used in hockey helmets as an energy absorbing liner. Expanded polystyrene (EPS) is a type of closed-cell foam that is the most commonly energy absorbing liner used today in hockey helmets. EPS is a type of STYROFOAM used for packaging protection. EPS is compressed and crushed as it absorbs energy. While EPS attenuates impact force well and is considered the “gold standard” in the helmet market, impacts produce permanent damage to the EPS material. Minor impacts to the helmet shell cause microscopic cracks in the EPS, which can seriously destroy its impact attenuation performance.

[0011] Most urethane foams are elastic in that the foam deflects under a load, and return a force to the load that is equal to the deflection of the elastic material multiplied by its stiffness. When pressure is applied to common urethane foam, like a spring, the foam deflects and returns a force that is proportional to the amount of deflection. Areas of greatest deflection (i.e., greatest pressure) receive the greatest return force. These pressure hot spots can restrict blood circulation to portions of the body.

[0012] Viscoelastic foams have both viscous and elastic response properties. The viscous response property evenly distributes a load, and the elastic response property allows the foam to support a static load. “Viscous” refers to a fluid response that flows away from the applied load or applied force, in that the fluid redistributes the applied load or applied force. Viscoelastic materials redistribute the

applied load or applied force away from the point of contact.

[0013] Slow recovery viscoelastic polyurethane foam molds, shapes, and adjusts to the surface it is in contact with the application of heat. In athletic headgear, for example, the athlete's head causes the application of heat to the slow recovery viscoelastic polyurethane foam. CONFOR foam displays this characteristic greater than other viscoelastic polyurethane foams. Typically, athletic headgear comprises an outer shell and an inner energy absorbing liner for absorbing impacts suffered during the course of an athletic contest. An energy absorbing liner comprising viscoelastic polyurethane foam absorbs energy transferred from the outer shell, if the head represents the final transfer point of the impact energy. Naturally, the viscoelastic polyurethane foam should absorb as much impact energy as possible prior to being completely compressed. Of course, the greater the surface area of the viscoelastic polyurethane foam contacting the skull, the greater the energy dissipation and absorption there will be prior to the viscoelastic polyurethane foam reaching maximum compression (bottoming out). The viscoelastic polyurethane foam should return to its pre-impact shape after the impact.

[0014] Ice hockey involves players reaching impact speeds greater than any other contact sport. The helmet shell used in ice hockey is different than the helmet shell in any other sport. For a helmet shell to be accepted by the hockey community, it must have a certain cosmetic appearance. The helmet shell must cover the forehead, temples, crown, and back of the head. Hockey players will not wear

helmets that are overly large, or have the shape or appearance of a motorcycle crash helmet or football helmet. The plastic used in hockey helmet shells has obviously less impact resistance. In fact, the plastic used in some hockey helmet shells might even be considered an adornment (the clear fragile plastic now used in CCM x-ray helmets). Typically, hockey helmet shells have their least strength on the sides (temples) where the helmet shell loses its curvature, the openings are located for the ears and the energy absorbing liner is at its thinnest. Ice hockey helmet shells made of plastic are most vulnerable in this region.

[0015] Typical hockey helmets do not meet the same standard of protection that football or lacrosse helmets meet. The customary construction of ice hockey helmets uses helmet shell halves that slide together front to back. This interaction of the helmet shell halves is the primary adjustment in most helmets. The padding components are typically arranged to complement this action or at least not interfere with the adjustment. The current construction fails to keep the helmet secured on the head. Critically, hockey helmets typically do not fit humanoid head forms very well, and poor fit can dangerously compromise the function of the helmet.

#### SUMMARY OF THE INVENTION

[0016] The invention has been made in view of the above circumstances and to overcome the above problems and limitations of the prior art, and provides a helmet comprising a slow recovery viscoelastic foam with a surface impregnation of

silicone to retard moisture absorption. The invention further provides a helmet comprising a shell that dissipates a portion of an impact force delivered to the helmet and a slow recovery viscoelastic foam that absorbs the remainder of the impact force.

[0017] Additional aspects and advantages of the invention will be set forth in part in the description that follows and in part will be obvious from the description, or can be learned by practice of the invention. The aspects and advantages of the invention can be realized and attained by means of the instrumentalities and combinations particularly pointed out in the appended claims.

[0018] A first aspect of the present invention provides a helmet for cushioning a head during a sudden impact, and the helmet comprises a helmet shell, and an energy absorbing protective liner fitted to an interior surface of the helmet shell. The energy absorbing protective liner includes a slow recovery viscoelastic material with surface impregnation of a waterproofing material. The energy absorbing protective liner can be formed from slow recovery viscoelastic polyurethane foam with silicone as the waterproofing material.

[0019] A second aspect of the present invention provides a helmet for cushioning a head during a sudden impact, and the helmet comprises a helmet shell and a plurality of energy absorbing protective pads arranged on an interior surface of the helmet shell. Each of the energy absorbing protective pads comprises a slow recovery viscoelastic material with surface impregnation of a waterproofing material. Each energy absorbing protective pad can be formed from slow recovery viscoelastic

polyurethane foam with silicone as the waterproofing material. Advantageously, each of the energy absorbing protective pads can be shaped into pads of variable thickness and size.

[0020] A third aspect of the present invention provides a helmet for cushioning a head during a sudden impact, and the helmet comprises a helmet shell having a humanoid head shape, with lateral members at least partially disposed around a circumference of the helmet shell. The helmet further includes an energy absorbing protective liner fitted to an interior surface of the helmet shell, comprising a slow recovery viscoelastic material with surface impregnation of a waterproofing material. The energy absorbing protective liner can be formed from slow recovery viscoelastic polyurethane foam with silicone as the waterproofing material. The helmet shell has a thickness of at least 2 millimeters, and the lateral members are thicker than other portions of the helmet shell. The lateral members disperse an impact force from a point of contact to other portions of the helmet shell. Each of the lateral members is comprised of an upper lateral member and a lower lateral member, and the upper lateral member and the lower lateral member are separated by a lateral channel. The helmet shell also includes a strap attachment member, and the lower lateral member is angled towards the location where the strap attachment member is disposed on the helmet shell. The helmet shell can be manufactured from injection molded plastic, or from pressure molded thermoset resin reinforced with glass fiber, KEVLAR fiber or carbon fiber. The helmet shell disperses at least thirty percent of an impact force

applied to the helmet shell.

[0021] A fourth aspect of the present invention provides a helmet for cushioning a head during a sudden impact, and the helmet comprises a helmet shell having a humanoid head shape, and lateral members disposed around a circumference of the helmet shell. The helmet further includes a plurality of energy absorbing protective pads arranged on an interior surface of the helmet shell. Each of the energy absorbing protective pads comprises a slow recovery viscoelastic material with surface impregnation of a waterproofing material. The energy absorbing protective liner can be formed from slow recovery viscoelastic polyurethane foam with silicone as the waterproofing material. Advantageously, each of the energy absorbing protective pads can be shaped into pads of variable thickness and size.

[0022] The above and other aspects and advantages of the invention will become apparent from the following detailed description and with reference to the accompanying drawing figures.

#### BRIEF DESCRIPTION OF THE DRAWINGS

[0023] The accompanying drawings, which are incorporated in and constitute a part of this specification illustrate embodiments of the invention and, together with the description, serve to explain the aspects, advantages and principles of the invention. In the drawings,

[0024] FIG. 1 depicts a side view of a helmet according to a preferred embodiment of the present invention;

[0025] FIG. 2 depicts a side view of a helmet according to a preferred embodiment of the present invention;

[0026] FIG. 3 depicts a rear cross sectional view of an energy absorbing protective liner along line III-III shown in FIG. 1;

[0027] FIG. 4 depicts a rear view of a helmet according to a preferred embodiment of the present invention;

[0028] FIG. 5 depicts a rear view of a helmet according to a preferred embodiment of the present invention;

[0029] FIG. 6 depicts a side cross sectional view of an energy absorbing protective liner along line VI-VI shown in FIG. 4;

[0030] FIG. 7 depicts a rear cross sectional view of individual energy absorbing protective liner pads along line III-III shown in FIG. 1; and

[0031] FIG. 8 depicts a rear view of a helmet according to a preferred embodiment of the present invention;

#### DESCRIPTION OF THE PREFERRED EMBODIMENTS

[0032] A detailed description of the preferred embodiments of the present invention will now be given referring to the accompanying drawings.

[0033] Referring to FIGS. 1 and 2, a side view of a preferred embodiment of

the energy-absorbing helmet is illustrated. The helmet 1 comprises a helmet shell 2 and an energy absorbing liner insert 4 having an exterior surface 5 that conforms to the interior surface 3 of the helmet shell 2. The helmet shell 2 itself is comprised of thermoset plastic with reinforcing structures disposed thereon. The reinforcing structures will be described in more detail below.

[0034] Referring to FIG. 3, a sectional view of the energy absorbing liner insert 4 without the helmet shell 2 along lines III-III is illustrated. The energy absorbing liner insert 4 is comprised of a foam layer 6 and a silicone layer 7. The silicone layer 7 is bonded to the foam layer 6, and the interior surface 8 formed by the silicone layer 7 is in contact with the athlete's head.

[0035] Referring to FIGS. 4 and 5, a rear view of a preferred embodiment of the energy-absorbing helmet is illustrated. Again, the energy absorbing liner insert 4 is in direct contact with the interior surface 3 of the helmet shell 2.

[0036] Referring to FIG. 6, a side sectional view of the energy absorbing liner is illustrated, and the layering of the silicone layer 7 on the interior of the energy absorbing liner is shown. In a preferred embodiment, the silicone layer 7 is bonded to the interior surface of the foam layer 6. Preferably, the foam layer 6 is viscoelastic polyurethane foam, and more preferably, the viscoelastic polyurethane foam is CONFOR foam. The silicone layer 7 penetrates into the open cell lattice network of the viscoelastic polyurethane foam layer 6. The silicone layer 7 is cured at room temperature, since heating the viscoelastic polyurethane foam layer 6 will degenerate

the structure of the viscoelastic polyurethane foam layer 6. A primer coat (not shown) can be applied to the interior surface of the foam layer 6 to enhance the adherence of the silicone layer 7. The silicone layer 7 can be applied as a 1-part compound or as a 2-part compound (or more than 2 parts if that becomes available). Pigment can be added to the silicone layer 7 for cosmetic reasons. The silicone layer 7 can be applied to only one surface or more than one surface of the foam layer 6.

[0037] Applying the silicone layer 7 to a surface of the foam layer 6 prevents airflow through that surface. Application of silicone layer 7 to more than one surface will affect airflow through the foam layer 6 and its compression characteristics. Typically, open cell polyurethane foams have a Young's modulus in the order of 20 kilopascals due to the flow of air. Closed cell foam traps air and has a Young's modulus of approximately 100 kilopascals. This is discussed further in N.J. Mills, *Micromechanics of Polymeric Foams*, which is herein incorporated by reference.

[0038] The application of the silicone layer 7 over parts of the foam layer 6 can be tailored to specifically modify the stress/strain characteristics of the foam layer 6 and enhance its energy absorption characteristics. A full silicone layer 7 is applied over the surface of the foam layer 6 that will be in contact with the athlete's head.

[0039] The silicone layer 7 has multiple functions: (i) it can be tailored to affect airflow through the foam layer 6 and hence affect the energy absorbing characteristics of the foam layer 6, and (ii) it prevents water absorption by the foam layer 6. The foam layer 6 has a microscopic structure similar to that of the sponge

and easily absorbs water. Uncoated open cell polyurethane foam can absorb many times their weight in water. Water absorbed by open cell polyurethane foam adds to the weight of the open cell polyurethane foam. The water typically absorbed by the open cell polyurethane foam is that produced by the athlete during sweating. Any added weight in open cell polyurethane foam padding increases the inertia of the head during athletic activities and decreases the effectiveness of the head protection. Therefore, to maximize the protectiveness of the energy absorbing liner insert 4, it is important to eliminate the absorption of water.

[0040] The silicone layer 7 maintains the sanitation of the energy absorbing liner insert 4. Sweating produces water, which is absorbed by uncoated open cell polyurethane foam. Athletic activities in warmer environments typically produce a great deal of sweat, unlike sports such as skiing and snowboarding where the athlete might not produce as much sweat in the helmet. The water from sweating and the contact from the athlete's skin can promote the proliferation of bacteria. Bacteria produce odors and can promote skin infections (e.g., folliculitis). Helmets are typically stored in dark or confined areas (e.g., athletic bags) that can further promote bacterial production. The silicone layer 7 coated on the foam layer 6 minimizes bacterial growth and enhances a sanitized helmet.

[0041] Viscoelastic open cell polyurethane foam has a tendency to degenerate with friction. This is commonly seen when using this type of foam for padding in a sports helmet. The friction causes a fine granular layer of foam to wear off from

the foam padding, usually ending up in the athlete's hair or on the athlete's skin. Bonding the silicone layer 7 to the surface of the foam layer 6 that will be in contact with the athlete's skin prevents this degeneration.

[0042] In a preferred embodiment, the foam layer 6 is viscoelastic polyurethane foam of variable thickness and size for a helmet to be custom fit by a retailer. The viscoelastic polyurethane foam layer 6 has a unique characteristic in that warming easily deforms it, and thus it conforms to shape of the athlete's head when applied. The application of the silicone layer 7 does not interfere with this characteristic.

[0043] There is typically a limitation in the number of differently sized helmet shells available to the athlete. To maximize the protection afforded to the athlete, the helmet shell should have a custom fit to the athlete's head. The helmet should fit snugly and the padding should have intimate contact with the surface of the head throughout all areas of the helmet shell.

[0044] In a preferred embodiment, the thickness and size of the viscoelastic polyurethane foam layer 6 will vary in order to custom size a helmet 1 to each athlete. Within the helmet shell 2, as much viscoelastic polyurethane foam layer 6 as possible be present within the helmet shell 2 in order to maximize the energy absorption in an impact. Thus, an athlete could use the same helmet shell 2 with several differently sized energy absorbing liner inserts 4. The size and thickness of each energy absorbing liner inserts 4 would be based on the interior size of the helmet shell 2 and the size of the athlete's head. In the case of a growing young

athlete, as the size and shape of the athlete's head changed, a new energy absorbing liner insert 4 could be fitted to the athlete's head, thereby insuring a snug fit for maximum protection.

[0045] Alternatively, instead of a unitary energy absorbing liner insert 4, individual pads spaced within the helmet shell 2 can comprise the energy absorbing liner insert 4. Preferably, the individual pads would be viscoelastic polyurethane foam. The individual pads are arrayed within the helmet shell 2 with minimal distance between them in order to maximize energy absorption.

[0046] Referring to FIG. 7, an embodiment of a helmet shell 2 with multiple helmet pads 4a-4g is illustrated. For the sake of clarity, each of the pads is shown without the silicone layer 7. Each of the helmet pads 4a-4g has a different thickness in order to illustrate how helmet pads of different thickness can be used to achieve a snug fit. For example, the helmet pad 4a is not as thick as the helmet pad 4g. Typically, each of these helmet pads would be the same thickness. However, if the helmet shell 2 is loose in that particular region, the thickness of one or more of the helmet pads can be increased to tighten the fit of the helmet shell 2. Similarly, helmet pads 4c-4e (in various thicknesses) can be used to adjust the height of the helmet shell 2 with respect to the athlete's head.

[0047] Thermoset resin is the "glue" that is needed to hold glass fibers together in a composite helmet shell. Thermoset resins are a family of plastics that do not melt, but chemically degrade at high temperatures. Thermoset resins are created by

mixing two base materials just like epoxy glues (epoxy glues are thermoset resins). One of the ingredients is a catalyst that, when combined with the other agents and heat during molding, will solidify the mixture locking itself and the glass fibers into a rigid state. In compression molding applications, very little catalyst is used so that the liquid resin remains stable at room temperature; the heat and pressure of the molding operation initiates the chemical reaction to solidify the resin.

[0048] Thermoset resins by themselves have relatively little strength. The strength of a thermoset composite material comes primarily from the fibers of glass or other materials that are bonded together by the resin. There are three types of reinforcing fiber in common use today. Plastic materials (Kevlar, PBI) have very high strength and toughness but very low stiffness, and perform most efficiently when they are allowed to flex under load. In addition, these materials tend to be more affected by heat than other reinforcing fiber materials. Carbon fibers provide both strength and very high rigidity but are electrically conductive and therefore unsuitable for applications requiring high levels of electrical insulation. The third material family, glass fiber, provides the best combination of high strength, high stiffness, electrical insulation and cost of any reinforcing material in common use.

[0049] The challenge in designing an effective composite material is getting the right mix of a good thermoset resin and high content of glass. The performance of the composite is a function of the structural strength and adhesive properties of the resin, the length of the glass fibers and the amount of glass reinforcement in the

composite. By increasing the strength of the resin and/or the length of the glass fibers, it can be possible to reduce the content of glass without sacrificing performance. This may result in a product that is easier to mold and has a better surface appearance. The glass fiber is heavier than the resin so getting the right mix also creates the best potential for a lighter helmet shell.

**[0050]** As a general rule, thermoplastic materials become softer and tougher as they get warmer, and harder and more brittle as the temperature goes down. Until relatively recently, it was possible to obtain either great heat resistance or great impact resistance, but not both in the same material.

**[0051]** In recent years, new thermoplastic materials have been developed which successfully combine both heat resistance and impact resistance. Polycarbonate began this trend in the 1960s; more recent materials such as GE's ULTEM and Amoco's RADEL now provide comparably high levels of impact resistance with heat resistance far exceeding that of polycarbonate. While the cost of these resins is very high, it is justified in certain demanding applications by their exceptional performance. As technology moves forward, these materials will continue to improve and expand in applications.

**[0052]** The helmet shell 2 play several vital roles. The helmet shell 2 is typically two to six millimeters thick and is either injection-molded thermoplastic or a pressure molded thermoset resin reinforced with glass fiber, KEVLAR fiber or carbon fiber. The helmet shell 2 is responsible for thirty to forty percent of the

impact energy attenuation. The impact energy absorbed by the helmet shell 2 depends upon:

1. The thickness and material used for the helmet shell 2. Thermoplastic shells absorb energy by viscoelastic deformation. Thermoset resin reinforced shells have lower elastic limits and undergo fiber fracture or delamination with impact energy.
2. The shape of the impacting objects. For example, flat objects impact lower strains than convex rigid objects.
3. The distribution of local forces from an impact. The helmet shell 2 distributes a localized impact force throughout the surface of the helmet shell 2. This distributed impact force is greatest at the point of impact and the distributed impact force will lessen as the radius from the distributed impact force increases.

[0053] If the athletic headgear did not have a helmet shell 2, the energy absorbing liner insert 4 would have to be significantly thicker to provide the same type of protection. In the present invention, the helmet shell 2 protects the upper face, temples and ears from impact, and the helmet shell 2 slides easily on impact surfaces. The sliding of the helmet shell 2 on the impact surfaces decreases the rotational forces of the impact. The helmet shell 2 also supports other safety components, e.g., straps, face masks, etc.

[0054] The helmet shell 2 is responsible for a significant proportion of the impact energy dissipated by impact on to rigid objects. The stiffness of the helmet shell 2 plays a role in the dissipation of energy from an impact. The greater the

stiffness of the helmet shell 2, the greater the dissipation of energy. Thermoplastic helmet shells are less stiff than thermoset resin impregnated fiber helmet shells, and thus, thermoplastic helmet shells also rebound more. Certain types of thin walled helmet shells serve only to prevent the energy absorbing liner from breaking apart during impact (e.g., bicycle helmets).

[0055] The helmet shell 2 of the present invention has the following design criteria to protect the athlete's head:

1. The helmet shell 2 has sufficient thickness to provide rigidity.
2. The helmet shell 2 is comprised of a material that provides rigidity.
3. The helmet shell 2 absorbs thirty to forty percent of the impact energy.

In a preferred embodiment, the helmet shell 2 is a unitary structure. Because of the helmet shell's rigidity and strength, the energy from an impact on the helmet shell should be dissipated over the surface of the helmet shell 2 to minimize focused energy being transferred to a focused point on the energy absorbing liner insert 4. The energy not dissipated by the helmet shell's rigid surface is then transferred to the energy absorbing liner insert 4.

[0056] Typically, the side surfaces protecting the areas in front of, behind and slightly above the ear are less round than the top, front, and back surfaces of a sports helmet. These side surfaces are usually less rigid and deform greater with impact.

[0057] In the present invention, the side surfaces of the helmet shell are manufactured with more rigidity to provide greater impact attenuation. This increase

in rigidity is accomplished in several different ways. For helmet shell 2 constructed of injected thermoplastic, increasing the thickness of the side surfaces thicker provides reinforcement to the side surfaces. For a helmet shell 2 constructed of reinforced thermoset resin, the side surfaces comprise additional layers of the fiber reinforcement mixed with the thermoset resin. As discussed above, the fiber reinforcement might comprise cloth fiber, glass fiber, KEVLAR fiber, carbon fiber or an equivalent thereof. Preferably, in the present invention, if a thermoset resin is used to manufacture the helmet shell 2, the completed helmet shell 2 will include at least three layers of fiber reinforcement to maximize impact dissipation.

[0058] Referring to FIG. 1, the helmet shell 2 of the present invention utilizes structures incorporated into the helmet shell 2 itself to increase the rigidity and the impact attenuation. In a preferred embodiment of the helmet shell 2, a strut 10 is disposed between the strap attachment member 11 and a rear portion of the ear cutout 13. The strut 10 traverses the ear cutout 13 at an angle, and reinforces the strap attachment member 11 for attenuating frontal impacts. Preferably, the helmet shell 2 further comprises a lateral member 13 that acts as a belt wrapped around a circumference of the helmet shell 2. The lateral member 13 is integral to the helmet shell 2, provides additional structural rigidity, and assists in impact dispersion. In a preferred embodiment, the lateral member 13 would be included in a unitary helmet shell 2. The lateral member 13 is comprised of at least an upper lateral member 14 and a lower lateral member 15, and a lateral channel 16 separates the upper lateral

member 13 from the lower lateral member 14. Together, the upper and lower lateral members 14, 15 serve to absorb a portion of an impact force from the point of contact on the helmet shell 2, and to dissipate the remainder of the impact force to other areas of the helmet shell 2. The energy absorbing liner insert 4 attenuates the remainder of the impact force. The upper and lower lateral members 14, 15 also increase the surface area of the helmet shell 2, which further serves to attenuate the force of an impact. In a preferred embodiment, the lateral member 13, the upper lateral member 14 and the lower lateral member 15 are two to six millimeters thick, although they can be made thicker if desired. In a preferred embodiment, to further reinforce the rigidity of the helmet shell 2 and to assist in the dissipation of an impact force, the upper and lower lateral members 14, 15 and the lateral channel 16 have angled portions 22, 23, 24 as shown in FIG. 1. The angled portions 22, 24 of upper and lower lateral members 14, 15 and the angled portion 23 of lateral channel 16 are disposed above the strap attachment member 11. The angled portions 22, 24 of the upper and lower lateral members 14, 15 and the angled portion 23 of lateral channel 16 function to provide additional rigidity in a portion of the helmet shell 2 that has considerable flexure in conventional helmet shells. The angled portions 22, 24 of the upper and lower lateral members 14, 15 and the angled portion 23 of lateral channel 16 assist the strut 10 in reinforcing the strap attachment member 11 for attenuating frontal impacts. The downward angle of the angled portion 24 of the lower lateral member 15 and the angled portion 23 of lateral channel 16 is between thirty and sixty

degrees, although the angled portion 24 of the lower lateral member 15 and the angled portion 23 of lateral channel 16 can be disposed at other angles as well. Referring to FIG. 7, the upper lateral member 14 and the lower lateral member 15 are thicker than other portions of the helmet shell 2. As a non-limiting example, if the upper portion of the helmet shell 2 was 2 millimeters thick, the upper lateral member 14 and the lower lateral member 15 might be five to six millimeters thick.

[0059] Referring to FIG. 4, the disposition of the upper and lower lateral members on the rear of the helmet shell 2 is illustrated. Both the upper members 14, 14' and the lower members 15, 15' continue to wrap around the circumference of the helmet shell 2 to a point at the back of the helmet shell 2. In a preferred embodiment, the lateral member 13, 13' from each side of the helmet shell 2 is smoothly contoured into the helmet shell 2 so there are no projections that could possibly injure the helmet wearer or another player.

[0060] Referring to FIG. 8, the disposition of the upper and lower lateral members 14, 14', 15, 15' on the front of the helmet shell 2 is illustrated. The lateral members 13, 13' from each side of the helmet shell 2 continue to wrap around the circumference of the helmet shell 2 and merge together in the front of the helmet shell 2. In a preferred embodiment, the lateral member 13, 13' from each side of the helmet shell 2 is smoothly merge together so there are no projections that could possibly injure the helmet wearer or another player. The angled portions 24, 24' of the lower lateral members 15, 15' can be seen in FIG. 8 as well. Vent holes 21 are

provided through the lateral member 13, 13' for cooling purposes.

[0061] The foregoing description of preferred embodiments of the invention has been presented for purposes of illustration and description. It is not intended to be exhaustive or to limit the invention to the precise form disclosed, and modifications and variations are possible in light of the above teachings or can be acquired from practice of the invention. The embodiments were chosen and described in order to explain the principles of the invention and its practical application to enable one skilled in the art to utilize the invention in various embodiments and with various modifications as are suited to the particular use contemplated.

[0062] Thus, while only certain embodiments of the invention have been specifically described herein, it will be apparent that numerous modifications can be made thereto without departing from the spirit and scope of the invention. Further, acronyms are used merely to enhance the readability of the specification and claims. It should be noted that these acronyms are not intended to lessen the generality of the terms used and they should not be construed to restrict the scope of the claims to the embodiments described therein.

CLAIMS

What is claimed is:

1. A helmet for cushioning a head during a sudden impact, comprising:  
a helmet shell; and  
an energy absorbing protective liner fitted to an interior surface of the helmet shell, wherein the energy absorbing protective liner comprises a slow recovery viscoelastic material with surface impregnation of a waterproofing material.
2. The helmet according to claim 1, wherein the slow recovery viscoelastic material is slow recovery viscoelastic polyurethane foam.
3. The helmet according to claim 1, wherein the waterproofing material is silicone.
4. A helmet for cushioning a head during a sudden impact, comprising:  
a helmet shell; and  
a plurality of energy absorbing protective pads arranged on an interior surface of the helmet shell, wherein each of the energy absorbing protective pads comprises a slow recovery viscoelastic material with surface impregnation of a waterproofing material.

5. The helmet according to claim 4, wherein the slow recovery viscoelastic material is slow recovery viscoelastic polyurethane foam.

6. The helmet according to claim 4, wherein the waterproofing material is silicone.

7. The helmet according to claim 4, wherein the plurality of energy absorbing protective pads are shaped into pads of variable thickness and size.

8. A helmet for cushioning a head during a sudden impact, comprising:  
a helmet shell comprising a thermoplastic shell having a humanoid head shape, and lateral members at least partially disposed around a circumference of the thermoplastic shell; and

an energy absorbing protective liner fitted to an interior surface of the helmet shell, wherein the energy absorbing protective liner comprises a slow recovery viscoelastic material with surface impregnation of a waterproofing material.

9. The helmet according to claim 8, wherein the helmet shell has a thickness of at least 2 millimeters.

10. The helmet according to claim 8, wherein the thermoplastic shell is an injection molded plastic shell.

11. The helmet according to claim 8, wherein the thermoplastic shell is a pressure molded thermoset resin reinforced with at least one of a glass fiber, KEVLAR fiber or carbon fiber.

12. The helmet according to claim 8, wherein the lateral members are thicker than other portions of the helmet shell.

13. The helmet according to claim 8, wherein the lateral members disperse an impact force from a point of contact to other portions of the helmet shell.

14. The helmet according to claim 8, wherein the helmet shell disperses at least thirty percent of an impact force applied to the helmet shell.

15. The helmet according to claim 8, wherein the slow recovery viscoelastic material is slow recovery viscoelastic polyurethane foam.

16. The helmet according to claim 8, wherein the waterproofing material is silicone.

17. The helmet according to claim 8, wherein each of the lateral members disposed around a circumference of the helmet shell is comprised of an upper lateral member and a lower lateral member, and the upper lateral member and the lower lateral member are separated by a lateral channel.

18. The helmet according to claim 17, wherein the helmet shell further comprises a strap attachment member, and the lower lateral member is angled towards the location where the strap attachment member is disposed on the helmet shell.

19. A helmet for cushioning a head during a sudden impact, comprising:  
a helmet shell comprising a thermoplastic shell having a humanoid head shape, and lateral members disposed around a circumference of the thermoplastic shell; and

a plurality of energy absorbing protective pads arranged on an interior surface of the helmet shell, wherein each of the energy absorbing protective pads comprises a slow recovery viscoelastic material with surface impregnation of a waterproofing material.

20. The helmet according to claim 19, wherein the slow recovery viscoelastic material is slow recovery viscoelastic polyurethane foam.

21. The helmet according to claim 19, wherein the waterproofing material is silicone.

22. The helmet according to claim 19, wherein the plurality of energy absorbing protective pads are shaped into pads of variable thickness and size.



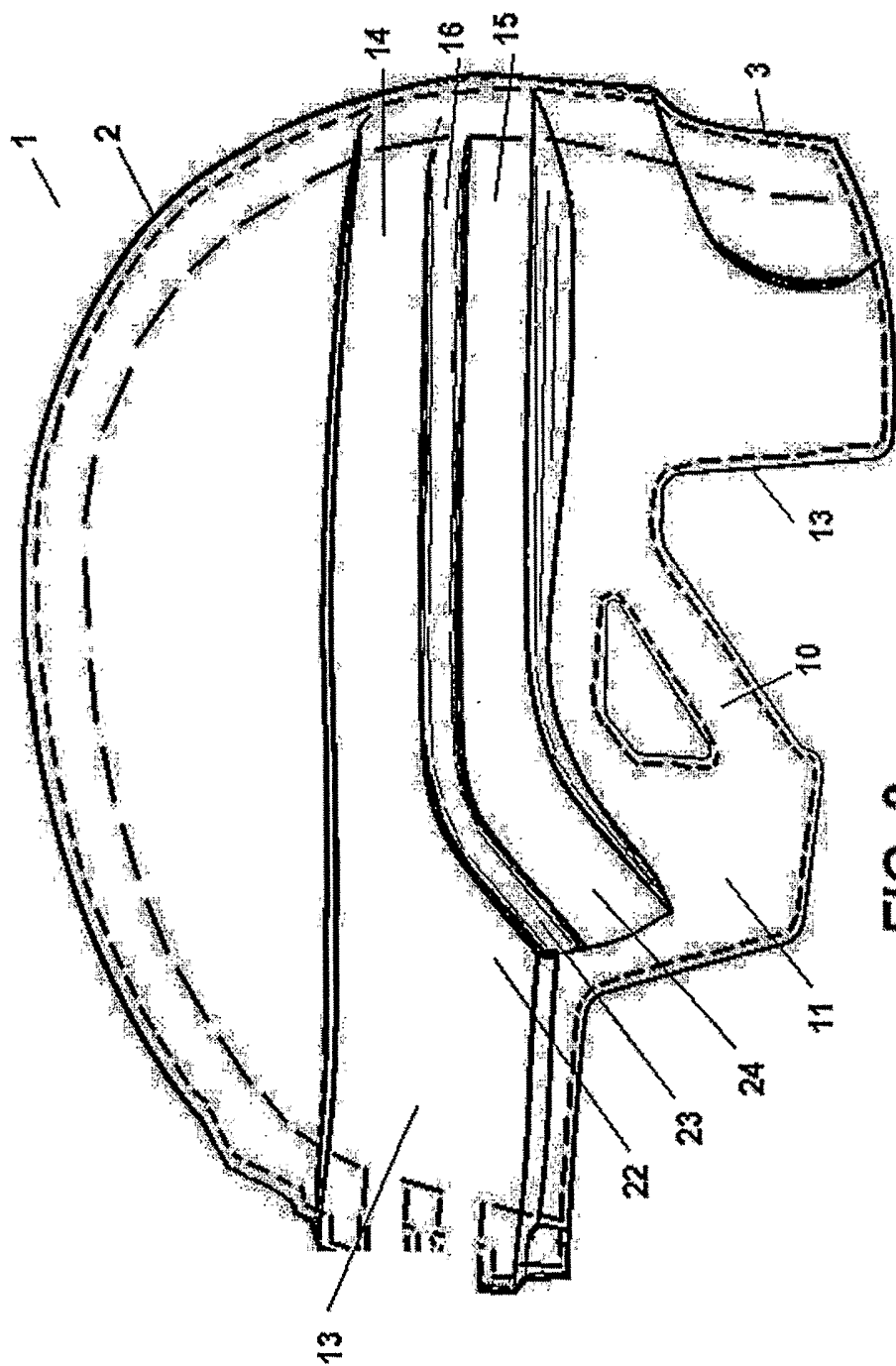

FIG. 2

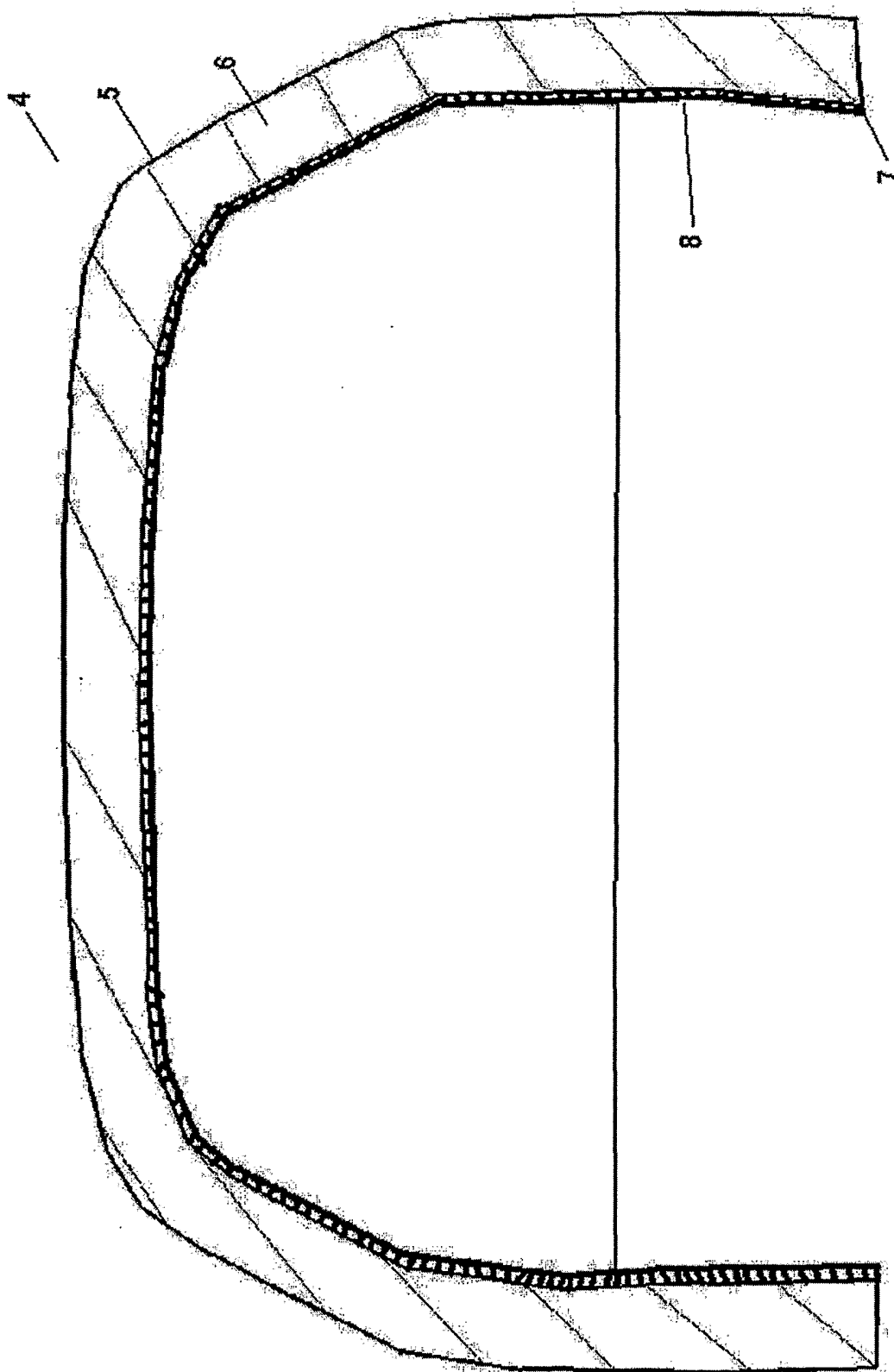

FIG. 3

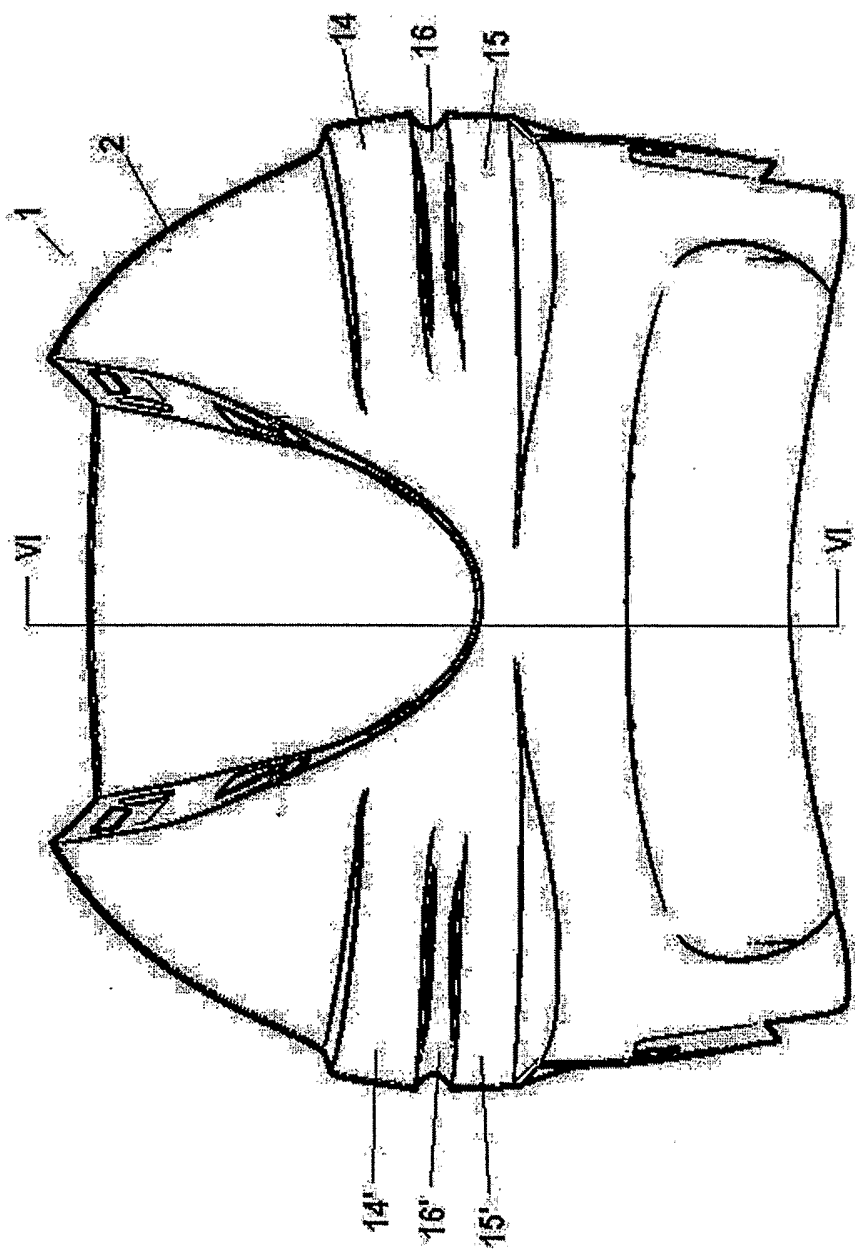

FIG. 4

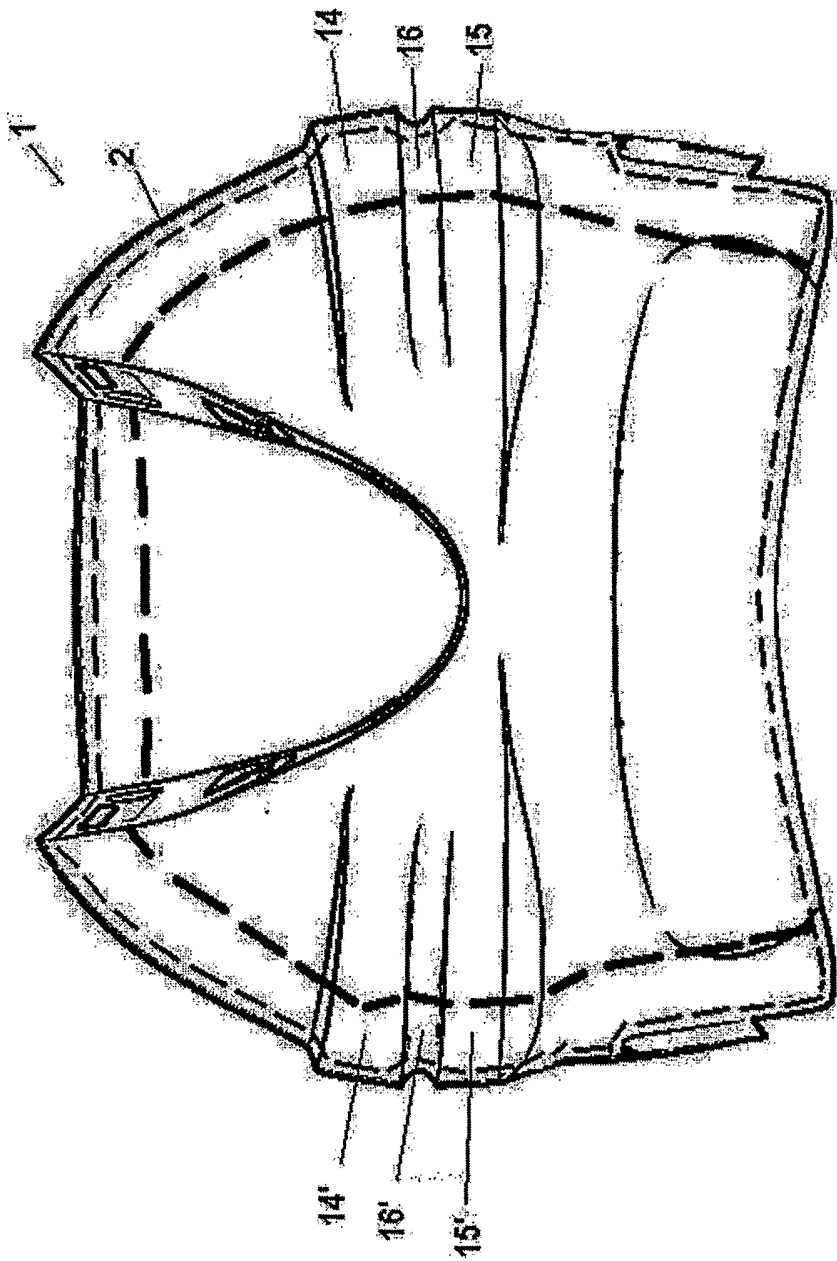

FIG. 5

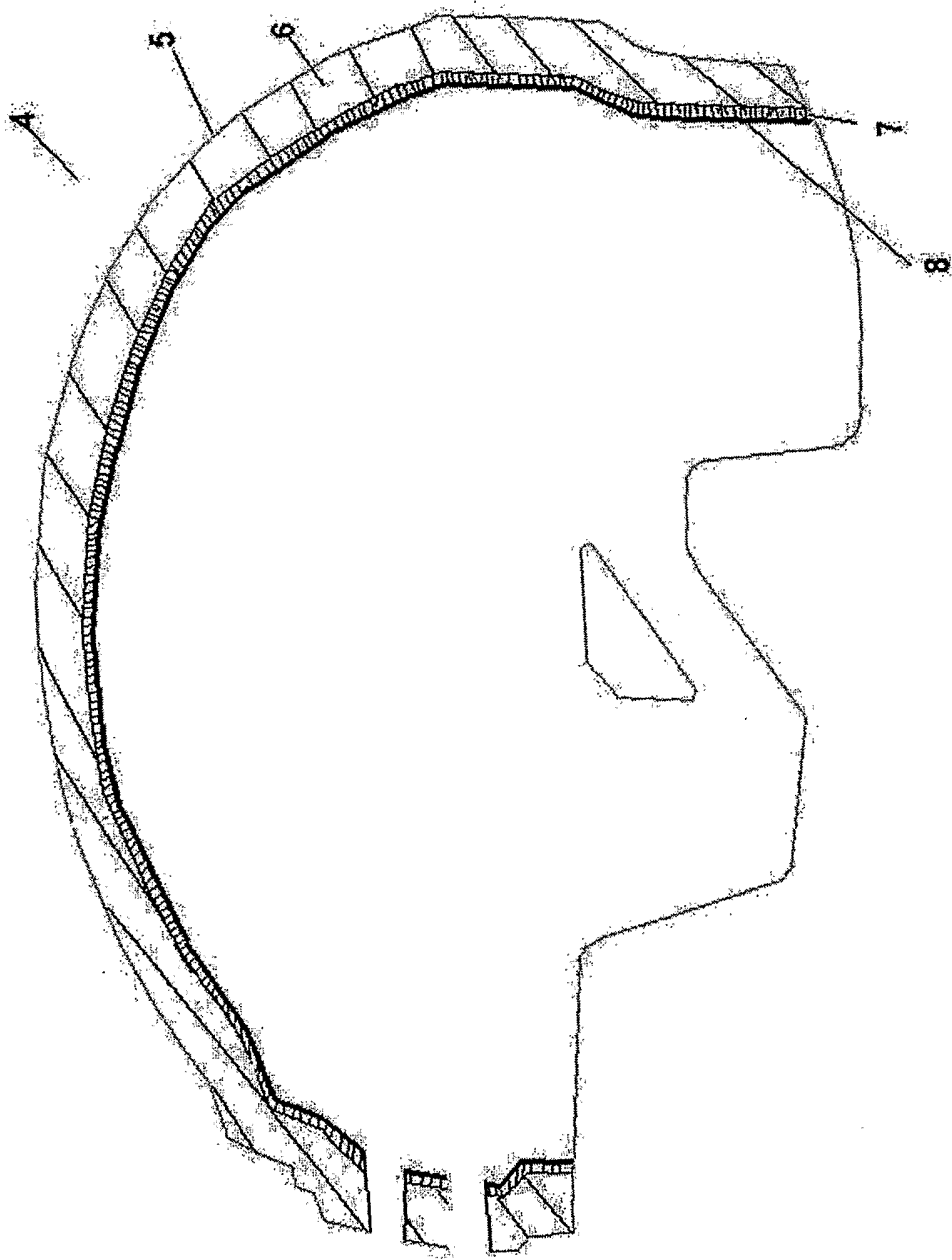

FIG. 6

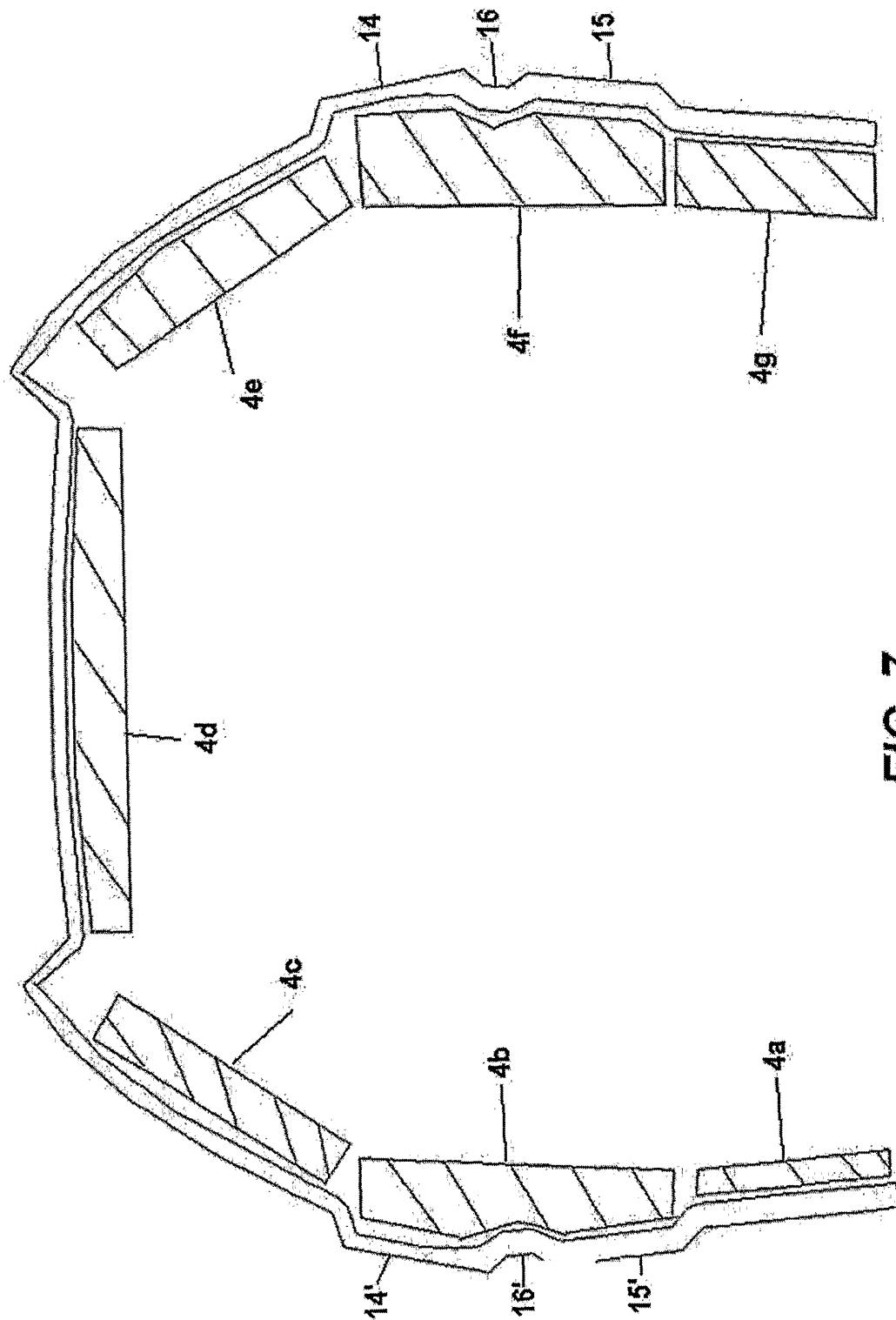

FIG. 7

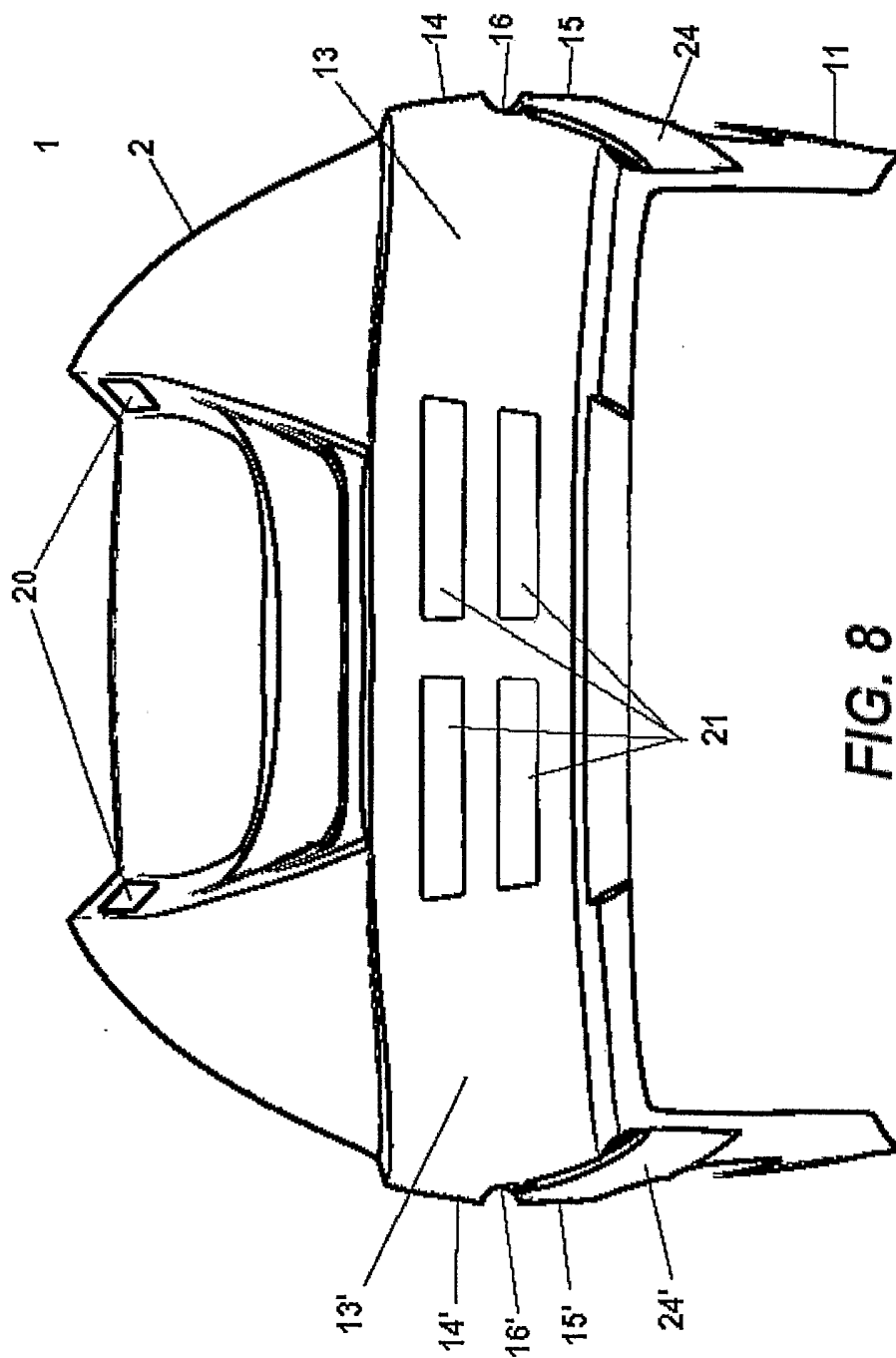

FIG. 8