



US 20090144924A1

(19) **United States**

(12) **Patent Application Publication**
Stein

(10) **Pub. No.: US 2009/0144924 A1**

(43) **Pub. Date: Jun. 11, 2009**

(54) **WEARABLE TOWEL**

Publication Classification

(76) Inventor: **Chazon Stein**, Fisher Island, FL
(US)

(51) **Int. Cl.**
A47K 7/02 (2006.01)
A41D 1/00 (2006.01)

Correspondence Address:
ROBERT M. SCHWARTZ, P.A.
P.O. BOX 221470
HOLLYWOOD, FL 33022 (US)

(52) **U.S. Cl.** **15/210.1; 2/69; 15/209.1**

(21) Appl. No.: **12/056,467**

(22) Filed: **Mar. 27, 2008**

(57) **ABSTRACT**

Related U.S. Application Data

(60) Provisional application No. 60/992,406, filed on Dec. 5, 2007.

A towel easily wrapped and fixed about a body of a wearer, the towel having a substantially planer rectangular main body and at least one opening in the main body configured for securing the towel to the body of the wearer.

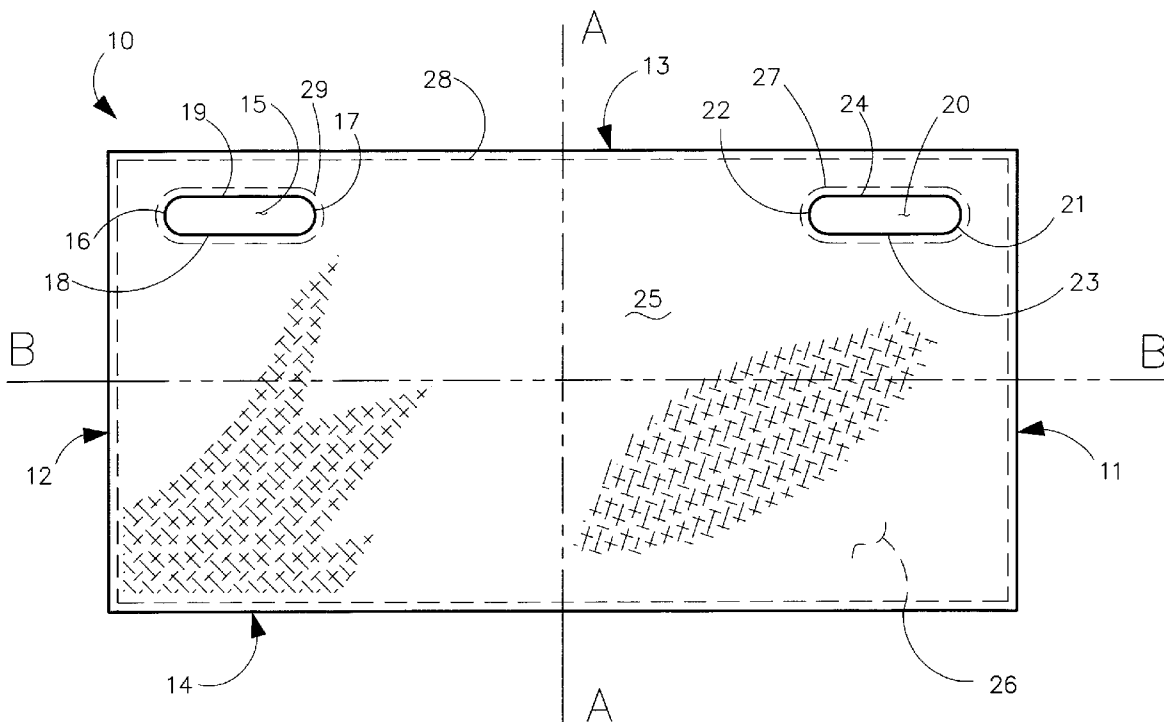

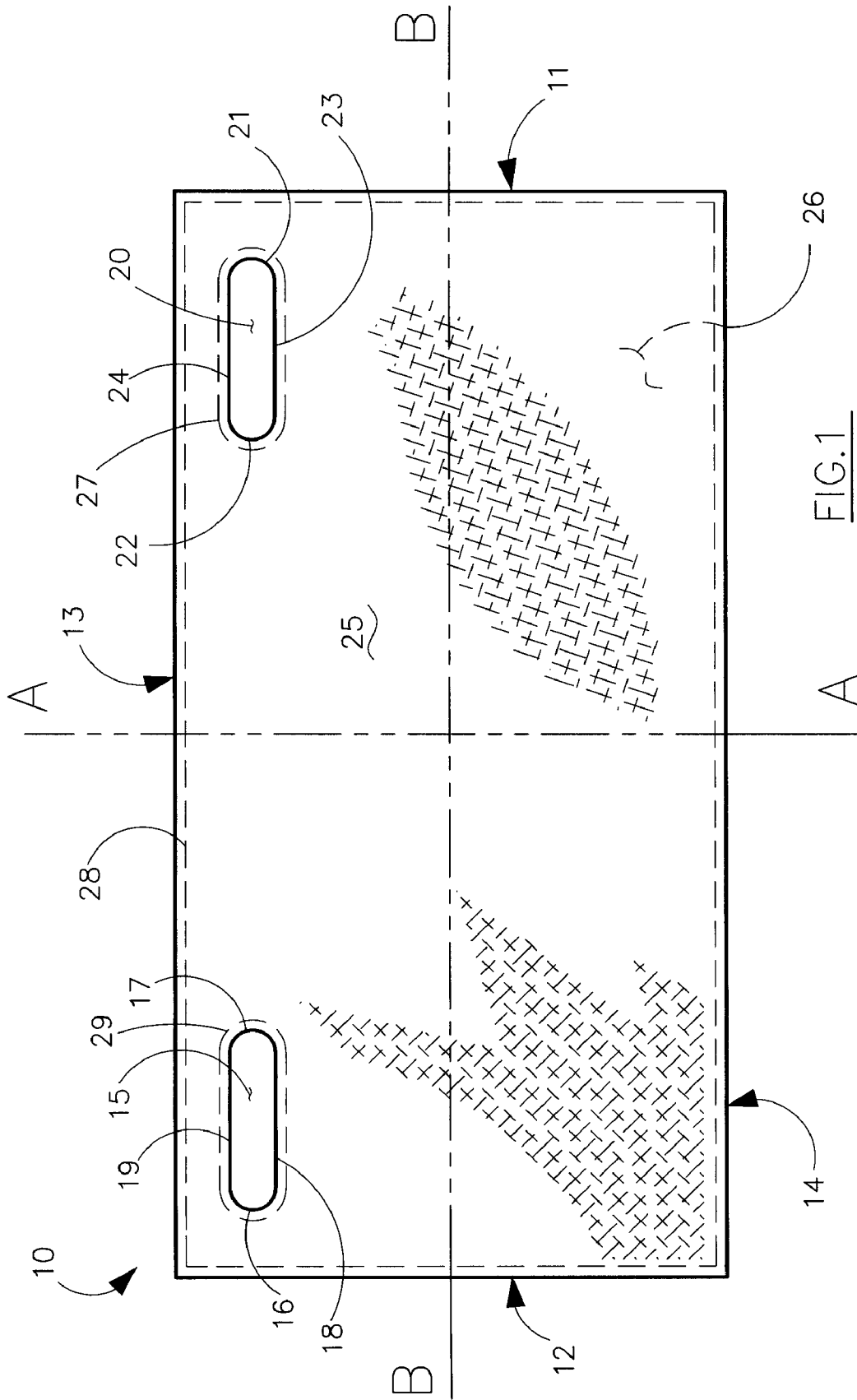

FIG. 1

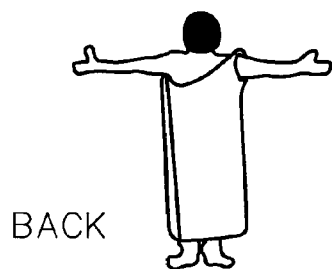
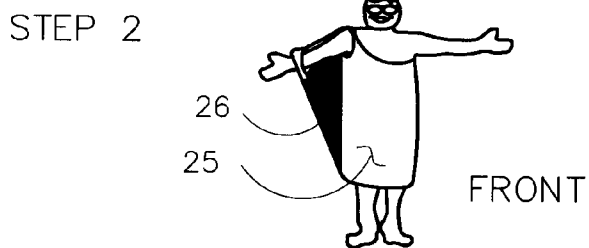
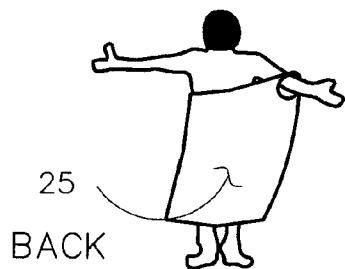
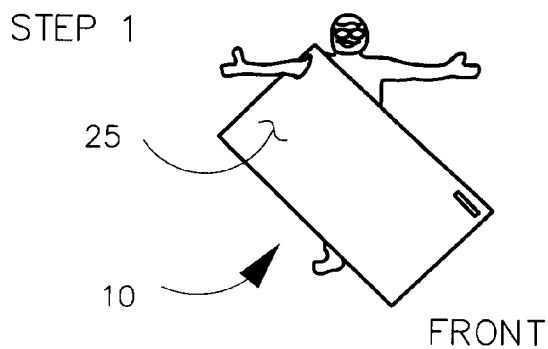
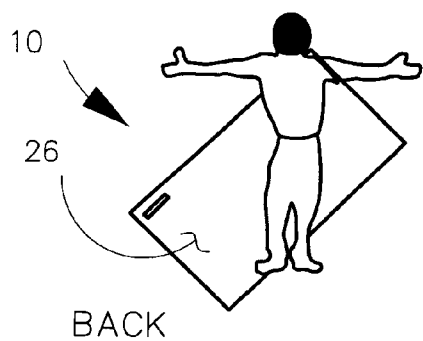

FIG. 2

WEARABLE TOWEL

INDEX TO RELATED APPLICATIONS

[0001] This application claims the benefit of U.S. Provisional Patent Application Ser. No. 60/992,406 filed Dec. 5, 2007 the disclosure of which is incorporated herein by reference in its entirety.

BACKGROUND OF THE INVENTION

[0002] The present invention relates to towels for body wiping, protection and privacy for temporary attachment to a human body during uses that can include physical workout, shaving, applying makeup, being in the presence of other people, between personal care activities, being unclothed in variously inclement surroundings, and/or other activities before being clothed.

[0003] Robes, tote towels and other modifications of towels are well known. In a manner taught by this invention, however, none are known to provide the temporary attachment as in the present invention.

[0004] The subject invention provides a novel, easy to manufacture, and easy to use towel to address the current need.

BRIEF SUMMARY OF THE INVENTION

[0005] The subject invention provides a novel towel configuration that is easily wrapped and fixed into position about the body of a wearer.

[0006] In a preferred embodiment, the towel includes a substantially planer rectangular main body as is commonly known. There are two openings that are congruently placed along the long edge of the towel body.

[0007] In one embodiment, the opening is approximately about 10 inches long and from approximately about 0.25-3 inches wide. The opening, in this embodiment, is set inward from the edge of the longest towel side by about approximately 4 inches. The opening is set inward from the shorter towel side by about approximately about 3 inches.

[0008] In a preferred embodiment the said openings are congruently placed relative to their position to their respective adjacent edges.

[0009] Alternatively, the openings may be positioned in any desired configuration.

[0010] In one embodiment, the openings may have a mechanism by which the sizes of the opening can be adjusted. The said mechanism may be any that is commonly known and can include but would not be limited to buttons, snaps, zipper, Velcro®, hook and loop and the like.

[0011] In an alternative embodiment, the towel may have one opening adjacent to a first side and a mechanism for attaching the second or terminal side once the towel is wrapped around the body of a user.

[0012] The towel may be formed of any acceptable material including but not limited to conventional terrycloth-type material. Terrycloth is a fabric with loops that can absorb large amounts of water. It can be manufactured by weaving or knitting, with weaving on a dobby loom the predominant commercial method, having two beams of longitudinal warp through which the filler or weft is fired laterally.

[0013] Preferably, the regions bordering each of the openings, are reinforced to give structural strength and integrity to the towel such that the repeated motion of placing an arm in

the opening and removing the arm from the opening does not tear or otherwise compromise the integrity of the towel.

BRIEF DESCRIPTION OF THE DRAWINGS

[0014] FIG. 1 is a plan view of the towel of the present invention.

[0015] FIG. 2 depicts sequential steps relating to the use of the towel of the present invention.

DETAILED DESCRIPTION OF THE PREFERRED EMBODIMENTS

[0016] Towel 10 includes a first side 25 and a second side 26 defined by the first vertical side 11 second vertical side 12 first horizontal side 13 and second horizontal side 14. First side 25 and second side 26 collectively form a substantially planer main body of towel 10. Towel 10 has a vertical axis A-A equidistant from first vertical side 11 and second vertical side 12. Towel 10 has a horizontal axis B-B equidistant from first horizontal side 13 and second horizontal side 14. Towel 10 may include periphery stitching 28 that is placed around the periphery of towel 10 along sides 11, 12, 13, and 14.

[0017] Towel 10 has a first opening 15 defined by outer opening border 16 inner opening border 17 lower opening border 18 and upper opening border 19. Opening 15 is parallel to first horizontal side 13 and configured such that opening 15 is relatively adjacent to second vertical side 12. Opening 15 may also include stitching 29 that may reinforce the integrity of the fabric bordering opening 15. Optionally, opening 15 may contain additional material along the periphery of opening 15 that may provide padding, or a decorative border.

[0018] Towel 10 has a second opening 20 defined by outer opening border 21 inner opening border 22 lower opening border 23 and upper opening border 24. Opening 20 is parallel to the second vertical side 12 and configured such that opening 20 is relatively adjacent to second vertical side 12. Opening 20 may also include stitching 27 that may reinforce the integrity of the fabric bordering opening 20. Optionally, opening 20 may contain additional material along the periphery of opening 20 that may provide padding, or a decorative border.

[0019] In an environment of use, as shown in FIG. 2, a user will place their entire arm through first opening 15, as shown in Step 1. Next, the user wraps towel 10 around their torso as shown in Step 2. The user will then place the same arm that had previously been placed through first opening 15, through second opening 20. Once the user has placed a single arm through each of first opening 15 and second opening 20, first side 25 will be facing away from the user and second side 26 will face the user.

[0020] While the invention has been described in its preferred form or embodiment with some degree of particularity, it is understood that this description has been given only by way of example and that numerous changes in the details of construction, fabrication, and use, including the combination and arrangement of parts, may be made without departing from the spirit and scope of the invention.

1. A towel easily wrapped and fixed about a body of a wearer, the towel comprising:

- a. a substantially planer rectangular main body having two substantially parallel horizontal edges and two substantially parallel vertical edges;
- b. at least two horizontally oriented openings in said main body.

2. (canceled)
3. The towel of claim 1 wherein said two openings are parallel to the horizontal edge.
4. The towel of claim 1 wherein said two openings are parallel and adjacent to the horizontal edge.
5. The towel of claim 1 wherein said two openings are positioned equidistant relative to placement on the main body to a horizontal axis.
6. The towel of claim 1 wherein said two openings are congruently positioned relative to placement on the main body to a vertical axis.
7. The towel of claim 1 wherein said two openings are congruent relative to their distance from each of their respective adjacent horizontal and vertical sides of said towel body.
8. A method for wearing a towel comprising the steps of:
 - a. providing a towel according to claim 1;
 - b. placing one arm in a first opening;
 - c. wrapping the towel around the body of the wearer;
 - d. securing the terminal side into a fixed position by placing the same arm from step b in a second opening.
9. (canceled)
10. A towel easily wrapped and fixed about a body of a wearer, the towel consisting of:
 - a. a substantially planer rectangular main body;
 - b. two horizontally oriented openings in said main body; wherein said two openings are parallel and adjacent to a horizontal edge of said main body, and further wherein said two openings are positioned equidistant relative to a horizontal axis, and congruent relative to a vertical axis.

* * * * *