

(19) **DANMARK**

(10) **DK/EP 3832363 T3**



(12) **Oversættelse af  
europæisk patentskrift**

Patent- og  
Varemærkestyrelsen

- 
- (51) Int.Cl.: **G 02 B 6/02 (2006.01)** **C 03 B 37/012 (2006.01)** **C 03 B 37/027 (2006.01)**
- (45) Oversættelsen bekendtgjort den: **2025-02-10**
- (80) Dato for Den Europæiske Patentmyndigheds bekendtgørelse om meddelelse af patentet: **2025-01-29**
- (86) Europæisk ansøgning nr.: **19213094.6**
- (86) Europæisk indleveringsdag: **2019-12-03**
- (87) Den europæiske ansøgnings publiceringsdag: **2021-06-09**
- (84) Designerede stater: **AL AT BE BG CH CY CZ DE DK EE ES FI FR GB GR HR HU IE IS IT LI LT LU LV MC MK MT NL NO PL PT RO RS SE SI SK SM TR**
- (73) Patenthaver: **ASML Netherlands B.V., P.O. Box 324, 5500 AH Veldhoven, Holland**
- (72) Opfinder: **BAUERSCHMIDT, Sebastian, Thomas, P.O. Box 324, 5500 AH Veldhoven, Holland**  
**NIU, Mingli, P.O. Box 324, 5500 AH Veldhoven, Holland**
- (74) Fuldmægtig i Danmark: **Murgitroyd & Company, Mannerheimvägen 12 B, 5:e våningen, FI-00100 Helsingfors, Finland**
- (54) Benævnelse: **En enhed og metode til at forbinde en fiberpræform til et trykforsyningssystem**
- (56) Fremdragne publikationer:  
**US-A1- 2001 038 740**  
**US-A1- 2003 230 118**  
**US-A1- 2011 121 474**  
**US-A1- 2018 339 931**  
**US-B2- 7 793 521**



# DESCRIPTION

Description

## FIELD

**[0001]** The present invention relates to a device and method for connecting a fibre preform including a plurality of elongate holes extending substantially parallel to a longitudinal axis of the fibre preform to a pressure supply system.

## BACKGROUND

**[0002]** Solid-core fibres are generally known and broadly used e.g. in data communication applications. Solid-core fibres can be designed for low-loss, single-mode transmission in a broadband transmission range of the fibre material, like quartz glass. So-called endlessly single-mode guidance (ESM, i.e. all higher order modes, HOMs, are leaky while the fundamental  $LP_{01}$  mode is fully confined) is achieved in solid-core photonic crystal fibres (PCFs) by engineering a cladding structure surrounding the solid-core, as shown in Figure 1A (prior art), such that the diameter  $d$  of channels in the cladding structure and their centre-centre spacing (pitch)  $\Lambda$  fulfils the geometrical condition  $d/\Lambda < 0.41$ . However, due to light guiding in the solid fibre material, disadvantages exist in terms of increased latency in data transmission, optically non-linear effects resulting in new light frequencies, and relatively low damage thresholds.

**[0003]** Through their ability to guide light in a non-solid core region, which is evacuated (vacuum core), filled with a gas or filled with a liquid, hollow-core photonic crystal fibres, HC-PCFs, have unique advantages compared to solid-core fibres, resulting in application areas such as low-latency data transmission, high-power beam delivery, gas-based nonlinear optics, light guiding with ultralow nonlinearities and chemical sensing. HC-PCFs are typically divided into two classes depending on the physical guidance mechanism: hollow-core photonic bandgap fibres (HC-PBFs) and hollow-core anti-resonant-reflecting fibres (HC-AFs).

**[0004]** Figures 1B to 1I (prior art) shows a selection of scanning electron micrographs of different types of conventional HC-PCFs. Figures 1B and 1C show HC-PBFs that confine modes inside a central hollow core by means of a photonic bandgap in the cladding. These types of PCF typically have relatively low loss (ca.  $< 20$  dB/km) at telecommunication wavelengths. However, due to the wavelength-specific effect of the photonic bandgap, they guide light over a relatively narrow bandwidth (ca.  $< 15$  THz) only. Although in general HC-

PBFs support HOMs, it has been shown that banded HC-PBFs can be made effectively single-mode by including "satellite" hollow cores in the cladding (Fig. 1B). These satellites strongly suppress HOMs in the core by phase-matching to them, causing high HOM loss. HC-PBGs can also be made truly single-mode over a narrow spectral range (ca. < 7 THz) if a small enough core is used

**[0005]** (see Fig. 1C), but this results in fabrication difficulties and significantly higher loss for the desired fundamental mode.

**[0006]** Figures 1D to 1I show a selection of HC-AF structures, i.e. fibres having guidance mechanism based mostly on anti-resonant effects. Figures 1D and 1E have a Kagomé-lattice cladding and Figures 1F and 1G have one ring of single (F) or nested (G) anti-resonant elements (AREs). Figure 1H shows a HC-AF with a square core and Fig. 1I depicts a HC-AF with guiding properties in the ultraviolet. Compared to HC-PBFs, the loss of HC-AFs is in general larger because of the non-ideal confinement, but the transmission window is broader.

**[0007]** HC-PCFs are typically fabricated from glass preforms in a fibre drawing process. The transverse structure of these preforms resembles that of the final fibre material, i.e. a plurality of elongate holes extending substantially parallel to a longitudinal axis of the fibre preform in a well-defined pattern. During the drawing process, the transverse structure is scaled down from the original preform diameter, typically a few millimetres, to the diameter of the optical fibre, typically 100 to 500 micrometres. To prevent the elongate holes from collapsing during the fibre drawing process, they are pressurized, as for instance disclosed in EP 3 136 143 A1, US7,793,521B2, US2018/0339931A1 or US2003/0230118A1.

**[0008]** A drawback of the current drawing process is that connecting plurality of elongate holes to a pressure supply system is a complicated and time intensive process

## SUMMARY

**[0009]** Considering the above, it is an object of the invention to provide a device and method for connecting a fibre preform to a pressure supply system in an easy and quick manner.

**[0010]** According to the claimed invention, there is provided a device for connecting a fibre preform including a plurality of elongate holes extending substantially parallel to a longitudinal axis of the fibre preform to a pressure supply system, said device comprising:

1. a. a first surface to be connected to an end face of the fibre preform where the plurality of elongate holes end;
2. b. a second surface comprising at least two ports configured to be in fluid connection with the pressure supply system; and
3. c. a channel system within the device connecting the plurality of elongate holes at the first surface to the at least two ports such that at least one of the plurality of elongate

holes is connected to one of the at least two ports and such that at least one other of the plurality of elongate holes is connected to another one of the at least two ports,

wherein a density of the at least two ports at the second surface is smaller than a corresponding density of the channel system at the first surface, characterised in that the device comprises a bottom device portion an intermediate device portion and a top device portion, wherein the device has a cylindrical shape with a longitudinal axis so that the bottom device portion, the intermediate device portion and the top device portion form cylindrically shaped segments stacked upon each other to form the device.

**[0011]** By providing a device with an integrated channel system and a first surface to be connected to an end face of the fibre preform, complex structures of the fibre preform as for instance disclosed in US 2011/0121474 A1 where tubes having different lengths extending from the end face are used, and time intensive operations such as connecting pressure tubes to the elongate holes as disclosed in US 2019/0135679 A1, can be avoided. The density of the at least two ports at the second surface being smaller than a corresponding density of the channel system at the first surface may have the advantage that more space is provided at the second surface for connecting the at least two ports to the pressure supply system and for instance conventional connectors may be used.

**[0012]** In an embodiment of the invention, the second surface includes a first surface portion substantially opposite the first surface and a second surface portion extending substantially non-parallel to the first surface, and wherein at least one port is arranged at the first surface portion of the second surface and at least one other port is arranged at the second surface portion of the second surface. This may provide more space between the at least two ports as the ports are arranged at surface portions that extend in different directions and thus have a different orientation.

**[0013]** In an embodiment of the invention, the end face of the fibre preform has a circular shape with a centre and a radius, wherein the device has a longitudinal axis to coincide with the centre of the fibre preform, wherein the second surface includes a first surface portion substantially opposite the first surface and a second surface portion extending substantially perpendicular to the first surface, and wherein at least one port is arranged at the second surface portion of the second surface at a distance from the longitudinal axis of the device that is larger than the radius of the fibre preform.

**[0014]** The fibre preform typically has a radius in the range of a few millimetres. By arranging the second surface portion at a larger distance from the longitudinal axis of the device than the radius of the fibre preform, more space can be made available for connecting ports to the pressure supply system.

**[0015]** In an embodiment of the invention, the device has a cylindrical shape with the first surface being an end surface of the cylindrical shape, wherein the second surface includes a first surface portion being an end surface of the cylindrical shape opposite the first surface and

a second surface portion being a side surface of the cylindrical shape. Preferably, the cylindrical shape corresponds to a right circular cylinder or a right elliptic cylinder.

**[0016]** In an embodiment of the invention, the first surface is provided with one or more nozzles to mate with corresponding tubular elements in the fibre preform forming elongate holes. An advantage of nozzles may be that sealing between an elongate hole and the channel system is improved and/or that the mechanical robustness is improved and/or that the alignment process between first surface of the device and the end face of the fibre preform is simplified.

**[0017]** In an embodiment of the invention, the channel system at a distance from the first surface occupies a cross-sectional area that is larger than a cross-sectional area occupied by the channel system at the first surface. Such a diverging channel system allows to easily create additional space for connecting the at least two ports to the pressure supply system.

**[0018]** In an embodiment of the invention, the intermediate device portion has one or more of the following features:

1. a. a port at a side surface of the intermediate device portion;
2. b. one or more unbranched channels extending through the intermediate device portion;
3. c. channels that are combined into a single channel;
4. d. one or more channels that are tapered or otherwise having a changing cross-section, e.g. such that a size of a cross-section of the one or more channels increases towards a top device portion side of the intermediate device portion,

and wherein the bottom device portion includes the first surface.

**[0019]** The above mentioned feature a. allows for an easy to fabricate port at a side surface of the device by incorporating the port in an intermediate device portion. Such a port may for instance be fabricated as an opening extending over the entire height of the intermediate device that is delimited at the bottom and top side by the adjacent device portions.

**[0020]** The above mentioned feature c. allows channels that need to be pressurized with the same pressure to be combined to reduce the number of ports necessary to connect the fibre preform to the pressure supply system.

**[0021]** The above mentioned feature d. allows for instance to increase the cross-section of the channels to match the size of a port or connection to the pressure supply system.

**[0022]** In an embodiment of the invention, the top device portion includes a port arranged at a side surface of the top device portion and/or a port arranged at a surface facing away from the at least one intermediate device portion.

**[0023]** According to a further embodiment of the invention as defined by appended claim 10, there is provided a method for connecting a fibre preform including a plurality of elongate holes

extending substantially parallel to a longitudinal axis of the fibre preform to a pressure supply system, said method comprising the following steps:

1. a. attaching an end face of the fibre preform where the plurality of elongate holes end to a first surface of a device according to the invention; and
2. b. connecting the at least two ports to the pressure supply system.

**[0024]** In an embodiment of the invention, the end face of the fibre preform is attached to the first surface of the device using a sealant to provide a substantially gas-tight connection between elongate holes in the fibre preform and the channel system of the device.

**[0025]** In an embodiment of the invention, the method comprises the following steps:

1. i. prior to step a., inserting a temporary blocking member into one or more elongate holes in the fibre preform, which temporary blocking member is configured to prevent blocking of a passage between the corresponding elongate hole and the channel system of the device during step a.; and
2. ii. during or after step a., removing the temporary blocking member.

## **BRIEF DESCRIPTION OF THE DRAWINGS**

**[0026]** Embodiments of the invention will now be described, by way of example only, with reference to the accompanying schematic drawings, in which:

- Figure 1 depicts cross-sections of conventional solid or hollow core fibres (prior art);
- Figure 2 schematically depicts a connection between a fibre preform and a pressure supply system;
- Figure 3 schematically depicts an exploded view of a device according to an embodiment of the invention and a fibre preform;
- Figure 4 schematically depicts a cross-sectional view of the device of Fig. 3; and
- Figure 5 schematically depicts a cross-sectional view of a device according to another embodiment of the invention.

## **DETAILED DESCRIPTION**

**[0027]** Fig. 2 schematically depicts a fibre preform FP including a plurality of elongate holes extending substantially parallel to a longitudinal axis LA for instance similar to any of the shown

examples B-I in Fig. 1. The plurality of elongate holes end at an end face of the preform FP as for instance shown in Fig. 1 for the examples B-I.

**[0028]** Fig. 2 schematically depicts how the fibre preform FP is connected to a pressure supply system PSS. To this end a device D is provided according to the invention, examples of which will be explained below in more detail. The device D includes a first surface FS connected to an end face of the fibre preform FP where the plurality of elongate holes end, and a second surface including a first surface portion FSP substantially opposite the first surface FS and a second surface portion SSP extending between the first surface FS and the first surface portion FSP.

**[0029]** Arranged at the first surface portion FSP is a first port P1 connected to the pressure supply system PSS via a first fluid communication line FL1. Arranged at the second surface portion SSP is a second port P2 connected to the pressure supply system PSS via a second fluid communication line FL2. At least one of the plurality of elongate holes of the fibre preform FP is connected to the first port P1 while at least one other of the plurality of elongate holes is connected to the second port P2 via channel system within the device D examples of which will be explained below in more detail. As a result of the channel system, the two ports P1, P2 and the two fluid communication lines FL1, FL2, it is possible to use the pressure supply system to provide different pressures to different elongate holes.

**[0030]** According to the invention, the density of the two ports P1, P2 at the second surface is smaller than a corresponding density of the channel system at the first surface as will be explained below in more detail.

**[0031]** Exemplary embodiments of the device D suitable to be used in the embodiment of Fig. 2 will be described by reference to the Figs. 3-5.

**[0032]** Figs. 3 and 4 schematically depict an exploded view and a cross-sectional view of a device D according to an embodiment of the invention and a fibre preform FP, respectively. The fibre preform FP is schematically depicted as an outer tube OT encompassing four smaller inner tubes IT. As a result thereof, the preform FP includes five elongate holes H1-H5, namely four elongate holes H1-H4 corresponding to the four inner tubes IT, respectively, and the elongate hole H5 corresponding to the space inside the outer tube OT in between the four inner tubes IT.

**[0033]** The fibre preform FP has a cylindrical shape, at least near the device D, defined by a side wall SW of the outer tube OT and delimited at one end by an end face EF, which end face EF is also a face where the elongate holes H1-H5 end. The end face EF thus has a circular shape with a centre coinciding with a longitudinal axis LA of the preform FP and a radius R.

**[0034]** The end face EF of the preform FP is connected to the device D. As can be clearly seen in the exploded view of Fig. 3, the device D includes a bottom device portion BD, an intermediate device portion ID, and a top device portion TD. The device D has a cylindrical

shape with a longitudinal axis DLA, so that the device portions BD, ID, TD form cylindrically shaped segments stacked upon each other to form the device D.

**[0035]** The bottom device portion BD includes a first surface FS connected to the end face EF of the fibre preform FP, e.g. using a sealant to provide a substantially gas-tight connection. The top device portion TD includes a first surface portion FSP opposite to the first surface FS, which first surface portion FSP is part of a second surface of the device D. The device portions BD, ID, TD all include a portion of a second surface portion SSP extending between the first surface SP at the bottom device portion BD and the first surface portion FSP and being part of the second surface of the device D.

**[0036]** The second surface of the device D comprises a first port P1 and a second port P2 to connect the device D to a pressure supply system. In this embodiment, the first port P1 is arranged at the first surface portion FSP and the second port P2 is arranged at the second surface portion SSP.

**[0037]** The first surface FS of the device D includes an opening O per elongate hole H1-H5, which five openings O are connected to the first port P1 or the second port P2 via five corresponding channels of a channel system of which only the channels CH1, CH3 and CH5 are visible in Fig. 4.

**[0038]** The openings O associated with the inner tubes IT are in this embodiment provided with nozzles N to make alignment with the holes H1-H4 easy and to provide a gas-tight connection. The corresponding channels CH1, CH3, extend from the bottom device portion BD through the intermediate device portion ID to the top device portion TD to be combined into a single channel SCH connected to the first port P1. The channel CH5 extends from the bottom device portion BD to the intermediate device portion ID where it is connected to the second port P2. Hence, as a result, by applying different pressures to the first and second ports P1, P2, the pressure in the inner tubes IT can be different from the pressure in the hole H5.

**[0039]** It will be clear to the skilled person that a distance between the first port P1 and the second port P2 at the second surface of the device D can be larger than a distance between the openings O at the first surface FS of the device D. In other words, by having a density of the ports at the second surface that is smaller than a density of the channel system at the first surface FS, space is created to connect the first and second ports P1, P2 to a pressure supply system.

**[0040]** Fig. 5 depicts a cross-sectional view of a device D according to another embodiment of the invention connected to the same fibre preform FP as in the embodiment of Figs. 3 and 4. To avoid unduly repetition, similar reference symbols are used to indicate similar parts of the device D and the description below focuses on the differences between the two embodiments, so that the description relating to the embodiment of Figs. 3 and 4 also applies to the embodiment of Fig. 5 as well for the similarities.

**[0041]** A main difference between the shown embodiments is that the device D in Fig. 5 has a cylindrical shape with a radius DR that is larger than the radius R of the fibre preform FP. As a result thereof, more surface area at the second surface of the device D is available for ports, such as the first port P1 and the second port P2, allowing to increase the number of ports while substantially keeping the same density of ports or to increase the size of the ports or use larger connectors to connect the ports to the pressure supply system.

**[0042]** As the end face EF of the fibre preform FP is smaller than the first surface FS of the bottom device portion BD, the openings O of the channel system are arranged around a centre of the first surface FS and do not cover the entire first surface FS. The channels CH1-CH5 of the channel system in the bottom device portion BD can diverge towards the intermediate device portion ID and/or taper outwards towards the intermediate device portion ID, so that a size of a cross-section of the one or more channels CH1-CH5 increases towards a top device portion side of the bottom device portion BD. The intermediate device portion ID and the top device portion TD have a similar construction compared to the embodiment of Figs. 3 and 4, but with increased dimensions.

**[0043]** Although the above embodiments have been described with a limited number of elongate holes in the fibre preform, a limited number of ports, and a limited number of device portions to keep the examples simple and easy to understand, it will be clear for the skilled person that any practical number of elongate holes, e.g. as shown in examples 1B-11, in the fibre preform, any practical number of ports, depending on the pressure requirements during the drawing process, and any practical number of device portions, if necessary, can be used.

**[0044]** Although the above embodiments describe the device D as being modular and being made of a plurality of device portions, it is possible to use a single component device D as well. Such a device D can for instance be manufactured using 3D printing techniques.

**[0045]** The features of the invention disclosed in the above description, the drawings and the claims can be of significance individually, in combination or sub-combination for the implementation of the invention in its different embodiments.

**[0046]** While specific embodiments of the invention have been described above, it will be appreciated that the invention may be practiced otherwise than as described. The descriptions above are intended to be illustrative, not limiting. Thus it will be apparent to one skilled in the art that modifications may be made to the invention as described without departing from the scope of the claims set out below.

## **REFERENCES CITED IN THE DESCRIPTION**

Cited references

This list of references cited by the applicant is for the reader's convenience only. It does not form part of the European patent document. Even though great care has been taken in compiling the references, errors or omissions cannot be excluded and the EPO disclaims all liability in this regard.

**Patent documents cited in the description**

- [EP3136143A1 \[0007\]](#)
- [US7793521B2 \[0007\]](#)
- [US20180339931A1 \[0007\]](#)
- [US20030230118A1 \[0007\]](#)
- [US20110121474A1 \[0011\]](#)
- [US20190135679A1 \[0011\]](#)

## PATENTKRAV

1. Anordning (D) til at forbinde en fiberpræform (FP), der indbefatter en flerhed af aflange huller (H1, H2, H3, H4, H5), der strækker sig i det væsentlige parallelt med  
5 længdeaksen (LA) af fiberpræformen (FP), til et trykforsyningssystem (PSS), hvilken anordning (D) omfatter:
- a. en første overflade (FS) til at blive forbundet til en endeflade (EF) af fiberpræformen (FP), hvor flerheden af aflange huller (H1, H2, H3, H4, H5) ender;
  - b. en anden overflade (FSP, SSP), der omfatter mindst to porte (P1, P2), der er  
10 konfigureret til at være i fluidforbindelse med trykforsyningssystemet (PSS); og
  - c. et kanalsystem (CH1, CH3, CH5) i anordningen (D), der forbinder flerheden af aflange huller (H1, H2, H3, H4, H5) i den første overflade (FS) til de mindst to porte (P1, P2), således at mindst ét af flerheden af aflange huller (H1, H2, H3, H4, H5) er forbundet til én af de mindst to porte (P1, P2), og således at mindst én  
15 anden af flerheden af aflange huller (H1, H2, H3, H4, H5) er forbundet til en anden af de mindst to porte (P1, P2),
- hvor tætheden af de mindst to porte (P1, P2) i den anden overflade (FSP, SSP) er mindre end en tilsvarende tæthed af kanalsystemet (CH1, CH3, CH5) i den første overflade (FS),
- 20 hvor anordningen (D) omfatter en bund-anordningsdel (BD), en mellem-anordningsdel (ID) og en top-anordningsdel (TD), og ved at anordningen (D) har en cylindrisk form med en længdeakse (DLA), således at bund-anordningsdelen (BD), mellem-anordningsdelen (ID) og top-anordningsdelen (TD) danner cylindrisk formede segmenter, der er stakket oven på hinanden til frembringelse af anordningen (D).
- 25
2. Anordning ifølge krav 1, hvor den anden overflade (FSP, SSP) indbefatter en første overfladedel (FSP), der er i det væsentlige modsat den første overflade (FS), og en anden overfladedel (SSP), der udgår i det væsentlige ikke-parallelt med den første overflade (FS), og hvor mindst én port er anbragt i den første overfladedel (FSP) af den  
30 anden overflade (FSP, SSP), og mindst én anden port er anbragt i den anden overfladedel (SSP) af den anden overflade (FSP, SSP).
3. Anordning (D) ifølge krav 1 eller 2, hvor endefluden (EF) af fiberpræformen (FP) har en cirkulær form med et midtpunkt og en radius (R), hvor længdeaksen (DLA) af  
35 anordningen (D) er sammenfaldende med midtpunktet i fiberpræformen (FP), hvor den anden overflade (FSP, SSP) indbefatter den første overfladedel (FSP), der er i det væsentlige modsat den første overflade (FS), og den anden overfladedel (SSP), der strækker sig i det væsentlige vinkelret på den første overflade (FS), og

hvor mindst én port (P1, P2) er anbragt i den anden overfladedel (SSP) af den anden overflade (FSP, SSP) i en afstand fra længdeaksen (LA) af anordningen (D), der er større end radius (R) af fiberpræformen (FP).

- 5 4. Anordning (D) ifølge et hvilket som helst af kravene 1-3, hvor anordningen (D) har den cylindriske form, idet den første overflade (FS) er en endeoverflade af den cylindriske form, hvor den anden overflade (FSP, SSP) indbefatter en første overfladedel (FSP), der er en endeoverflade af den cylindriske form modsat den første overflade (FS), og en anden overfladedel (SSP), der er en sideoverflade af den cylindriske form.
- 10 5. Anordning (D) ifølge krav 4, hvor den cylindriske form svarer til en ret cirkulær cylinder eller en ret ellipsoformet cylinder.
6. Anordning (D) ifølge et hvilket som helst af kravene 1-5, hvor den første overflade (FS) er forsynet med en eller flere dyser (N), der passer ind i tilsvarende rørformede elementer (IT) i fiberpræformen (FP), der danner aflange huller (H1, H2, H3, H4, H5).
- 15 7. Anordning (D) ifølge et hvilket som helst af kravene 1-6, hvor kanalsystemet (CH1, CH3, CH5) i en afstand fra den første overflade (FS) dækker et tværsnitsareal, der er større end et tværsnitsareal, der dækkes af kanalsystemet (CH1, CH3, CH5) i den første overflade (FS).
- 20 8. Anordning (D) ifølge krav 1, hvor mellem-anordningsdelen (ID) har en eller flere af følgende træk:
- 25 a. en port (P2) i en sideoverflade af mellem-anordningsdelen (ID);
- b. en eller flere uforgrenede kanaler, der strækker sig gennem mellem-anordningsdelen (ID);
- c. kanaler, der kombineres i en enkelt kanal;
- d. en eller flere kanaler, der er tilspidset, f.eks. således at størrelsen af et tværsnit af den ene eller de flere kanaler stiger mod en top-anordningsdel (TD)-side af mellem-anordningsdelen (ID);
- 30 og hvor bund-anordningsdelen (BD) indbefatter den første overflade (FS).
9. Anordning (D) ifølge krav 8, hvor top-anordningsdelen (TD) indbefatter en port (P2), der er anbragt i en sideoverflade af top-anordningsdelen (TD), og/eller en port (P1), der er anbragt i en overflade, der vender væk fra den mindst ene mellem-anordningsdel (ID).
- 35 10. Fremgangsmåde til forbindelse af en fiberpræform (FP), der indbefatter en flerhed af

aflange huller (H1, H2, H3, H4, H5), der strækker sig i det væsentlige parallelt med en længdeakse (LA) af fiberpræformen (FP), til et trykforsyningssystem (PSS), hvilken fremgangsmåde omfatter følgende trin:

- 5 a. fastgørelse af en endeflade (EF) af fiberpræformen (FP), hvor flerheden af aflange huller (H1, H2, H3, H4, H5) ender, til en første overflade (FS) af en anordning (D) ifølge et hvilket som helst af kravene 1-9; og
  - b. forbindelse af de mindst to porte (P1, P2) til trykforsyningssystemet (PSS).
11. Fremgangsmåde ifølge krav 10, hvor endefladen (EF) af fiberpræformen (FP) fastgøres til den første overflade (FS) af anordningen (D) ved anvendelse af et forseglingsmiddel til tilvejebringelse af en i det væsentlige gastæt forbindelse mellem aflange huller (H1, H2, H3, H4, H5) i fiberpræformen (FP) og kanalsystemet (CH1, CH3, CH5) i anordningen (D).
- 15 12. Fremgangsmåde ifølge krav 10 eller 11, hvor fremgangsmåden omfatter følgende trin:
- 20 i. før trin a., indsættelse af en midlertidig blokeringsdel i en eller flere aflange huller (H1, H2, H3, H4, H5) i fiberpræformen (FP), hvilken midlertidige blokeringsdel er konfigureret til at forhindre blokering af passage mellem de tilsvarende aflange huller (H1, H2, H3, H4, H5) og kanalsystemet (CH1, CH3, CH5) i anordningen (D) i løbet af trin a.; og
  - ii. i løbet af eller efter trin a., fjernelse af den midlertidige blokeringsdel.
- 25 13. Fremgangsmåde ifølge krav 12, hvor anordningen (D) er en anordning (D) ifølge et hvilket som helst af kravene 1-9, hvor trin a. indbefatter et trin med fastgørelse af endefladen (EF) af fiberpræformen (PF) til en anordningsdel (BD), der indbefatter den første overflade (FS), og hvor trin ii. udføres ved hjælp af anordningsdelen (BD), der indbefatter den første overflade (FS), og før andre anordningsdele (TD, ID) forbindes til anordningsdel (BD), der indbefatter den første overflade (FS).

# DRAWINGS

Drawing

FIG. 1

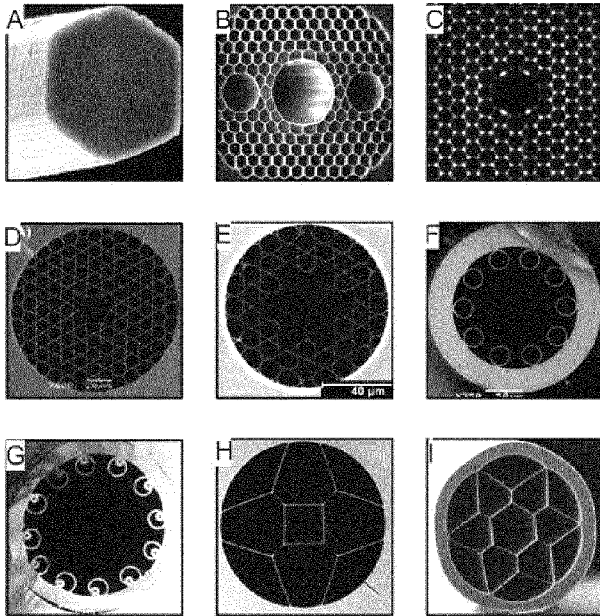
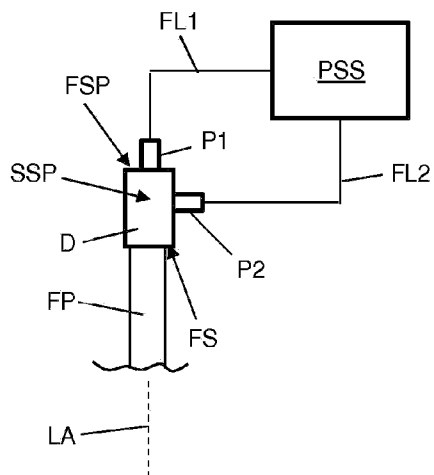

FIG. 2



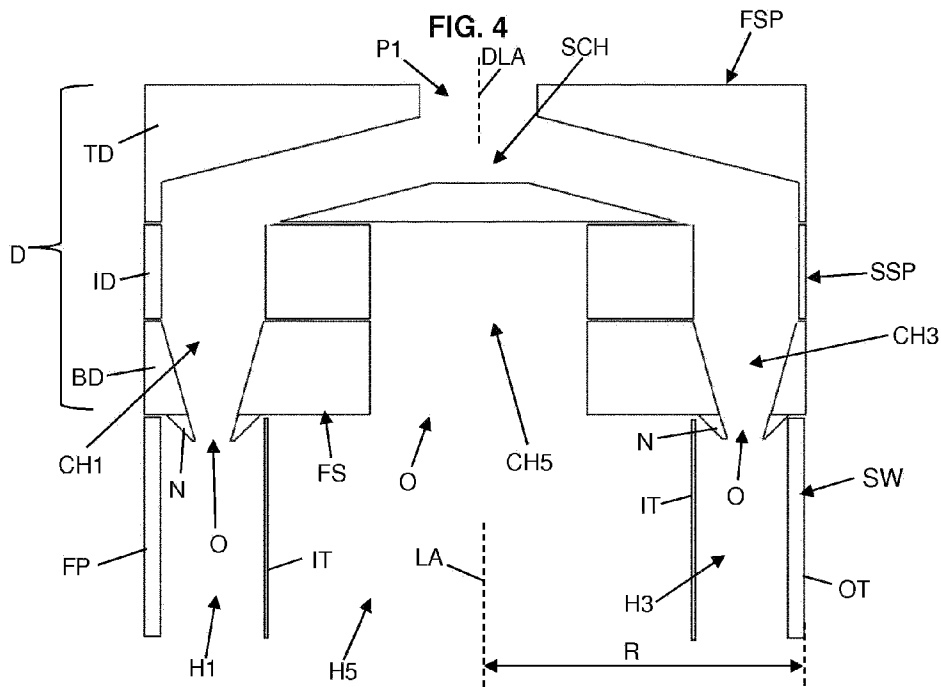
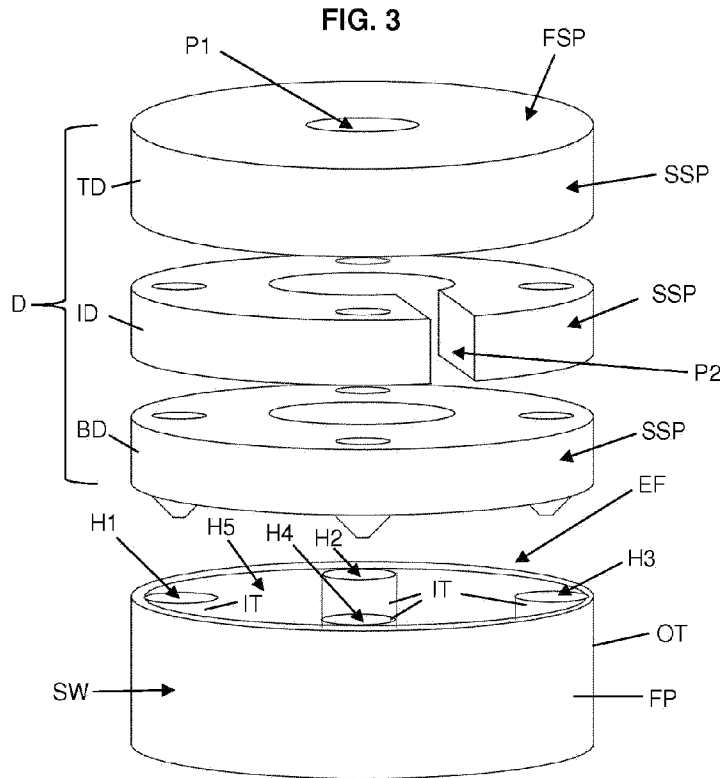

FIG. 5

