

(19) World Intellectual Property Organization  
International Bureau



(43) International Publication Date  
7 November 2002 (07.11.2002)

PCT

(10) International Publication Number  
**WO 02/088475 A1**

- (51) International Patent Classification<sup>7</sup>: E02D 27/52, F03D 11/04, B63B 21/27, 21/50
- (74) Agent: ASSEDELFT, Jacobus, Hendrikus, Wilhelmus; Keukenhofdreef 20, NL-2161 AZ Lisse (NL).
- (21) International Application Number: PCT/NL02/00283
- (81) Designated States (*national*): AE, AG, AL, AM, AT, AU, AZ, BA, BB, BG, BR, BY, BZ, CA, CH, CN, CO, CR, CU, CZ, DE, DK, DM, DZ, EC, EE, ES, FI, GB, GD, GE, GH, GM, HR, HU, ID, IL, IN, IS, JP, KE, KG, KP, KR, KZ, LC, LK, LR, LS, LT, LU, LV, MA, MD, MG, MK, MN, MW, MX, MZ, NO, NZ, PL, PT, RO, RU, SD, SE, SG, SI, SK, SL, TJ, TM, TR, TT, TZ, UA, UG, US, UZ, VN, YU, ZA, ZW.
- (22) International Filing Date: 26 April 2002 (26.04.2002)
- (25) Filing Language: Dutch
- (26) Publication Language: English
- (30) Priority Data:  
1017946 26 April 2001 (26.04.2001) NL  
1018109 18 May 2001 (18.05.2001) NL  
1018110 18 May 2001 (18.05.2001) NL
- (84) Designated States (*regional*): ARIPO patent (GH, GM, KE, LS, MW, MZ, SD, SL, SZ, TZ, UG, ZW), Eurasian patent (AM, AZ, BY, KG, KZ, MD, RU, TJ, TM), European patent (AT, BE, CH, CY, DE, DK, ES, FI, FR, GB, GR, IE, IT, LU, MC, NL, PT, SE, TR), OAPI patent (BF, BJ, CF, CG, CI, CM, GA, GN, GW, ML, MR, NE, SN, TD, TG).
- (71) Applicant (*for all designated States except US*): SUC-TION PILE TECHNOLOGY B.V. [NL/NL]; Korenmolenlaan 2, NL-3447 GG Woerden (NL).
- (72) Inventor; and
- (75) Inventor/Applicant (*for US only*): RIEMERS, Mark, Erik [NL/NL]; Korenmolenlaan 2, NL-3447 GG Woerden (NL).

**Published:**

- with international search report
- before the expiration of the time limit for amending the claims and to be republished in the event of receipt of amendments

[Continued on next page]

(54) Title: MARINE STRUCTURE

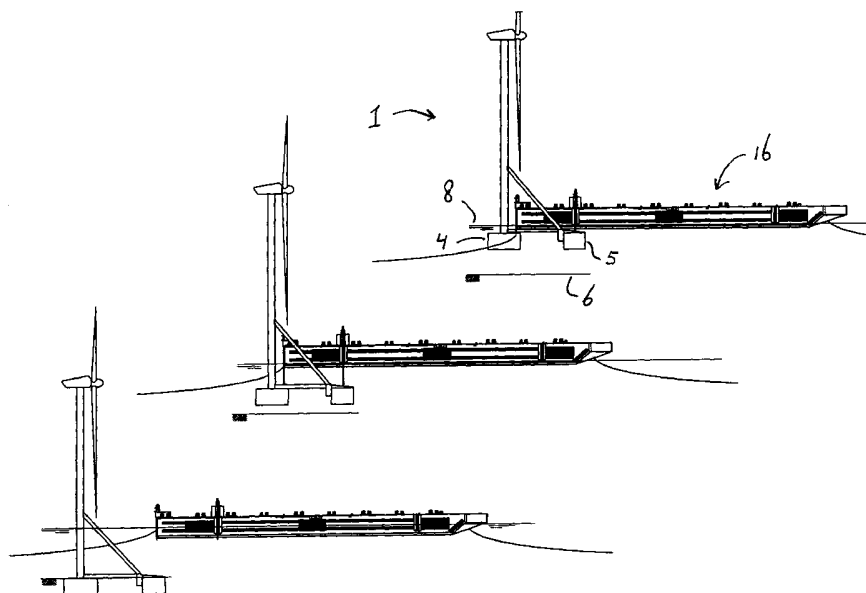

(57) Abstract: Marine structure (1) with a foundation part (2) and an upper structure (3) extending therefrom upward, wherein said foundation part has at least one suction pile (4, 5) designed to at least partly penetrate the subsea bottom during installation; at least substantially in its operating position connected to a vessel (16) to be below or aside it to be transported over water in an orientation such that the structure from its position mounted to the vessel can be immediately lowered onto the subsea bottom while suspending from a flexible pulling element of the vessel and in a stable balanced position.



WO 02/088475 A1



---

*For two-letter codes and other abbreviations, refer to the "Guidance Notes on Codes and Abbreviations" appearing at the beginning of each regular issue of the PCT Gazette.*

## Marine structure

Suction piles and their way of installing are o.a. known from GB-B-2300661 and EP-B-0011894, which disclosures are enclosed here by reference. Briefly, a suction pile is a thin walled steel cylinder, closed at at least one longitudinal end, that is located on the subsea bottom with the opposite end and penetrates the subsea bottom with the aid of a suction created within the cylinder. The creation of the suction can be with the aid of a suction source, such as a pump, being on, or close to or at a distance (e.g. above the water surface, e.g. at a vessel) from the suction pile. The applied level of the suction can be e.g. at least substantially constant, smoothly increase or decrease or else pulsate, for which there are convenient means; for an e.g. pulsating level a possibly in the suction pile integrated pressure accumulator that is intermittently connected to the inner space of the cylinder. After use, the suction pile can easily be removed by creating an overpressure within the cylinder, e.g. by pumping in (seawater). Thus the required equipment voor installing and removing a suction pile is substantially less elaborated, complicated and costly compared to the use of ram piles, for which a.o. an under water ramming system is required.

The object of the invention is a simplified method for installing a marine structure resting on the under water surface, possibly projecting above the water surface. Therefore this marine structure has a foundation part and an upper structure part extending upward therefrom, wherein said foundation part has at least one suction pile adapted to at least partially penetrate the bottom during installing, and wherein preferably said upper structure part has a dimension sufficient such that after the marine structure is installed at the operation location, it projects above the water surface and/or contains a device, such as a wind or water turbine or an oil or gas production platform with e.g. helicopter deck. This marine structure is at least substantially in its operating position fixed to a floating transport device or vessel, such as a pontoon or barge, to be transported over water. For

said transport and the subsequent installing procedure measurements are taken such that said marine structure is positioned at least partly next to or below the vessel in an orientation such that said marine structure from its fixed position to the vessel can be lowered onto the subsea bottom, while suspending from at least one flexible pulling means extending from said vessel and in a stable balanced position. This balance position is obtained by convenient locating of the centre of gravity of the marine structure, such as keeping it in a tilted position relevant to its operating position and/or by using ballast.

In that way the marine structure can be lowered onto the subsea bottom without the requirement to initially being tilted and/or upward and/or sideways translated relevant to the vessel. Thus cost, time, energy, environment and material savings are possible and also the work can be safer.

In the annexed drawing the presently most preferred embodiments are shown for illustrative purposes.

Fig. 1 and 2 show the first embodiment in a side and top view, installed onto the subsea bottom.

Fig. 3 and 4 show the second embodiment in the views according to fig. 1 and 2;

Fig. 5 and 6 show a side and top view of the way in which the marine structure is fixed to the vessel to be transported and installed;

Fig. 7 shows a side view of the installation procedure from a vessel;

Fig. 8 shows a side view of the installation procedure from a vessel in less deep water; and

Fig 9 and 10 show a side and top view of a variant to the embodiment of fig. 5 and 6.

Fig. 1 and 2 show a marine structure 1 with a foundation part 2 and a upper structure part 3. The foundation part 2 has at least one, preferably at least two, such as in this example three mutually spaced suction piles 4, 5. The upper structure part 3 extends preferably at least substantially completely above the suction pile 4, which has preferably a substantially larger bearing or anchoring capacity within the subsea bottom

related to the two other suction piles 5. In this embodiment this is obtained in that the suction pile 4 has a substantial, preferably at least 25% increased diameter. It is feasible that all suction piles 4, 5 have an at least substantially equal dimension, or that at least one suction pile has a larger dimension, preferably diameter, than at least one other suction pile.

The upper structure part 3 has preferably an elongated body 7 that preferably projects far above the water surface 8 after installation on the subsea bottom. For application with an oil/gas platform the body 7 projects e.g. at least 5 m, preferably at least 10 m, most preferably at least 20 m above the water surface. For application with a wind turbine the body 7 e.g. projects at least 20 m, more preferably at least 30 m, most preferably at least 60 m above the water surface. This body 7 is preferably column shaped. In this example the body 7 is a bending and torsion rigid tube or pile with a diameter of preferably at least about 0,75 m, more preferably at least 1 m, such as at least about 2 m. In an alternative the body 7 can contain a space frame structure.

The elongated body 7 is preferably mounted on top of the suction pile 4. At a distance above the lower side of the body 7 it preferably has mounted stay or brace elements. These elements 11 are with their opposite end mounted to a relevant suction pile 5. With these elements 11 at least a part of the bending and/or torsion load in the body 7 is beared by the suction piles 5. These elements 11 can be flexibel, e.g. a cable or chain, such that they can only bear pulling loads from the body 7. Preferably they are however buckle rigid, e.g. a tube, such that they can bear pulling and compression loads from the body 7. Although the drawings show that these elements 11 extend according to an inclined straight line relevant to the body 7, another arrangement is feasible, e.g. buckled or bent in at least one location. It is also feasible that (not illustrated) preferably elongated buckle stiffeners, such as a rod or cable, are mounted to an element 11 in at least one position between its ends and to e.g. the body 7 or the suction pile 4 or some other element of the foundation

part 2 or upper structure part 3.

Preferably horizontal pull and/or compression rigid rod like elements 12 extend between the suction piles 4, 5. Their object is a.o. to keep the suction piles 4, 5 at the desired spacing during transport over water and lowering onto the subsea bottom. At least one of these elements 12 could be removed or replaced by an alternative structure with similar function. The element 12 extending between the suction piles 5 with smaller diameter is easiest to remove or replace. A brace 11 is positioned right above a tube 12, such that two tubes 12 in fig. 2 are covered by one brace 11 each time.

The upper structure part 3 carries a wind turbine 9 of a type known as such, in this embodiment with horizontal rotation axis and at least one wind driven blade 10 mounted thereto, wherein the rotation axis can be swiveled around an upright axis to orientate the blade 10 relevant to the wind. In this embodiment the wind turbine 9 can be swiveled around the longitudinal axis of the body 7.

The marine structure 1 has a relatively large dimension and will accordingly have a weight typically at least 30,000 kg. For a marine structure 1 which remains completely under water, the weight will be about 50,000 kg or more. For a structure 1 extending above the water the weight will be about 100,000 kg or more.

The marine structure 1 is equipped with at least one, preferably at least two, most preferably at least three mutually spaced hoisting points 13, wherein in top view those hoisting points 13 preferably mutually limit a triangular or more angular area. Preferably each of these hoisting points 13 is located in the proximity of a suction pile 4, 5, such as at the cover thereof.

Preferably the centre of gravity 14 of the marine structure 1 is located at the position of a hoisting point 13 or between the hoisting points, as seen in top view. This position of the centre of gravity 14 is preferably obtained by ballast, preferably at a location at the side of the hoisting point 13 at the larger suction pile 4 facing at least one of the smaller suction piles 5, more preferably in the proximity

of or at the smaller suction piles 5, in top view. Advantageously a small suction pile is therefor equipped with concrete or other ballast material, e.g. present in the upper part of the suction pile 5.

5 It will be appreciated that the location in top view of the centre of gravity 14 is influenced by the position taken by the wind turbine 9, of which the centre of gravity 18 is present aside the longitudinal axis of the body 7. The position of the wind turbine 9 according to fig. 1-2 is therefor  
10 less convenient for the desired position of the centre of gravity.

As fig. 2 shows, the centre of gravity 14 keeps a large distance from the suction piles 4, 5. It will be appreciated to keep the level of the centre of gravity above the suction  
15 piles 4, 5 sufficient small, such that some tilting, e.g. during lowering onto the subsea bottom, of the marine structure 1 around the top side of the large suction pile 4 is allowable without the centre of gravity coming outside the area delimited by the hoisting points 13, in top view.

20 To be able to save ballast, one could maintain the marine structure 1 slightly tilted during transport over water and/or lowering onto the subsea bottom in the direction wherein, in top view, one tries to bring the centre of gravity 14 to a distance from the hoisting point 13. In the illustrated  
25 example one could tilt the marine structure in the direction of arrow A for this purpose. Preferably said tilting is such small that during the last phase while installing, wherein the lower side of the foundation part 2 starts to contact the subsea bottom, the marine structure automatically erects with  
30 ongoing lowering. This can e.g. be achieved by taking care that in the tilted position of the marine structure the centre of gravity 14 is positioned above the lowest point and the highest point at the lower side of the foundation part 2, which lowest and highest point are at least substantially at  
35 equal level if the marine structure stands upright.

The embodiment according to fig. 3-4 differs from that of fig. 1-2 in that the wind turbine 9 is replaced by an oil/gas platform 20. This platform 20 is mounted in an asymmetric

position to the upper structure part 3 such that the centre of gravity 15 of this platform is located, in top view, at the side of a hoisting point 13 facing at least one of the other hoisting points 13, more preferably at a location between the  
5 a three or multi angle forming hoisting points 13, which contributes to obtaining a desired position of the centre of gravity 14.

For transport over water at least one, more preferably at least two, most preferably at least three hoisting points 13,  
10 which in top view form preferably a three or multi angle, are mounted to a hoisting device, which is preferably located at the vessel, wherein preferably the hoisting device is designed such that at least one, preferably at least two hoisting  
15 points 13 can be lifted or lowered, independent from at least one other hoisting point 13. Fig. 4 shows in phantom the outline of the vessel 16. Hoisting members, such as hoisting cables, are connected to the three hoisting points 13 of the marine structure 1 and to hoisting equipment 17 of the hoisting  
20 device, such as winches or pulley blocks, which are present at the vessel 16 and project sideways therefrom. In the illustrated position the marine structure is transported over water. In top view the suction piles 4, 5 and the upper structure part 3 are present aside of the vessel 16, while the element 12, extending between the small suction piles 5,  
25 extends below the vessel 16. A part of the wind turbine 9 is present at a large distance above the vessel 16. Compared to the illustration of fig. 1-2, the wind turbine is swiveled around the longitudinal axis of the body 7, such that the centre of gravity 14 is brought more remote from the hoisting  
30 point 13 at the larger suction pile 4, which is more convenient for the stability of the marine structure, suspending from the pulley blocks 17. In stead of mounting of the marine structure 1 at a corner of the vessel 16, as shown in fig. 4, it is also possible to mount a, e.g. substantial wider, marine  
35 structure 1 at two corners of the vessel 16.

For transport over water the marine structure 1 can be kept immovable relative to the vessel 16 in a convenient manner as shown in fig. 4, such as by being stowed at it (not

shown) or by being pulled against the bottom side of stops (not shown).

Thus the marine structure 1, possibly after removal of the equipment to keep the marine structure immovable at the vessel 16 during transport, suspending with its hoisting points 13 from the pulley blocks 17, can be immediately lowered onto the subsea bottom 6 from the position shown in fig. 4, such as is shown in fig. 7. While lowering, the marine structure 1 is not obstructed by the vessel 16 and the marine structure moves exclusively in vertical direction relative to said vessel 16.

During lowering onto the subsea bottom 6 the vessel 16 is preferably fixed in position. This is possible by means of directly anchoring the vessel 16 to the subsea bottom 6, or by anchoring the towing vessels (not shown) connected to the vessel 16 to the subsea bottom. As a rule the anchoring lines will be controllably shortened and/or lengthened, and the anchoring points at the subsea bottom 6 determine a three of multi angle within which the vessel is present, in top view.

The vessel 16 will as a rule substantially be designed to provide buoyancy during transport and installation, and contains preferably a plurality of ballast tanks next and behind each other, such that it can be trimmed well. The vessel 16 can be propelled by at least one towing vessel and therefor does not have to be equipped with an own propulsion and/or housing for personell. The vessel 16 preferably has an at least substantially flat bottom and top side and/or in top view an at least substantially straight bow and/or stern and/or boards, which is convenient to transport the marine structure 1.

The embodiment according to fig. 8 differs from that of fig. 7 in that the element 12 between the smaller suction piles is removed. That is why the marine structure 1 can be suspended from the vessel 16 at a higher level, e.g. such that the bottom side of the foundation part 2 is at least at substantially the same level as the bottom side of the vessel, e.g. is present above said bottom side, as shown in fig. 8. Thus, compared to the embodiment of fig. 7, the draught of the

combination marine structure 1 and vessel 16 is made smaller, such that the invention also becomes applicable for shallow water depths.

5 After the marine structure has been lowered onto the subsea bottom, an under pressure is generated in the suction piles 4, 5 such that they are sucked into the subsea bottom. Then the installation is completed.

10 It will be appreciated that with the vessel 16 simultaneously more than one marine structure 1 can be transported over water in their installation and/or working position. E.g. a second, possibly at least substantially identical, marine structure 1 can be present at the diagonal opposite corner 19 of the vessel 16 (viz. fig. 9-10).

15 A possible variant of the invention contains more than three suction piles 4, 5 e.g. one or two additional smaller suction piles 5, present at the other side of the larger suction pile 4, such that in top view the foundation part 2 is at least substantially symmetrical relative to a mirror surface extending through the larger suction pile 4, and the  
20 larger suction pile 4 is present between said four smaller suction piles 5. As with the above described embodiments, the hoisting points 13 are preferably present at the larger suction pile 4 and the two smaller suction piles 5 at one side of the larger suction pile 4. With additional ballast or other  
25 provisions then preferably care is taken such that the centre of gravity 14 is located in the desired position in top view, i.e. preferably between the hoisting points 13. The marine structure can also be designed such that at least one suction pile 4, 5 is located straight below the vessel 16 during  
30 transport and/or lowering onto the subsea bottom. It is feasible that prior to lowering onto the subsea bottom the marine structure 1 is not or only hardly suspending from the vessel 16, e.g. in that the marine structure has buoyancy of its own which then prior to or during lowering onto the subsea  
35 bottom is removed in the desired rate such that the marine structure is installed while preferably suspended from the vessel 16. Another possibility is to remove at least one of the suction piles 4, 5 or replace it by a foot bearing onto

the subsea bottom, with possibly parts there below penetrating the subsea bottom by the action of weight, such as a so called "skirt". E.g. an embodiment based on fig. 1-4 is feasible, wherein all small suction piles 5 and the elements 11 have  
5 been removed, while the elements 12 are present at a higher level above the suction pile 4 and to a distance from the suction pile 4 have a hoisting point 13, such that in top view the centre of gravity 14 is located between the hoisting points 13. The body 7 can be substantially shorter, e.g. such  
10 that the marine structure is completely under water after installation.

Attention is also directed to an invention separate from or to be combined with the above or following, concerning a suction pile of which at least a part of the side wall is  
15 profiled, particularly wherein said profile extends at least substantially parallel to the direction from the lid to the open bottom side. Such a profile can be obtained by making use of a sheet pile profile known as such.

The suction pile according to the invention is preferably  
20 applied within a pattern of a plurality of at least two, more preferably at least three in top view mutually spaced suction piles with a foundation part that preferably determines an open structure (so called "space frame"), wherein said suction piles can be connected mutually and/or with at least one  
25 upward extending, elongated body, such as a pile or leg, of the possibly above the water level extending and on the foundation part resting upper structure part of the marine structure, possibly through the intermediary of a brace, stay or tube (so called "tubular"). In that case the suction piles  
30 provide the corners of a three of multi angle, in top view. The suction piles can have the same or different dimensions, and possibly be all embodied according to the invention.

Fig. 11 shows in top view of a non-limiting, presently most preferred embodiment the surrounding side wall 21 made of  
35 sheet pile profile of a suction pile. As known as such, the sheet pile profile is made from profiled sheet with a female and mating male locking profile, respectively, along its longitudinal edges.

Attention is also directed to an invention separate from or to be combined with the above or following, concerning a suction pile of which at least one of the walls is cured, initially shape free, rock like material, such as concrete, particularly wherein said material at least partly bears the loads of said wall which appear at one or several times during the life span. Therefor the material contains preferably convenient reinforcement of e.g. steel wire, such that not only compression loads, but also pulling loads can be beared. Preferably said wall is at least substantially completely made from such material.

It is convenient if in said material at least one element is at least partly embedded, which element is part of a structure mounted to the suction pile, such as the leg of a marine structure for which the suction pile at least partly provides the foundation, or a member to which such a leg can be fixed to fix said leg to said suction pile.

To ensure or increase the load transmitting capacity of the connection of the inventive wall of concrete o.a. to a further connecting wall of the suction pile and/or another element, it is preferred that projections of that further wall or element are embedded into the inventive wall.

According to a preferred embodiment the wall at the upper longitudinal end, also indicated as cover or "top plate" is made of such material.

The suction pile according to the invention is preferably applied within a pattern of a plurality of at least two, more preferably at least three in top view mutually spaced suction piles with a foundation part that preferably determines an open structure (so called "space frame"), wherein said suction piles can be connected mutually and/or with at least one upward extending, elongated body, such as a pile or leg, of the possibly above the water level extending and on the foundation part resting upper structure part of the marine structure, possibly through the intermediary of a brace, stay or tube (so called "tubular"). In that case the suction piles provide the corners of a three of multi angle, in top view. The suction piles can have the same or different dimensions,

and possibly be all embodied according to the invention.

Referring to enclosed fig. 12-14 a non-limiting, presently most preferred embodiment is illustrated. Fig. 12-14 show a side view, sectional side view and a partly cut away top view of the suction pile, respectively.

The illustrated suction pile has a circumferential side wall 31, has an open bottom 32 and has a cover 33 at the top, to which a leg 34 of a not further illustrated marine structure of a design known as such is mounted. The cover 33 is made of reinforced concrete. The pattern of the reinforcement 35 is shown in fig. 14.

The side wall is provided with a plurality of mutually spaced projections 36 in the form of pins or studs, which projections 36 are provided circumferentially over the thickness of the cover 33 and are directed radially inside from the inner side of the side wall. Also covering the thickness of the cover 33 there are circumferentially at the leg 34 corresponding projections 36 directed radially outside from the outside of the leg 34. The projections 36 are embedded in the concrete of the cover 33, such that a reliable mutual anchoring is present between the cover 33 and the side wall 31 and the leg 34, respectively.

To increase the mounting strength the leg 34 extends through a collar 38 mounted to the cover 33 and provided with mounting means, such as pretensioned tension bolts 37 to which the leg is fixedly welded.

The pattern of the reinforcement 35 is such that the concentrated load from the leg 34 is therewith equally distributed over the cover 33 and thus is gently transmitted to the side wall 31.

According to an alternative embodiment the leg 34 is not embedded into the material of the cover 33. In stead the pretensioned tension bolts 37 are replaced by in the material of the cover 33 moulded in pretension anchors extending over at least substantially the complete height of the cover 33, the upper ends of which extend above the cover 33. The kraag 38 is replaced by a flange plate resting with its lower face at the upper side of the cover 33 and fixated to the upper

ends of the pretension anchors. Afterwards a part of the marine structure, such as a leg 34, can be mounted to the flange plate above the cover 33, such as by welding. Within the pretension anchors a tension loads is present which is preferably such high that also with the highest expected compression load from the flange plate, tension stress acts in the pretension anchors while in the material of the cover 33 near the tension anchors compression stress always acts. The pretensioning also holds the lower face of the flange plate positively against the cover 33, such that flange plate and cover 33 can not easily slide mutually.

Attention is also directed to an invention separate from or to be combined with the above or following, concerning supporting a conductor or caisson or other tube projecting above the water level, particularly to transport crude oil or gas from a subterranean well to above the water level. In the following each time reference is made to a "tube" where it should be appreciated that an object such as a "conductor" or "caisson" is meant. It is expected that the most important field of application is a caisson which is designed to enclose the casings of at least two and preferably not more than five, most preferably not more than three wells.

This support can serve as temporarily support, e.g. while waiting for the provision of a production deck with its own foundation or a permanent support when the production deck is at least substantially supported by the relevant tube itself.

The object of the invention is simplifying.

According to the present invention such a tube is supported with at least two separate supporting braces, extending downwards inclined from the tube in different directions, and each founded with at least one suction pile present in the subsea bottom. The supporting braces are preferably at least substantially tension and compression proof. Preferably the straight connection lines of the suction piles cover with the tube an angle of more than  $45^\circ$  and less than  $180^\circ$ , preferably about  $90^\circ$ , in top view.

During installing of the suction pile the tube does not have to be used as pile guide. Prior to installation, the

suction pile can already be prepared for connection to the supporting brace, or even be mounted thereto. This is one of the reasons that the work can be carried out not only cheaper but also safer.

5       The supporting structure is preferably designed to bear at least substantially merely sideways directed loads from the tube. The tube bears at least substantially its own weight and that of a possible equipment mounted thereto or resting thereon, such as a beacon or a production platform or a so called christmas tree. Therefor the tube preferably extends  
10       deep enough into the subsea bottom to be at least substantially directly founded in the subsea bottom for at least vertical loads.

      If reference is made to "horizontal" and "vertical", this  
15       means the direction at least substantially parallel to the subsea bottom and at least substantially perpendicular to it, respectively. A supporting brace is preferably connected to the suction pile by a pile connection element allowing pivoting of the supporting brace relative to the suction pile in  
20       the horizontal and/or vertical plane. A supporting brace is preferably connected to the tube by a tube connection element that allows pivoting of the supporting brace relative to the tube in at least the vertical plane. Pile and/or tube connection element preferably have an at least substantially horizontal directed pivot pin. By means of this connection type  
25       positioning of the suction piles is less critical.

      Connection of the supporting brace to the tube can e.g. with a clamping connection means, such as a sleeve engaging around the pipe to make a clamping connection. Preferably the  
30       sleeve is part of the supporting brace. Preferably the sleeve is pivotably connected to the supporting brace such that while connecting the supporting brace to the suction pile, pivoting of the sleeve in the vertical plane relative to the bridging body is allowed. A convenient clamping connection means (e.g.  
35       so called "donkey dick pivot clamp") has two mutually pivoting sleeves, of which the one is clamped around the supporting brace and the other around the tube. This way of connection requires minimum divers assistance.

The supporting brace can have a monolithic or a spaced structure, such as a space frame.

Fig. 15 shows schematically in perspective a complete view and fig. 16 and 17 show detail views of a non-limiting, presently preferred embodiment of a from the subsea bottom upward above the water surface extending straight caisson with at its upper end a so called christmas tree (not shown), stabilised by two at a large distance below the water level to the caisson connected straight supporting rods which with their opposite end are connected to the top side of a respective suction pile which is sucked into the soil. The two suction piles make a mutual angle of approximately 90°. Outwardly from the caisson a riser can extend between the production deck and the subsea bottom. The top side of each suction pile was already above the water provided with the required equipment for coupling to the relevant supporting rod.

The installation procedure can be as follows: Prior to or after drilling of the wells the caisson is installed with the aid of the drilling rig. The suction piles are sucked into the soil. The supporting piles can be mounted to the suction piles prior to or after sucking in. Subsequently the supporting piles are mounted to the caisson. The drilling rig is removed, possibly after it is used to locate the production deck onto the caisson.

In fig. 15 additional supporting rods are illustrated in phantom, such that with an alternative embodiment two supporting rods extend under different angles from each suction pile to the caisson to be mounted to the caisson above and below the water level, respectively. A sleeve can be clamped around the caisson. Two additional sleeves can be mounted to the outer side of this sleeve in fixed angle positions. Each of these additional sleeves is clamped around the longitudinal end of a relevant supporting rod.

The invention also covers embodiments which are obtained by applying one or more separate features of the above described and/or in the drawing shown embodiment, possibly in combination with other features, such as one or more separate

features of one or more of the other above described and/or in the drawing shown embodiments.

## CLAIMS

1. Marine structure with a foundation part and an upper structure part extending therefrom upward, wherein said  
5 foundation part has at least one suction pile designed to at least partly penetrate the subsea bottom during installation; at least substantially in its operating position connected to a vessel to be below or aside it to be transported over water in an orientation such that the structure from its position  
10 mounted to the vessel can be immediately lowered onto the subsea bottom while suspending from a flexible pulling element of the vessel and in a stable balanced position.
2. Structure according to any of claim 1, held in a stable balanced position by convenient positioning of its centre of  
15 gravity such as by keeping it in an inclined attitude relative to its operating attitude and/or by making of of ballast.
3. Structure according to any of claim 1-2, with at least one larger suction pile (4) and a smaller suction pile (5).
4. Structure according to any of claim 1-3, each suction  
20 pile having a hoisting point (13), in top view mutually limiting a triangular area.
5. Structure according to any of claim 1-4, wherein the centre of gravity (14) is located between the hoisting points (13) in top view.
- 25 6. Structure according to any of claim 1-5, wherein the hoisting points (13) can be independently lifted relative to the vessel (16).
7. Structure according to any of claim 1-6, in top view are the suction piles (4, 5) and the upper structure part (3)  
30 aside the vessel (16).
8. Structure according to any of claim 1-7, mounted to a corner of the vessel (16).
9. Structure according to any of claim 1-8, wherein said upper structure part projects above water after installation  
35 and/or contains a device, such as a wind or water turbine or an oil or gas production platform with e.g. helicopter deck.
10. Structure according to any of claim 1-9, with a suction pile made of concrete or sheet pile.

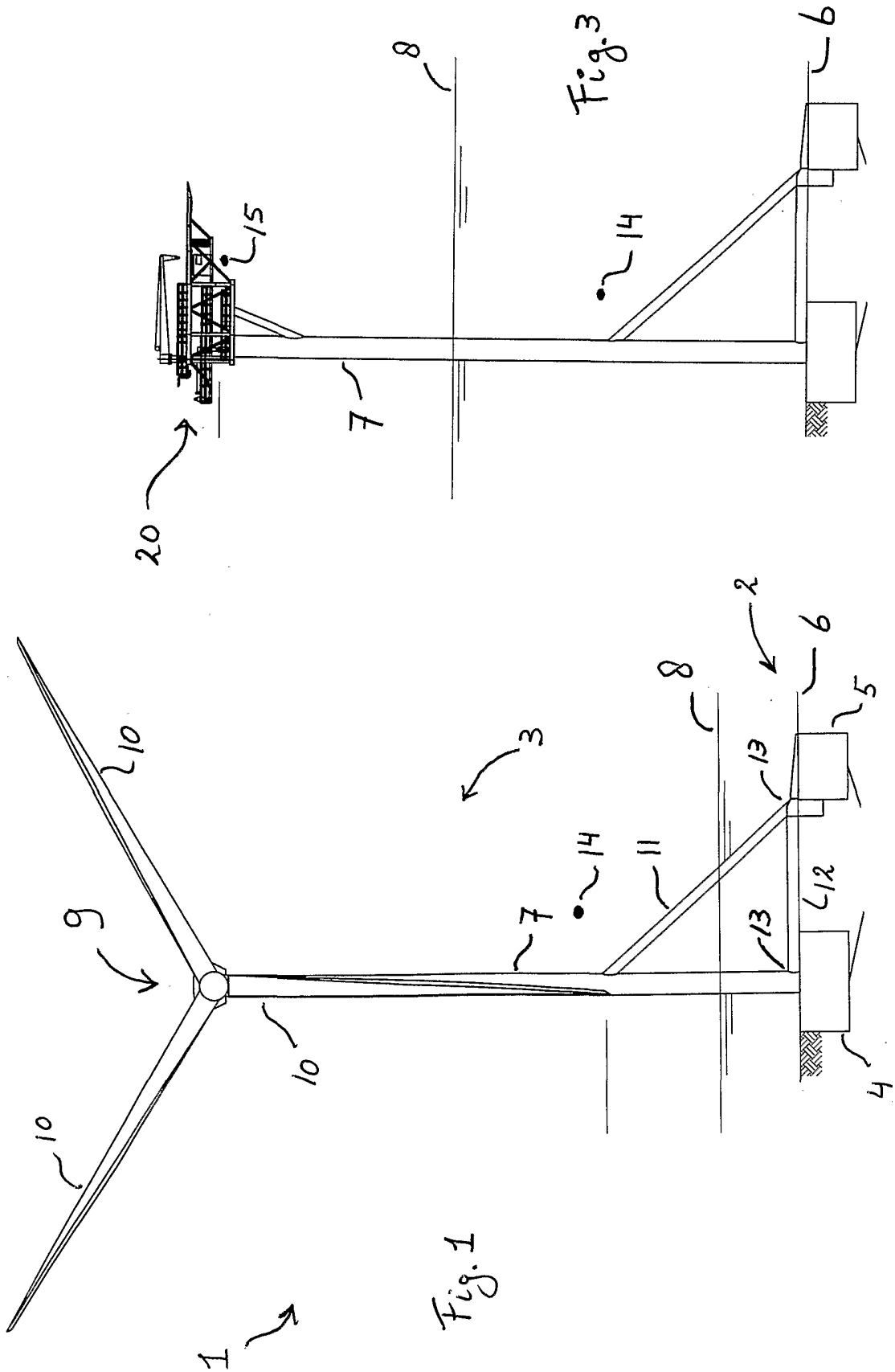

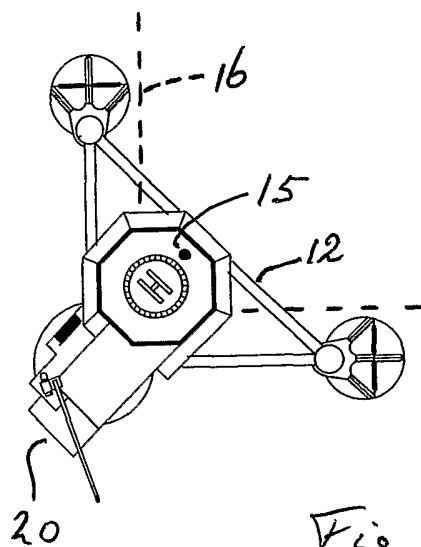

Fig. 4

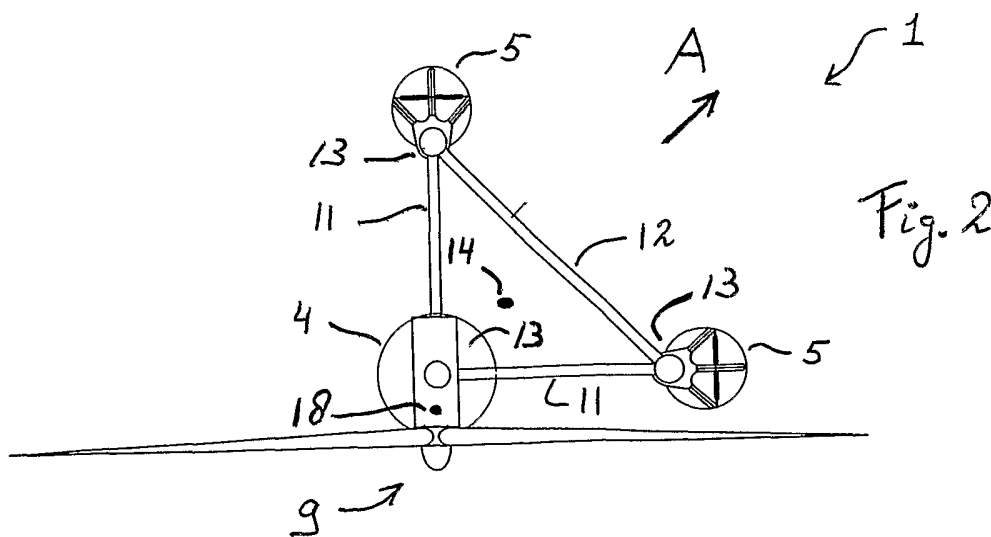
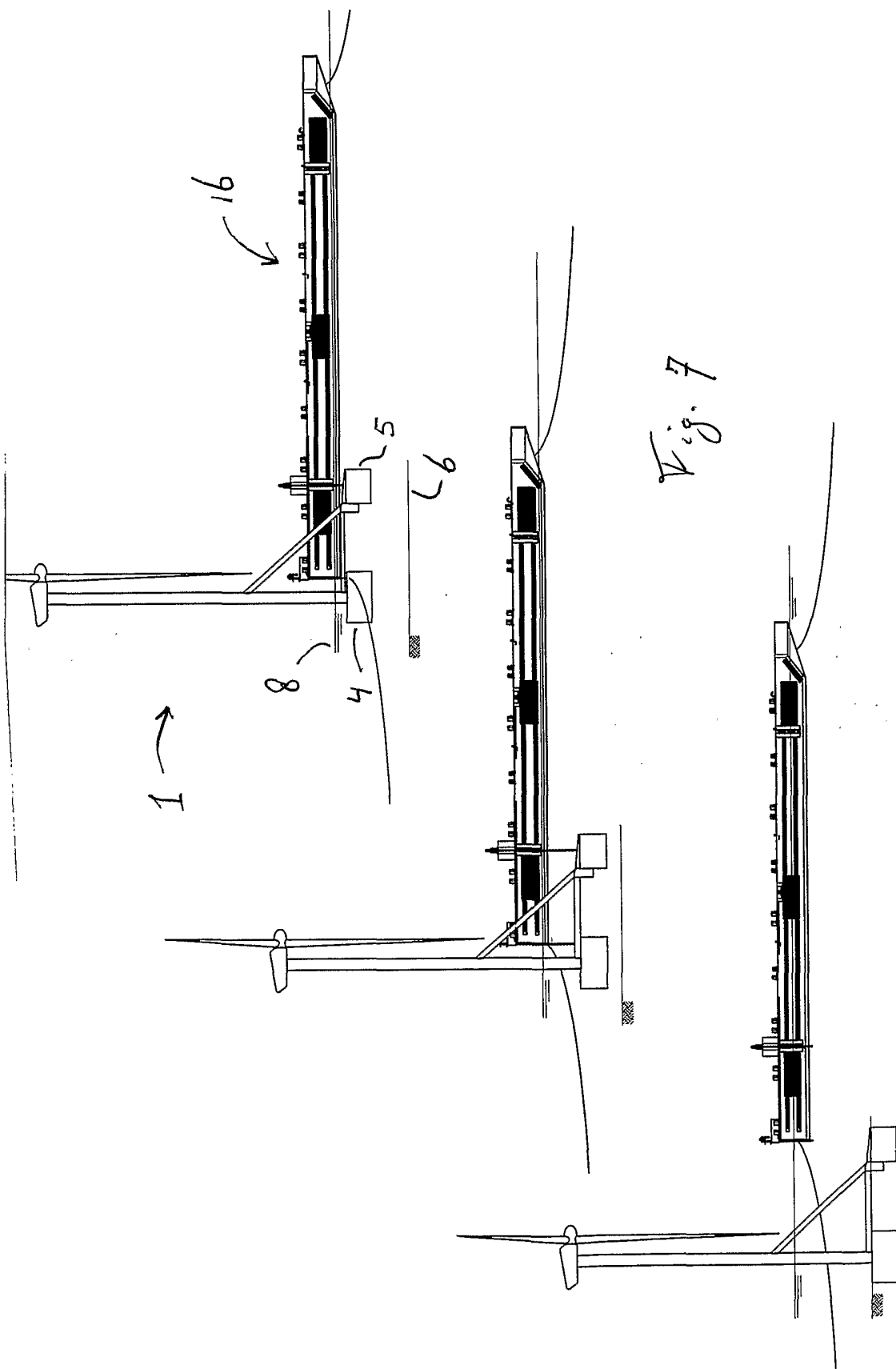

Fig. 2



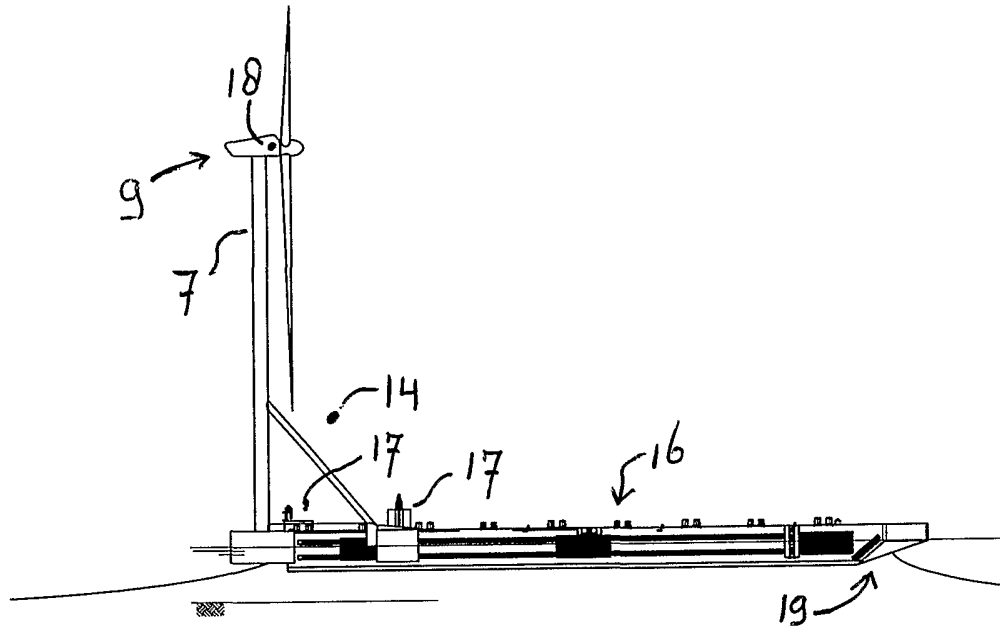

Fig. 8

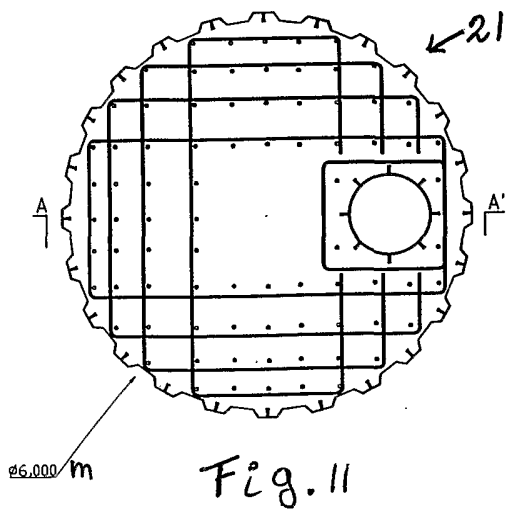

Fig. 11

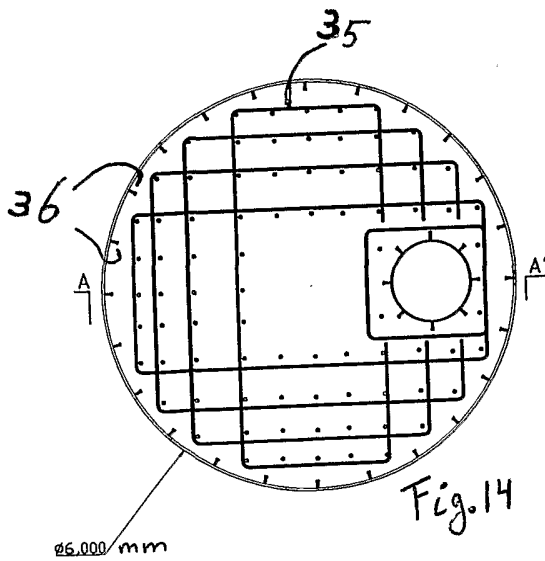

Fig. 14

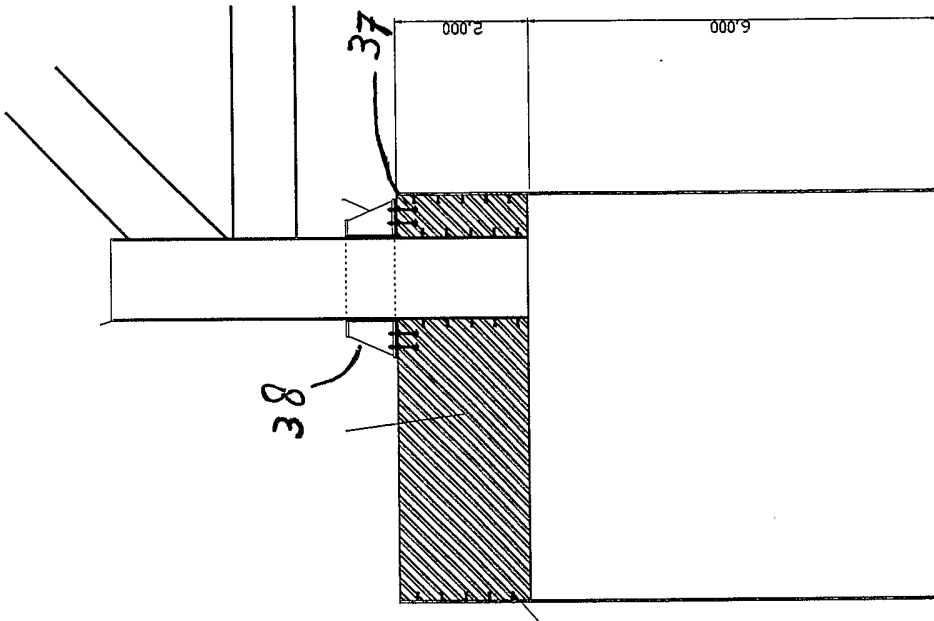

Fig. 13

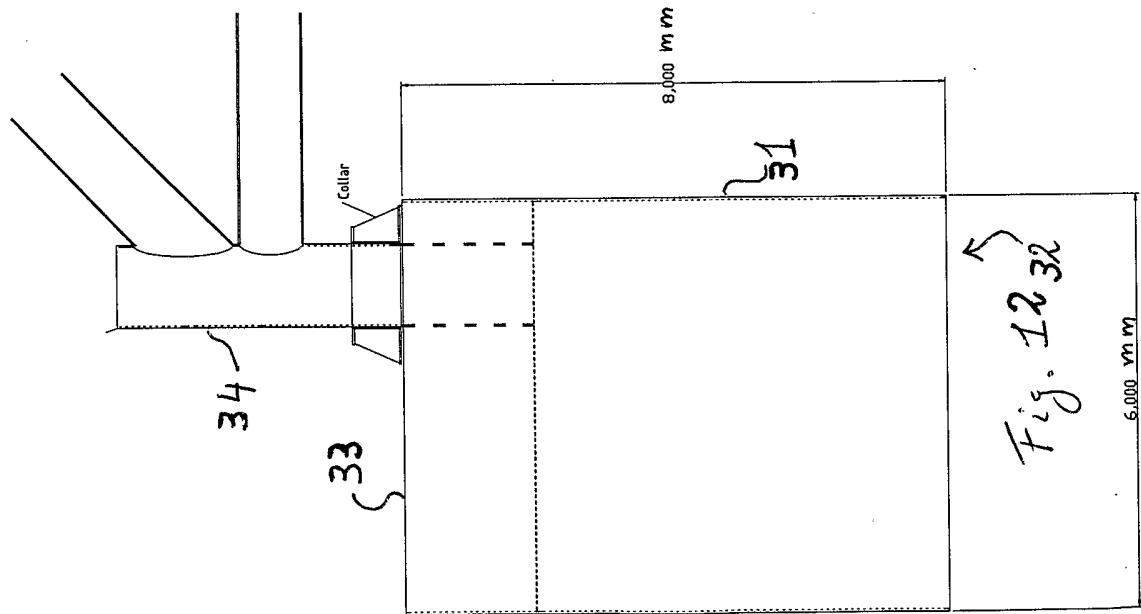

Fig. 12a

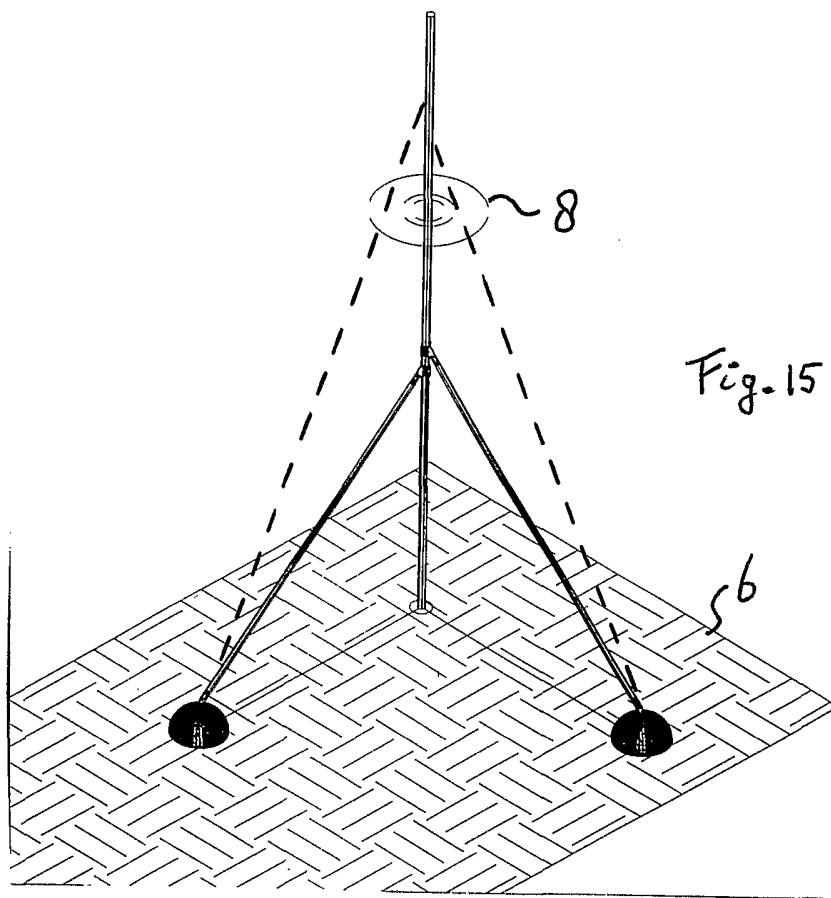

Fig. 15

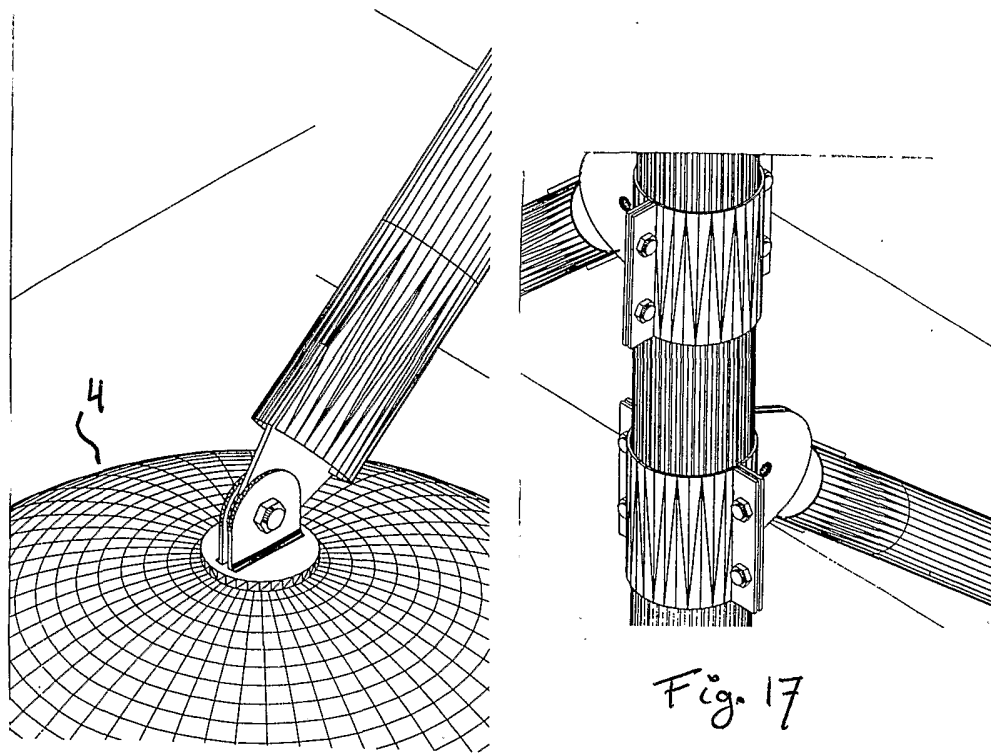

Fig. 16

Fig. 17

## INTERNATIONAL SEARCH REPORT

PCT/NL 02/00283

## A. CLASSIFICATION OF SUBJECT MATTER

IPC 7 E02D27/52 F03D11/04 B63B21/27 B63B21/50

According to International Patent Classification (IPC) or to both national classification and IPC

## B. FIELDS SEARCHED

Minimum documentation searched (classification system followed by classification symbols)

IPC 7 B63B E02D F03D

Documentation searched other than minimum documentation to the extent that such documents are included in the fields searched

Electronic data base consulted during the international search (name of data base and, where practical, search terms used)

EPO-Internal, WPI Data, PAJ

## C. DOCUMENTS CONSIDERED TO BE RELEVANT

Category *	Citation of document, with indication, where appropriate, of the relevant passages	Relevant to claim No.
X	DE 201 00 588 U (BRIESE REMMER) 22 March 2001 (2001-03-22) figures 1,2,4 page 7, line 16 -page 12, line 20	1,2,4-7, 9
X	NL 1 011 740 C (SUCTION PILE TECHNOLOGY B V) 5 October 1999 (1999-10-05) figures 1,2,8,9,15 page 7, line 15 -page 13, line 39	1,2,4-7, 9

 Further documents are listed in the continuation of box C. Patent family members are listed in annex.

## \* Special categories of cited documents :

\*A\* document defining the general state of the art which is not considered to be of particular relevance

\*E\* earlier document but published on or after the international filing date

\*L\* document which may throw doubts on priority claim(s) or which is cited to establish the publication date of another citation or other special reason (as specified)

\*O\* document referring to an oral disclosure, use, exhibition or other means

\*P\* document published prior to the international filing date but later than the priority date claimed

\*T\* later document published after the international filing date or priority date and not in conflict with the application but cited to understand the principle or theory underlying the invention

\*X\* document of particular relevance; the claimed invention cannot be considered novel or cannot be considered to involve an inventive step when the document is taken alone

\*Y\* document of particular relevance; the claimed invention cannot be considered to involve an inventive step when the document is combined with one or more other such documents, such combination being obvious to a person skilled in the art.

\*Z\* document member of the same patent family

Date of the actual completion of the international search

27 August 2002

Date of mailing of the international search report

05/09/2002

Name and mailing address of the ISA

European Patent Office, P.B. 5818 Patentlaan 2  
NL - 2280 HV Rijswijk  
Tel. (+31-70) 340-2040, Tx. 31 651 epo nl,  
Fax: (+31-70) 340-3016

Authorized officer

De Neef, K

# INTERNATIONAL SEARCH REPORT

Information on patent family members

PCT/NL 02/00283

Patent document cited in search report	Publication date	Patent family member(s)	Publication date
DE 20100588	U	DE 20100588 U1	22-03-2001
NL 1011740	C	NL 1011740 C1	05-10-1999
		AU 3174499 A	25-10-1999
		CA 2326431 A1	14-10-1999
		EP 1068403 A1	17-01-2001
		WO 9951821 A1	14-10-1999
		NO 20004845 A	27-09-2000