

Jan. 6, 1942.

P. S. VAN BLOEM

2,268,731

LIGHTING FIXTURE

Filed Dec. 14, 1940

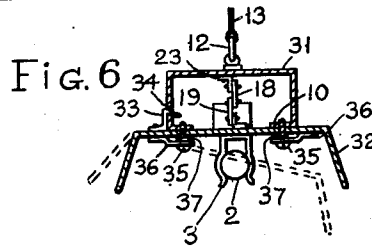
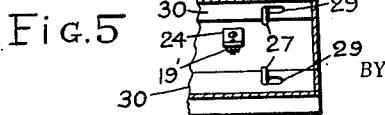
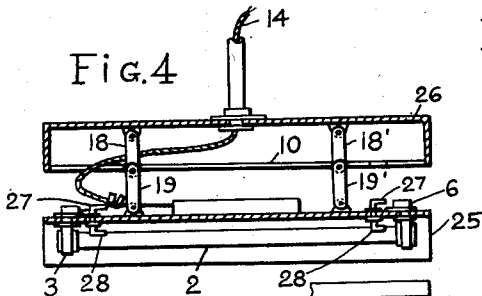
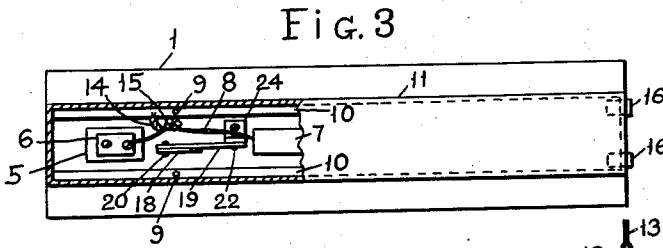
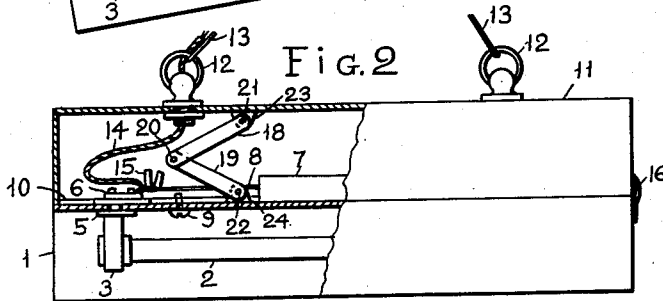
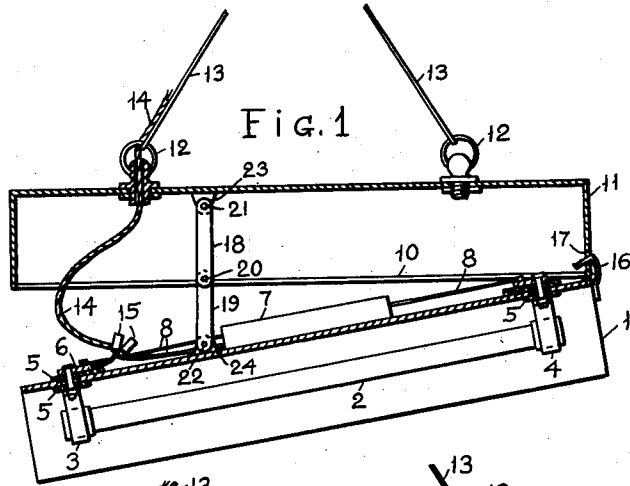

PAUL SCHUYLER VAN BLOEM

INVENTOR.

John P. Wilson

ATTORNEY

UNITED STATES PATENT OFFICE

2,268,731

LIGHTING FIXTURE

Paul Schwyler Van Bloem, Great Neck Estates,
N. Y., assignor to Gotham Pressed Steel Cor-
poration, New York, N. Y.

Application December 14, 1940, Serial No. 370,144

2 Claims. (Cl. 240—78)

My invention relates to lighting fixtures and has particular reference to fixtures for gas-filled lamps, especially of the fluorescent type.

A fluorescent lamp is usually placed in an elongated casing serving as a reflector, the electrical connections and a reactor or other similar devices being mounted on top of the casing. The reflector is attached to an upper casing forming a cover enclosing the connectors, the cover being supported on a conduit or suspended from a ceiling on chains or conduit pipe, electrical leads passing into the casing from the top. In order to make the electrical connections or to repair them, the reflector must be detached from the upper cover and held in the air while connections are being made. Such a procedure is very inconvenient and difficult, especially if the lamp is supported at an elevation so that a step ladder is required to reach it.

My invention has for its object to provide an arrangement whereby the reflector, when detached from the cover, is held suspended on hinged links at one end and on detachable hinges at the other end at such a distance that all the electrical connections can be easily made or repaired. The links are so made that they are automatically folded in a certain direction, so as not to interfere with the electrical contacts when the reflector is attached to the cover. The links can be entirely disconnected, if desired.

My invention is more fully described in the accompanying specification and drawing, in which:

Fig. 1 is a sectional elevational view of the lamp with the reflector and lamp detached from the cover and held on hinged links;

Fig. 2 is a similar view partly in section showing the reflector attached to the cover;

Fig. 3 is a top plan view partly in section;

Fig. 4 is an elevational view of a modified device;

Fig. 5 is a fractional sectional top plan view of the same; and

Fig. 6 is a sectional view of a modified device.

My lighting fixture consists of an elongated casing 1 representing a reflector for a fluorescent lamp or lamps 2. The latter is held in clamps or holders 3 and 4 supported on insulators 5 and having connectors or terminals on top of the casing. A reactor 7 or a similar device is also supported on the top, being connected with the lamp by leads 8.

The casing 1 is attached by screws 9 (Fig. 2) to flanges 10 of an upper casing or cover 11. The

latter has hooks or rings 12 suspended on wires or chains 13 from a ceiling or other stationary object (not shown). Leads 14 extend into the cover from the outside and are connected with the wires 8 as by solderless connectors 15.

For connecting the leads on top of the casing, the screws 9 are removed, freeing the casing 1. It is then allowed to drop, being held at one end on hinges consisting of hooks 16 engaging slots 17 in the cover. The front end of the casing 1 is suspended on two flat links 18 and 19 pivotally connected together at 20, the outer ends of the links being pivoted at 21 and 22 to brackets 23 and 24 attached to the upper and lower casings respectively. Due to this arrangement, the links can fold longitudinally of the casings in a definite direction, without interference with the wires or contact members.

The reflector casing 1 can be entirely removed by disconnecting the links 18 and 19 and sliding the hooks 16 from the slots 17, which can be done when the reflector 1 is turned downward at a large angle.

My arrangement has an advantage in that the end hinges keep the casings in alignment when the rear end of the lower casing is lowered and again raised to be fastened by the screws 9. The links can be made sufficiently long, so that with the front end in the lowered position, the electrical connections and wires are readily accessible for inspection, connections and repairs. The top cover can be made narrow, since it does not interfere with the lowering of the reflector with its electrical attachments.

A modified fixture is shown in Figs. 4 and 5. The reflector 25 is suspended from the cover 26 on two sets of links 18, 19 and 18', 19'. This arrangement may be preferred when both ends of the fixture must be accessible, but it has a disadvantage in that the reflector is not self-aligning with the cover, there being no aligning hinges.

Hooks 27 with handles 28 may be provided for clamping the reflector to the cover rotatively supported in the upper side of the reflector 25. The hooks pass through elongated holes 29 in the flanges 30 of the cover and are locked by turning the hooks at an angle to the holes 29.

Another modification is shown in Fig. 6. The cover 31 is attached by side hinges to the reflector 32, the hinges consisting of hooks 33 engaging slots 34. The reflector is fastened to the flanges 10 by screws 35, the latter being rotatively held in brackets 36 and being retained by enlarged portions 37. Links 18 and 19 support the

reflector in an inclined position when the screws are unscrewed from the flanges 10. The side hinges can be used under certain conditions, although under ordinary conditions end hinges are preferred, since with the side hinges the cover must be made relatively large, and it is difficult to obtain sufficiently large opening for making electrical connections when the front side of the reflector is lowered.

My method of suspension of the lower member of the combination can be used with a variety of different devices.

It is understood that my lighting fixture may be further modified without departing from the spirit of the invention, as set forth in the appended claims.

I claim as my invention:

1. A lighting fixture comprising an elongated lower casing, means to support an electric lamp in the casing, electrical connectors for the lamp on top of the casing, an elongated upper casing forming a cover for the lower casing, a pair of hinges at the rear walls of the casings, means to suspend the upper casing from a stationary object, the upper casing having flanges, means to detachably attach the flanges of the upper casing to the lower casing, a flat link pivotally connected at the end to the upper casing for rotation in the plane parallel to the longitudinal axis of the casing, and a second flat link pivotally connected to the lower casing for rotation in

the plane parallel to the longitudinal axis of the casing, the other ends of the links being pivotally connected together, the links being sufficiently long to support the lower casing with its end opposite the hinged end being downward inclined, the links being adapted to fold in the axial direction when the lower casing is raised and attached to the upper casing, the lower casing being thereby adapted to move only in the axial plane.

2. A lighting fixture comprising an elongated upper casing, means to suspend the casing from a stationary object, a lower elongated casing, means to support an electric lamp in the lower casing, electrical connectors for the lamp at the top of the lower casing, a pair of hooks at the rear wall of one of the casings hingedly engaging corresponding holes in the rear wall of the other casing, links connecting the lower casing with the upper casing at the front end, the links being of sufficient length to support the front portion of the lower casing in a downward inclined position, rendering accessible the electrical connectors at the front end of the lower casing, the links being adapted to fold in a predetermined position when the lower casing is raised and placed against the upper casing, and means to detachably attach the front end of the lower casing to the upper casing when the lower casing is raised.

PAUL SCHUYLER VAN BLOEM.