



(72) ALLPRESS, Stephen Alan, US

(72) HONCHARENKO, Walter, US

(72) LEE, David Y., US

(71) LUCENT TECHNOLOGIES INC., US

(51) Int.Cl.⁶ H04Q 7/30, H04Q 7/36, H04Q 7/32, H04Q 7/22, H04H 1/00

(30) 1998/04/24 (09/065,855) US

(54) **SYSTEME DE COMMUNICATION SANS FIL FIXE
MULTIMODE ET A DEBIT VARIABLE**

(54) **MULTI-MODE/MULTI-RATE FIXED WIRELESS
COMMUNICATION SYSTEM**

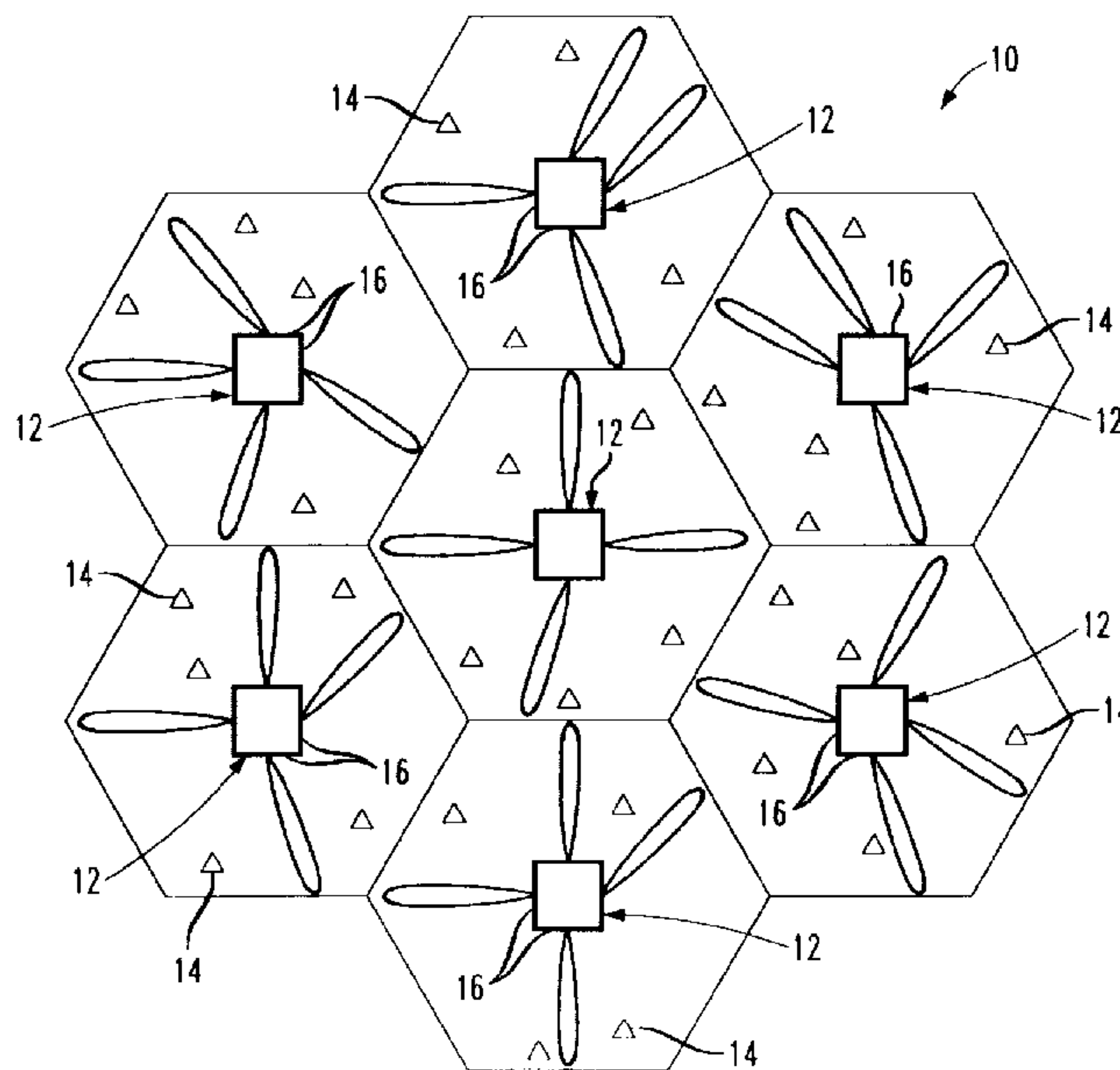

(57) A wireless communication system includes a base station having a defined geographic coverage area, the base station including a base receiver, a base transmitter, and a base antenna array. A subscriber station is located in the coverage area of the base station, the subscriber station including a subscriber receiver, a subscriber transmitter, and a subscriber antenna. The base antenna array is constructed and arranged to operate in a first mode wherein the array steers a narrow antenna beam in the direction of the subscriber station for transmitting first downlink signals to the subscriber station and for receiving first uplink signals from the subscriber station, and a second mode wherein the array defines a wide beam for transmitting second downlink signals simultaneously to a number of subscriber stations and for receiving second uplink signals from the subscriber stations. In one embodiment, the subscriber station transmitter is configured to modulate data on a selected number of carriers that are spaced spectrally from one another, to produce simultaneously a corresponding number of first uplink signals for reception at the base station. The number of carriers selected is a function of a desired data transmission rate.

MULTI-MODE/MULTI-RATE FIXED WIRELESS COMMUNICATION SYSTEM**Abstract:**

A wireless communication system includes a base station having a defined geographic coverage area, the base station including a base receiver, a base transmitter, and a base antenna array. A subscriber station is located in the coverage area of the base station, the subscriber station including a subscriber receiver, a subscriber transmitter, and a subscriber antenna. The base antenna array is constructed and arranged to operate in a first mode wherein the array steers a narrow antenna beam in the direction of the subscriber station for transmitting first downlink signals to the subscriber station and for receiving first uplink signals from the subscriber station, and a second mode wherein the array defines a wide beam for transmitting second downlink signals simultaneously to a number of subscriber stations and for receiving second uplink signals from the subscriber stations. In one embodiment, the subscriber station transmitter is configured to modulate data on a selected number of carriers that are spaced spectrally from one another, to produce simultaneously a corresponding number of first uplink signals for reception at the base station. The number of carriers selected is a function of a desired data transmission rate.

MODE/MULTI-RATE FIXED WIRELESS COMMUNICATION SYSTEM**Field of the Invention**

The present invention is directed to a spectrally efficient, point to multi-point communication system having one or more base stations and a number of system subscriber stations.

Discussion of the Known Art

A wireless local loop system known as "AirLoop" is available from the assignee of the present invention. The AirLoop system operates to connect, for example, telephone central switching sites to homes or businesses using fixed wireless equipment, instead of conventional copper wire pairs or "loops". Thus, subscribers within a coverage area of a system base station may enjoy the same features and services offered by existing wired local loop systems, for example, plain old telephone service (POTS) to ISDN.

U.S. Patent 5,448,753 (Sep. 5, 1995) discloses a wide area radio communication system in which central stations direct narrow antenna beams over sub-service areas, to communicate with peripheral stations in such areas during coordinated time intervals.

Summary Of The Invention

According to the invention, a base station having a defined geographic coverage area in a wireless communication system, includes a base receiver, a base transmitter, and a base antenna array coupled to the base receiver and the base transmitter. A base station processor is configured to exchange control and data signals with operating components of the base station. The antenna array is constructed and arranged to operate in a first mode wherein the array steers a narrow antenna beam in the direction of a subscriber station in the coverage area of the base station, for transmitting first downlink signals to the subscriber station and for receiving first uplink signals from the subscriber station, and a second mode wherein the array defines a wide beam for transmitting second downlink signals simultaneously to a number of subscriber stations in the coverage area and for receiving second uplink signals from the subscriber stations.

According to another aspect of the invention, a subscriber station for deployment in a wireless communication system, includes a subscriber receiver, a subscriber transmitter, and a subscriber antenna coupled to the subscriber receiver and the subscriber transmitter. A subscriber station processor is configured to exchange control and data signals with operating components of the subscriber station. The subscriber station transmitter is constructed and arranged to modulate data on a selected number of carriers which carriers are spaced spectrally from one another, to

2

produce simultaneously a corresponding number of first uplink signals for reception at a system base station having a coverage area in which the subscriber station is located. The number of carriers selected for transmission is a function of a rate at which a user desires to transmit data from the subscriber station to the base station.

5 For a better understanding of the invention, reference is made to the following description taken in conjunction with the accompanying drawing and the appended claims.

Brief Description Of The Drawing

In the drawing:

10 FIG. 1 is a plan view of a communication system according to the invention, showing base and subscriber stations over a wide geographic area;

FIG. 2 is a graph of a frequency spectrum allotment for a base station in the system of FIG. 1;

FIG. 3 is a graph of a frequency spectrum allotment for a subscriber station in the system of FIG. 1;

15 FIG. 4 is an elevation view of an antenna element array panel situated at a base station of the system;

FIG. 5 is a top view of four of the panels in FIG. 4 mounted on corresponding sides of a base station structure;

FIG. 6 is a schematic diagram of a base station transmitter;

20 FIG. 7 is a schematic diagram of a base station receiver;

FIG. 8 is a schematic diagram of a subscriber station transceiver (transmitter/receiver) unit; and

FIG. 9 is a pictorial representation of an entire subscriber station.

Detailed Description Of The Invention

25 A fixed wireless communication system 10 according to the invention provides high rate connectivity for either circuit or packet switched networks, by incorporating both antenna array and block radio techniques. The system 10 embodies two transmission modes. Specifically, a high rate, single carrier scheme shown in FIG. 2 is implemented for downlink transmissions from each

base station 12 to covered subscriber stations 14. For uplink transmissions from a subscriber to an assigned base station, a multi-carrier, variable bandwidth scheme is implemented per FIG. 3. Preferably, separate frequency bands are allocated for the uplink and the downlink transmissions. The system 10 also permits a significant degree of frequency reuse to be achieved for each of the
 5 base stations and their covered subscribers.

Each base station 14 is provided with a number of antenna array panels 16. See FIGS. 4 and 5. Each panel 16 is capable of producing either a broad, or a steerable, narrow beam pattern. The base station 14 also has a base transmitter 18 (FIG. 6) and a base receiver 20 (FIG. 7). Each subscriber station includes a patch array antenna, and a transceiver unit 22 shown in FIG. 8.

10 Base stations 14 of the system 10 are deployed on a semi-regular hexagonal grid, to provide coverage over relatively large geographic areas. Preferably, at least three antenna panels provide 360° coverage over each base station's geographic area. Each array panel thus affords a coverage of $(360/N)^\circ$, where N is the number of antenna array panels.

In the embodiment of FIGS. 1, 4 and 5, four array panels 16 are mounted on
 15 corresponding sides of a subscriber's building. Each base antenna array panel comprises a 12 x 4 array of radiating elements 24 which when suitably driven form an antenna pattern beam approximately 10° in azimuth and 30° in elevation. In the disclosed embodiment, phase centers of the radiating elements 24 are spaced at one-half the wavelength of the operating frequency of the system 10. For example, about 8-cm spacing for an operating frequency of 1900 MHz. A
 20 base station 12 is then able to move or electronically "steer" its antenna beam in the direction of a given subscriber station 14 either to transmit information/data to, or to receive information/data from, a user at the subscriber station 14.

Radio frequency (RF) components of a subscriber station may be incorporated within a subscriber "unit" 26 shown in FIG. 9. The unit 26 is mounted, for example, to the side of a subscriber's
 25 building, near the roofline of the building. The unit includes an integrated patch antenna array 28 having a pattern which in the illustrated embodiment is fixed in azimuth and in elevation. The subscriber unit 26 also contains the transceiver unit 22 including RF and digital electronic components used for information or data transmission and reception. A connection is made between the subscriber unit 26 and a personal computer (i.e., terminal equipment) 30 using, e.g.,
 30 a standard Ethernet 10BaseT connection 32.

Base Station to Subscriber Transmission Mode

Signal transmissions from a base station 12 to a covered subscriber station 14 in the present embodiment employ square constellation M-ary quadrature-amplitude modulation (QAM).

4

For example, a symbol rate of 800 kHz is used, and a minimum bit rate is defined at 1.6×10^6 bits/sec (bps) using quadrature phase shift keying (QPSK). Use of a 64-QAM constellation can allow data rates of up to 4.8 Mbps to be transmitted in a 1-MHz channel allotment, provided signal-to-interference (S/I) levels are high enough to ensure quality of service. An 800 kHz symbol rate allows base station downlink signals to remain within a 1-MHz channel bandwidth, with 25% excess bandwidth ($800 \text{ kHz} * 1.25 = 1 \text{ MHz}$). To improve the performance of a receiver of the subscriber transceiver unit 22 (upper portion of FIG. 8) in the presence of multipath downlink signals, a decision feedback equalizer (DFE) 34 is preferably included in a demodulator 36 of the transceiver unit 22. Forward error correction (FEC) coding may also be implemented to improve the performance of the downlink signal transmissions as is known generally in the art.

Subscriber to Base Station

Signal transmissions from a subscriber station 14 to an assigned base station 12 are preferably made using a variable rate, multi-carrier QAM scheme. A minimum data modulation constellation for the transmissions is, for example, 4-ary QAM which is the same as QPSK. The modulation constellation density may be set higher, up to, e.g., 64 QAM if S/I levels permit.

A subscriber station may use, for example, up to ten separate carriers (or "sub-carriers") contained within a typical 1-MHz subscriber frequency band allotment, as shown in FIG. 3, to transmit data via uplink signals to its base station 14. At QPSK rates, each of the carriers will thus carry data at a minimum rate of 160 kbps. Higher order modulation densities will increase the throughput (e.g., 64 QAM provides 6 bits/symbol to yield 480 kbps), if required. Thus, an individual user can aggregate multiple carriers in order to transmit symbol rates higher than 80 kHz.

Importantly, one or more of a subscriber station's available carriers can be used to define a random access channel. A user who is ready to transmit data to his/her base station may, by using the random access channel, request the base station to poll or schedule the user for the data transmission.

An advantage of a multicarrier scheme according to the invention is that it allows multiple subscribers to transmit uplink data signals, simultaneously to a common base station. When a user transmits data in a non-multicarrier (i.e., single frequency channel) system, the channel is occupied for the duration of the transmission. Therefore, another user must wait for the channel to become clear before transmitting his/her own data. In the system 10, if a user requires only a low-rate uplink to send short data requests to the base station (e.g., a mouse click), only one carrier of the

user's multicarrier allotment is occupied. Remaining carriers are left open thus allowing the carriers to be available for another subscriber's use.

Another advantage of the multicarrier system 10 is that the need for an equalizer for each base station receiver may be eliminated. That is, delay spreads for a fixed wireless system using narrow beam antenna patterns at both the base and the subscriber stations are typically only a few hundred nanoseconds. Thus, for data transmission at a maximum 80 kHz rate on any one uplink carrier signal, an equalizer is not necessary to compensate for data symbol errors induced by multipath propagation from a subscriber to the base station.

In a preferred embodiment, the multicarrier system 10 incorporates a software radio system using commercially available digital up-conversion filter banks, to permit a transmitter of each subscriber transceiver unit 22 (lower portion of FIG. 8) to originate multiple carrier signals according to the invention. The digital upconverters themselves are constructed and arranged to generate multiple independent data streams on carriers separated in frequency by the allotted carrier spacing (e.g., 100 kHz). Geographic coverage areas are assumed to be substantially circular in shape, with the base stations 12 arranged over a hexagonal grid to minimize overlaps in coverage, as shown in FIG. 1.

Base Station Antenna Array

Each base station antenna array panel 16 has, for example, 48 radiating elements 24 configured in a 12 x 4 pattern, as shown in FIG. 4. Each set of four vertical elements 24 is coupled to a different one of 12 base transmitters 18 (FIG. 6) and 12 base receivers 20 (FIG. 7). The base receivers and transmitters incorporate beamformers 40, 42 that are constructed and arranged to adjust the phase and amplitude of an RF signal according to a desired synthesis algorithm for transmission, or to an adaptive algorithm for reception. Phase and amplitude weights for each of the 12 vertical sets of antenna array panel elements 24, are preferably hard-wired so the weights are not changed through the azimuth (horizontal) pattern beam-forming process.

Calibration of Base Station Antenna Array

To synthesize a narrow beam pattern for a base antenna array panel 16, for transmitting downlink data signals to subscribers, the total RF phase lengths from a base transmitter 18 to each array panel element 24 must be known accurately. Phase accuracy of one degree or better at the operating RF wavelength will ensure that nulls in the array pattern are sufficiently deep (e.g., more than 20dB) to minimize interference. Only relative phase differences between the array panel elements 24 need be determined, however.

To calibrate relative phase paths between a base transmitter 18 and antenna elements 24 on a given panel 16, any one set of four vertical elements can be used as a calibration source. The array is preferably calibrated at time of assembly, and calibration error due to mechanical variations is negligible when compared to phase variations of cables, amplifiers, and other active and passive elements in the transmitter-antenna path.

A signal is injected periodically into one of the antenna elements (i.e., a reference element) and the relative phase between the reference element and each the other elements 24 is measured. The measured phase difference between any pair of elements is then compared to the known (i.e., spatial) phase difference between the elements, and the calibration process computes corresponding phase offsets to maintain the antenna elements in proper phase alignment. The phase offsets are then used in a weight computation for beam synthesis, are stored in the beamformer, and are adjusted periodically. The calibration period thus may be on the order of hours, without a significant loss in performance of the array between calibration periods.

Subscriber Unit

The subscriber unit 26 in FIG. 9 preferably includes a wireless modem 46. The modem 46 is coupled via a connecting cable 48 to the interface 32 for the user's terminal equipment 30. The terminal equipment can be, for example, a data-only personal computer as shown, or a telephony terminal. The antenna 28 and RF components are housed in a common unit enclosure that is mounted, e.g., to the side of a building or to a mast extending slightly above the highest point of the subscriber's building. The radiation pattern of the subscriber antenna 28 is, for example, about 18° in azimuth and about 18° in elevation.

System Air Interface

The air interface for the system 10 can be specified as follows:

1. For subscriber access - Low rate subscriber access channel, and broad/narrow beam base station antenna patterns.

As described above, a multiple carrier access scheme is implemented for uplink data transmission, using multiple narrowband frequency channels spaced on 100 KHz centers all within a 1-MHz subscriber allotment. See FIG. 3. One of these channels is preferably dedicated as a random access channel on which users wishing to transmit data can signal a request to authenticate, or a request to transmit data, to a base station.

When a base station antenna array is driven to form a narrow beam pattern, it is unlikely that the beam will be pointed or steered to a particular user at the exact moment he/she tries to

transmit data to the base station. To allow all users access to the random access channel at any time, the base station antenna beam must be sufficiently wide always to respond to a signal on the channel from any covered subscriber.

Thus, according to the invention, an antenna beam pattern covering an entire field of view of each base station array panel is synthesized at desired time intervals. For a 90° field of view for each array panel, the gain of the panel is reduced about 9 dB. Any loss of signal-to-noise performance due to this antenna gain reduction can be compensated for by setting the subscriber transmission rate to, e.g., one-tenth the normal rate, or about 10k symbols per second. The actual bit rate will depend on the modulation scheme and constellation density.

Users located near their base station and having a high signal-to-noise ratio, may nevertheless be able to maintain a high density QAM constellation when in a random access channel mode of operation. Users further away, or those having a poor signal-to-noise ratios, may have to switch to a QPSK modulation constellation to ensure reception when the base station antenna pattern is widened to service the random access channel. An access protocol suitable for use on the random access channel of the system 10, is preferably based on an "ALOHA" protocol well-known to those skilled in the art.

A downlink "beacon" signal from each base station should provide authentication, acknowledgment, and access information to subscriber stations. The signal preferably occupies a fixed length time slot, and should be transmitted periodically using the broad (e.g., $4 \times 90^\circ = 360^\circ$) base station antenna pattern to ensure that all subscribers will receive the beacon signal. The base station information transmission rate for the beacon signal is preferably reduced by the amount necessary to compensate for loss of antenna gain, relative to the gain when in a narrow-beam downlink data transmission mode.

2. For Subscriber Data Transmission and Reception -Packetized traffic/data channel modulation, and subscriber antenna pattern.

Message data or traffic from a subscriber station 14 is transmitted to a base station 12, preferably using an m-ary QAM modulation scheme on one or more uplink carrier signals. If the amount of data, or the subscriber's data rate requirement is low, then only one 100 KHz wide channel may suffice for the subscriber's needs. If a higher data rate is required, then multiple, 100 KHz spaced carriers are requested by the user. As mentioned, data can be transmitted at a symbol rate of 80 KHz on each uplink carrier, and the data rate can vary from 160 kbps to 480 kbps, depending on the modulation constellation density.

Example Of System Subscriber Call Set Up Procedure

A procedure to initiate a call or "session" by a user at a subscriber station, begins with the user initiating a request for service to its base station. The subscriber unit receives the beacon signal during an assigned time slot from the base station, and transmits on the uplink random access channel. If the subscriber's random access transmission is not corrupted by a collision with another transmission from another subscriber on the common channel, the base station will acknowledge the subscriber's request using the base station's broad beam messaging channel.

Once authentication data is exchanged between the subscriber and the base stations, the base station directs a narrow beam toward the subscriber station by adjusting complex weights in the base station's beamformer. For reception at the base station, array weights are computed via an adaptive algorithm, and the output of the adaptive algorithm is used to compute the downlink direction. That is, the base station processes RF signals received by the sets of spaced elements on its antenna array panels, and computes the direction from which a subscriber's signal originates. For downlink transmissions from the base station, the array weights are either precomputed and stored for subscribers who have used the system over a period of time, or the weights are computed based on the direction of arrival of the subscriber's signal per the mentioned adaptive algorithm. As additional users request service, the narrow antenna beam of the base station is steered to cover all transmitting subscribers, to allow them to transmit data to the base station using the described multi-carrier scheme.

In sum, the system 10 provides the following desirable features:

1. A steerable beam antenna at each base station and periodically operating with a wide-beam "beacon" patten.
2. A dual mode transmission scheme, viz., a fast single carrier downlink, and a parallel multicarrier uplink.
3. A packet radio scheme can be used for both of the up and the down links.
4. A desired user bandwidth on demand available in the uplink; simultaneous uplink transmissions from multiple users (locations).
5. Block radio detection can be implemented at the base stations.
6. QPSK modulation or a higher level QAM is selected according to the S/I conditions of users.

While the foregoing description represents a preferred embodiment of the invention, it will be obvious to those skilled in the art that various changes and modifications may be made, without departing from the true spirit and scope of the invention pointed out by the following claims.

Claims:

1. A base station having a defined geographic coverage area in a wireless communication system, comprising:

5 a base receiver, a base transmitter, and a base antenna array coupled to the base receiver and the base transmitter;

a base station processor configured to exchange control and data signals with operating components of the base station;

10 wherein said base antenna array is constructed and arranged to operate in a first mode wherein the array steers a narrow antenna beam in the direction of a subscriber station in the coverage area of the base station, for transmitting first downlink signals to the subscriber station and for receiving first uplink signals from the subscriber station, and a second mode wherein the array defines a wide beam for transmitting second downlink signals simultaneously to a number of subscriber stations in said coverage area and for receiving second uplink signals from said number of subscriber stations.

15 2. A base station according to claim 1, wherein said base transmitter is configured to transmit downlink signals on a single carrier within a first frequency spectrum allotment, and said base receiver is configured to receive uplink signals on more than one carrier from a subscriber station when the subscriber station transmits up to a maximum number of carriers within a second frequency spectrum allotment.

20 3. A subscriber station for deployment in a wireless communication system, comprising:

a subscriber receiver, a subscriber transmitter, and a subscriber antenna coupled to the subscriber receiver and the subscriber transmitter; and

a subscriber station processor configured to exchange control and data signals with operating components of the subscriber station;

25 wherein said subscriber station transmitter is constructed and arranged to modulate data on a selected number of carriers which carriers are spaced spectrally from one another, to produce simultaneously a corresponding number of first uplink signals for reception at a system base station having a coverage area in which the subscriber station is located; and

30 wherein the number of carriers selected for transmission is a function of a rate at which a user desires to transmit data from the subscriber station to the base station.

4. A subscriber station according to claim 3, wherein the subscriber receiver, subscriber transmitter and subscriber antenna are in the form of a wireless modem unit for mounting on a building.

5. A subscriber station according to claim 4, including subscriber terminal equipment, and an interface for coupling the terminal equipment to said wireless modem unit.

6. A wireless communication system, comprising:

a base station having a defined geographic coverage area, the base station including a base receiver, a base transmitter, and a base antenna array coupled to the base receiver and the base transmitter;

10 a base station processor configured to exchange control and data signals with operating components of the base station;

a subscriber station located in the coverage area of the base station, the subscriber station including a subscriber receiver, a subscriber transmitter, and a subscriber antenna coupled to the subscriber receiver and the subscriber transmitter; and

15 a subscriber station processor configured to exchange control and data signals with operating components of the subscriber station;

wherein said base antenna array is constructed and arranged to operate in a first mode wherein the array steers a narrow antenna beam in the direction of the subscriber station for transmitting first downlink signals to the subscriber station and for receiving first uplink signals from the subscriber station, and a second mode wherein the array defines a wide beam for transmitting second downlink signals simultaneously to a number of subscriber stations in said coverage area and for receiving second uplink signals from said number of subscriber stations.

7. A communication system according to claim 6, wherein said base transmitter is configured to transmit downlink signals on a single carrier within a first frequency spectrum allotment, and said base receiver is configured to receive uplink signals on more than one carrier from a subscriber station when the subscriber station transmits up to a maximum number of carriers within a second frequency spectrum allotment.

8. A communication system according to claim 6, wherein the subscriber receiver, subscriber transmitter and subscriber antenna are in the form of a wireless modem unit for mounting on a building at the subscriber station.

30

12

9. A communication system according to claim 8, including subscriber terminal equipment at the subscriber station, and an interface for coupling the terminal equipment to said wireless modem unit.

10. A wireless communication system, comprising:

5 a base station having a defined geographic coverage area, the base station including a base receiver, a base transmitter, and a base antenna array coupled to the base receiver and the base transmitter;

a base station processor configured to exchange control and data signals with operating components of the base station;

10 a subscriber station located in the coverage area of the base station, the subscriber station including a subscriber receiver, a subscriber transmitter, and a subscriber antenna coupled to the subscriber receiver and the subscriber transmitter; and

a subscriber station processor configured to exchange control and data signals with operating components of the subscriber station;

15 wherein said subscriber station transmitter is constructed and arranged to modulate data on a selected number of carriers which carriers are spaced spectrally from one another, to produce simultaneously a corresponding number of first uplink signals for reception at the base station; and

wherein the number of carriers selected for transmission is a function of a rate at which a user desires to transmit data from the subscriber station to the base station.

20 11. A communication system according to claim 10, wherein said base transmitter is configured to transmit downlink signals on a single carrier within a first frequency spectrum allotment, and said base receiver is configured to receive uplink signals on more than one carrier from a subscriber station when the subscriber station transmits up to a maximum number of carriers within a second frequency spectrum allotment.

25 12. A communication system according to claim 10, wherein the subscriber receiver, subscriber transmitter and subscriber antenna are in the form of a wireless modem unit for mounting on a building at the subscriber station.

30 13. A communication system according to claim 12, including subscriber terminal equipment at the subscriber station, and an interface for coupling the terminal equipment to said wireless modem unit.

FIG. 1

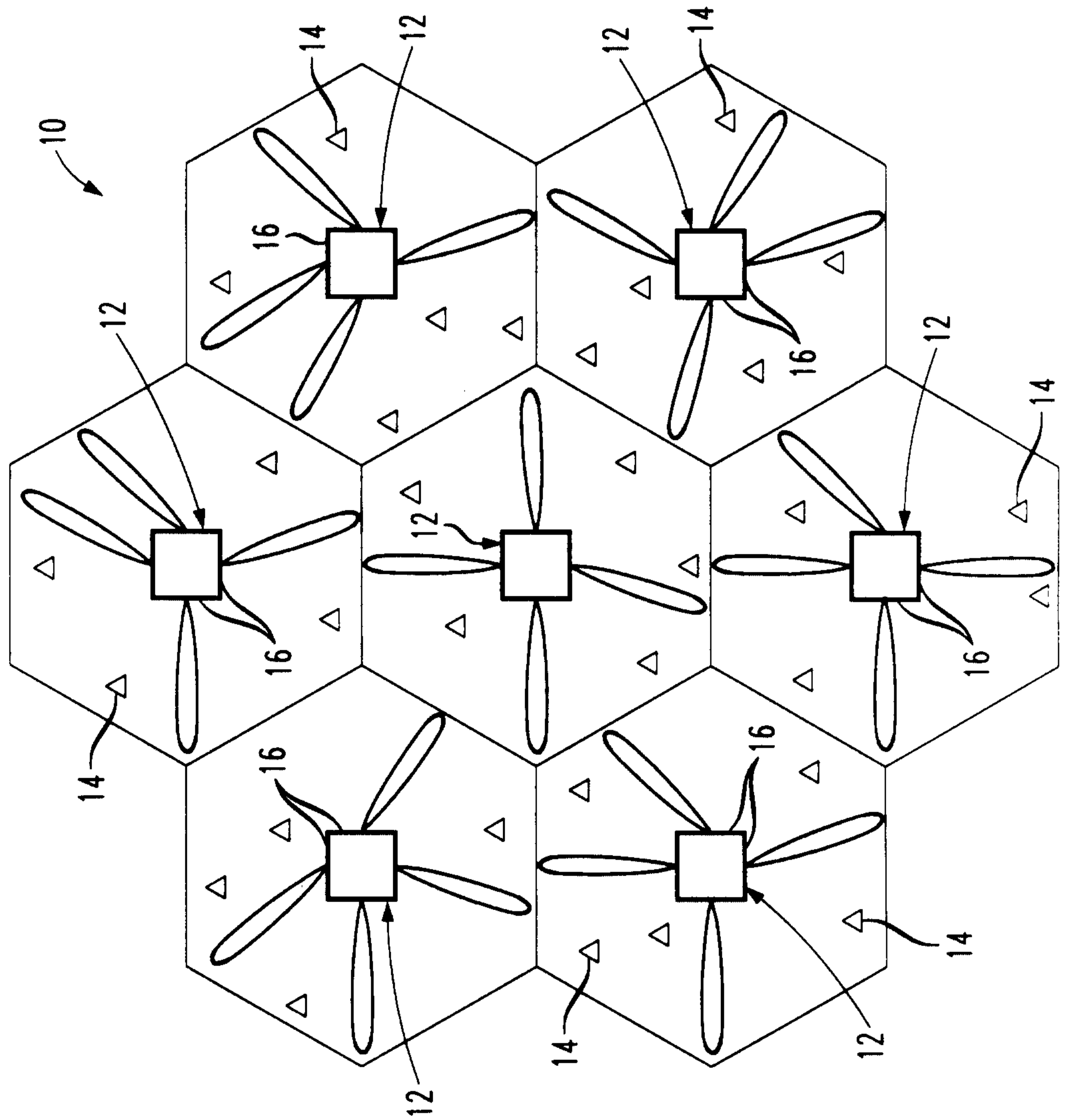
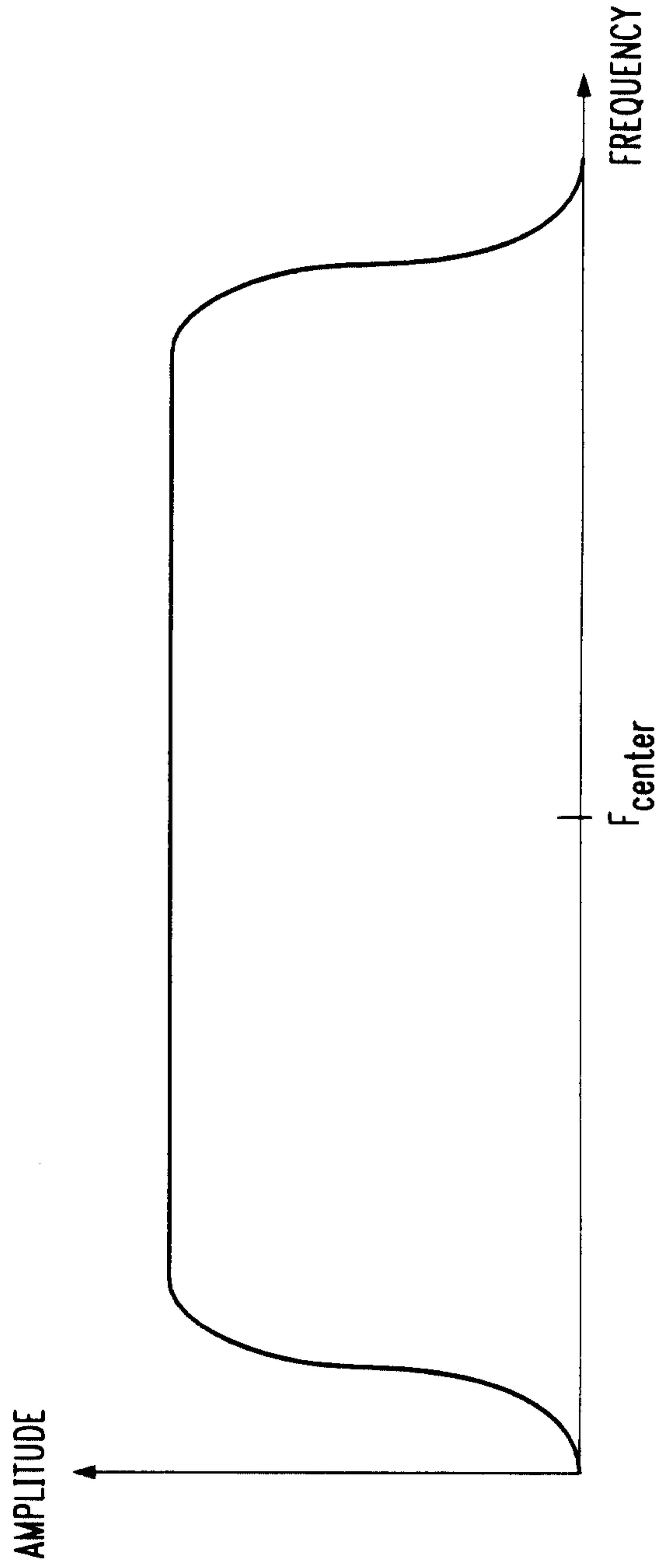

FIG. 2

DOWNLINK TRANSMISSION SPECTRUM



3/8

FIG. 3

UPLINK TRANSMISSION SPECTRUM

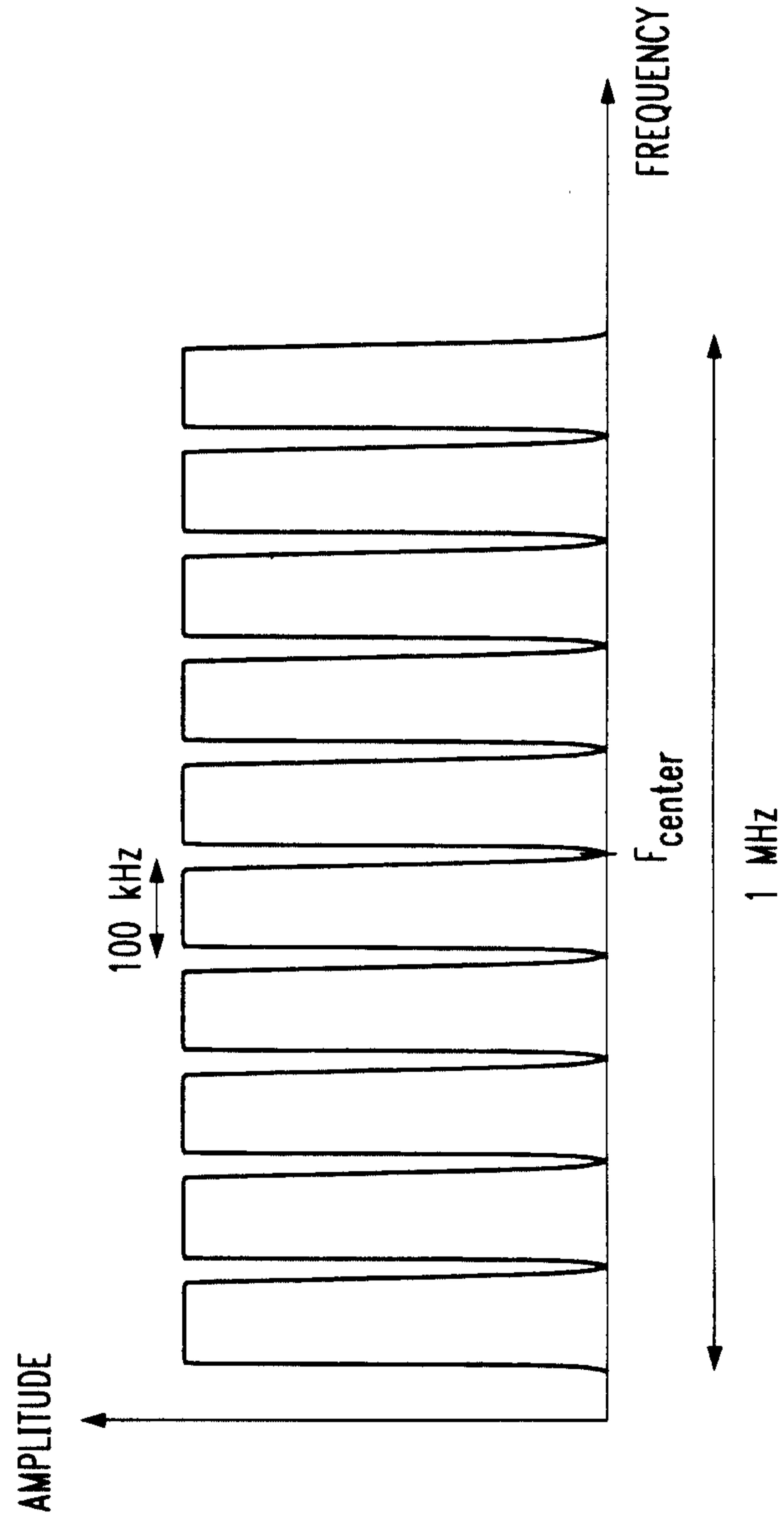

4/8

FIG. 4

ELEMENT SPACING = $\lambda/2$

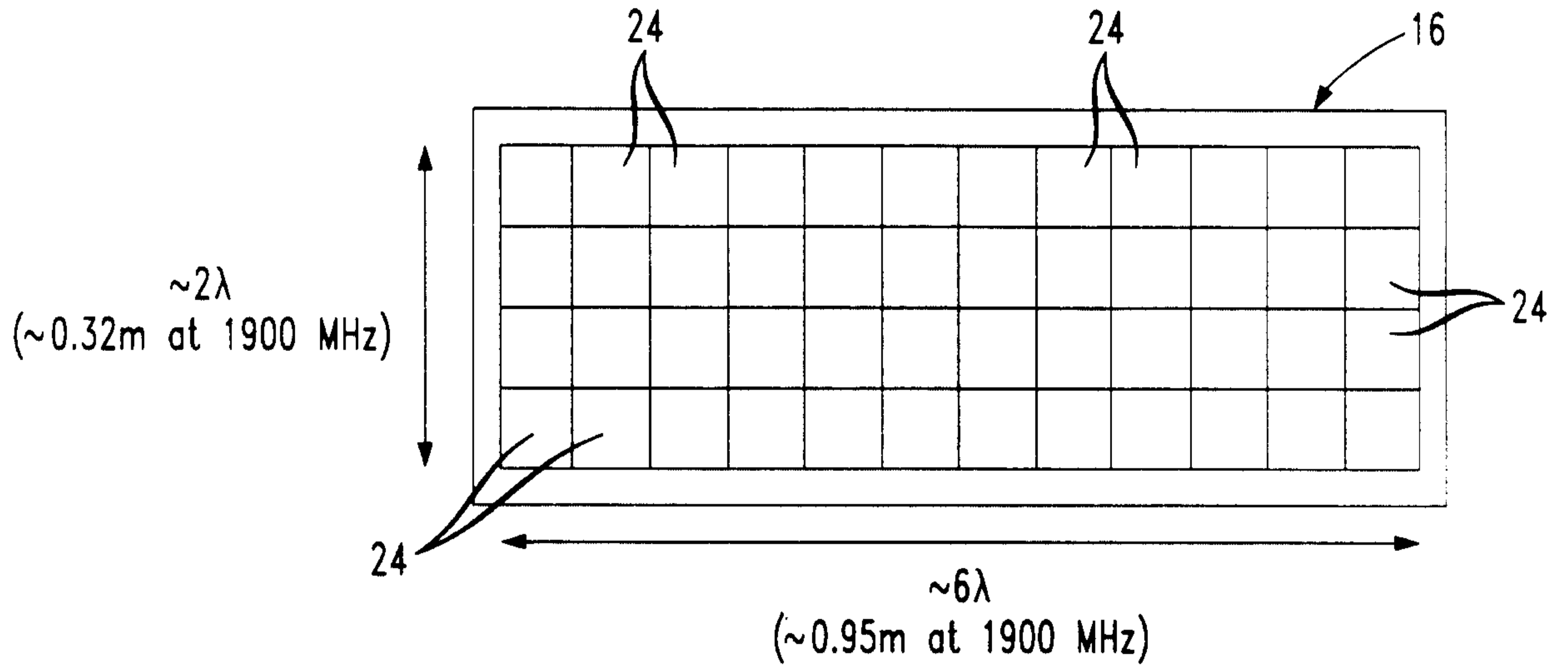

FIG. 5

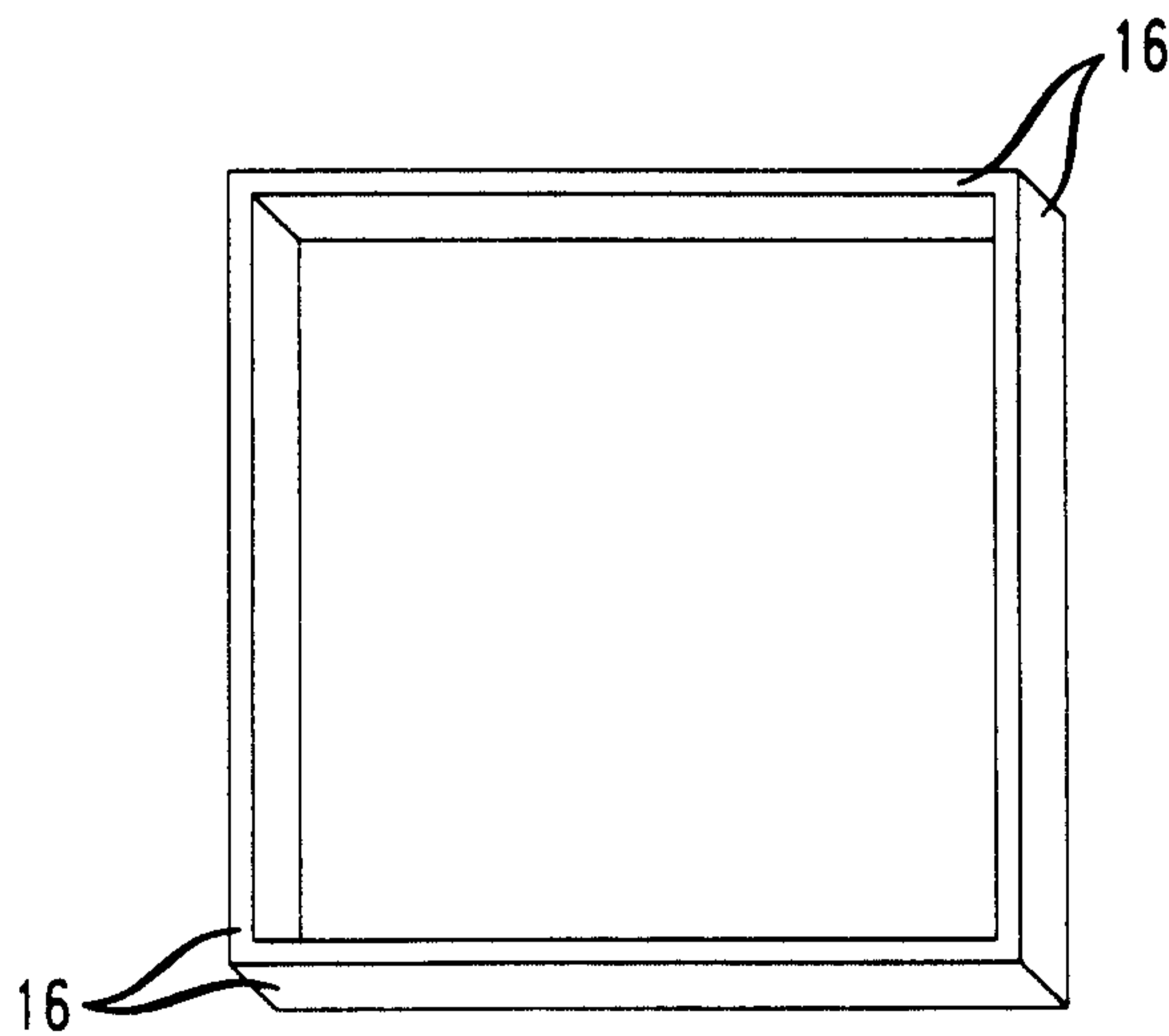

FIG. 6

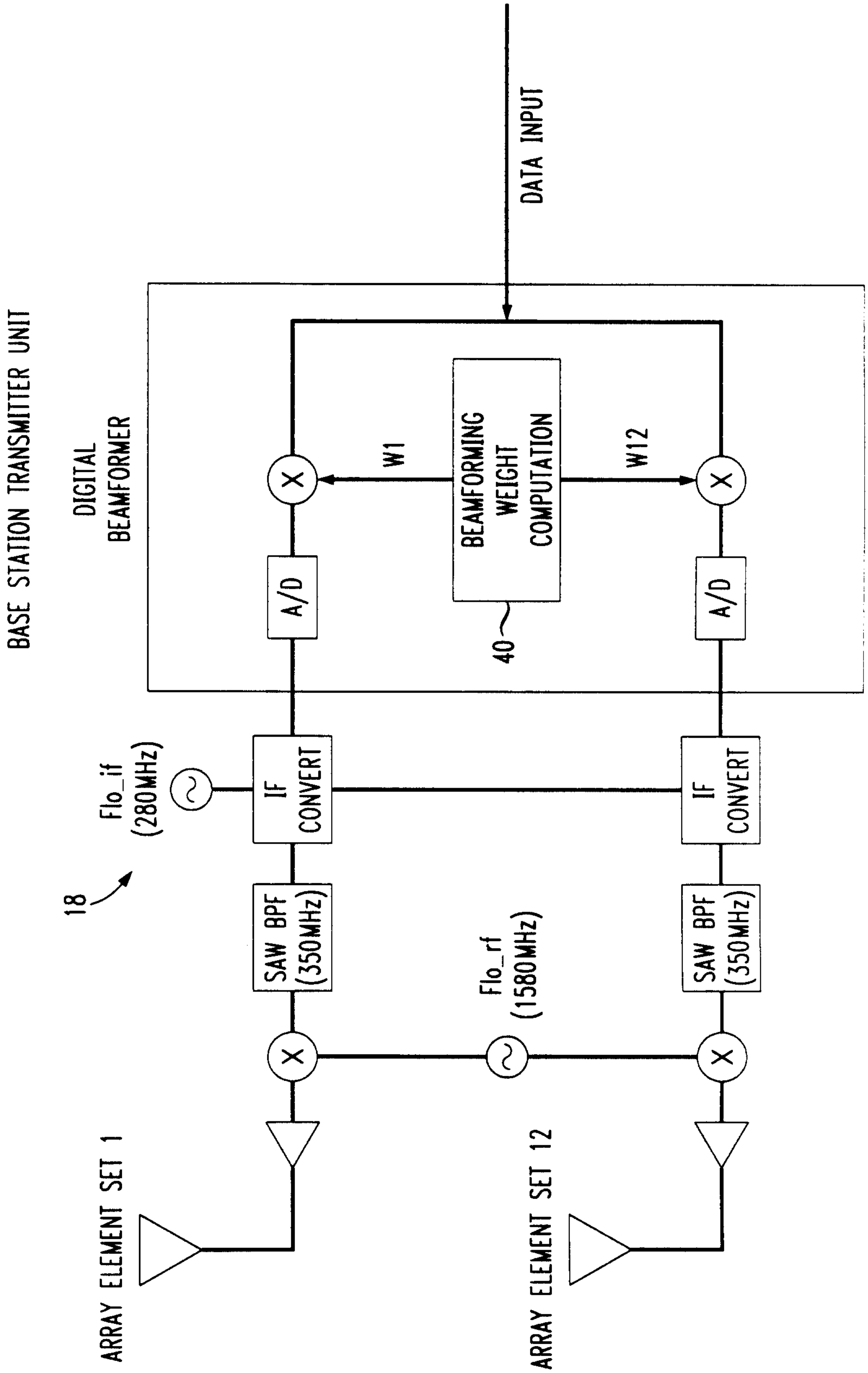

FIG. 7

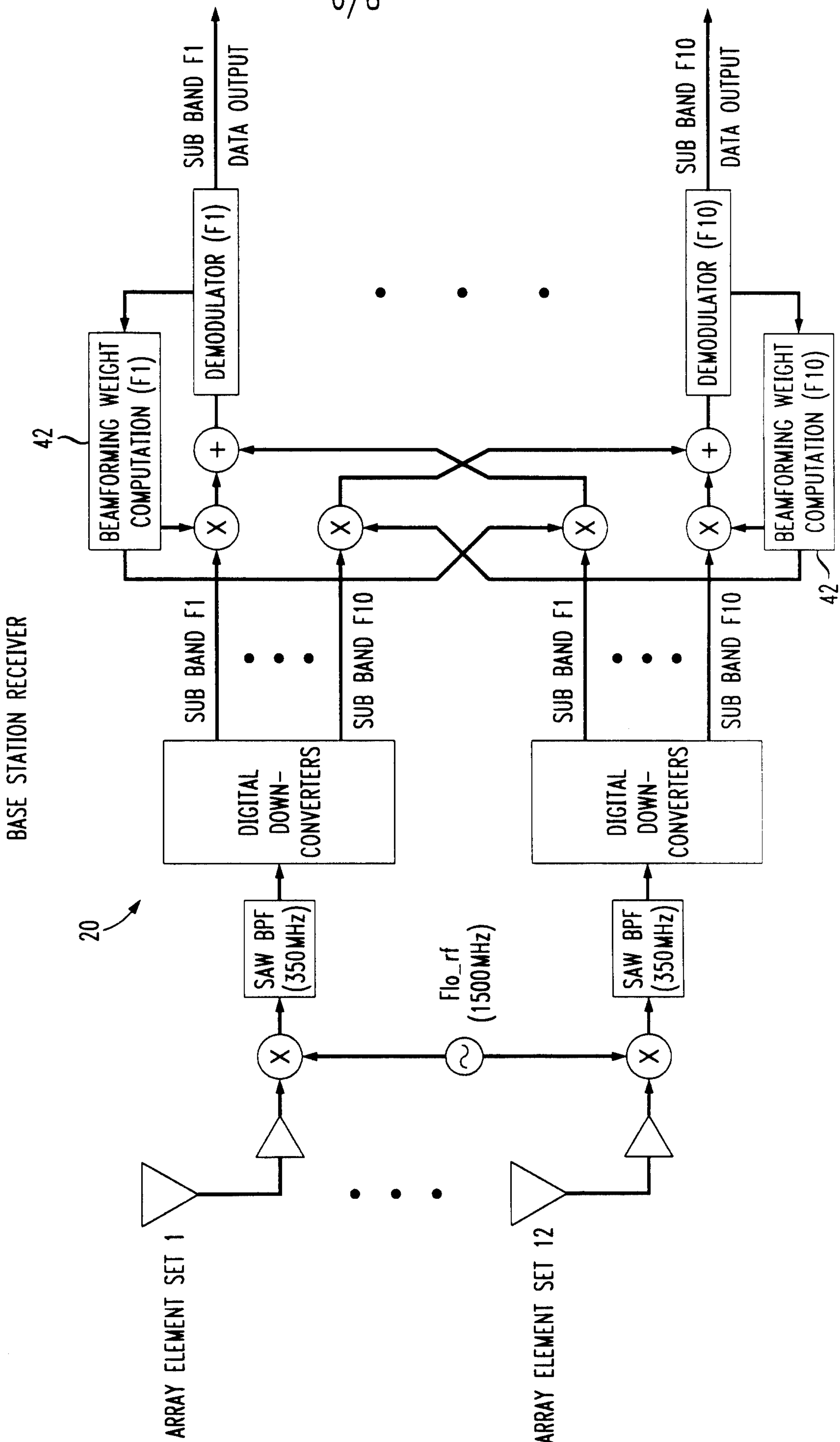

FIG. 8

SUBSCRIBER TRANSCIEVER

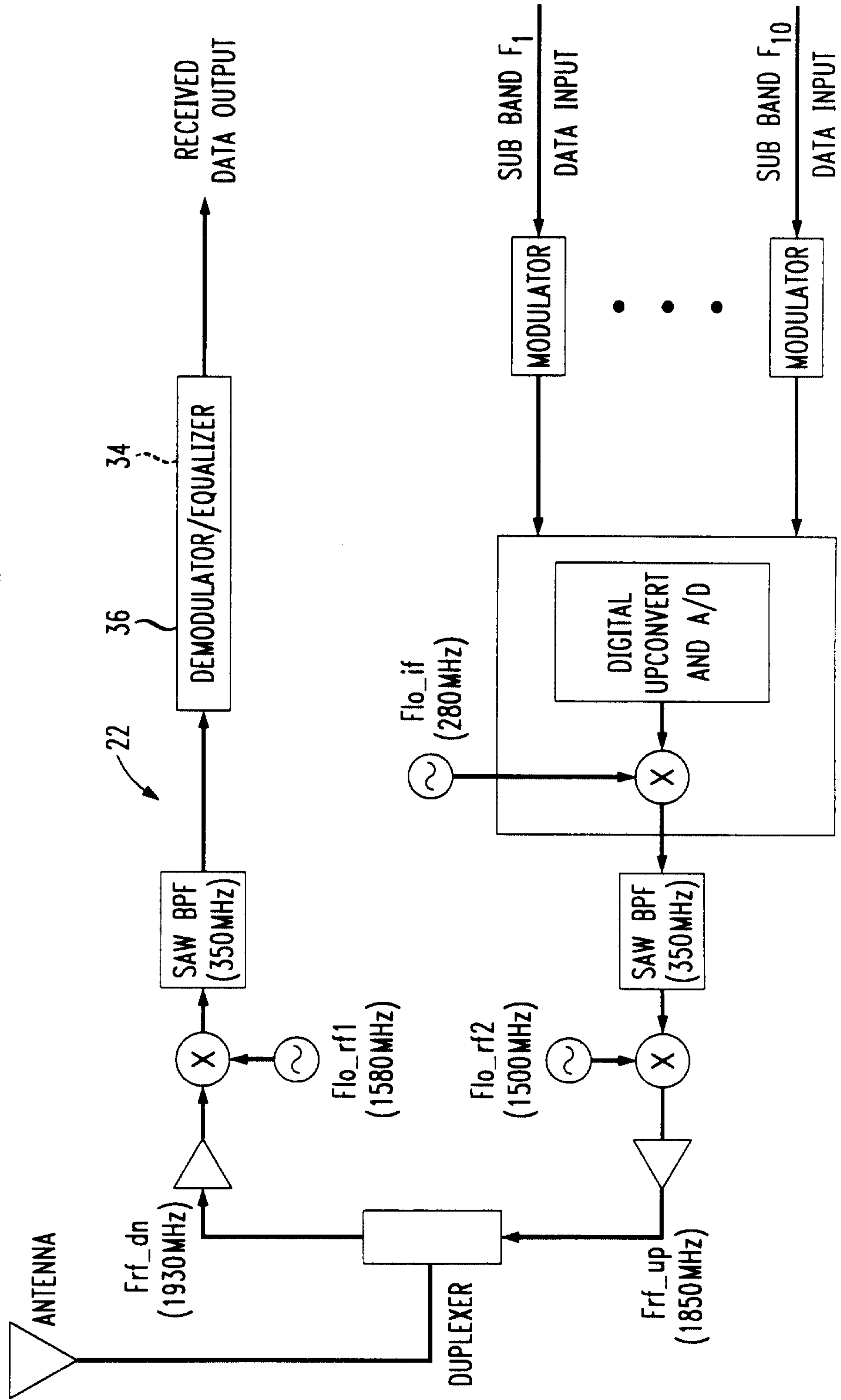

FIG. 9

