

A. O. BOHEM.
 WINDOW VENTILATOR.
 APPLICATION FILED AUG. 26, 1914.

1,200,302.

Patented Oct. 3, 1916.

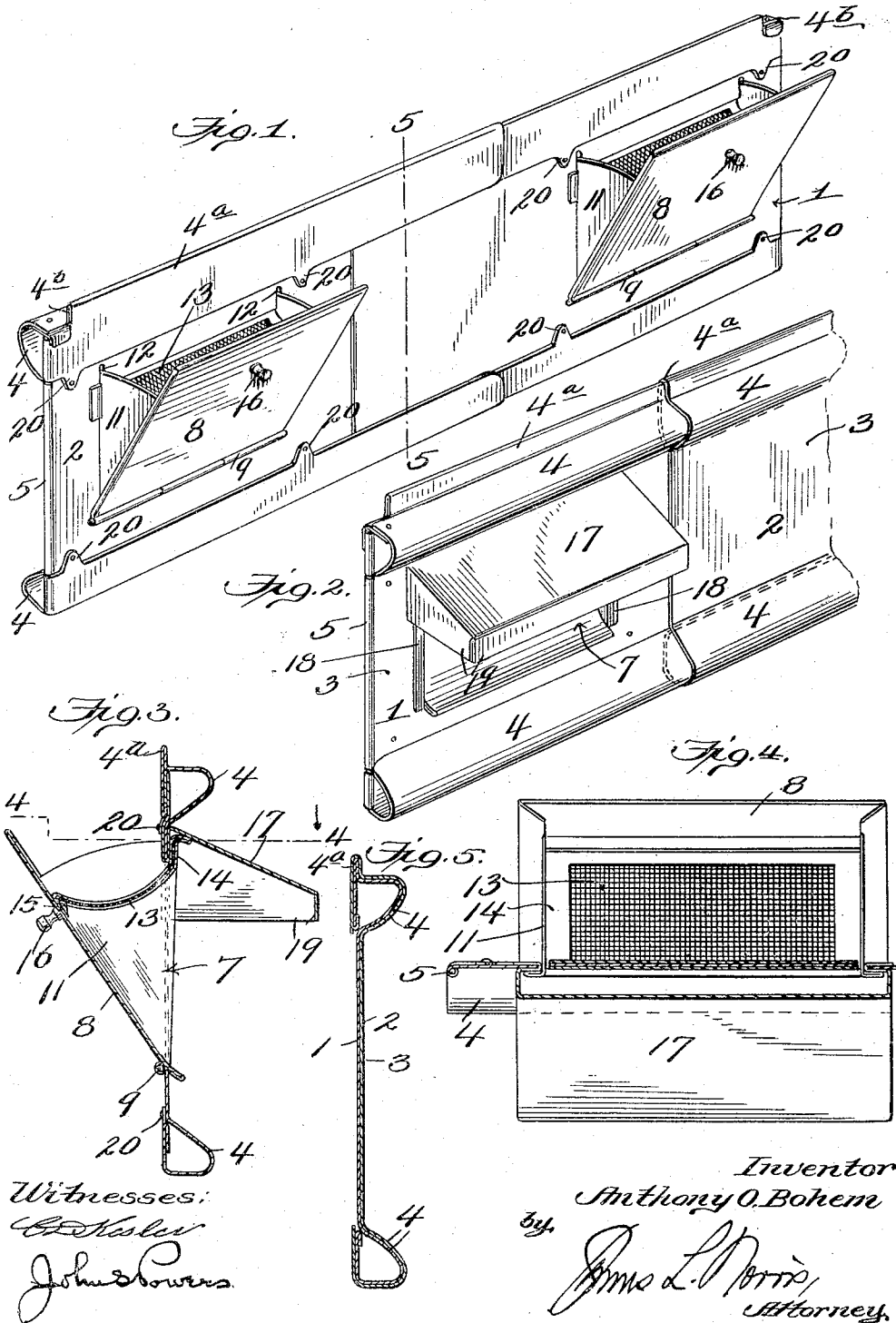

Witnesses:
Charles
John Powers

Inventor
Anthony O. Bohem
 by *James L. Norris*
 Attorney.

UNITED STATES PATENT OFFICE.

ANTHONY O. BOHEM, OF PHILADELPHIA, PENNSYLVANIA.

WINDOW-VENTILATOR.

1,200,302.

Specification of Letters Patent.

Patented Oct. 3, 1916.

Application filed August 26, 1914. Serial No. 858,686.

To all whom it may concern:

Be it known that I, ANTHONY O. BOHEM, a citizen of the United States, residing at Philadelphia, in the county of Philadelphia and State of Pennsylvania, have invented new and useful Improvements in Window-Ventilators, of which the following is a specification.

This invention relates to improvements in ventilators, proposing a device which is intended for operative combination with a window to insure a constant admission of fresh air into the room, notwithstanding that the window is closed and to provide for a distribution of the air in a manner to avoid direct drafts upon the occupants of the room.

More particularly the invention proposes an improvement upon the construction shown in my U. S. Letters Patent No. 1,116,226 of November 3, 1914.

The present ventilator secures all the advantages of my prior construction and has the further advantages of increased strength, weather proof engagement with the window, greater facility in its operative combination with the window, non-liability to displacement from its operative position, increased protection against moisture or rain, and a stronger and more reliable retention of the ventilating shutters in their various positions of adjustment.

An embodiment of the invention is illustrated in the accompanying drawings wherein:—

Figure 1 is a perspective view of a window ventilator in which the features of the invention are incorporated; Fig. 2 is a similar view showing the reverse side of the ventilator; Fig. 3 is a vertical sectional view through one of the air regulating shutters; Fig. 4 is a horizontal sectional view on the line 4—4 of Fig. 3, and Fig. 5 is a vertical sectional view on the line 5—5 of Fig. 1.

Similar characters of reference designate corresponding parts throughout the several views.

The ventilator shown and preferred is adjustable in order that it may be accurately fitted to windows of different widths. It will be understood, however, that certain features of the invention, more especially those involving the construction and arrangement of the air-regulating shutter and its appurtenances, may, be practised in con-

nection with a non-adjustable ventilator as well as with an adjustable one.

The ventilator shown in the drawings, as in my prior construction referred to, is made in two counterpart sections, 1 and 2, which are telescopically related whereby the ventilator may be lengthened or shortened in accordance with the width of the window opening in which it is to be fitted. Each section of the ventilator preferably, as in my said prior construction, comprises a sheet metal body 3 having along its upper and lower sides hollow beads 4 which preferably have a generally triangular cross section. The beads 4 are formed integrally with the body 3 and the portions thereof which coincide or substantially coincide with the plane of said body, are disjointed from the body, at least in the case of the section 2 whose beads 4 fit over the beads of the section 1. The beads 4 provide upper and lower marginal reinforcements for the ventilator as well as for the telescoping relation of the ventilator sections. Said beads also provide a relatively flat and wide bearing for the bars of the window frame and the window sash contiguous thereto.

According to the present invention the upper beads 4 are provided at their front edges with upwardly directed flanges or extensions 4^a, co-planar with the sections 3. The flange 4^a of the section 2 is of greater width than the flange 4^a of the section 1 and is of channeled cross section to fit over said latter flange in the same manner that the bead 4 of the section 2 fits over the bead 4 of the section 1. The flanges 4^a are preferably formed by bending the blanks upwardly at the front edges of the beads 4 and by overturning the upwardly bent portions along a line suitably distant from the upper faces of the beads 4 into or substantially into the planes of the bodies 3. In this way each flange 4^a consists of parallel thicknesses of metal integrally connected along a common upper edge. The flanges 4^a thus provide a substantial reinforcement for the ventilator along the upper edge thereof. The principal purposes of the flanges 4^a, however, are to bear with substantially weather proof tightness, against the front face of the lower bar of the lower sash when the ventilator is fitted in the window and to thus serve the office of weatherstripping in preventing the escape of air or moisture

into the room through the space between the lower window sash and the upper edge of the ventilator; and to prevent any accidental displacement of the ventilator outwardly from the window opening. Through warping of the window or sash frame or irregular or defective jointure of the sash bars it may happen that the lower bar of the sash will not have a uniform or accurate fit upon the upper faces of the upper beads 4 and it is in such cases that the flanges 4^a are particularly useful, since, as above explained they serve the function of weatherstripping and at the same time eliminate the necessity of using any conventional weather stripping.

To insure the accurate fitting of the ventilator in the window opening the flanges 4^a are cut away at their ends, as at 4^b, sufficiently to be clear of the inner side beads of the window frame.

The sections 1 and 2 are reinforced at their outer ends by suitably constructed vertical marginal flanges or beads 5. The flanges or beads 5 provide bearing surfaces at the ends of the ventilator for the window frame bars contiguous thereto and extend throughout the vertical depth of the ventilator, being formed along the ends of the beads 4 as well as the bodies 3.

As in my said prior construction, the beads 4 of the section 2 are of slightly greater dimensions than the beads 4 of the section 1 and the latter telescopes within the former, as shown in Figs. 1 and 2, in which relation the body 3 of the section 1 overlies, and, hence, partly conceals from within the room the body 3 of the section 2. The overlying portions of the sections bear with considerable frictional pressure against one another and therefore, the sections are not liable to any accidental relative movements which would disturb the adjustment thereof. To adjust the sections all that is required is to move them outwardly or inwardly relatively to one another for the purpose of lengthening or shortening the ventilator, as the case may be. When once adjusted, the frictional fit of the overlying portions of the sections will, as above stated, prevent any accidental disturbance of the adjustment.

The general arrangement and construction of the means for admitting and controlling the air is similar to my said prior construction in that such a means is preferably associated with each section of the ventilator where, as in the embodiment disclosed, the ventilator is made in adjustably related sections, and consists essentially of a shutter 8 controlling an opening 7 and hinged at its lower side, as at 9, to the body 3 along a line coincident with the lower edge of the opening 7. The shutter 8 in order to efficiently close the opening 7 when the use of the ventilator is not desired, is

made longer and deeper than said opening and thus overlies the portions of the ventilator contiguous to the opening at the sides and upper edges thereof. The shutter 8 has, at its sides, wings 11 which, in any open position of said shutter close the space between the same at its sides and the body of the ventilator. The wings 11 project through the opening 7, working in close relation to the sides of said opening and their upper portions, also project through vertical slits 12 which are formed in the bodies 3 at the upper sides and at the ends of the openings 7.

If desired the shutter 8 may be formed as a frame and provided with a glass panel for the admission of light.

In order to prevent the passage of dirt or foreign particles, such, as scraps of leaves or paper, into the room with the air passing through the opening 7, the shutter 8 carries at its rear side a screen 13 of fine mesh wire mounted in a rectangular frame 14. The frame 14 has at its forward side an attachment flange 15 and the shank of the knob 16 by which the shutter is manipulated preferably projects through and aids in securing said attachment flange to the shutter.

The passage of precipitated moisture into the room with the in-flowing air is prevented by a guard flange or hood 17 which projects rearwardly from the shutter at the upper side of the opening 7.

In order to limit the outward movement of the shutter 8, *i. e.*, the movement of the shutter away from the body of the ventilator, the wings 11 are provided at their rear edges with out-turned flanges 18 which in the course of the outward movement of the shutter ultimately engage the rear face of the ventilator and prevent a further continuation of said outward movement.

The volume of air admitted into the room of course depends on the position of the shutter 8 and is controlled by a suitable adjustment of said shutter as is obvious. Accidental displacement of the shutter from any position to which it may be adjusted is prevented by reason of the frictional binding of the wings 11 against the sides of the opening 7 and of the frame 14 against the guard flange or hood 17, the said frame being constructed of springy or resilient metal and tending to spring against said guard flange.

According to the present invention the frame 14 has a dished cross section, its concave side being presented upwardly and the outer bar of said frame bears with strong frictional pressure against the under face of the flange 17; and said flange 17 is inclined downwardly from the ventilator and preferably has a straight cross section. By virtue of these features of relation, it is assured that the frame 14 shall have such

frictional engagement with the guard 17 as to reliably prevent any accidental displacement of the shutter 8 from any adjusted position thereof. The guard 17 according to the present invention, has a depending marginal apron 19 extending along the sides and outer edges thereof and provided to prevent rain or snow from beating in under the guard 17 through the opening 7.

10 The beads 4 are provided at appropriate intervals with tabs 20 which are secured by rivets or otherwise to the bodies 3.

The ventilator is fitted in the window opening in the plane of the lower sash and against the inner beads of the window frame. The beads 4^a however, are, as above explained, provided with the cutaway portions 4^b at their ends and are arranged to extend between the inner side beads of the window frame and to bear closely against the inner face of the lower bar of the lower sash.

Having fully described my invention, I claim:—

25 1. A window ventilator comprising slidably related counterpart sheet metal sections having relatively flat body portions and hollow telescoping beads along the upper edges of said body portions, the beads being formed along their front edges with relatively thin upwardly projecting telescoping flanges arranged substantially in the plane of said body portions, as and for the purpose set forth.

35 2. A window ventilator comprising slidably related counterpart sheet metal sections having relatively flat body portions

and hollow telescoping beads along the upper edges of said body portions, the beads being formed along their front edges with upwardly projecting telescoping flanges arranged substantially in the plane of said body portions and the flanges being cut away at their ends short of the ends of the ventilator, as and for the purpose set forth.

3. A window ventilator comprising a body formed to fit under a window sash and to extend across the window opening and having an air admission opening, a shutter hinged adjacent the lower edge of said air admission opening and arranged at the interior side of the ventilator, the shutter in any open position thereof projecting forwardly and upwardly into the room, a screen associated with the shutter, a springy dished rectangular frame carrying the screen and secured to the shutter, the frame projecting rearwardly from the shutter and presenting its concave side upwardly and a flange projecting rearwardly and downwardly from the upper edge of the air admission opening of said body, the screen carrying frame tending to spring upwardly and being arranged whereby its outer bar bears with strong frictional pressure against the flange to hold the shutter against displacement.

In testimony whereof I have hereunto set my hand in presence of two subscribing witnesses.

ANTHONY O. BOHEM.

Witnesses:

H. M. McBurney,
D. H. McBurney.

Copies of this patent may be obtained for five cents each, by addressing the "Commissioner of Patents, Washington, D. C."