

(No Model.)

E. TILMANN.
MAGNETO ELECTRIC MACHINE.

No. 523,247.

Patented July 17, 1894.

Fig:1.

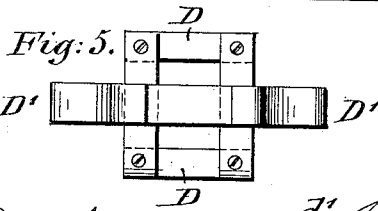
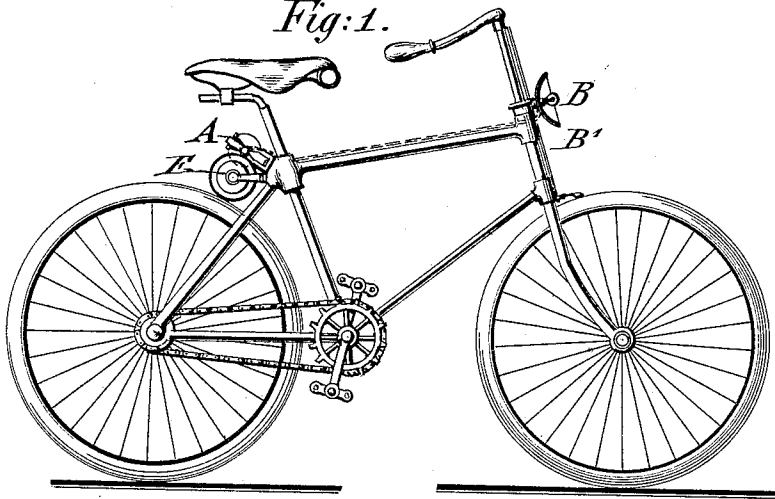

Fig:2. A'

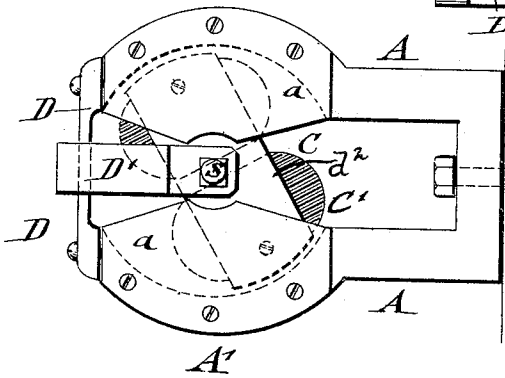

Fig:3.

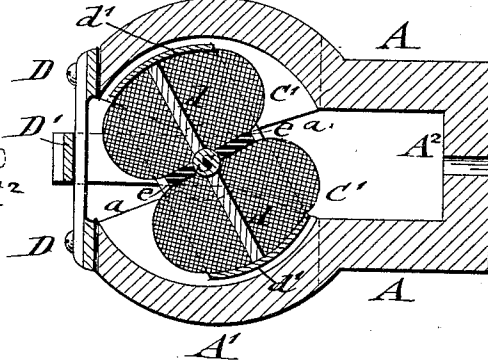
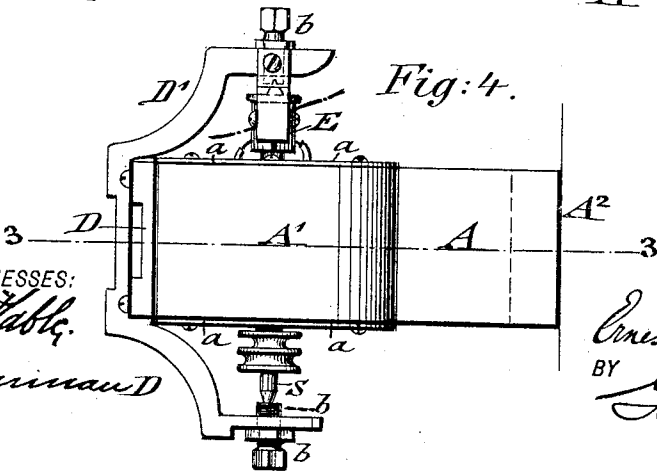

Fig:4.



WITNESSES:

Carl Kable.
H. B. Brinnan

INVENTOR

Ernest Tilmann
BY *Joseph R. Rogers*
ATTORNEYS.

UNITED STATES PATENT OFFICE.

ERNEST TILMANN, OF NEW YORK, N. Y., ASSIGNOR OF ONE-HALF TO CHARLES K. LEXOW, OF SAME PLACE.

MAGNETO-ELECTRIC MACHINE.

SPECIFICATION forming part of Letters Patent No. 523,247, dated July 17, 1894.

Application filed November 22, 1893. Serial No. 491,638. (No model.)

To all whom it may concern:

Be it known that I, ERNEST TILMANN, a citizen of the Republic of France, residing in the city, county, and State of New York, have invented certain new and useful Improvements in Magneto-Electric Machines, of which the following is a specification.

This invention has reference to a magneto-electric machine, which is intended for the purpose of supplying a current of high intensity to a miniature incandescent lamp, said dynamo and lamp being used in connection with a bicycle, cab and other vehicle and operated, so as to supply the current when the vehicle is in motion, and the invention consists of a magneto-electric machine, the permanent magnet of which is provided with arc-shaped pole-pieces that are provided at opposite sides with segmental pole-plates, said pole-pieces and plates exerting an inductive action on the coils of the armature, so as to generate induction-currents in the same. The shaft of the armature is supported in bearings of a non-magnetic frame, that is preferably cast in one piece and attached to the ends of the pole-pieces, said armature-shaft being provided with a commutator for the coils and with brushes by which the current is conducted to the miniature electric lamp to be lighted. The armature is formed of a diametrical core and core-plates adjacent to the pole-pieces of the magnet, as will be fully described hereinafter and finally pointed out in the claims.

In the accompanying drawings, Figure 1 represents a side elevation of a bicycle, shown with my improved magneto electric machine applied thereto, and connected with an electric incandescent lamp, at the front part of the frame. Fig. 2 is a side-elevation of the magneto-electric machine, drawn on a larger scale. Fig. 3 is a vertical longitudinal section of the same, on line 3—3, Fig. 4. Fig. 4 is a top-view of the same, and Fig. 5 is a detail plan-view of the frame for supporting the armature-shaft, drawn on a smaller scale.

Similar letters of reference indicate corresponding parts.

Referring to the drawings, A represents a permanent field-magnet having arc-shaped pole-pieces A' of my improved magneto-electric machine.

The pole-pieces A' are made integral with the U-shaped base A² of the magnet by which base the machine is attached at any suitable point on the velocipede, cab or other vehicle.

A miniature incandescent lamp B is connected by conducting wires with the magneto-electric machine, the latter being built in such proportion as to supply a current of sufficient strength and intensity to bring the filament of the miniature incandescent lamp to incandescence. As a miniature lamp would not supply the required quantity of light, a parabolic reflector B' is used, by which the light-giving effect of the incandescent lamp is enhanced to the required degree and the light thrown in the direction required.

The arc-shaped pole-pieces and the base of the magnet A are preferably made of suitable cast-steel to which the required degree of magnetism is imparted in the usual well-known manner, so that a permanent magnet is formed thereby. The sides of the arc-shaped pole-pieces A' are provided with pole-plates *a*, which are made of approximately segmental shape, so as to extend toward the shaft S of the armature C, which is located in the magnetic field formed by the pole-pieces.

The pole-plates *a a* inclose the ends of the armature, and as they are also permanently magnetized they exert an inductive action on the ends of the coils wound on the armature, while the pole-pieces A' exert an inductive action on the longitudinal portions of the coils. The shaft S of the armature C is provided with conically-tapering ends, which are supported in adjustable bearings *b* having conical recesses for the ends of the shaft. The bearings *b* are arranged at the ends of the central portion D' of a supporting-frame D, which is made of rectangular shape and attached by screws or other fastening devices to the flat ends of the pole-pieces A', as shown clearly in Figs. 2, 3 and 4. The central portion D' and the rectangular portion D are preferably made in one integral casting of brass or other suitable non-magnetic material.

The armature C is provided with a diametrical core *d* around which two separate coils C' are wound, that are separated by a suitable insulating plate or partition *e* that is arranged

at right angles to the core \bar{d} , as shown in Fig. 3. Steel or iron core-plates \bar{d}' , which are concentric to the inner faces of the pole-pieces A' are applied to the ends of the core \bar{d} and extended over the sides of the coils, said plates being connected at the ends by diametrical end-plates \bar{d}^2 , which like the core-plates are alternately magnetized by the pole-pieces, so as to exert a very effective action on the windings of the coils, while the pole-plates at the ends of the pole-pieces exert an inductive action on the ends of the convolutions of the coils. The armature is rotated by any suitable transmission from one of the rotative parts of the vehicle.

In velocipedes, it is preferable to use an intermediate friction-disk F that is supported in suitable bearings of the frame and placed in contact with the tire of the rear-wheel, and a pulley on the shaft of the armature, as shown in Fig. 1.

Any other means for transmitting motion may be employed, as I do not desire to confine myself to the specific construction shown. It is necessary, however, to so proportion the motion-transmitting mechanism that sufficient speed is imparted to the armature so that a current of sufficient strength for the miniature-lamp is obtained as soon as the vehicle is set in motion, the increasing speed at which the vehicle is driven increasing also the quantity of the current. As soon as the vehicle is stopped, the armature is stopped and the generation of the current discontinued.

On the shaft of the armature is arranged a commutator E of any approved construction, by which the induction-currents generated in the coils of the armature are collected and changed into currents of uniform direction, they being taken up by brushes that are placed in contact with the commutator-segments in the usual manner and connected with the conducting wires leading to the light-giving lamp.

As the magneto-electric machine is of comparatively small size, it adds very little to the weight of the vehicle, while it supplies a light far superior to the ordinary oil lamps, but without the objectionable feature, such as a disagreeable smell and easy extinguishment of the same when passing suddenly over obstructions, &c., are obviated.

If desired to increase the strength of the current, the shanks of the magnet may be wound with coils into which a portion of the induced current from the armature is conducted so as to excite the same, whereby a miniature dynamo-electric machine is obtained.

Having thus described my invention, I claim as new and desire to secure by Letters Patent—

1. A magneto-electric machine, consisting

of a permanent magnet having arc-shaped pole-pieces, said pole-pieces being provided at opposite sides with inwardly-projecting pole-plates, an armature rotating in the space inclosed by the said pole-pieces and pole-plates, and a non-magnetic frame attached to the ends of the pole-pieces and provided with bearings for the shaft of the armature, substantially as set forth.

2. A magneto-electric machine, consisting of a permanent magnet having arc-shaped pole-pieces, segmental pole-plates attached to opposite sides of the pole-pieces and an armature rotating within the pole-pieces, and composed of a diametrical core, coils wound on said core and core-plates extending over said coils, substantially as set forth.

3. The combination, of a permanent magnet composed of arc-shaped pole-pieces and segmental plates attached to the opposite sides of said pole-pieces, an armature-supporting frame formed of a rectangular portion attached to the flat ends of the pole-pieces and a central portion provided with bearings, and an armature the shaft of which is supported in the bearings of the central portion, substantially as set forth.

4. The combination, of a permanent magnet having a U-shaped base portion and arc-shaped pole-pieces, segmental pole-plates attached to the sides of the pole-pieces, and extending toward the center of the magnet, a non-magnetic frame attached to the ends of the pole-pieces and provided with a central portion having bearings in its sides, and an armature the shaft of which is supported in said bearings and provided with coils wound on a diametrical core of the shaft and core-plates extending over the coils concentric to the pole-pieces, substantially as set forth.

5. A permanent magnet for magneto-electric machines, provided with arc-shaped pole-pieces and segmental pole-plates extending from the sides of the pole-pieces toward the armature-shaft, substantially as set forth.

6. An armature for magneto-electric machines, composed of a diametrical core, coils wound on said core, an insulating partition separating the coils and core-plates extending over the coils, substantially as set forth.

7. An armature for magneto-electric machines, composed of a diametrical core, coils wound on said core, an insulating partition between the coils, core-plates extending over the coils and diametrical end plates connecting said core-plates, substantially as set forth.

In testimony that I claim the foregoing as my invention I have signed my name in presence of two subscribing witnesses.

E. TILMANN.

Witnesses:

PAUL GOEPEL,
K. BRENNAN.