

Sept. 20, 1955

E. A. WILSON

2,718,445

BUMPER-TYPE CAMP TABLE

Filed May 17, 1954

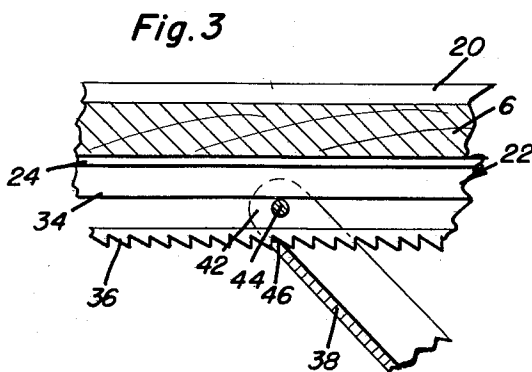
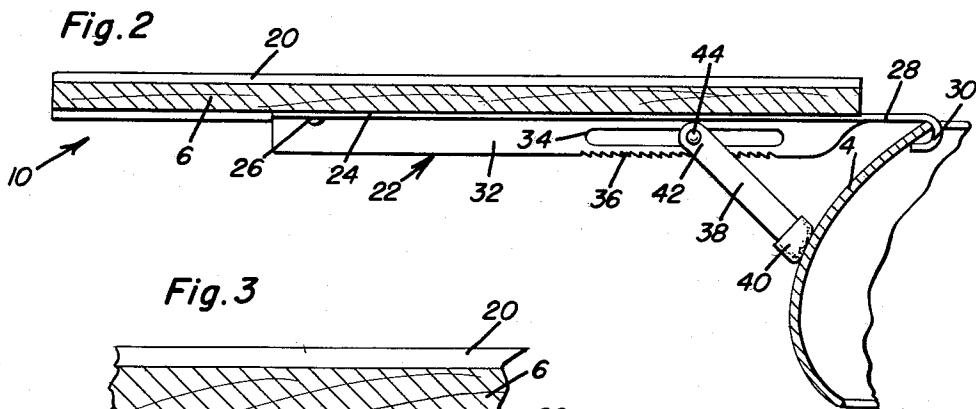
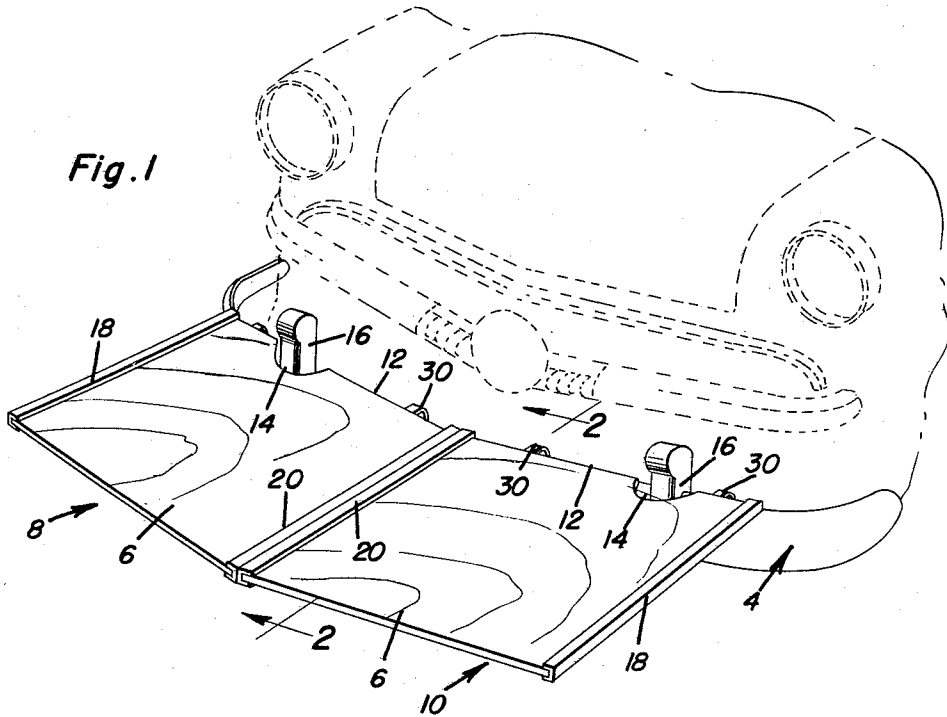

Ernest A. Wilson
INVENTOR.

BY *Alvanice A. O'Brien*
and Harvey E. Jackson
Attorneys

1

2,718,445

BUMPER-TYPE CAMP TABLE

Ernest A. Wilson, Butte, Mont.

Application May 17, 1954, Serial No. 430,253

1 Claim. (Cl. 311—21)

2

The present invention relates to a portable table construction of a handy knockdown type and has more particular reference to a construction which is expressly designed and therefore appropriately adapted for use by campers and others, at the beach or elsewhere, the same being unique in that it is attachable to and supported from an automobile bumper.

It is a matter of common knowledge that those who go in for touring, camping, picnics and out-of-doors activities have a special need for equipment which lends itself to practical usefulness in conjunction with an automobile. In the matter at hand it is believed that there has long existed a need for a table construction which may be handily carried in the trunk of an automobile and then expeditiously set up for use. To this end a sectional table is provided wherein means thereon makes it possible to hook the table to and support it from a conventional bumper, say for example, the rear bumper.

In carrying out the principles of the invention, a table construction is provided which is preferably made up of a pair of duplicate companion sections, said sections being hooked on the bumper and being arranged in edge-to-edge abutting relationship, and adjustable prop-like legs being provided to support said sections in a position in an approximate plane with the stated bumper.

Other objects, features and advantages will become more readily apparent from the following description and the accompanying sheet of illustrative drawings.

In the drawings:

Figure 1 is a perspective view of a bumper-type picnic or camper's table constructed in accordance with the principles of the invention and showing the manner in which the same is preferably used;

Figure 2 is a view in section on a larger scale which is taken on the line 2—2 of Figure 1 looking in the direction of the arrows; and

Figure 3 is a fragmentary view on a still larger scale showing certain of the structural details.

Referring now to the drawings, the automobile bumper, a conventional part, is denoted generally by the numeral 4 in Figure 2. The table is preferably a knockdown sectional type. It is, therefore, preferably made up of a pair of duplicate complementary sections. Each section comprises a flat rectangular wooden or equivalent panel 6. Although identical in construction the sections may be conveniently designated in Figure 1 as 8 and 10, respectively. It makes no difference, however, whether the sections are arranged to the right or left since they are, as stated, of duplicate construction and may be handily applied either way. It is notable, however, that in many instances clearance notches may have to be formed in the edge portions 12—12, the notches being denoted by the numerals 14 and serving to accommodate the bumper guards 16—16. For rigidity, appropriate edging or binding members may be provided and these are denoted by the numerals 18—18 and 20—20, respectively, with the latter ones 20, abutting one another. Attaching devices

are provided for each panel and they are arranged in pairs on the bottom of each panel. Each device is the same in construction and a description of one will suffice for all. The numeral 22 designates a linearly straight angle iron whose horizontal flange 24 is fastened at 26 to the underneath side of the panel. This flange has an extension 28 at one end which is formed into a hook 30 which engages over the upper edge of the bumper in the manner shown in the drawings. The vertical flange 32 is provided with an elongated slot 34 with the adjacent edge portion of the flange having serrations defining teeth 36. There is a channel-shaped prop or leg and this is denoted by the numeral 38 and it has a rubber or equivalent rest or foot 40 which rests against the bumper. Being channel-shaped and bifurcating the upper end of the leg, spaced parallel ears 42 are thus provided and these ears are in turn provided with a pin 44 which extends through the slot. The adjacent web portion near the pin and ears forms a sort of retaining tooth 46 and this is selectively engageable with the teeth 36 whereby to provide a slideable-type retaining connection between the leg and the angle iron.

These legs can be folded, or if desired, they can be made detachable depending on just how the manufacturer decides to approach the problem. In any event, the average "table" will be made up of rectangular panel sections arranged in abutting relationship and having hook means to engage over the bumper. In addition, the adjustable braces or legs are provided and consequently a satisfactory two-part table is had. This sort of a table can be carried in the trunk of the automobile, the lid of which is shown at A in Figure 1. Actual practice has shown that a table of this construction can turn out to be an extremely handy device. It has served in a highly practical manner and can be produced at an extremely low cost for equally low priced marketing. In practice, all that one has to do is to open the trunk, take up the table, set it up in the manner shown. Assuming that the rest of the picnic equipment is in the trunk, it can be easily lifted out, placed on the table and the table used in any convenient way.

From the foregoing, the construction and operation of the device will be readily understood and further explanation is believed to be unnecessary. However, since numerous modifications and changes will readily occur to those skilled in the art, it is not desired to limit the invention to the exact construction shown and described, and accordingly all suitable modifications and equivalents may be resorted to, falling within the scope of the appended claim.

What is claimed as new is as follows:

An out-of-doors bumper-type camping table comprising in combination, a rigid table-forming panel, means for detachably and rigidly securing one edge portion of said panel to an upper edge portion of an automobile bumper so that the panel extends horizontally from the bumper and then functions as a temporarily useable camp table, said means embodying at least one angle iron having vertical and horizontal flanges, said horizontal flange being superimposed against and fixedly secured to the bottom surface of said panel, said horizontal flange terminating in a return-bend functioning as an attaching and retaining hook for said panel, said return-bend projecting beyond the cooperating marginal edge of said panel, said vertical flange having a horizontally elongated slot therein situated wholly beneath the panel and inwardly of the stated one edge of said panel, the lower edge of said vertical flange being serrated to provide retaining teeth, a bumper engaging leg of channel-shaped form having an upper portion bifurcated and defining furcations, said furcations straddling said slotted flange, the adjacent bight portion of the channel co-

operating with said furcations and providing a crotch forming a tooth, the latter being selectively engageable with the retaining teeth, a pin fixed to the furcations and straddling the space therebetween, said pin being confined for operation in said slot, and a foot on the free lower end of said leg engageable with the stated bumper.

5

10

818,004
1,534,095
1,641,358
1,743,406
1,788,800
1,817,056
2,195,366
2,645,537

References Cited in the file of this patent

UNITED STATES PATENTS

Thornton, Jr. -----	Apr. 17, 1906
Walker -----	Apr. 21, 1925
Smyser -----	Sept. 6, 1927
Stone -----	Jan. 14, 1930
McGinley -----	Jan. 13, 1931
Belgard -----	Aug. 4, 1931
Haigh -----	Mar. 26, 1940
Brath et al. -----	July 14, 1953