

May 8, 1962

N. H. SOULSBY

3,033,105

PRESSES

Filed May 4, 1960

2 Sheets-Sheet 1

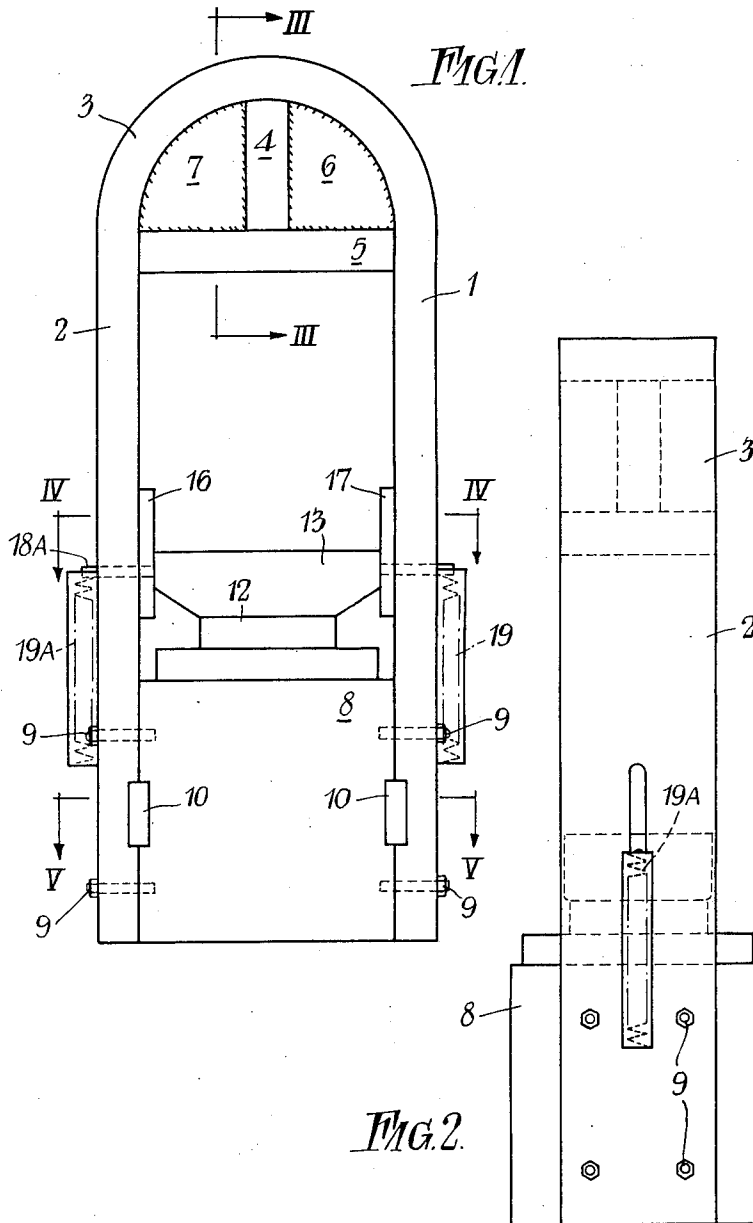

May 8, 1962

N. H. SOULSBY

3,033,105

PRESSES

Filed May 4, 1960

2 Sheets-Sheet 2

FIG. 3.

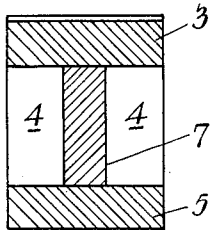

FIG. 4.

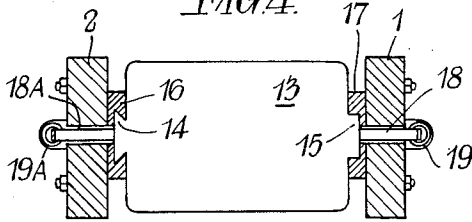

FIG. 5.

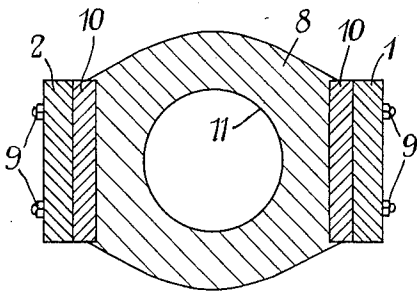
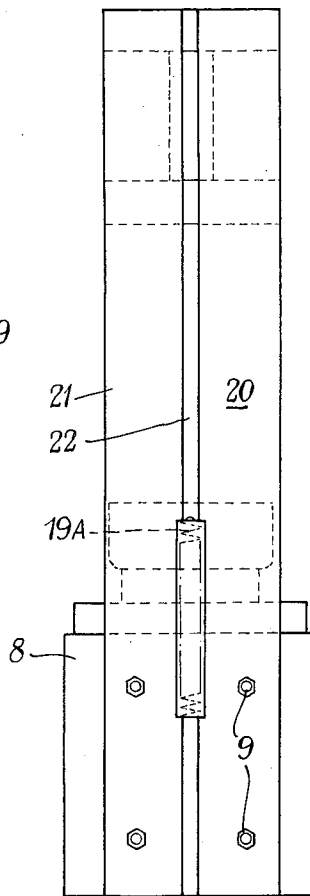

FIG. 6.



1

3,033,105
PRESSES

Norman Henry Soulsby, Charlton, London, England, assignor to William Jones Limited, London, England, a British company

Filed May 4, 1960, Ser. No. 26,804

Claims priority, application Great Britain May 6, 1959
6 Claims. (Cl. 100—214)

This invention relates to presses and has for its object to provide a press which will have a robust yet simple frame construction. Where presses are required for relatively high capacity operation, the head and base of the press must be interconnected by a frame which will not distort. Such frame of necessity will include members which extend longitudinally in the direction of the stroke of the press and which will be subject to tension. The head of the press, which connects the longitudinally extending members, will be subject to bending. To build a frame which will withstand the effects of tension and bending when the press is in use presents a problem which is not easy of solution and tends to lead to considerable expense.

It is an object of the invention to provide a press wherein the frame includes at least one arch, the straight limbs of which are arranged to withstand the tensile forces set up in the employment of the press and a curved portion of which encloses and has secured thereto a structure which resists the bending moments in the frame which arise in the use of the press.

For a better understanding of the invention and to show how the same may be carried into effect, reference will now be made by way of example to the accompanying drawings in which:

FIGURE 1 is a diagrammatic front elevation of a press,

FIGURE 2 is a side view corresponding to FIGURE 1,

FIGURE 3 is a section taken on the line III—III of FIGURE 1,

FIGURE 4 is a sectional plan taken on the line IV—IV of FIGURE 1,

FIGURE 5 is a sectional plan taken on the line V—V of FIGURE 1, and

FIGURE 6 is a view similar to FIGURE 2 but showing a modification.

As will be seen from FIGURES 1 to 5, the press essentially consists of a frame formed as an arch having two parallel limbs 1 and 2 and a substantially semicircular curved portion 3. As will be seen from FIGURES 1 and 2, the arch is formed from a massive, oblong-rectangular section, strip, the side faces of which (see FIGURE 2) are of greater width than the edges thereof (see FIGURE 1). The semi-circle of the arch is centered about a line parallel to a side face of said strip, the line being contained in a plane perpendicular to the planes containing the edges of the strip. The inner side of the curved portion 3 of the arch has a massive strut 4 secured therein, the upper part of the strut abutting and being welded to the center of the portion 3 and the lower part abutting and being welded to a head plate 5 which is also secured between the limbs 1 and 2 of the frame. The strut 4 extends substantially from edge to edge of the curved portion 3 and substantially parallel to the limbs 1 and 2. Web plates 6 and 7 lie in the openings between the strut 4, the head plate 5 and the internal curved wall of the portion 3.

Between the lower ends of the limbs 1 and 2 a base block 8 is inserted. The block 8 is held in position with studs 9, and keys 10 which may, if desired, be integral with the block. The block 8 has a bore 11 (see FIG. 5), the lower end of which is closed to form a cylinder for the reception of a ram 12. With the aid of mechanism not shown, hydraulic pressure media may be admitted to

2

or withdrawn from the cylinder so as correspondingly to raise the ram 12 or allow the same to fall. The upper end of the ram 12 carries a platen 13, one side of which is formed with a dovetail block 14 (see FIG. 4), the other side being formed with a simple rectangular-section block 15. The dovetail block 14 is entered in a correspondingly shaped slideway 16 fitted on the inside of the limb 2, and the block 15 is likewise received in a slideway 17 fitted on the inside of the limb 1. If desired, the platen 13 may be formed either with two dovetail blocks similar to 14 or with two rectangular blocks similar to 15. In either case, the slideways would of course be shaped to correspond with the blocks. The limbs 1 and 2 and the slideways 16 and 17 are slotted to receive pins 18 and 18A which are affixed to the blocks 15 and 14 respectively. (The slot in the limb 2 may be seen in FIG. 2.) The free end of the pin 18 is connected to the upper end of a vertical spring 19 and the free end of the pin 18A is similarly connected to a vertical spring 19A, the springs being arranged in tubes which are disposed on the outside surfaces of the limbs 1 and 2 and which are slotted to receive the pins. The lower ends of the springs 19 and 19A are anchored to the lower parts of the limbs 1 and 2 respectively.

In the employment of the press so far described, it will be understood that appropriate tooling is arranged upon the head plate 5 and the platen 13. In FIGURE 1 the platen 13 is shown in its lowest position. When hydraulic pressure medium is caused to enter the cylinder formed in the base block 8, the ram 12 will be raised, the platen 13 being guided with the aid of the slideways 16 and 17. As the platen moves upwardly and, with the aid of interposed tooling, engages the work and produces a corresponding reaction from the head plate 5, the limbs 1 and 2 will be brought into tension. The limbs 1 and 2 are massive in construction and since they extend in the direction of the line of action of the tension, their shape is good for withstanding such tension. Additionally there will be a bending moment applied to the head plate 5. This head plate is however effectively an integral part of the beam structure which includes the curved portion 3 of the arch, the web plates 6 and 7 and the massive strut 4, and it will be appreciated that the greatest bending moment will occur at the location of the strut 4, i.e. at the position of greatest vertical section of the beam structure. Hence there will be a very high resistance to the bending moment, and distortion of the press frame will not occur with even quite high loadings for the press. As the platen 13 moves upwardly, the springs 19 and 19A are tensioned. When the hydraulic pressure medium is allowed to leave the cylinder formed in the base block 8, the springs 19 and 19A aid the platen 13 and the ram 12 in their downward movement. Hence the speed of the return-stroke of the press is increased.

Instead of employing a single arch as described in connection with FIGURES 1 to 5, a double arch construction could be employed as shown in FIGURE 6. Here there are two arches 20 and 21 placed one against the other so that the effect is as though the single arch of the previous construction had been divided into two. There is a gap 22 between the arches which can serve the purpose of affording slideways for the platen. The construction is otherwise substantially the same as previously described.

It will be understood that the two forms of press illustrated in the drawings are both up-stroking. If it is desired to build a down-stroking press, this can be done simply by inverting the whole of the illustrated structure so that the base block then becomes the head of the press.

What is claimed is:

1. A press frame comprising a massive, substantially oblong-rectangular section, strip which has side faces of

3

greater width than that of the edges thereof, and which is shaped with a bend about a line parallel to a side face thereof, said line being contained in a plane perpendicular to the planes containing said edges, thereby to form a rigid arch including first and second limbs disposed in parallel relation, the side faces of said strip composing the limbs lying in planes parallel to one another, said arch further including a curved portion of substantially semicircular shape having integral connections with said limbs, a plate member between said limbs and fixed thereto near said connections, a massive strut having one end fixed to said plate member and an end opposite to said one end fixed to the inner side of the center of said curved portion and extending substantially along the length of said curved portion and substantially parallel to and midway between said first and second limbs, and means holding the ends of the limbs remote from said curved portion, in fixed relation.

2. A press frame according to claim 1 and further comprising web plating fixed to and extending between said plate member and the inner side of said curved portion.

3. A press frame according to claim 2 and in which said web plating is fixed to the strut means.

4. A press frame comprising a first massive, substantially oblong-rectangular section, strip which has side faces of greater width than that of the edges thereof, and which is shaped with a bend about a line parallel to a side face thereof, said line being contained in a plane perpendicular to the planes containing said edges, thereby to form a first rigid arch including first and second limbs disposed in parallel relation, the side faces of said first strip composing the limbs lying in planes parallel to one another, said first arch further including a curved portion

4

of substantially semicircular shape having integral connections with said limbs, a second strip of the same form as the first strip and constituting a second rigid arch situated beside said first arch, thereby forming a single composite arch structure, a plate member between the four limbs of said two arches and fixed thereto near said connections, strut means having one end fixed to said plate member and an end opposite to said one end fixed to the inner sides of the centers of said curved portions of the arches and extending substantially along the length of said composite arch structure and substantially parallel to and midway between the first and second limbs of each arch, and means holding those ends of all the limbs remote from the curved portions of the arches, in fixed relation.

5. A press frame according to claim 4 and further comprising web plating fixed to and extending between said plate member and the inner sides of the curved portions of both said arches.

6. A press frame according to claim 5 and in which said web plating is fixed to the strut means.

References Cited in the file of this patent

UNITED STATES PATENTS

43,912	Hittinger	Aug. 23, 1864
367,220	Miller	July 26, 1887
2,150,812	Aukerman	Mar. 14, 1939
2,174,550	Chapman	Oct. 3, 1939
2,932,245	Hausman	Apr. 12, 1960

FOREIGN PATENTS

809,361	Great Britain	Feb. 25, 1959
---------	---------------	---------------