



- (51) International Patent Classification:
H01Q 3/00 (2006.01)
- (21) International Application Number:
PCT/IN2012/000439
- (22) International Filing Date:
20 June 2012 (20.06.2012)
- (25) Filing Language: English
- (26) Publication Language: English
- (30) Priority Data:
3886/CHE/2010 20 June 2011 (20.06.2011) IN
- (72) Inventor; and
- (71) Applicant : MUTHUKUMAR, Prasad [IN/IN]; 20/66,
2nd Street, Dharmanagar, Suramangalam, Salem-5, Tamil
Nadu 636 005 (IN).
- (81) Designated States (unless otherwise indicated, for every
kind of national protection available): AE, AG, AL, AM,
AO, AT, AU, AZ, BA, BB, BG, BH, BR, BW, BY, BZ,
CA, CH, CL, CN, CO, CR, CU, CZ, DE, DK, DM, DO,
DZ, EC, EE, EG, ES, FI, GB, GD, GE, GH, GM, GT, HN,
HR, HU, ID, IL, IN, IS, JP, KE, KG, KM, KN, KP, KR,
KZ, LA, LC, LK, LR, LS, LT, LU, LY, MA, MD, ME,

MG, MK, MN, MW, MX, MY, MZ, NA, NG, NI, NO, NZ,
OM, PE, PG, PH, PL, PT, QA, RO, RS, RU, RW, SC, SD,
SE, SG, SK, SL, SM, ST, SV, SY, TH, TJ, TM, TN, TR,
TT, TZ, UA, UG, US, UZ, VC, VN, ZA, ZM, ZW.

- (84) Designated States (unless otherwise indicated, for every
kind of regional protection available): ARIPO (BW, GH,
GM, KE, LR, LS, MW, MZ, NA, RW, SD, SL, SZ, TZ,
UG, ZM, ZW), Eurasian (AM, AZ, BY, KG, KZ, RU, TJ,
TM), European (AL, AT, BE, BG, CH, CY, CZ, DE, DK,
EE, ES, FI, FR, GB, GR, HR, HU, IE, IS, IT, LT, LU, LV,
MC, MK, MT, NL, NO, PL, PT, RO, RS, SE, SI, SK, SM,
TR), OAPI (BF, BJ, CF, CG, CI, CM, GA, GN, GQ, GW,
ML, MR, NE, SN, TD, TG).

Declarations under Rule 4.17:

— of inventorship (Rule 4.17(iv))

Published:

- with international search report (Art. 21(3))
- before the expiration of the time limit for amending the
claims and to be republished in the event of receipt of
amendments (Rule 48.2(h))

(54) Title: SMART ACTIVE ANTENNA RADIATION PATTERN OPTIMISING SYSTEM FOR MOBILE DEVICES ACHIEVED BY SENSING DEVICE PROXIMITY ENVIRONMENT WITH PROPERTY, POSITION, ORIENTATION, SIGNAL QUALITY AND OPERATING MODES

FIGURE 4
BLOCK DIAGRAM:
Wireless Mobile Device

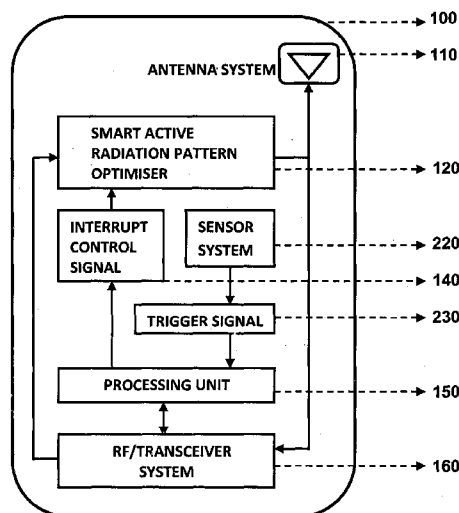

(57) Abstract: The smart dynamic radiation pattern optimising system is a design and technique to actively shape & optimise the radiation pattern of mobile device controlled by smart RF/Antenna system with signal processing algorithm that works by sensing the change in device proximity environment with nature or property, range, orientation, position, location, signal quality parameters and ambient intelligence to protect the user by controlling radiation exposure, enhance RF signal quality and to save battery power. Mobile devices are handled in different proximity environment which influence the antenna performance due to electromagnetic interaction based on environments properties that leads to detuning, radiation pattern distortion, impedance mismatch etc which in turn degrades the signal quality. Also change in device orientation according to usage leads to power loss due to polarization mismatch. So when the signal quality degrades the system will sense & compute in an adaptive closed loop manner to actively optimise the radiation pattern according to scenarios. The design consist of (a) a sensor system 220 to determine the change in proximity environment [close vicinity] with sensing its property, sensing multi - direction, dimension, layer, position & range of proximity environment with respect to device, sensing device (antenna) orientation, visual sensing, infrared or thermal vision, user recognition, user head & hand hold effect, location, usage scenarios & operating modes and accordingly generate the trigger signal 230; (b) a processing unit 150 for computing the interrupt control signal 140 according to the nature of trigger signal & existing signal quality parameters; (c) Smart active radiation pattern optimiser 120 that works based on control signal; (d) Antenna system 110 capable of achieving dynamic radiation pattern coupled with radiation pattern optimiser that actively shapes and controls the radiation pattern accord-

ingly to protect the user and also restores radiation according to scenarios to optimise communication. Other aspects of the present invention are the same sensor system 220 is utilised to develop an application that guides the user locate & position the mobile device in living space to achieve optimised performance, protect the mobile device from theft and ambient intelligence to alert & interact with the user.

WO 2012/176217 A1

SMART ACTIVE ANTENNA RADIATION PATTERN OPTIMISING SYSTEM FOR MOBILE DEVICES ACHIEVED BY SENSING DEVICE PROXIMITY ENVIRONMENT WITH PROPERTY, POSITION, ORIENTATION, SIGNAL QUALITY AND OPERATING MODES

5 **FILED OF INVENTION:**

[001] The present invention is related to mobile communication and particularly to smart active antenna radiation pattern optimising system for wireless mobile device works based on sensing environment, sensor system parameters, signal quality parameters, operating modes and usage scenarios.

10 **BACKGROUND OF THE INVENTION:**

[002] To communicate with the network, mobile phones radiate electromagnetic waves when being used. The antennas in these wireless devices are used for receiving and radiating transmitted signal for communication. Signal quality parameters are not the only one to taken into account in designing the antenna system of mobile device but it is also important to make sure that the user RF exposure levels Specific Absorption Rate (SAR) are within compliance and standards. Mobile devices are handled close against different proximity environments and platforms, depends upon usage scenarios that causes electromagnetic interaction with environments based on its properties which in turn can leads to degradation of signal quality. Also device orientation change according to usage can leads to power loss due to polarization mismatch. In scenarios like when the signal quality is weak the fixed radiation pattern design without sensing the nature of proximity environment and orientation can leads to radiations in directions that are less effective which in turn causes degradation in signal quality. In case of Multiple-Input Multiple-Output [MIMO] antennas arrays the performance is very sensitive to the implementation of the antennas, the environment in which the devices is being used and even the orientation of the device itself. This means that a small change in the position of the device in use can result in significant change in data rate. For example, the user experience of a downloading speed or streaming video etc could go from excellent to marginal or poor just because the device was moved slightly during use. Moreover, the presence of user hand and body cause radiation pattern distortion or detuning of the antennas and absorption of the radiation, thus affecting the efficiency and correlation performance of the antenna array. The constant mobility of the mobile device when in usage further reinforces the need for sustainable performance.

[003] It is not been proved that the generally handled positions of mobile phones to be absolutely safe and is not hazardous. World Health Organization has classified mobile phone radiation as possibly carcinogenic. The World Health Organization (WHO) has also concluded that the precautionary approach is an appropriate response to the lack of scientific consensus regarding the long term health effects of exposure to cell phone radiation. An IEEE journal on Microwave Theory and Techniques shows that the penetration level of radiation is more in children's as the width of skull is less and can also have effect on baby of pregnant women's. The Journal of the American Medical Association by researchers from the National Institutes of Health and the Brookhaven National Lab identifies effect showing through their experiments that holding a cell

phone to the ear increases the metabolic activity of nearby brain tissue. In addition to cancer issue lot of other possible health concerns the radiation can leads to are electromagnetic hypersensitivity, thermal or heating effect, non thermal effect, genotoxic effect, fatigue, loss of memory, cognitive effect, sleep effect, ringing ears, effect on electro-medical devices like pacemaker & hearing aid etc. Several studies
5 investigating the potential health effects of radiation on brain electrical activity, joint pain, heart rate, blood pressure, immune system are under the way. Research conducted regarding health concerns of radiation have increased, papers are published and researches are carried on regarding the long term effects of radiation and its
10 medical complications. Generally these researches will take long time to produce results [advanced clinical report] and by that time the effect caused by the radiation can be substantial like for example smoking causes lung cancer, tobacco usage causes mouth cancer etc are confirmed after many years of study. The mobile phones have become an essential part of many lives not only for communication but also to handle
15 safety and emergency situations. Regulatory Government bodies around the world have adopted international safety guidelines developed by scientific organizations governing the exposure to RF radiation and the mobile phones are designed to operate within these stringent limits. Specific Absorption Rate (SAR) is the measure of amount of radiation or electromagnetic energy absorbed by the body when exposed to radiating
20 devices like mobile phone and has unit of watts per kilogram (W/kg). It's difficult to build an antenna system with more filed strength for better communication and reduced SAR to protect the user from radiation. Most of the radiation shielding products [like stickers, covers etc] available in the market works in standalone mode which is not smart enough or closed loop design to work efficiently according to various scenarios. Some
25 can also hamper the radiated power that leads to negative impact by reducing the signal quality which in turn makes the antenna system to increase the transmitting power level to maintain communication thereby reducing the battery life.

[004] Sensing the change in mobile device proximity environment with its property plays an important role due to electromagnetic interaction with these environments. But
30 currently the antenna system or radiation protection designs are not much concerned about detecting the change in device proximity environment or its property sensing with device orientation to control the radiation pattern which is essential in optimising signal quality as well as protecting the user form radiation. There are some designs to reduce SAR and the main drawback with these designs that uses power regulator, power
35 governing systems etc are it mainly focus on reducing the overall transmit power levels which in turn reduces the signal strength and the possibility of the signal to reach the base station that affects the quality of communication. Proximity environment, orientation, location, position etc of a mobile device are not a constant in real world scenarios and mostly the antenna system tested in lab are just designed to perform
40 optimally which wont helps to efficiently enhancing the performance. It is hard for an antenna system [just with existing signal quality parameters] to act smartly according to scenarios without actively sensing the above mentioned parameters. As the mobile

device proximity environment and orientation changes the fixed radiation pattern also leads to power loss due to radiation in less effective directions.

OBJECTIVE OF THE INVENTION:

5 **[005]** Objective of the invention is to achieve an optimised solution in enhancing RF signal quality, protecting the mobile user by reducing radiation exposure and to save battery power of wireless mobile devices.

STATEMENT OF THE INVENTION:

10 **[006]** The radiation pattern optimising system actively computes and optimise the radiation pattern based on nature of trigger signal from sensor system that sense the close vicinity or proximity environment with property, direction, range, device orientation, location, position, usage scenarios & operating modes there by precisely sensing the effect of proximity environment, direction of proximity environment with respect to device, magnitude of impedance mismatch, radiation pattern distortion levels, user detection, device (antenna) orientation sensing, power loss due to polarization loss factor (PLF), sensing user [body, head & hand hold effects], effect of mobile device platform in addition to existing signal quality parameters in an active, adoptive and closed loop manner. The radiation pattern is optimised through controlling gain & directivity, adaptive beam forming, shaping, switching, steering, spatial processing & filtering, adoptive antenna system to match polarisation, controlling transmit power levels etc according to scenarios. Ultimately the present system enhance the ambient intelligence of the mobile device to more precisely sense and feel the human presence and other proximity environment thereby to act according to scenarios. The sensor systems precision levels, sensing depth of dimension and multi layer sensing are utilised depends upon the design & requirement.

25 **SUMMARY OF THE INVENTION:**

[007] To address the issues with other designs and to enhance the signal quality with reduced SAR, the present invention provides a smart active dynamic radiation pattern approach that works mainly based on sensing the change in device proximity environment with its property, position and device orientation to actively shape & optimise the antenna radiation pattern, match polarisation, control transmit power levels, controls gain & directivity, resonant frequency etc utilising active, smart and adaptive closed loop antenna system with signal processing algorithm is presented. The main advantage of the present invention is that the system predominantly utilises the already existing components of the mobile device with little more sophistication and coding thereby making implementation easy and substantially reducing the implementation cost. The system works in conjunction with existing communication system standards, architecture, radio access techniques, signal quality parameters and specifications there by support the mobile device to efficiently enhance its performance [E.g. mobile communication, Wi-Fi, WiMax, Bluetooth, Zigbee etc]. It is practically difficult to make sure that the user handles the mobile devices in an optimised position to achieve best performance as user might not be aware of or always technically sound to understand the issue behind it. So the present invention provides a solution that can act smartly according to scenarios. The antennas are not smart by itself but it is the

antenna systems that makes it to work smartly. In case of mobile antenna system design, it is important to take SAR into account while designing signal quality enhancement system. So generally user head & hand hold effects, SAR etc are taken into account. But with the property sensing capability of the present invention the system can more precisely sense the user & other proximity environment [in addition to usage scenarios] with their effects on radiation pattern, its direction and position with respect to device (antenna) in real time usage scenarios to achieve an optimised solution in user protection and enhancing signal quality. Instead of reducing the overall radiated power with other designs to reduce SAR the present invention primarily focus on multi mode dynamic radiation pattern and multi directional antenna amplification for actively shaping, controlling and reducing the intensity of radiation on direction facing the user or affecting proximity environments and accordingly maintaining the radiation on other directions taking existing signal quality parameters into account to sustain quality of communication. In scenarios like when the signal quality is weak or drops below threshold the present invention provides more flexibility than other designs by sensing and improving signal quality as well as protecting user by maintaining the radiations on user facing directions according to SAR compliance and standards while altering the intensity on other direction to sustain communication. The protection system not only controls the radiation on user facing direction to reduce SAR [E.g. During direct phone call conversation] but also actively restores radiation according to parameters, scenarios and configuration to optimise communication [E.g. speaker mode, head set or hands free, download or data transfer mode etc]. Also the system helps to enhance DOA processing and computing beam forming vector. The sensor system scans frequently or based on configurations and usage scenarios. By shaping or focussing the radiation in right direction, power and time the system can also saves battery power. The present invention utilises either one or combination of following aspects to enhance the precision of the system there by to optimise the radiation pattern.

[008] According to one aspect of present invention the proximity, range and orientation sensors sense the change in proximity environment [or platform] of wireless mobile device with its property, sensing environments direction, range, multi layers and position with respect to device, sensing user [head, body & hand hold effects] and device orientation to accordingly shape and optimise the radiation pattern. The sensor system senses the change in proximity environment with its property, position, direction, device orientation etc and triggers the processing unit. The processing unit compute the control signal based on trigger from sensor system, effect of proximity environment on antenna [antenna degradation], magnitude of radiation pattern distortion, impedance, user protection and signal quality parameters to determine how the radiation pattern has to be shaped and optimised with corresponding transmit power levels. Based on the control signal the radiation pattern optimiser will direct the RF/antenna system to actively control and optimise the radiation pattern thereby to protect the user as well as to enhance signal quality.

[009] According to another aspect of present invention one or more sensors or cameras either visual or infrared [thermo graphic] or combination of both and range sensors are

optimally placed in the device [or around the device] according to design for sensing the proximity environment, detecting human presence, face & body recognition, computing distance or range of user & proximity environment thereby to shape the radiation pattern for protecting the user from radiation exposure and to optimise signal quality.

5 The cameras and range sensors are optimally located in the mobile device to scan for the user and environment in omni direction, sensing multi dimension, direction & distance of user & proximity environment. The system also utilise already existing front & rear cameras, side cameras and helps to protect the user in scenarios like video call, browsing, downloading, watching mobile, games etc.

10 **[010]** According to another aspect of the present invention to further enhance the efficiency of the system orientation sensors like gyro sensor, accelerometer, E-compass or magnetometer, inclinometer and similar sensors [multi axis sensors] are utilised to actively sense the change in device [antenna] orientation and accordingly optimise the smart reconfigurable RF/antenna system that can change & adopt to actively match
15 polarization of communicating devices [with the knowledge of relative antenna orientation] to enhance the signal quality. The change in orientation of the mobile device [antenna] is hard to reliably predict and the system utilise polarisation matching algorithm that helps to actively sense & mitigate the power loss due to polarization mismatch and thus controls the polarization loss factor [PLF]. The orientation sensor
20 actively senses the change in device orientation and triggers the processing unit. The processing unit computes the control signal based on trigger signal, relative antenna orientation of communicating devices, oblique instincts, threshold levels and other signal quality parameters to determine the nature of orientation or excitation phase to be adopted. Based on the control signal, the system will optimise the reconfigurable
25 antenna system to match the polarization thereby to enhancing the signal quality. The antenna system is directed to actively match or optimise to either one common or reference polarization [predetermined one] else based on the actively shared information to optimise polarization between communicating devices accordingly.

[011] According to another aspect of present invention the trigger signal is based on
30 usage scenarios or operating modes like direct & video call modes, speaker mode, hands free or headset modes, belt pouch & clip detection, key pad & touch screen detection, Wi-Fi & Bluetooth mode, sensing wireless modem & data transfer modes, game & browsing modes, cradle or holder detection, standby mode etc. The processing unit will analyse the corresponding trigger signal from either one or
35 combination of multiple components with signal quality parameters to determine the nature of the control signal to radiation pattern optimiser. The radiation pattern optimiser will direct the RF/antenna system to optimise the radiation pattern accordingly.

[012] According to another aspect of present invention the processing unit depends upon the communication system design, scenarios and acting modes of the devices
40 actively shares information & parameters between the communicating devices and utilise either one or more parameters like devices proximity environment with property, device orientations [antenna orientation], location, position, altitude, existing signal

quality parameters etc to shape and optimise the radiation pattern between them accordingly.

5 **[013]** According to another aspect of the present invention the system utilise correlation tables or field mapping tables or threshold level tables or lookup tables which are the comparison tables to actively check and compares the effects between predetermined and tested real world scenarios to the actual real world scenarios with which the system actively optimise the antenna radiation pattern. Parameters like proximity environment with property sensing, effect of proximity environment on antennas, impedance, return loss or SWR, radiation pattern distortion, range, near and far fields, various location & position, orientation, excitation phase, direction, various usage scenarios, operating modes, sensing user [head, body and hand hold effect of user] and signal quality parameters are all taken into account and utilised depends upon design & scenarios for the computing the predetermined and tested mapping tables. These tables helps to determine the change in proximity environment with its property, direction, position, range, user sensing, relative antenna orientation of communicating device and effect caused by it more precisely so that the system can shape or optimise the radiation pattern efficiently.

15 **[014]** According to another aspect of the present invention the antenna system [E.g. antenna arrays or MIMO antenna] itself act as sensors in sensing the change in proximity environment with its nature based on change in antenna impedance, return loss or SWR & gain [across various antenna like arrays], environments position & range with respect to device there by shaping and optimising the radiation pattern according to predetermined and tested field mapping tables. The system senses the effect of proximity environment and its direction with respect to device (antenna). The processing unit sense the antenna system parameters like change in input impedance [magnitude of impedance mismatch], return loss or SWR, gain, signal quality, antenna detuning, channel capacity [across various antennas], effect of user [head body, head and hand hold effects] and compute with the predetermined & tested table to shape and optimise the radiation pattern.

25 **[015]** According to another aspect of present invention an application software is developed utilising sensor system parameters, signal quality parameters, channel capacity, usage scenarios & operating modes that guides the user to more precisely select the optimum location and position for using the mobile device in user living space thereby to achieving best signal quality and to saving battery power. The processing unit actively compute to guide the user based on sensor system parameters, signal quality parameters and operating modes or usage scenarios to determine the optimum location.

35 **[016]** According to another aspect of the present invention the same sensor system like visual, infrared or thermo graphic cameras and sensors are utilised to alert the user regarding the unattended incoming calls, mails, message, alarm etc by automatically sensing the user presence even in zero light environment. The system utilise one or more optimally located cameras and sensor to scan for the user in multi direction

irrespective of presence of light or pitch environment dark and alerts the user when the user brought himself within the range of sensor system.

5 [017] According to another aspect of present invention the proximity sensors, magnetometer or compass with location & positioning system [E.g. GPS] are utilised to alert the user regarding the unattended missed calls, messages, mails etc. When the user needs to be alerted regarding missed call, mail etc the system sense the current sensor system parameters & [or] starts monitoring the change in sensor system parameters. When the user take the mobile device which ultimately leads to change in sensor system parameter like proximity environment, compass readings and location
10 which are utilised by the system for alerting the user through voice message, display, ring tone etc.

[018] According to another aspect of the present invention the system utilise temperature, moisture, humidity sensors to senses the environment of mobile device like extreme temperatures [hot or cold], moisture or humidity that can affect the
15 electronic components of mobile device thereby alerting the user to protect the mobile device. The alerting can selected from ringing, vibrating, alert message on display, SMS, call, voice message etc.

[019] In yet another aspect of present invention a smart active mobile device protection & tracking system is developed utilising the sensor system to sense the unauthorised
20 access to mobile device thereby alerting the mobile user to protect the device. The present invention works utilising combination of sensor system and application to smartly protect the mobile device from theft. Generally access to the mobile device leads to change in sensor system parameters like device proximity environment, orientation etc and the enabled system monitors for change in parameters to alert the
25 user. When a device is disturbed by or through unauthorised access the system will sense the change in sensor system parameters and immediately expects & awaits for authentication. If authenticated successfully as per pre configured settings the system won't alert but if not authenticated the system will alert the user by ringing, vibrating, illuminating, active location tracking etc. Also the activated system acts according to
30 incoming call, SMS, mails etc depends upon the configuration.

BRIEF DESCRIPTION OF THE DIAGRAM:

[020] To get a comprehensive understanding of the system, diagrams are described by examples.

35 FIG. 1 illustrates components of the system - radiations from mobile device widely in all directions with base station and dotted lines representing the controlled reduced radiation on user facing direction

FIG. 2 illustrates various mobile device handling position models. The front and top view of mobile device radiation incident on user head and the dotted lines representing the controlled radiation on direction facing the user head while maintaining the radiation
40 on other directions

FIG. 3 illustrates mobile device on various usage positions, proximity environment or platforms and device orientations.

FIG. 4 illustrate the block diagram of portable wireless device with components of smart radiation pattern optimising system according to the present invention.

FIG. 5 illustrates the flowchart and describes the method of operation of the smart radiation pattern optimising system.

5 FIG. 6 illustrates proximity sensor system sensing the user and proximity environment with nature.

FIG. 7 illustrates the mobile device with models of 2x2 and 4x4 antenna arrays with proximity and orientation sensors.

FIG. 8 illustrates the models of potential communication systems to utilise the system like Wi-Fi and Bluetooth with various modes.

DETAILED DESCRIPTION:

10 **[021]** The main aim of smart radiation pattern optimising system is to achieve an optimised solution in balancing between enhancing signal quality and simultaneously reducing SAR. When the signal quality degrades or reaches below the threshold level the system monitors, computes and shape the radiation pattern accordingly in real time to achieve the best signal quality. As multiple parameters are taken into account for
15 optimising the radiation pattern, the system to make sure that the optimising is done by taking one or more parameters according to scenarios, communication system design and acting modes with ultimately prioritising & optimising between to the protect user by reducing radiation exposure levels, achieving best signal quality and to save battery power. Also as the system utilise multiple sensors & parameters the system smartly
20 coordinate between the various sensors according to scenarios & usage or operating modes to optimise the performance and to save battery power. In case if the parameters need to be obtained is out of scope of one sensor, the system smartly & actively switch between multiple feasible sensors and other associated sensors to continue with tracking and obtaining of parameters for further processing. The sensor
25 system smartly turns off the out of scope sensors accordingly to save the battery power. For example when the user place the mobile device upside on a platform the system utilise front camera for sensing environment and if upside down automatically utilise rear side camera in addition to other associated sensors like proximity sensors, orientation sensors, ambient light sensor etc to enhance the precision of the system.
30 The smart radiation pattern optimising system also utilise artificial intelligence & neural network for sensing & learning the usage scenarios [routine usage] thereby to act accordingly. When multiple proximity things are around the device, the system checks for appropriate space & proximity environment based on its property, device orientation, location, position, range, channel capacity and signal quality parameters for selecting
35 the best feasible directions to actively shape and optimise the radiation pattern.

[022] FIG. 1 illustrates the components of the wireless network according to the present invention consisting of Mobile device **100**, User **170**, Base station **190** and the radiation **180**. To communicate with the network wireless mobile device **100** radiate electromagnetic waves that are received by the base station **190** to connect with the
40 backbone network. During this communication the antenna of the mobile device **100**

radiates power widely in all direction. This leads to portion of radiation **180** facing the user **170** to be absorbed by user body which leads to lot of medical complications. The system controls the intensity of radiation **180** [dotted lines] facing the user **170** to reduce SAR while accordingly maintaining the radiation on other directions to sustain quality of communication. The system not only controls the radiation on user facing direction while correspondingly maintaining the radiation on other directions but also restores radiation on user facing direction according to operating modes, usage scenarios & signal quality parameters to enhance communication.

[023] FIG. 2 illustrates various models of mobile device direct call conversation positions & usage. As the mobile handling position and device orientation changes according to usage scenarios the system sense the change in proximity environment with nature, positions and device orientations there by to accordingly vary the radiation pattern [align the controlling of radiation pattern] to sustain quality of communication and reduce SAR. Also the last two figures illustrates the radiation incident on user head **175** from wireless mobile device **100** with front and top view diagrams and the dotted lines representing the controlled and reduced radiation **180** on direction facing head as per the present invention while maintaining the radiations on other directions.

[024] FIG. 3 illustrates mobile device on various positions, proximity environments or platforms and different orientation that changes according to usage. The system senses the device proximity environment and orientation to optimise the radiation accordingly.

[025] FIG. 4 is a block diagram describing the working principle of smart antenna radiation pattern optimising system. Actually lot of components are there in mobile device **100** and the block diagram gives a brief description about various integral components according to present invention like antenna system **110**, smart active radiation pattern optimiser **120**, sensor system **220**, trigger signal **230**, interrupt control signal **140**, processor **150**, RF/transceiver system **160** etc. In general mobile cell phones consist of processor that controls the overall functions of the device. The processor handles lot of operations and the disclosed invention primarily focused on processor **150** interacting with sensor system **220**, trigger signal **230**, interrupt control signal **140**, RF/transceiver system **160**, smart radiation pattern optimiser **120** etc. The processing unit manipulate the control signal to actively optimise the radiation pattern based on trigger signal from sensor system **220**, signal quality parameters [like gain, RSSI or ASU, antenna sensitivity, SNIR, antenna impedance, TIS/TRP, PLF etc], sensing user head & hand hold effects, transmit power levels, channel capacity, operating mode or usage scenarios. Sensor system **220** is a combination of various sensors like proximity sensors, orientation sensors, direction, location & position sensors, distance or range sensors, visual or infrared sensors, temperature sensor, humidity or moisture sensor etc and also the system acquire information from other components to monitor the usage scenarios or operating modes of mobile device for generating trigger signal **230**. As the system works with critical mobile functions like signal quality enhancement, user protection and saving battery power a high priority interrupt can be assigned for manipulating the control signal **140** if a general mobile processor is used. In another aspect of the present invention a dedicated RF

processing unit can be used for the manipulation of control signal **140** to smart radiation pattern optimizer **120** or in yet another aspect the radiation pattern optimiser **120** itself can be used for the manipulation of the control signal **140** by taking corresponding parameters into account.

5 **[026]** According to one aspect of the present invention the proximity, range and orientation sensors of sensor system **220** determines the change in wireless device **100** proximity environment with its property, direction, range, device orientation etc and will send the corresponding trigger signal **230** to the processor **150**. The processor **150** initiate interrupt service routine based on trigger signal from sensor system **220**. The
10 nature of trigger signal **230**, transceiver **160** signal quality parameters, user radiation protection parameters are taken into account by the processor **150** to compute the interrupt control signal **140** to smart radiation pattern optimiser **120**. Based on the interrupt control signal **140** the smart radiation pattern optimiser **120** actively shape & optimise the radiation pattern utilising corresponding RF/antenna system **110** to protect
15 the user **170** & enhance signal quality. One or more proximity and range sensors [or sensor arrays] are optimally positioned around the device for precisely sensing the human presence and other proximity environment in multi direction, position and orientation with respect to mobile device. The sensor system senses the change in device proximity environment with its property [or nature], sensing proximity [or vicinity]
20 environments - direction, dimension, multilayer, range or distance & position with respect to device, simultaneously sensing multiple proximity environments surrounding the device, user recognition [head body & hand hold effect], MSP [Mobile sensing Platform], ambient intelligence are utilised by processing unit for further processing. The radiation pattern gets significantly affected when the affecting proximity environment is
25 within certain range of mobile device due to electromagnetic interaction based on environments property. So the system actively checks for any proximity environment within the range or boundary that can significantly affect the antenna performance [like antenna detuning, degradation, distortion, impedance, fading, absorption, reflection etc] thereby sensing the change in proximity environment with property, position, direction &
30 range with respect to device, magnitude of antenna degradation, signal quality parameters etc to shape the radiation pattern accordingly. The multi layer with property sensing capability helps the system to more precisely senses beyond the user dress material [cloths] like device placed inside shirt pocket, pant pocket, sensing head, body, in hand, belt pouch, stand, over a platform etc to actively protect the user as well as
35 optimising signal quality in scenarios like on call or hands free or headset mode, prolonged download, streaming etc. The sensor system utilised are [e.g. proximity or contact sensor] capable of scanning & sensing the property of proximity environment E.g. permittivity- ϵ , permeability- μ , conductivity- σ , susceptibility, dielectric constants, capacitive sensing, capacitive displacement sensing etc. For example the sensor
40 system like capacitive proximity sensor works by generating the electric field and measuring the attenuations suffered by the field there by detecting the proximity environment with its property. Since the measurement of attenuation or distortion suffered by the EM waves from antenna can differ from that of the field created by

sensor system a predetermined and tested field mapping table [with threshold levels] between sensor system and antenna radiation are utilised for sensing, comparing & matching the nature and effect caused by the proximity environment for further computation. Even one or more sensors are utilised to precisely sense proximity environment and user device proximity with head, body and hand hold effects that are taken into account for computing the trigger signal. Also when the device is not in proximity to the user in scenarios like speaker mode, data transfer or access internet modem, the system will dynamically change its radiation pattern accordingly to improve the data transfer rates and quality of communication. The system not only helps to enhance DOA processing but also helps to compute beam forming vector and optimise radiation pattern to enhance signal quality.

[027] According to another aspect of present invention the sensor system **220** utilise one or more sensors or cameras either visual or infrared [thermo graphic] or combination of both and range sensors that are optimally located in the device according to design for sensing the environment, detecting human presence, face & body recognition, iris recognition, computing range or distance of user & proximity environment to shape the radiation pattern accordingly for protecting the user from radiation exposure and to optimise signal quality. The cameras and range sensors scans for users and environment in 360 degree, multi direction, dimension and sensing the range or distance of user or proximity environment with respect to device. The system also coordinates with other sensors like proximity sensors, orientation sensors etc and also utilise active Digital Signal & Image Processing [DSP & DIP] techniques to enhance the precision of the system [E.g. Signal processing techniques not only helps to recognise human presence but also helps to sense the magnification of face to detect the range etc]. In scenarios like [prolonged] phone call, speaker mode, video call, browsing, games, downloading, streaming etc the user might hold the device [in front] and the system checks for the user within the range where the radiation can significantly affect the user. Once the system detects the user it looks for range of the user, as the range of the user presence is crucial for protecting the user as well as computing the magnitude of radiation pattern distortion etc to shape the radiation pattern accordingly. The system accordingly shape and optimise the radiation pattern by also accounting presence of multiple user with their range, signal quality parameters and battery power consumption. The system utilises omni directional cameras, 360 degree sensors or cameras [visual & IR], popup cameras, front & rear cameras, side cameras, 3D cameras and the lenses utilised are ordinary camera lens, super or ultra wide angle lens, fisheye lenses, extreme angle broadband metamaterial lenses, tuneable metamaterial lenses, super lenses etc. The cameras, sensors, lens, aperture etc are all selected according to design and requirement ultimately for scanning and detecting the environment in multi direction [all possible direction]. The present ambient intelligence system utilising sensors and cameras that works on sensing human presence irrespective of whether the mobile device is kept in light or pitch dark [zero light] environment as thermal vision [night vision] works in absolute darkness, fog, rain, smoke etc. The system senses the user presence when the user brought himself within

the range of sensors or cameras (E.g video call, browsing, downloading, chatting, games etc)]. Already most of the current generation mobile devices have both front and rear cameras and the system utilise these already existing cameras. The sensors or cameras, lenses, aperture, wide angels etc and other related parameters are selected according to designed and requirement. The sensor system **220** senses the environment and generates the trigger signal **230** to the processing unit **150**. The processing unit **150** computes the interrupt control signal **220** by sensing the user presence & other proximity environment with its range and signal quality parameters. The radiation pattern optimiser **120** shape and optimise the radiation pattern accordingly with smart antenna system **110**. One or more distance or range sensors and cameras are selected from ultrasonic range sensor, infrared range sensor, acoustic range sensor, visual range sensor, photo electric range sensor etc and are utilised by the system. The system computes the direction, dimension and range of the user with diffraction [diffraction limits] to shape the radiation pattern accordingly to protect the user as well as to sustain signal quality. Also the system can also turn off the out of scope cameras [E.g. based on nature of trigger signal from proximity sensor, ambient light sensors etc] to save battery power.

[028] According to another aspect of the present invention to further enhance the efficiency of the system in addition to other sensors the sensor system **220** utilises gyro sensor, accelerometer, E-compass or magnetometer etc and similar sensor to actively sense the change in orientation of the wireless mobile device **100** and accordingly reconfigure antenna to actively match the polarisation to enhance the signal quality. The orientation of the mobile device **100** changes depends on usage scenarios for example during data transfer or call conversation mode the user might use the device in different orientation angles and positions like while standing, sitting on a chair, laying on a bed etc, which leads to change orientation of device. So controlling the polarisation should also align according to change in antenna orientation of corresponding communicating device to efficiently match polarisation. The system works by sensing the change in device [antenna] orientation and actively controlling or reconfiguring antenna orientations, excitation phase, varying the dual polarization ratios etc with smart antenna system to match the polarisation of corresponding communicating devices thereby to actively sense, optimise and mitigate the power loss due to polarization mismatch. Another issue the Mean Effective Gain [MEG] is always treated as single, fixed number which is only valid for certain fixed orientations of antenna with respect to the direction of the multipath components in the propagation channel. This explains reason why moving the mobile phone on your head to a different angle can sometimes increase reception. Mobile device antennas are often linearly polarized, so rotating the device can often match the polarization of the phone and thus increase reception. But in practical situations the orientation of the handset [and thus its antenna] cannot be reliably predicted. Moreover channel properties such as cross-polarization ratio and the angular spread are stochastic variables in nature. The sensor system sense & compute with device orientation, lookup table, oblique instincts, signal quality parameters, channel capacity and accordingly reconfigures the corresponding antenna

system [E.g. switching or reconfigurable antennas, control excitation phase etc] to optimise radiation pattern with subsequent polarization in real time thereby matching polarisation of communicating devices to control the Polarization Loss Factor (PLF). Based on the trigger signal **230** from orientation sensors **220** and signal quality parameters from transceiver **160** the processing unit **150** compute the nature of control signal **140** to radiation pattern optimiser **120**. The radiation pattern optimiser **120** controls the reconfigurable antennas systems orientation or excitation phase according to the control signal **140** thereby to match polarisation and enhance the signal quality. The antenna system of the communicating devices works by either sensing the change in device [antenna] orientation or based on actively shared information between communicating devices regarding its own orientation else optimising to one common or reference polarization [predetermined one] to match polarisation between communicating devices. Orientation threshold levels are utilised to vary & reconfigure the antenna orientation or excitation phase and the levels are fine tuned according to design and requirement.

[029] According to another aspect of the present invention the sensor system **220** determines the change in operating mode or usage scenarios of mobile device by sensing either one or more parameters comprise of direct phone call mode, speaker mode, hands free, headset detection, video call mode, bluetooth mode, belt pouch or clip sensor, key pad or touch screen detection, internet access or download mode, Wi-Fi mode, sensing wireless modem mode or data transfer mode, standby mode, cradle or holder sensor etc and generate the trigger signal **230**. The processor **150** computes the control signal **140** to smart radiation pattern optimiser **120** based on signal from either one or combination of multiple sensors, usage scenarios and operating modes simultaneously accounting signal quality parameters from transceiver **160**. Based on the interrupt control signal **140** the radiation pattern optimiser **120** will control the RF/antenna systems **110** to vary radiation pattern accordingly to enhance signal quality. The system protects the user from radiation in some scenarios where trigger signal can be based on just sensing one or more parameters for example in direct call mode mostly the user use the mobile device proximity to head which is taken as a parameter to control the radiations on user facing direction [the system also utilise sensor system parameters to further enhance the performance].

[030] According to another aspect of present invention the processing unit depends upon the communication system and corresponding acting modes of the devices, actively shares information or parameters between the communicating devices regarding devices like proximity environment with property, device [antenna] orientations, location, position, altitude, channel capacity, signal quality parameters etc and the devices antenna system utilise either one or more parameters to shape and optimise the radiation pattern between them accordingly. The sensor system **220** generates trigger signal to processing unit **150**. The processing unit **150** computes the control signal **140** to smart radiation pattern optimiser **120** based on either one or combination of predetermined or actively shared information simultaneously accounting signal quality parameters from transceiver **160**. Based on the interrupt control signal

140 the radiation pattern optimiser 120 will control the RF/antenna systems 110 to optimise the radiation pattern accordingly. The communication system can either work in master/slave architecture or Peer to peer [E.g. WIFI direct] or adhoc or mesh network etc. For a mobile device operating in real world scenarios it is difficult to predict the feasibility of LOS [Line of Sight] and non LOS. There are scenarios where line of sight [LOS] between communicating devices is feasible in a living space, open ground etc and there are scenarios where LOS is affected by the environments like walls etc. However, mostly the time the main directions of arrival do not change rapidly. Nowadays most of the mobile devices are equipped with location & positioning systems [E.g. GPS, AGPS etc] which helps the devices to know its own location. The system verify the feasibility to enhance signal quality utilising actively shared information regarding location & position of the communicating devices to check for the direction with respect to each other, thereby actively shaping and optimising the radiation pattern & transmit power levels between devices. For example in case of mobile communication the base station [BTS] or access points can be pre provisioned to advertise or share the parameters like its exact location [E.g. GPS] and antenna orientation information [which are mostly fixed] with the connecting mobile devices [which already know its own location and antenna orientation with inbuilt GPS and orientation sensors] that helps to shape & optimise the radiation pattern accordingly to enhance signal quality and to save battery power. As the BTS or access points antenna orientation is mostly fixed, all the mobile devices tends to match the polarization of BTS or access point [a master slave architecture can be utilised where BTS or access point act as master and all mobile device act as slave]. These implemented can be performed with least cost and complication as this is a onetime configuration during installation of base station and performed based on location information form GPS, antenna orientation etc. In case of one to one communication [E.g. WiFi direct, Bluetooth data transfer] either one or both the device optimise the radiation pattern between each other and in case of multiple devices exist in communication systems [E.g. WiFi infrastructure (Access point) or adhoc, mesh network] the entire communicating devices actively shares the related information between each other and optimise radiation pattern with smart antenna system [E.g. optimise radiation pattern according to access point].

[031] According to another aspect of the present invention the system utilise correlation tables or field mapping tables or threshold level tables or lookup tables which are comparison tables to actively check and compares the effects between predetermined and tested real world scenarios to the actual real world scenarios with which the system optimise the antenna radiation pattern. The design and the values in the tables are processed and developed based on parameters like proximity environment with property sensing, effect, direction & range of proximity environment, input impedance, return loss or SWR, gain, orientation, oblique instincts, location & position, effect on near & far fields, RSSI or ASU, transmit power levels and other signal quality parameters are all tested at various frequencies & scenarios that are taken into account and utilised depends upon design and operating modes. These helps the system to

determine the change in proximity environment with its property, direction & range, user sensing [head, body and hand hold effects], dielectric values [band of user body and other proximity environments], conductive & dielectric nature, magnitude of radiation pattern distortion, proximity environments location, position & direction, antenna orientation, magnitude of impedance mismatch with effect caused more precisely so that the system can actively adapt by shaping and optimising the radiation pattern efficiently. The sensor system **220** sense and generates trigger signal **230** to the processing unit **150**. The processing unit **150** computes the control signal **140** to smart radiation pattern optimiser **120** based on the parameters collected & compared with field mapping tables or threshold level tables simultaneously accounting signal quality parameters from transceiver **160** to precisely sense the effects to optimise the radiation pattern accordingly. Based on the interrupt control signal **140** the radiation pattern optimiser **120** will control the RF/antenna systems **110** to optimise the radiation pattern accordingly. The resolutions of the tables are fine tuned according to design and requirement.

[032] According to another aspect of the present invention the antenna system [antenna arrays or MIMO antenna] used for communication itself act as sensors in sensing the proximity environment based on change in antenna impedance, gain, SWR or return loss etc [across the arrays] there by actively shaping and optimising the radiation pattern according to compared results with predetermined and tested lookup table designed and developed [taking parameters like impedance, gain, SWR, RSSI, channel capacity etc] with various real world scenarios and frequencies. As the proximity environment based on its property affects the antenna impedance, the nature & magnitude of change in impedance levels, gain, SWR are all utilised for sensing the effect of proximity environment and its direction with respect to device (antenna). Also as the channel capacity, signal strength and quality vary between multiple antennas [E.g. antenna arrays] the system actively sense and optimise the radiation pattern between multiple antennas accordingly [multi directional antenna amplification]. The processing unit **150** senses the change in input impedance, gain, SWR, channel capacity, RSSI [across antennas] and compare with the predetermined and tested lookup table to compute the control signal **140** to smart radiation pattern controller **120**. The radiation pattern controller **120** controls the antenna system **110** to actively optimise the radiation pattern. The system works in an active, adoptive and closed loop manner from sensing, monitoring, comparing, computing and optimising radiation pattern to achieve best performance.

[033] According to another aspect of present invention an application software is developed utilising sensor system **220** parameters, signal quality parameters, usage scenarios and operating modes of the device that guides the user to select the feasible & optimum - location and position for using the mobile device in the user living space there by helping in achieving best signal quality and saving battery power [E.g. during a long time call conversation, Bluetooth & Wi-Fi mode, internet access, prolonged downloading, games, wireless modem mode, multimedia streaming etc]. The mobile device maximise the transmitting power or radiate more power when the signal quality

is weak [in some locations] to maintain communication which significantly reduces the battery power. The present application actively helps in guiding the user with more precise and enhanced information to locate the mobile device in optimum location and position to achieve maximum signal quality [that even enhance the data rates] and can
5 utilise wireless headset [Bluetooth] for conversation. The system works by sensing the effect of device proximity environments, device orientation, signal quality parameters, usage scenarios, operating modes and battery power. The system can also alert the user regarding low signal quality and high EMI [Electro Magnetic Interference]. The application sense the transmitted power level and alerts the user to locate the mobile
10 device in optimum location and position so that the user can utilise wireless hands free, headset or speaker mode for further conversation. The processing unit **150** actively compute the sensor system **220** parameters [trigger signal **230**], usage scenarios, operating modes and signal quality parameters to compute & guide the user regarding optimum location for using the mobile device.

[034] According to another aspect of the present invention the same sensors sensor system **220** like visual, infrared or thermo graphic cameras and sensors are utilised to alert the user regarding unattended parameters like missed calls, mails, message etc by automatically sensing the user presence when the user is back. There are scenarios where time is a very important factor. E.g. when the mobile device alerts the user
20 regarding calls, messages, mails, schedule task, memo, meeting, to do note etc and if the user is not available generally the application will stop alerting in a particular time [may only alert after some time according snooze time settings, second alarm timings & other settings etc (which works irrespective of user presence)], where in these scenarios the users are made to wait till the next alert or some times without alert that
25 can leads to loss of users valuable time. So even when the user is available or within the scope of the device, the device won't alert the user regarding the unattended parameters. The present system smart remainder generally alert as per the incoming calls, mail message etc, but in case if not attended the system won't wait till the user pickup the mobile device to check and will immediately alert the user by sensing the
30 user presence automatically when the user is back. The system senses the user when the user brought him within the scope or range of sensors & cameras [E.g. entering the room, back & working near mobile device etc]. The alerting can be selected and performed through display, ring tone, vibrating, voice alert etc. The present ambient intelligence system utilising sensors and cameras that works by sensing user presence,
35 face recognition, iris recognition to alert the user, irrespective of whether the mobile device is kept in light or pitch dark [zero light] environment. Whenever the user needs to be alerted [regarding E.g. Missed call, mails etc] the system automatically turns on the sensors [according to predetermined or user configured settings] to monitors the user presence and when detects the user the system starts alerting immediately and can
40 interact with the user to convey further information [E.g. voice message etc]. Even the system can be enhanced with face & iris recognition to alert actual mobile user [when available] in scenarios where multiple people exist in the environment. MIC and ambient light sensors are utilised to enhance the precision of the system in sensing the

environment. The system also helps the searching user to easily locate the mobile device with voice command [code words] that works even in a dark environment instead of turning on the lights and to find the out of sight device. Voice commands can be utilised by the user to check for missed parameters & search the mobile device which is sensed by the MIC that makes the mobile device to advertise its availability through reply voice message, ring tone, display, vibrating etc. Already most of the current generation mobile devices have both front and rear cameras and the system utilise one or more of these cameras and other cameras. The optimally located cameras, sensors and its lens, aperture etc are all selected according to design and requirement ultimately for scanning user in all possible direction [multiple direction simultaneously] to detect the user. The system automatically initiates itself [sensor system **220**] when the user need to be alerted regarding missed parameters. The sensor system **220** senses the environment and generates the trigger signal **230**. The processing unit **150** process the trigger signal information to check for user presence and will alert the user accordingly. When alerting the system can be controlled by the user through voice command without taking the mobile device to check for information regarding unattended missed call, message, mails and can control the phone functions like making a phone call, message through voice command. The mobile device interacts with the user through voice, display or both. Also the system can interoperate with other ambient intelligent systems like home & office ambient intelligent system, wired & wireless networks [E.g. Wi-Fi, DLNA] etc to alert the user in right place regarding the unattended parameters E.g. user might place the mobile device in one room and available in different room. The home and office ambient intelligent system sense the user presence and alerts [through lights, voice message, ring tone etc] in the place where the user is available so that the users are made aware to take further action. In case of wireless network the user is alerted through audio and video systems [when watching movies, listening to music, meeting, working in gym etc] by sensing the user [even actual user with face and iris recognition] to sense the availability of the user. The system can also turn off the out of scope cameras & associated sensors based on nature of trigger signal from proximity sensor to save battery power. The use of the present system is not limited to above aspect but can also be enhanced to other potential applications not listed here provided the scenarios are within the scope of the present invention.

[035] According to another aspect of present invention the proximity sensors, magnetometer and location or positioning system [E.g. GPS] etc are utilised to sense the change in device proximity environment, direction & location to alert the user regarding the unattended parameters like missed calls, messages, mails etc through voice alert or message, display and ring tone. When the user needs to be alerted regarding missed call, mail etc the system sense the current sensor system status and [or] monitors for the change in sensor system parameters. When the user take the mobile device which ultimately leads to change in device proximity environment, direction & location which are utilised by the system to sense and alert the user. When an unattended calls, messages, mails etc are sensed by the system, the sensor system

220 is turned on to monitor for any change in parameters like change in device proximity environment, direction and location. When the change in parameters is sensed the system generates the trigger signal **230** processing unit **150**. The processing unit **150** alert the user regarding unattended parameters through display, ring tone, voice alert etc.

[**036**] According to another aspect of the present invention the sensor system **220** utilise temperature, moisture & humidity sensors to senses the environment of mobile device like extreme temperature, moisture or humidity thereby to alert the user for protecting the mobile device. Mobile device generally consist of lot of valuable information's [E.g. contacts, files, photos etc] stored in it and the system not only helps to protect the mobile device but also saves the valuable information's. The components in the mobile device are sensitive and designed to operate in range of temperature, moisture etc [upper cut-off and lower cut-off threshold levels]. Exceeding these threshold levels and prolonged exposure to these environments can damage the components of mobile device. The system works by monitoring the temperature, humidity levels etc and when these threshold levels are exceeded the system will sense and alert the user [E.g ringing, vibrating, alert message on display, SMS, call etc]. The mobile device when subjected sudden change in temperature like extreme cold to hot can leads to condensation which can spoil the PCB components, prolonged exposure to extreme temperature can also damage mobile components like sunlight [can damage display, pcb components], extreme temperatures can even spoil the battery etc. Sometimes the user might place the mobile device in extreme hot or cold environments like mobile device near the exhaust of laptop, phone placed near AC vent, mobile device placed in extreme sun [and forget to take the mobile device], kept in a shopping bag and placed inside fridge etc are the scenarios where the mobile device itself will sense the extreme conditions and accordingly alert the user through ringing, vibrating, voice alert and if the system could not grab the attention of the user, it even SMS and make a auto call to preconfigured numbers [other mobile or landline numbers] thereby to protect the mobile device. The sensor system **220** senses the temperature, moisture or humidity etc and generates the trigger signal **230**. The processing unit **150** computes the trigger signal to sense the regarding extreme temperature, humidity and moisture thereby to accordingly alert the user to protect the mobile device.

[**037**] In yet another aspect of present invention a smart active mobile device protection system is designed & developed utilising sensor system **220** to sense the unauthorised access to mobile device thereby alerting the mobile user to protect mobile device from theft and tracks device in real-time from the moment the device is lost. Mostly the user don't lose their mobile device when kept in hand, pocket or pouch and often lose when the device is kept away from the user [on table, desk etc] during scenarios where concentration on tracking the mobile device divert due to meeting, relaxing, chatting, movies, usage of wireless headset, sleeping, charging, prolonged downloading or multimedia streaming or data transfer, silent mode etc. When the mobile device is out of sight or away from the user it is practically difficult to always keep an eye or track the device from losing it to someone. As the mobile devices is away from the user this gives

the intended person an easy access to take the mobile device or even some times if a person want to access personal or critical information about the mobile user which happens without the knowledge or alerting the actual mobile user. But at the same time when mobile user gets a phone call, SMS, mail etc the user is alerted by ringing, vibrating, illuminating etc and the user attend it accordingly. So when enabled [and placed] the device protection system either sense the change in sensor system **220** parameters or scans & senses the current sensor system **220** status and await for the change in status, also acknowledging the user [E.g. with through display, tone, beep sound etc] when the system is active after enabled so the user can move on. The sensor system parameters taken into account are like device proximity environment [with property], orientation (accelerometer, gyro sensor etc), compass (to sense turn & change in direction), position, location (GPS), altitude [altimeter] etc. Either authorised or unauthorised physical access made to the mobile device leads to change in following parameters like device proximity environment, orientation, position, location, direction, touch screen or press of a button etc which is sensed by the system. When a change in status is sensed the system initiates immediate authentication process which should to be completed as per the user pre configuration. When authentication process is completed successfully as per configuration the system won't alert, but if not authenticated the system will start alerting the user by ringing, vibrating etc as per configured settings.

[038] This may looks little odd as this can leads to annoying the actual mobile user by unnecessary alert [like ringing] within time of authentication when accessing their own device. As the authenticating can take few seconds [depends upon authentication type & user handling nature] the system has a provision where the time settings can be configured by the user between disturbed time and authenticating time. When authentication is completed successfully in time the system won't alert, but if not authenticated in time the system will start alerting. For example time taken for user taking a mobile device and authenticating can be done in seconds like figure print scanning, touch screen gesture, face & iris recognition etc. The authentication process can be completed within fraction or few seconds in case like finger print etc where the user when taking the mobile device itself by placing the most convenient finger [preconfigured] on device for authentication. In case of scenarios like wireless headset [E.g. Bluetooth headset etc] the user can also be immediately alerted [through voice alert or ring tone] regarding unauthorised access through wireless headset or similar wireless devices like watch etc. The system when activated also sense and act according to configurations for incoming calls, sms, mms, mail etc [E.g. user can authenticate and attend (user configurable), there after resume protection depends upon requirement]. With this application the user can make sure only authenticated access can be made to device, calls, SMS, mails etc when away or out of sight. Either the user can make use of standard predefined configurations or can configure [fine tune] the following parameters according to his requirement like – type of authentication, sensor system parameters, sensitivity of sensor system, alerting methods, timings etc. Even the sensitivity of the sensor system **220** can be tuned [to

various threshold levels] according to device usage environments & scenarios. Authentication methods can be selected from finger print, password, touch screen gestures, voice recognition, face & iris recognition etc. With these, the system provides the user with features form simple to highly configurable options and settings.

5 **[039]** The system utilise an application for interacting with the user and user can configure the system according to requirement. The mobile device is either configured through application software or by just selecting the profile modes [Active Mobile
10 Protections System or tracker] like general, silent, offline etc where the profile is either predetermined or configurable. Alerting & tracking types are user configurable and are selected from either one or combination of ringing, vibrating, illuminating, SMS, MMS,
15 call, mail, active location tracking, photos & videos, online web tracking, unauthorised figure print tracking, voice, iris & face tracking, alerting through wireless device like headset, watch and ring etc. When the actual mobile user came to know about the unauthorised access or theft, the user can immediately check the tracking information
20 for further action. The system can be enabled, disabled and configured according to user requirement and scenarios like user going to relax, sleep, attend a meeting, charging, movies, music etc. To further enhance the protection system in scenarios like even after alerting the user if the system cannot grab the attention of the user, to further continue with tracking the application is provisioned to turn on and track with camera,
25 mic, touch screen, unauthorised figure print and location or position sensing system [E.g. GPS] in a hidden mode thereby to monitor the activity of unauthorised access locally and also can actively update the activities & collected information's to preconfigured storage locations or sending alert SMS, MMS, mails etc to other configured devices or locations. When an unauthorised access is made and the mobile
30 device start alerting by ringing, vibrating etc can physiologically disturb the intension of the person to proceed ahead thereby protecting the device immediately and alerting the user [even ringing volume can be set to maximum and tones are configured according to user requirement]. The alerting can be stopped when the actual user authenticate with the device. To further enhance the protection system the information collected E.g.
figure print, voice, photo, video etc as per configuration etc between disturbed time and authenticating time can also be temporarily stored and deleted if the authentication is successful, but if not successful it is utilised for further tracking

[040] Even without SIM card the system automatically tries all other possible communication systems & connects with feasible communication system for continuous
35 tracking and alerting. For example [without SIM card or mobile network not available] the system scans available & feasible Wi-Fi hot spots [may be Free hotspots] for further tracking [E.g. active location tracking etc]. This also helps to even track mobile device without mobile communication feature E.g. device with Wi-Fi only. Activated protection system sense the unauthorised access made with authentication failed or not
40 authenticated and will continue alerting as per pre-configuration even if the battery removed & replaced, without SIM card, irrespective of change in SIM card and device turned off and on. Location information [E.g. GPS] provided by the system is correlated with already available maps in real-time to actively and more precisely track the location

of the mobile device with dedicated application or online web tracking. The system optimises the tracking information sent according to the communication system and its channel capacity. Protection system has a user configurable provision to initiate auto turn on function with hidden mode for continues alerting. Protection system can works
5 in application level, operating system level and hardware level depends upon design, requirement and scenarios to prevent the unauthorised reset of the system. Hardware level and online authentication is utilised by the system to prevent the unauthorised protection system restore through operating system or software reset. This helps the user to actively monitor the mobile device from the moment it is lost. The system has a
10 provision for failed authentication recovery configuration which is user configurable and utilised by actual mobile user to stop alerting and restoring the system. In the mean time of authentication and recovery the system will provide only limited access to other device functions [user configurable] expect for failed authentication recovery. The system utilises the mobile device existing sensor system **220** components with
15 application software for its operation which makes the implementation easy and reduce implementation cost. The processing unit **150** manipulate the information based on configured application and nature of trigger signal **230** from sensor system **220** to alert the user with tracking the mobile device accordingly. The protection system can also be configured to automatically enable when mobile device in prolonged ideal state for more
20 than time configured by the user. In case if the user forgets to take the mobile device the protection system has a provision for secure remote access to configure and enable from other devices [E.g. mobiles, computers, laptops, tables etc]. Also the system can interoperate with other ambient intelligent systems like home & office ambient intelligent system, wired or wireless networks [E.g. Wi-Fi, DLNA] etc to alert the user in right place
25 regarding the unauthorised access E.g. user might place the mobile device in one room and available in different room. The home and office ambient intelligent system sense the user presence and alerts [through lights, voice message, ring tone etc] in the place where the user is available so that the users are made aware to take further action. In case of wireless network the user is alerted through audio and video systems [when
30 watching movies, listening to music, meeting, working in gym etc] by sensing the user [even actual user with face and iris recognition] to sense the availability of the user. The use of the system is not limited to one or combination of above scenarios but can also be enhanced to others scenarios and combinations not listed here provided the scenarios are within the scope of the present invention.

35 **[041] FIG. 5** is the flowchart describes the method of operation of the system according to the invention. By starting with **210** the sensor system **220** determines the change in device proximity environment with property, range, visual & IR sensing, device orientation, location, position, operating modes, usage scenarios of the device and will accordingly generate the trigger signal **230**. The system sense the state of trigger
40 signal, degradation in signal quality and other matching parameters or scenarios to decide on further action **240**. The system analyse the nature of trigger signal, precisely sensing the effect of proximity environment, direction of proximity environment with respect to device, magnitude of impedance mismatch [SWR & return loss] with lookup

table, radiation pattern distortion levels, user detection, location, position, device (antenna) orientation sensing, power loss due to PLF, sensing user [body, head & hand hold effects], effect of mobile device platform, pre shared information & parameters, usage scenarios & operating modes in addition to existing signal quality parameters like gain, Received Signal Strength Identifier (RSSI) or Active Set Update (ASU), antenna sensitivity, signal strength to signal quality ratio, location, position, Signal to Noise and Interference Ratio (SNIR), Total Isotropic Sensitivity (TIS), transmit power level, Total Radiated Power (TRP), transmit power level, channel capacity in an active, adoptive and closed loop manner to compute the best control signal for controlling the radiation pattern **250**. Based on the control signal the antenna system shape and optimise the radiation pattern accordingly to achieve the best signal quality with reduced SAR **260**. If the phone is not in proximity to the environment [that can affect the radiations] or not matches other criteria the system will follow the standard transmission **270** according to preset network configuration and ends with **280**.

[042] FIG. 6 Illustrates the model of proximity sensor sensing the proximity environment and user. Nature of mobile device proximity environment changes depends upon usage scenarios which significantly influence the antenna performance due to electromagnetic interaction with the environment [based on its nature or properties] and have effects on radiation pattern distortion, input impedance, gain, efficiency, attenuation, fading, reflection, absorption or lossy environment etc. Since the property of proximity environment changes over time to time depends upon device usage just detecting the change in proximity environment without its property is not sufficient in controlling or shaping the radiation pattern as this approach could not determine the actual effect or radiation pattern distortion levels and shaping without property sensing can also leads to negative effects in signal quality. As sensing of proximity environments nature or property is more important the proximity sensor system utilised for the design not just detect the change in proximity environment but also sense the property or nature of proximity environment to actively optimise the radiation pattern accordingly. This is achieved by making little more sophistication or enhancement to the proximity sensors already available in the mobile devices present days. In general the proximity sensor system works by generating the field [E.g. electric field] and measuring the attenuation suffered by the field there by detecting the proximity environment with property [comparing with predetermined & tested lookup table]. As the proximity environments are mostly dielectric, conductive or its combinations in nature the property sensing is mainly based on dielectric permittivity, conductivity and can be extended to sensing other like permeability, susceptibility etc depends upon system design. The system precisely senses the nature of the proximity environment and level of radiation pattern distortion to actively optimise the radiation pattern thereby to achieve signal quality, protect the user and saves battery power. As the proximity sensors have certain limitations in extending the range of sensing the proximity environment and even attempting to extend the range can leads to other design complications like sensor size, power consumption etc, the present system utilise visual & infrared sensors with range sensors for sensing environment after

certain range. Proximity sensors, visual or thermal sensors, range sensors, orientation sensors etc are all smartly inter operate and synchronise with each other sensing the environment thereby to precisely optimise the radiation pattern.

5 **[043]** As the sensitivity of the proximity sensor differs from that of the antennas the system utilise a predetermined and tested field mapping table or threshold level or
lookup table that are comparison tables [for sensing and matching nature and effect
caused by the proximity environment for further computing] designed and developed by
testing the effect of different proximity environments at various frequencies [according
10 to real world scenarios] on radiation pattern or fields between antenna and proximity
sensor thereby to compare the effect and actively optimising the radiation pattern
accordingly. The performance evaluations are performed according to various antenna
& device designs taking different device proximity environment, operating modes, signal
quality parameters, usage scenarios into account and are analysed, predetermined and
15 tested to real world scenarios for computing the field mapping table there by to achieve
signal quality, high data transfer rates and user protection. To further enhance the
performance placing or positioning of one or more proximity sensors [sensor arrays on
either one or double or multiple sides] on the mobile device is also optimised according
to the antenna locations, device designs and related parameters so that the proximity
environment sensing and computing can work efficiently in sensing the environment.
20 The resolution of the threshold or field mapping tables are fine tuned depends upon the
design and requirement. The system works based on either sensing just the property or
sensing the property and comparing with the tables to actively shape the radiation
pattern. Combination of proximity environment with property sensing, change in
antenna input impedance, return loss or SWR, gain, radiation efficiency, near and far
25 fields, loss monitors, frequency of operation, channel capacity, usage scenarios or
operating modes etc are taken into account for manipulating predetermined and tested
field mapping table which helps the system to determine the direction of proximity
environment and effect caused by it more precisely so that the system can shape or
optimise the radiation pattern efficiently.

30 **[044]** Detuning of the antenna is yet another consequence of user interaction. When the
mobile device [its antenna] is placed in proximity to the lossy human tissue like user
head, hand [hand hold effect], body and other proximity environments shows
degradation in antenna performance which is visible in input impedance, radiation
pattern distortion, gain, efficiency, return loss etc, all as a function of frequency. The
35 interaction between the user and the user equipment [UE] exists in different forms
based on UE types, usage scenario and the applications. For example, smart phones
have versatile applications and thus several forms of user interactions exist. Regarding
the antenna design for handsets, the requirements are mainly based on voice
application, message and packet-oriented communications thus the required test
40 scenario is performed with the user head and hand present [so-called talk position] and
the testing requirements are extended to other usages like data transfer scenarios (e.g.,
file download, browsing, games mode etc). Various user proximity environments are
analysed predetermined and tested to real world scenarios [like direct phone call

conversation, head and hand hold effect etc] for the manipulation of the threshold level table. The user body have a band of dielectric values [permittivity depends upon skin, fat, muscle, bone, cerebrospinal fluid, brain tissue etc] which are utilised for the processing and developing the lookup or field mapping tables. In case of other than call
5 conversation or mobile device away from the user the device is often placed upside or upside down mostly on a homogeneous medium where the available sensor on front and rear [sensor arrays located as per the design] can sense the environment for further processing. The sensor system can also be utilised for sensing biological tissues in scenarios like direct phone call conversation or in internet access & download mode
10 kept in a pocket where the system can protect the user as well as optimising communication. When an antenna system is utilised as a sensor [E.g. Impedance mismatch, SWR or Return loss etc and its related parameters], it can help in sensing proximity environment to certain extent as it is intended for communication, but the dedicatedly designed sensor system can help to more precisely sense the environment.
15 Suitable proximity sensor [active and passive] are utilised by the sensor system, examples are as follows but not limited to electromagnetic or electrostatic sensors, acoustic, inductive, thermal, echo, capacitive, infrared, eddy current etc.

[045] FIG. 7 Illustrates the models of 2x2 and 4x4 MIMO antennas arrays with proximity and orientation sensors in a mobile device. In case of Multiple-Input Multiple-Output antennas the performance of MIMO is very sensitive to the implementation of the antennas, the environment in which the devices is being used and even the orientation of the device itself. This means that a small change in the position of the device when in use can result in significant change in data rate. For example, the user experience of a streaming video could go from excellent to marginal or poor just because the device was moved slightly during use. Moreover, the presence of user hand and body cause radiation pattern distortion or detuning of the antennas and absorption of the radiation power, thus affecting the efficiency and correlation performance of the antenna array. The constant mobility of the mobile device when in usage further reinforces the need for sustaining performance. LTE [4G/4.5G] mobile devices rely heavily on MIMO antenna technology to maximise data transfer rates that can be delivered to mobile subscribers. The actual data speeds experienced by the user are highly dependent on how well a mobile device performs under the range of harsh mobile environments it encounters in the real world. So the dynamic radiation pattern shaping and optimising based on sensing proximity environment and device orientation with other signal quality parameters helps to optimise signal quality with data rates and also protecting user form radiation.

[046] So the present invention with MIMO or antenna arrays [Adaptive arrays] and smart antenna system can enhance the fine tuning & optimising of radiation pattern through controlling gain & directivity, shaping, switch between multiple radiating elements, adaptive beam - forming, steering, polarisation matching, spatial processing & filtering etc, based on sensing device proximity environment, orientation, position, channel capacity with existing signal quality parameters to efficiently enhance the signal quality, protects user and to save battery power. In case of antenna arrays or MIMO the

system senses the change in device [antenna] orientation between corresponding devices and the antenna system is reconfigured, switch between multiple antennas or exiting phase is varied accordingly to match the polarization thereby to optimise the PLF. The system utilising adaptive beam forming with MIMO [antenna arrays] by sensing device proximity environment and position for transmitting and receiving signal in different directions eliminates the need for mechanically steering the arrays. Antenna arrays or MIMO antenna system utilise multiple antennas may also be responsible for battery drain, which is especially problematic with continuous internet access, download, streaming video, online games etc. In case of antenna arrays or MIMO as the number of antennas increase balancing the battery power becomes more important and the proposed system helps to improve the battery life [by focusing the radiation in right direction, power and time]. For example in a 2x2 MIMO antenna system the radiation pattern can be varied by toggling between 2 antennas or varying the gain, directivity and transmit power levels of 2 antennas [MIMO radiation pattern] based on sensing device vicinity environment, orientation, position, operating modes etc. With tuneable metamaterial or EBG in combination with MIMO antennas or antenna arrays can further enhance in fine tuning the active dynamic radiation pattern. Multi directional antenna amplification is performed based on sensor system parameters and usage scenario or operating modes thereby data transfer rates [voice or packet] are optimised between or across the antennas [E.g. antenna arrays] controlled by antenna system with signal quality parameters & channel capacity [MIMO arrays strongest or maximum to least channel capacity]. The sensor system can also use dynamic variable ground plane to actively vary the radiation pattern. The system can be enhanced to adopt with antenna arrays more than 2x2 MIMO like 4x2, 4x4 etc and so on depends upon design.

[047] FIG. 8 Similarly in case of Wi-Fi, Bluetooth, Wimax, ZigBee etc and similar wireless communication systems where the wireless devices are handled in different proximity environments, orientations, position etc according to usage which affects the performance of the antenna like radiation pattern distortion, antenna detuning, input impedance, polarization mismatch etc. The same sensor system [proximity with property sensing, orientation sensing system etc] used for optimising the radiation pattern on mobile communication can be enhanced accordingly to adapt to other possible communication systems. In case of laptops the Wi-Fi or Bluetooth antennas are generally located on the top of the display and sometimes the user might initiate download and close the lid or display. The opening and closing of the lid leads to change in proximity and orientation of the antenna and so the system works by sensing the proximity with orientation and angle of the lid [angle lookup table for sensing angles]. The communicating devices [E.g. Wi-Fi, Wi-Max, Bluetooth etc] actively shares the information depends upon communication system and acting modes of devices regarding parameters like device proximity environment, device [antenna] orientation, location, position, altitude, signal quality to make sure that either one or more devices antenna system optimise the radiation pattern shape, transmit power level and reconfigure antenna to match polarization etc accordingly. The system also utilise similar type field of mapping table or threshold level comparison tables designed and

developed according to these communication systems for comparing related parameters to enhance performance. The processing unit compute to optimise the radiation pattern either based on standalone device parameters or based on actively shared parameters between communicating devices or its combinations. In case of one to one communication [E.g. Wi-Fi direct, Bluetooth data transfer] either one or both the device optimise the radiation pattern between each other and in case of multiple devices exist in communication systems [E.g. Wi-Fi infrastructure (Access point) or adhoc, Bluetooth mesh network] the entire communicating devices actively shares the related information between each other and optimise radiation pattern with smart antenna system accordingly.

[048] The sharing of information is utilised with master/slave architecture like for example in a Wi-Fi network wireless access point acting as master and other connecting devices as slaves or clients where the client devices connecting the master actively optimise antenna radiation pattern according to actively information shared with master and in case of wireless adhoc one to one or mesh the communicating devices shape & optimise the radiation pattern between each other accordingly with shared information to achieve best signal quality. In case of multi access wireless network optimising the radiation pattern is performed between actively communicating devices. The antenna system of the communicating devices tries to match or optimise to either one common or reference polarization [predetermined] else based on the actively shared information between devices to optimise orientation of all devices. The system has a provision for configuring the access points to broadcast its location information [E.g. GPS or AGPS, Wi-Fi positioning system etc] with which the connecting devices can detect the direction & location of the access point based on which shaping and optimising the radiation pattern is performed accordingly. As the resolution of GPS is more than that of the coverage of systems like Wi-Fi, WiMax etc and nowadays users are utilising GPS or AGPS etc constantly for some application like social websites in mobile to convey user current location information, are utilised in one to one communication between devices with sensing device direction to shape or optimise radiation pattern between them. As the Wi-Fi, Bluetooth etc utilising MIMO antenna arrays to increase throughput [Wi-Fi - 802.11n, Bluetooth] consumes significant amount of power and the system not only enhances signal quality and data throughput performance but also saves battery power during continuous data transfer like Internet access, Streaming, downloading, games etc. Following are the example where the system can be utilised - In case of Wi-Fi the communication between devices like access points, laptops, tablets, mobile devices, smart TV, wireless printers etc [acting modes might be Infrastructure or Ad-Hoc mode, Wi-Fi access point, Wi-Fi direct, Wi-Fi tethering, Wi-Fi modems, wireless DLNA devices, streaming etc] and Bluetooth devices like mobile phones, laptops, tablets, gaming devices, headset, printers etc [acting as data transfers between devices, mobile acting as modem for internet access etc]. [Wi-Fi is a registered trademark of Wi-Fi alliance, WiMax is a registered trademark of WiMax Forum and Bluetooth is a registered trademark of Bluetooth SIG Inc, ZigBee is registered trademark of ZigBee alliance].

[049] There are many ways to achieve and the following are some of the available RF/Antenna system designs capable of achieving dynamic radiation pattern, controlling gain and directivity, beamforming, beam steering, spatial processing & filtering, polarisation matching etc. The dynamic radiation pattern can be achieved utilising tuneable metamaterials or tunable EBG antenna system 110 that provides variable response and ability to influence the interacting electromagnetic waves to determine whether the EM wave is transmitted, reflected, absorbed etc. In general tunable - metamaterials and EBG are most commonly composed of small periodic elements typically built onto circuit boards or assembled using nanofabrication techniques, whose feature size is significantly smaller than the wavelength of the electromagnetic waves they are intended to manipulate. The lattice structure [one, two or three dimension] of the tuneable metamaterial and EBG is adjusted in real time, making it possible to reconfigure the structure during operation. The antenna design of smart signal quality enhancement system works by activating different patterns of tuneable EBG and metamaterial elements that act according to configuration to actively control radiation pattern and radiation intensity in required direction and time. Also the antenna design uses either one or combination of following but not limited to tunable Metamaterials, tunable Electromagnetic Band Gap (EBG), High Impedance Surface (HIS) or Artificial Magnetic Conductor (AMC), Negative Index Material (NIM), periodic arrays, Frequency Selective Surfaces (FSS), Split-ring Resonator (SRR), Reconfigurable antennas, antenna arrays, MIMO antennas, reconfigurable multifrequency microstrip patch antenna, antenna diversity, adaptive arrays, Micro Electro Mechanical System (MEMS) and the techniques user are Method of Moments (MOM), Computational electromagnetic (CEM) or Electromagnetic modelling, Finite Impulse Response (FIR), Finite-difference time-domain (FDTD) etc with corresponding RF/antenna system and signal processing algorithm to achieve dynamic radiation pattern, beamforming, beam steering, controlling excitation phase, spatial processing & filtering etc. The system can be designed to adopt different multi band antennas with several type of feeding mechanism. The system can also be designed with actively tunable electromagnetic screen [E.g. fabricated with tunable metamaterial or EBG] capable of dynamically controlling or redirecting the radiation from antenna in corresponding directions to vary radiation pattern is either fabricated on printed circuit board (PCB) or incorporated on device casing. The plasma antennas are capable of achieving dynamic radiation pattern and the advantage of these plasma antennas over mechanical antenna are that the plasma antenna are reconfigurable, can operate at high speeds and has no moving parts. Smart ionized gas plasma antennas use plasma physics to shape and steer the antenna radiation pattern without the need of phased arrays etc. The radiation pattern can be steered or focused in the reflective or refractive modes using plasmas making it a unique one. Solid state plasma antennas (also known as plasma silicon antennas) with steerable directional functionality that can be manufactured using standard silicon chip fabrication techniques are now in development. The PSiAN is a cluster of thousands of diodes on a silicon chip that produces a tiny cloud of electrons when charged. Those tiny, dense clouds can reflect high-frequency waves like mirrors, focusing the beams tightly by selectively activating particular diodes. These capabilities

of achieving dynamic radiation pattern can be utilised with the present system to enhance the performance of mobile communication.

[050] When there is a change in transmit power level of fixed radiation pattern, the change will take place with over all transmit power level according to radiation pattern. In general mobile devices like cell phones are designed to have fixed radiation pattern with major radiation pattern on the device rear side or other side facing the user and minor radiation pattern on device front side or user facing direction to reduce SAR also providing communication when major radiation pattern is blocked by usage or placed on platforms [E.g. conductive or dielectric] that affects the interacting waves. So permanently reducing the intensity of radiation on user facing direction for protection can have negative effect on quality of communication based on usage scenario; for example when the device major radiation pattern side is placed on platforms that can degrade the interacting electromagnetic waves which in turn can degrades the quality of communication. Instead of fixed radiation pattern approach the present invention provides an active dynamic radiation pattern solution that can change and adapt according to scenarios thereby provides the ability to actively shape and optimise radiation pattern in direction and time which helps in enhancing the communication and protecting user from radiation. The present invention provides the fine tuning and controllable radiation on the user facing direction while maintaining the radiation on other direction that works according to different usage scenarios & signal quality parameters of mobile device **100** to achieve the balancing between best signal quality and least SAR [so that the quality of communication is not compromised]. Environment sensing like dimension, direction, nature, range etc with diffraction caused by the environments [diffraction limits] are also taken into account in shaping and optimising radiation pattern to sustain omni directional radiation beyond environment according to scenarios.

[051] Already mobile devices use camera [in front and rear] and with little more sophistication these cameras can enhance it sense the human presence [face and body recognition] in day & night, proximity objects, distance, its range or distance calculation. Thermo graphic camera or infrared camera is a device that forms an image or video using infrared radiation, similar to a common camera that forms an image using visible light [visible spectrum] thus provides the system with thermal vision. All objects emit a certain amount of black body radiation as a function of their temperatures. The amount of radiation emitted by objects varies according to temperature, scenarios and nature of objects. Higher an object's temperature is, the more infrared radiation emitted as black-body radiation. The variations in the temperature is utilised by the thermo graphic camera to compute the picture of humans, proximity environments etc easily visible in a dark environment. It works even in total darkness because ambient light level does not matter. The human body have a range of infrared frequency and the present system is designed to actively sense these for further computing. These sophisticated sensors are utilised to enhance the precision of the system in protect the users with most of the scenarios as well as optimising signal quality. The system helps the mobile device to sense and feel the human presence and other proximity environments can be further

utilised for the mobile applications to work more precisely and lot of other potential applications like tracking, games, emergency situations, medical application etc. The sensor system can even be enhanced to precisely sense difference between the actual user and others and can act accordingly [For security, privacy etc]. Applications based on thermography have lot of potential applications and non invasive medical applications like infrared imaging of body, thermometer etc. As the continuous sensing by sensor system can consume battery power the sensors [with least to most power consuming sensors] of sensor system are smartly utilised according to scenarios, usage and operating modes to save the battery power.

[052] Over all combinations of change in proximity environment with property sensing [its radiation pattern distortion levels], position, orientation, [change in] input impedance, return loss or SWR, usage scenario or operating modes and signal quality parameters to optimise the radiation pattern in order to achieve signal quality enhancement, protect the user from radiation exposure and saves battery power. The nature of varying and controlling the radiation pattern with intensity of radiation facing the user is based on combination of parameters while limiting the maximum transmit power level as per the compliance with SAR safety guidelines. The instructions regarding how the radiation pattern is altered are pre determined and tested. The design can works in conjunction with change in overall radiated power by taking signal quality parameters into account to maintain the quality of communication while limiting maximum transmit power levels according to compliance & standards. Thus the design reduces the SAR with optimised communication quality. The system not only enhances signal quality but also saves energy by actively controlling the gain and directivity there by reducing the radiation on certain less effective direction. Mostly as the radiation pattern for transmission and reception is reciprocal these system can help in improving the overall signal quality. The design not only helps in reducing the SAR, but also can reduce the interference with other systems like pacemaker, hearing aid etc. The system can both be automatically & manually enabled and disabled with hard or soft or combination switch depends upon the design and usage.

[053] The embodiments of the present invention is not limited to listed scenarios described here or its combinations and the above presented are just examples. There may be other scenarios and those who skilled in field can understand and modify, enhance, alter the herein system without departing from the scope of the invention in its widest form.

CLAIMS :

1. The smart active antenna radiation pattern optimising system for wireless mobile device comprise of

- 5 a) A sensor system to actively generate trigger signal by detecting the change in parameters comprise of device proximity environment particularly with property [nature] sensing, sensing proximity [vicinity] environments - direction, dimension, multilayer, range [distance] & position with respect to device, simultaneously sensing multiple proximity environments surrounding the device, visual & infrared sensing, user recognition through property sensing, 10 device [antenna] orientation sensing, direction & location sensing, MSP [Mobile sensing Platform] & ambient intelligence, detecting operating modes and usage scenarios of the device.
- 15 b) A processing unit for the computing the control signal based on parameters comprising of trigger signal from sensor system, effect of proximity environment on antenna [radiation], user proximity with head, body & hand hold effects, computing proximity environments - direction, dimension, multilayer, distance & position with respect to device, antenna detuning effects, effect on near & far fields, change in impedance, magnitude of radiation pattern distortion, sensing human presence with direction, dimension, 20 range with respect to device, face & iris recognition, SWR or return loss, antenna orientation, excitation phase, predetermined parameters, actively shared parameters between communicating devices, lookup tables, RSSI, channel capacity and other existing signal quality parameters thereby to optimise antenna radiation pattern to enhance signal quality by directing radiation on feasible & right direction, protect the user by reducing radiation exposure on user facing direction and to save battery power by controlling radiation in less effective directions.
- 25 c) Smart radiation pattern optimiser that act according to the control signal.
- 30 d) Smart antenna system capable achieving dynamic radiation pattern is coupled with radiation pattern optimiser that actively controls, shapes and optimise the radiation pattern according to scenarios. Also the system comprise of smart reconfigurable antenna system with the knowledge of relative antenna orientations to actively match the polarisation thereby to increase gain and control Polarisation Loss Factor [PLF].
- 35 e) Smart RF/Transceiver system with signal processing capability which is a combination of transmitter and receiver coupled with radiation pattern optimiser. The system utilise signal processing capability & algorithms to act according to scenarios.
- 40 f) The system actively sense, shapes & controls the radiation on user facing direction and affecting proximity environments while maintaining the radiation on other directions to sustain communication. Besides controlling the direction of radiation based on nature of proximity environment and reconfigure antenna system to match polarisation; the system actively restores radiation pattern according to scenarios to optimise communication. The system actively sense 45 multiple proximity environments surrounding the device and checks for

appropriate space & proximity environment based on its property, dimension, direction, range, location, position, device orientation, usage scenarios, operating modes and signal quality parameters for selecting the best feasible directions to actively shape and optimise the radiation pattern.

- 5 g) The system comprise of hard, soft and combination switches according to the design for enabling and disabling the system.
2. The mobile device said in claim 1, comprise of sensor system that works based on one or combination of sensors, operating modes and usage scenarios.
- 10 a) The sensor for sensor system is selected form the group comprising of proximity sensors, distance [range] sensor, optical sensors, visual & infrared sensors, 2D & 3D [dimension] sensors, orientation sensors, accelerometer, gyro sensor, directional sensors, E-compass or magnetometer, position & location sensor, temperature sensor, humidity & moisture sensor, ultrasonic sensors, altitude sensor, belt pouch sensor, clip sensor, cradle or holster sensor.
- 15 b) The proximity sensors and sensor arrays capable of scanning, detecting and sensing the change in property [nature] of different proximity environments and various biological tissues with its direction, dimension, positions, multi layers & range with respect to device there by precisely sensing user head, body & handhold effects, effects of platform & environment on mobile device. The parameters utilised for sensing comprise of permittivity- ϵ , permeability- μ , conductivity- σ , susceptibility, dielectric, capacitive sensing, capacitive displacement sensing, inductive sensing. The sensor system utilise one or more proximity sensors or sensor arrays optimally placed in various locations & positions according to device design for more precisely sensing in all possible directions. The proximity sensor are selected from electromagnetic sensors, electrostatic sensors, acoustic, inductive, thermal, echo, capacitive, infrared, eddy current, ambient light, active & passive sensors.
- 20 c) Gyro sensor, accelerometer, inclinometer, E-Compass or magnetometer to sense the change in orientation and direction of the mobile device. The sensors utilised are selected with one to multi dimension and axis sensing capability.
- 25 d) One or more sensors or cameras with visual, infrared [thermo graphic], ultrasonic and its combinations are optimally located in the mobile device according to the design for scanning & sensing the environment, user presence, face & body recognition with autofocus, iris recognition, imaging, scanning & sensing in multi direction & dimension, computing distance [range] of user & other proximity environment with respect to device. The infrared cameras utilised comprise of active infrared, passive infrared and its combinations. The system utilises 360 degree or omnidirectional sensors & cameras [visual & IR], popup cameras, existing front & rear cameras, side cameras, 2D & 3D cameras with the lenses utilised comprising of regular camera lens, super ultra wide angle lens, fisheye lense, extreme angle broadband metamaterial lenses, tuneable metamaterial lenses, super lenses, opto fluidics lenses, tuneable lenses ultimately for scanning and detecting the environment in all possible direction. According to design & scenarios the
- 30
- 35
- 40
- 45

system utilise fisheye lens for sensing the change in environment and utilise other appropriate feasible lens cameras for further tracking of the objects in the environment.

- 5
- e) Distance or range sensors and cameras are selected from the ultrasonic range sensor, infrared range sensor, electromagnetic range sensors, acoustic range sensor, visual range sensor, photo electric range sensor that are optimally located to sense the range of user and proximity environment with respect to mobile device in all possible directions.
- 10
- f) Optimally located one or more thermo graphic or IR sensors, temperature sensors, sensors detecting proximity environments property with multilayer sensing, ambient light sensors, electromagnetic sensors, orientation sensors, sensing usage scenarios and operating modes with predetermined & tested lookup tables are utilised to more precisely sense the mobile device in user pockets & pouch with orientation.
- 15
- g) MIC and ambient light sensor to sense the change in sound and ambient light level on the environment of the mobile device.
- h) Temperature, moisture and humidity sensors to sense the environment of the mobile device.
- 20
- i) The operating modes and usage scenarios comprising of direct phone call mode, speaker mode, hands free mode, headset detection, video call mode, Bluetooth mode, detecting key pad & touch screen usage, display orientation, Wi-Fi mode, internet access & browsing, download mode, games, streaming, standby mode, sensing data transfer and wireless modem mode.
- 25
- j) Position & location systems are selected from GPS, AGPS, GLONASS, satellite based positioning system, WiFi positioning system, cell sight positioning system, bluetooth positioning, Hybrid positioning system to sense the location & position of the mobile device.
- k) The sensor system utilising device display itself as proximity sensor and proximity sensor itself as range sensor.
- 30
- l) The sensor system utilise sensors comprising of fixed and tuneable sensitivity & range are selected according to design and scenarios. The sensor systems precision levels, sensing depth of dimension and multi layer sensing are utilised according to design & requirements.
- 35
3. The mobile device of claim 1, comprise of processing unit for computing the control signal. The processing unit works in an active, smart and adaptive closed loop manner with the type and their functions are selected from the group comprising of
- 40
- a) A general purpose mobile processor utilised for the computing the control signal.
- b) A dedicated RF signal processing unit utilised for computing the control signal.
- c) The smart radiation pattern optimiser or RF/transceiver system itself is utilised for computing the control signal.
- d) The interrupt control signal from signal processing unit are utilised for actively shaping and optimising the radiation pattern and for controlling polarization.

- e) As the system work with critical functions of the mobile devices - signal quality enhancement, protecting user form radiation, saving battery life a high priority interrupts are assigned for computing and signal processing.
- 5 f) Correlation tables or lookup tables are the comparison tables that are saved in memory of mobile device and are utilised by the processing unit to actively check and compare the effects between predetermined and tested real world scenarios to the actual real world scenarios with which the system precisely sense the user and various proximity environments with usage and operating modes to actively shape & optimise the antenna radiation pattern accordingly in a smart, adaptive closed loop manner to protect the user while maintaining signal strength to signal quality ratio.
- 10 g) The processing unit utilize predetermined and tested field mapping table or lookup table for sensing, comparing, computing and matching the effects between sensor system parameters and antenna radiations thereby to actively optimise the radiation pattern.
- 15 h) The processing unit according to communication system and corresponding acting modes of the devices actively shares information and utilise one or more parameters between the communicating devices to direct, shape and optimise the radiation pattern between devices. The parameters shared comprising of devices proximity environment with property, device orientations [antenna orientation], position & location, range, altitude, in addition to existing signal quality parameters.
- 20 i) As multiple parameters are taken into account by processing unit for computing beam forming vector, shaping & optimising the radiation pattern the processing unit optimise the performance by taking one or more parameters according to scenarios, communication system design and acting modes with ultimately prioritising & optimising to achieve best signal quality, protect user by reducing radiation exposure levels and to save battery power.
- 25 j) The processing unit computes and controls the antenna system of the communicating devices to match [optimise] to one common or reference polarization [predetermined one] else based on the actively shared information to optimise the polarization of all communicating devices.
- 30 k) The processing unit utilise either analysed, predetermined and tested lookup tables designed & developed with different orientations of the devices [antenna] or based on actively shared information to reconfigure the antenna system in real time to dynamically synchronise with change in device [antenna] orientation to match the polarisation between or with respect to corresponding communicating devices thereby mitigating the power loss due to polarization mismatch and to control polarisation loss factor [PLF].
- 35 l) As the processing unit utilise multiple sensors & parameters the system smartly coordinate between the sensors to optimise the performance and to save battery power. The processing unit active & smartly toggle between multiple feasible and associated sensors according to scenarios, usage & operating modes for continuous sensing and acquiring tracking parameters thereby to enhance the precision of the system and to save battery power. The
- 40
- 45

processing unit controls the sensor system to smartly turns off the out of scope sensors accordingly to save the battery power.

- 5 m) The processing unit utilise Digital Signal Processing [DSP] and Digital Image Processing [DIP] to compute the information from the sensors. The sensor system parameters are utilised by the processing unit for user recognition, face recognition, iris recognition and environment sensing with dimension and range.
- 10 n) The processing unit performs multi directional antenna amplification based on sensor system parameters, usage scenario, operating modes, signal quality parameters and channel capacity thereby the data transfer rates [voice & packet] are optimised between or across the antennas [E.g. MIMO, arrays].
- 15 o) The processing unit compute to optimise the radiation pattern based on sensor system parameters, signal quality parameters, usage and operating modes, predetermined and tested lookup table, actively shared parameters between communicating devices.
- p) The processing unit utilises antenna system itself as a proximity sensor.
4. The mobile device said in claim 1, comprise of smart RF antenna system with signal processing capability for actively optimising radiation pattern through radiation pattern shaping, controlling gain & directivity, adaptive beamforming, beam steering, switching, antenna diversity, spatial processing & filtering, spatial diversity, diversity gain, pattern diversity, polarization diversity, reconfigure antenna system & controlling excitation phase to match polarization, multidirectional antenna amplification, controlling transmit power levels are selected from one or combinations comprising of
- 20 a) Antenna system utilising MIMO and antenna arrays.
- b) Antenna system utilising [tunable] metamaterials and Electromagnetic Band Gap (EBG) fabricated antenna.
- c) Antenna system utilising plasma and gas antennas.
- 30 d) Antenna system that utilise one or combination of tunable – High Impedance Surface (HIS) or Artificial Magnetic Conductor (AMC), Negative Index Material (NIM), periodic arrays, Frequency Selective Surfaces (FSS), Split-Ring Resonator (SRR), reconfigurable antennas, Flexible Printed Circuit (FPC) board antennas, reconfigurable multi frequency microstrip patch antenna, Micro Electro Mechanical System (MEMS), planar or non coplanar antennas,
- 35 e) Antenna system utilise one or combination of techniques relating to spatial processing and filtering, Method of Moments (MOM), Computational Electromagnetics (CEM) or Electromagnetic Modelling, Finite Impulse Response (FIR), Finite-Difference Time-Domain (FDTD), diversity techniques.
- 40 f) Antenna system design comprise of one or more radiating element that supports single band, dual band, triple band, quad band, penta band, multi band frequencies with related parameters to achieve dynamic radiation pattern.
- g) Antenna system utilising internal antennas, external antennas and its combinations with various locations and feeding mechanisms.
- 45 h) Antenna system utilising antenna arrays, diversity techniques, adaptive arrays, flexible antennas and PIFA arrays.

- i) Antenna system utilising reconfigurable antennas to shape and optimise radiation pattern.
- 5 j) Antenna system utilising reconfigurable antennas to actively vary & match the polarization to control polarization loss factor [PLF]. Antenna system actively senses the change in relative device [antenna] orientation between communicating devices thereby reconfigure the antennas and vary excitation phase accordingly to match & optimise polarization.
- k) Antenna system works in an active, adaptive & closed loop manner with sensing, computing and optimising radiation pattern.
- 10 l) The antenna system sense the signal quality degradation and trigger the processing unit to check with sensor system parameters thereby to compute and optimise the radiation pattern for enhancing the signal quality.
- m) Antenna system comprising of common and dedicated antennas for transmission and reception.
- 15 5. The mobile device of claim 1, further comprise of a transceiver circuit or RF system that transmit and receive signals. The circuitry is selected from
- a) Circuitry consist of combination of both transmitter and receiver
- b) Circuitry consist of separate transmitter and receiver
- 20 6. The lookup table said in claim 3, comprising of field the mapping tables, threshold level tables, correlation tables that are the comparison tables saved in memory of mobile device and are utilised by the processing unit to actively check and compare the effects between predetermined and tested real world scenarios to the actual real world scenarios with which the system actively shape & optimise the antenna radiation pattern accordingly in a smart and adaptive closed loop manner and also for precisely sensing the user, various proximity environments and usage scenarios.
- 25 a) The values in the tables are designed and developed by taking parameters - proximity environment with property sensing, effect & range of proximity environments, sensing multilayer of proximity environment, sensing various locations & positions, sensing user, head, body & handheld effects, impedance, gain, return loss or SWR, Received Signal Strength Identifier (RSSI) or Active Set Update (ASU), channel capacity, near field & far field effects, various signal quality parameters, transmit power levels, Signal to noise and interference ratio (SNIR), Total Isotropic Sensitivity (TIS), Total Radiated Power (TRP), device [antenna] orientations, polarization loss factor (PLF), oblique instincts, visual & thermo graphic sensing, effect of mobile device platform, user body band of dielectric values, user body band of infrared frequencies or wavelengths, operating mode and usage scenarios are all tested at various real world scenario and frequencies are utilised by processing unit according to scenarios and communication system design.
- 30 b) These parameters and its values in the table are utilised by the system to determine the change in proximity environment with its property & direction, user sensing [with band of body dielectric values & IR frequencies], conductive & dielectric nature, magnitude of radiation pattern distortion, location & position, antenna orientation and its effects caused more precisely thereby to shape & optimise the radiation pattern accordingly.
- 35
- 40
- 45

- 5 c) The processing unit utilise analysed, predetermined and tested field mapping table or threshold levels table developed by sensing and comparing the effect of different proximity environments on radiation pattern or field distortion between the antennas and proximity sensor system. The tables contain values of parameters comprising of dielectric, conductivity values to more precisely sense the nature of environment and user body band of dielectric values for sensing user.
- 10 d) The processing unit utilise analysed, predetermined and tested threshold levels table designed & developed with different orientations of the devices [antenna] to dynamically synchronise with change in device [antenna] orientation to match the polarisation between or with respect to corresponding communicating devices thereby mitigating the power loss due to polarization mismatch and control polarisation loss factor [PLF]. Orientation threshold levels and corresponding antenna oblique instincts are utilised in designing the table which in turn is utilised to vary & reconfigure the antenna orientation and excitation phase.
- 15 e) The resolutions of the tables are designed, calibrate and fine tuned according to the requirement.
- 20 7. The active sharing of parameters said in claim 3, are utilised by the processing unit according to communication system and corresponding acting modes of the devices to actively shares information's and utilise one or more parameters between the communicating devices comprising of devices proximity environment with property, device orientations [antenna orientation], position & location, altitude, in addition to existing signal quality parameters; thereby to direct, shape and optimise the radiation pattern between devices.
- 25 a) The system utilise actively shared information regarding proximity environment with property, usage scenarios, operating modes, existing signal quality parameters, range, location & position, of the communicating devices between to check for the direction and distance with respect to devices thereby to actively direct, shape and optimise the radiation pattern between devices.
- 30 b) The actively shared antenna orientation information is utilised to match polarisation between communicating devices thereby to control power loss due to PLF.
- 35 c) The processing unit utilise Location & positioning system [E.g. GPS] to determine the direction of the communicating devices with respect to each other based actively shared information thereby shaping & optimising radiation pattern accordingly.
- 40 d) The processing unit utilise master/slave architecture according to the communication system and corresponding acting modes of the devices for sharing information where all the clients [slaves] checks with master's information and adopt accordingly.
- 45 e) The processing unit in case of ad-hoc, one to one and mesh network where the devices optimise the radiation pattern between communicating devices and adapt to common or reference polarisation according to the actively shared information.

8. The processing unit said in claim 3, computes the control signal to achieve optimised radiation pattern based on sensor system parameters, signal quality parameters, predetermined & tested lookup table, usage scenarios & operating modes there by precisely sensing the effect of proximity environment based on property, direction, dimension, location, position, range of user and proximity environment with respect to device, sensing user body, head & hand hold effects, device orientation, visual & IR sensing, change in antenna impedance [impedance mismatch], lookup table, actively shared parameters, SWR or return loss, user recognition, power loss due to polarization loss factor (PLF), oblique instincts in addition to existing signal quality parameters comprising of gain, Received Signal Strength Identifier (RSSI) or Active Set Update (ASU), Direction of Arrival (DOA), channel capacity, antenna sensitivity, signal strength to signal quality ratio, Signal to noise and interference ratio (SNIR), Total Isotropic Sensitivity (TIS), transmit power level, Total Radiated Power (TRP) in a active, adoptive and closed loop manner.
9. The antenna system said in claim 4, itself act as sensors in sensing the change in proximity environment based on change in antenna impedance (mismatch), gain, SWR or return loss across the one or multiple [arrays] antennas which are utilised for sensing the effect of proximity environment and its direction with respect to device (antenna) thereby shaping and optimising the radiation pattern according to predetermined and tested lookup table, designed with various real world scenarios and different frequencies according to the system design. The magnitude of change in parameters impedance, gain, radiation pattern distortion, SWR are compared with lookup table and utilised for sensing the effect of proximity environment and its direction. The system works in an active, adoptive and closed loop manner for sensing, monitoring, comparing, computing and optimising radiation pattern to achieve optimised performance.
10. The mobile device said in claim 1, utilise visual & thermal sensors for sensing the user presence with direction, range, dimension and accordingly shape the radiation pattern to protect the user as well as to optimise signal quality
- a) The system utilises one or more visual, thermal or infrared cameras and range sensors that are optimally located in the device to sense the user presence and other proximity environments.
 - b) The cameras and range sensors scans the users and environment in all possible directions with sensing dimension, direction & range of user and proximity environment with respect to device. According to design & scenarios the system utilise fisheye lens for sensing the change in environment and utilise other appropriate feasible lens cameras for further tracking of user in the environment.
 - c) The system works irrespective of availability of light or pitch dark [zero light] environment utilising lookup table with human body's band of infrared frequencies or wave lengths for sensing the user with thermal imaging.
 - d) The system works with existing front & rear cameras and other optimally located feasible cameras and sensors according to design to sense the environment in all possible directions.
 - e) The system works with preconfigured settings and user configured settings.

- f) The system utilise proximity sensors, MIC, ambient light sensors, face recognition with autofocus, iris recognition, active Digital Signal Processing [DSP] and Digital Image Processing [DIP] to enhance the precision in sensing the user and environment.
- 5 g) The system computes the direction, dimension and range of the user and environment with diffraction limits to shape the radiation pattern accordingly thereby to protect the user as well as to sustain signal quality.
- h) The system smartly turns off the out of scope cameras and range sensors based on nature of trigger signal from associated sensor to save battery power.
- 10 11. The processing unit said in claim 3, is utilised with application for guiding the user to select the optimum location and position for using the mobile device in user living space thereby to achieve best signal quality and to save battery power. The processing unit utilise sensor system parameters, signal quality parameters, channel capacity, usage scenarios & operating modes for the computing and
- 15 detecting the optimum location. The system also alerts the user regarding low signal quality and high EMI [Electro Magnetic Interference].
12. The sensor system said in claim 2, are utilised to alert the user regarding the unattended parameters comprising of incoming calls, mails, messages, meeting, to do note, schedule task, alarm etc by automatically sensing the user presence
- 20 once the user is back to environment and within the scope of sensor system
- a) The system utilises one or more visual, thermal or infrared sensors and cameras to sense the user presence.
- b) The system works irrespective of availability of light or zero light environment utilising lookup table with human body's band of infrared frequencies or wave
- 25 lengths for sensing the user with thermal imaging. The system utilise active and passive infrared sensors or cameras for sensing the user.
- c) The system works with existing front & rear cameras with all other optimally located feasible cameras and sensors according to design ultimately to detect the user in all possible directions. According to design & scenarios the system utilise
- 30 fisheye lens for sensing the change in environment and utilise other appropriate feasible lens cameras for detecting the user in the environment.
- d) The system utilise Digital Signal & Image Processing [DSP & DIP], MIC and ambient light sensor to enhance the precision of the system in sensing the users on environment.
- 35 e) The system works with preconfigured settings and user configured settings.
- f) With pre configuration the system utilise face recognition & iris recognition to alert the actual mobile user in case of multiple people exist in the environment and scope of sensor system.
- 40 g) The system alerts & interacts with the user through display, ring tone, vibrating and voice alert or message.
- h) The system comprise of provision for interacting with user and controlling through voice command and recognition that works with or without user taking the mobile device to check the information regarding unattended missed calls, messages, mails and voice control the phone functions of making a phone call,
- 45 message, text to speech & vice versa for message and mails. The mobile device

interacts with the user through voice message, ringtone, display and its combinations.

i) In scenarios user not available in mobile device environment and out of scope from sensor system, the system interoperates with other ambient intelligent systems comprising of ambient intelligent system of home & office, wired & wireless networks to detect and alert the user in right place.

j) The system also turns off the out of scope cameras & sensors based on nature of trigger signal from proximity sensor to save battery power.

13. The sensor system said in claim 2, are utilised to alert the user regarding the unattended incoming calls, mails, messages, meeting, to do note, schedule task, alarm etc once the user takes or moves the mobile device.

a) The system utilises proximity sensors, magnetometer and location or positioning systems [E.g. GPS] thereby sensing the change parameters comprising of proximity environment, direction and location that occurs once the device is taken or moved by the user.

b) The system works with preconfigured settings and user configured settings.

c) The system alerts the user through display, ring tone, voice alert or message.

14. The sensor system said in claim 2, are utilised to alert the user to protect the mobile device when exposed to extreme temperature, moisture and humidity beyond the device operating range

a) The system utilises one or more temperature, moisture and humidity sensor.

b) The system works with preconfigured settings and user configured settings.

c) The system alerts the user through display, ring tone, vibrating, voice alert, messages [SMS] and calls with location or position [GPS] information. In

scenarios user not available in mobile device environment and out of scope from sensor system, the system interoperates with other ambient intelligent systems comprising of ambient intelligent system of home & office, wired & wireless networks to detect and alert the user in right place.

15. The sensor system said in claim 2, is utilised by smart active mobile device protection system to protects and tracks the mobile device in real-time from unauthorised access or theft by alerting the mobile user

a) Enabled device protection system sense the change in sensor system parameters, scans & senses the current sensor system status and expects or awaits for the change in status, acknowledging the user once the system is active after configuration for the user to move on.

b) Sensor system parameters are selected form one or combination of change in device proximity environment (with property sensing), orientation, position, location, direction, altitude, touch screen, power switch, keys, hard or soft buttons.

c) Once a change in sensor system status is detected the system expects & awaits for authentication which should be completed within the set time as per the user pre configuration. On successful completion of authentication the system won't alert, but if not authenticated the system will start alerting and perform further operations as per configuration.

d) Authentication methods & types comprise of password or pin, touch screen input & gestures, figure print, voice recognition, face & Iris recognition.

- 5
- 10
- 15
- 20
- 25
- 30
- 35
- 40
- 45
- e) The system comprise of provision for preconfigured and user configurable time settings to set time between disturbed time and authenticating time.
 - f) Alerting types & tracking comprise of ringing, vibrating, illuminating, SMS, MMS, call, mail, active location tracking [GPS], online Web tracking, dedicated tracking application, unauthorised figure print tracking, voice, iris & face tracking, photo & video tracking, alerting through wireless device comprising of headset, watch and ring. According to user configuration the information or parameters collected in period of unauthorised access is locally saved and [or] sent to & saved in preconfigured locations for further processing. Tracking information's are optimised according to the communication system and its channel capacity. In scenarios user not available in mobile device environment and out of scope from sensor system, the system interoperates with other ambient intelligent systems comprising of ambient intelligent system of home & office, wired & wireless networks to detect and alert the user in right place.
 - g) Even after alerting if the system cannot grab the attention of the user the application works in hidden mode to turn on & track with camera, mic, touch screen, unauthorised finger print, active location or position [E.g. GPS], voice, face & Iris tracking to monitor the activity of unauthorised access locally and with actively & automatically updating the activities & collected information's to preconfigured storage locations and other configured devices. Once the actual mobile user sense unauthorised access or theft, the user utilises the tracking information to immediately check for further action.
 - h) The system utilise user interface [application] that interact with the user to for the configuration of the device protection system. The system comprise of provision for activating & configuring through application software and through profile selection. The system utilise standard predefined configurations and with provision to configure [fine tune] the parameters according to user requirement comprising of type of sensor system parameters, sensitivity of sensor system, authentication types, alerting methods, timing configurations, hidden mode, activation of camera & mic for tracking, position & location tracking live tracking of device, web tracking, SMS, MMS, MAIL, call, ring tone selection & volume levels, vibrator, location and other devices for active tracking and storing collected information. System comprise of provision for simple predefined to highly configurable user interface.
 - i) Activated protection system sense the unauthorised access with authentication failed or not authenticated and will continue alerting as per pre-configuration irrespective of the battery removed & replaced, irrespective of change in SIM card, without SIM card and device turned off & on. In addition to mobile communication the system tries all possible communication systems & connects with feasible communication system for continuous tracking and alerting. System provides tracking information for device without mobile communication feature [E.g. Wi-Fi only].
 - j) From the moment of unauthorised access the activated system collects information and monitors the lost device with location information [E.g. GPS]. The positioning information provided by the system is correlated available with

maps in real-time to actively and more precisely track the location of the mobile device with dedicated application and online web tracking.

- 5
- k) Protection system with provision for failed authentication recovery configuration which is user configurable and utilised by actual mobile user to stop alerting and restoring the system. In the mean time of authentication and recovery the system provides limited access to other device functions [user configurable] expect for failed authentication recovery. The information collected between disturbed time and authenticating time is temporarily stored and deleted on successful authentication and if not successful utilised for further tracking.
- 10
- l) Protection system works in application level, operating system level and hardware level according to design and configuration to prevent unauthorised system restore. In case of device switched off by unauthorised access the system with user configurable provision initiate auto turn on function with hidden mode for tracking in background and continue with alerting. Hardware level protection and online authentication is utilised by the system to prevent the unauthorised protection system restore through operating system and software reset. Protection system comprise of provision to configure and monitor through secure remote access from other devices. Protection system comprise of provision to automatically enable in case if the mobile device is placed in prolonged ideal state with time configured by the user.
- 15
- m) As the system works for device protection high priority interrupts are be assigned for signal processing.
- n) The activated system also sense and act according to preset and user configurations for incoming call, sms, mms, mail, chatting.
- 20
16. The mobile device said in claim 1, comprise of smart radiation pattern optimising system that works utilising artificial intelligence & neural network for sensing & learning the usage scenarios to act accordingly.
- 25
17. The mobile device said in claim 1, where the system is designed with actively tunable electromagnetic screen capable of dynamically controlling and optimising the radiations from antenna in corresponding directions that works based on sensor system parameters, signal quality, operating modes and usage scenarios is either fabricated on printed circuit board(PCB) or incorporated on device casing.
- 30
18. The mobile device said in claim 1, where in the system works with devices comprising of mobile cell phone, cordless phones, walky talkie, laptops, satellite phones, gaming devices, IP phones with form factor of the device selected form group consisting of bar, slate, flip, slider, swivel, flexible, watch, transparent, tablet and mixed type.
- 35
19. The mobile device said in claim 1, where the system works with devices that are with or without, one or multi SIM provision and virtual SIM.
- 40
20. The system said in claim 1, where the system works with wireless technologies comprising of mobile communication, Bluetooth, Wi-Fi, WiMax, ZigBee communication systems with modes of the device in master/slave architecture, infrastructure, peer to peer or one to one, adhoc, wireless mesh network. The system works with communication systems ranging from short to intermediate to long range.
- 45

FIGURE. 1

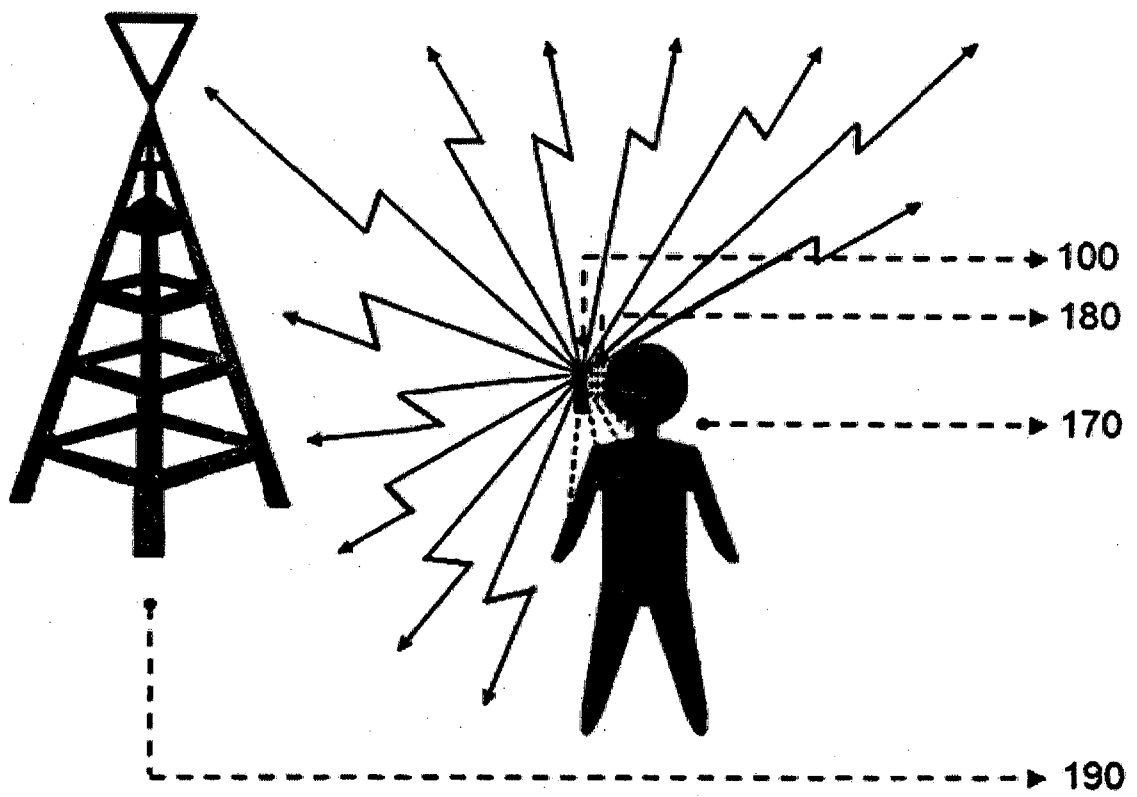
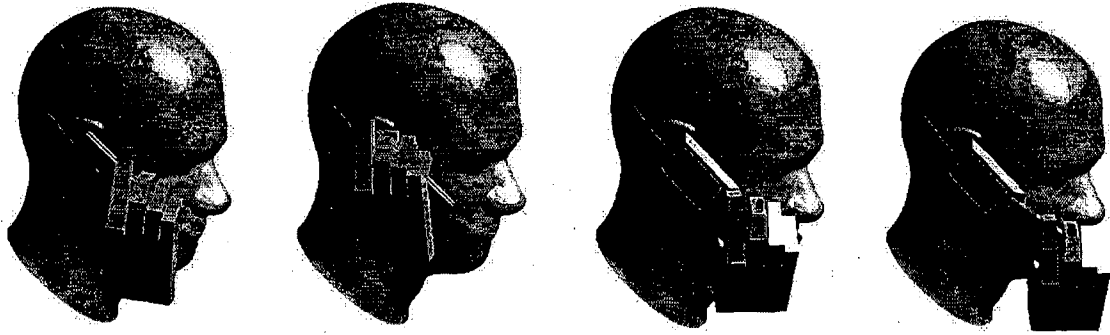

FIGURE. 2

VARIOUS MODELS OF MOBILE DEVICE AND ITS HANDLING POSITION



MOBILE DEVICE



ORIENTATION

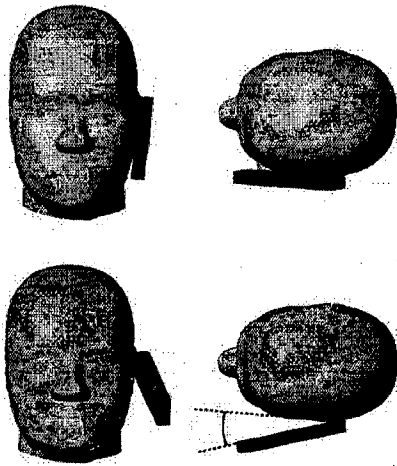

HEAD FORNT VIEW



HEAD TOP VIEW

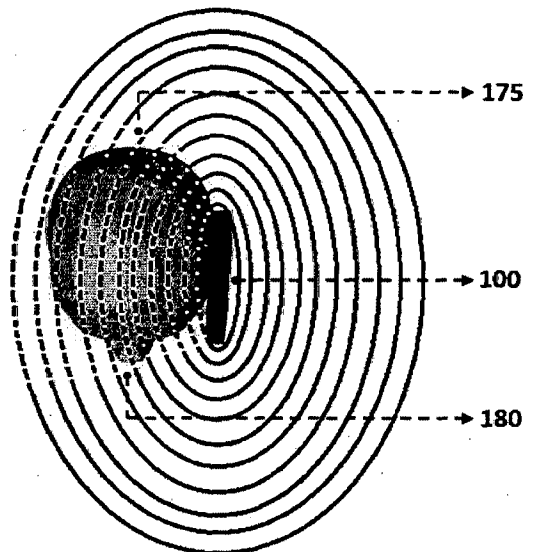
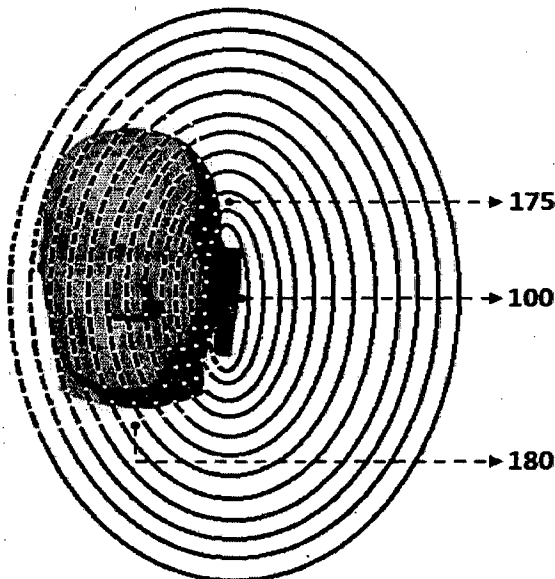
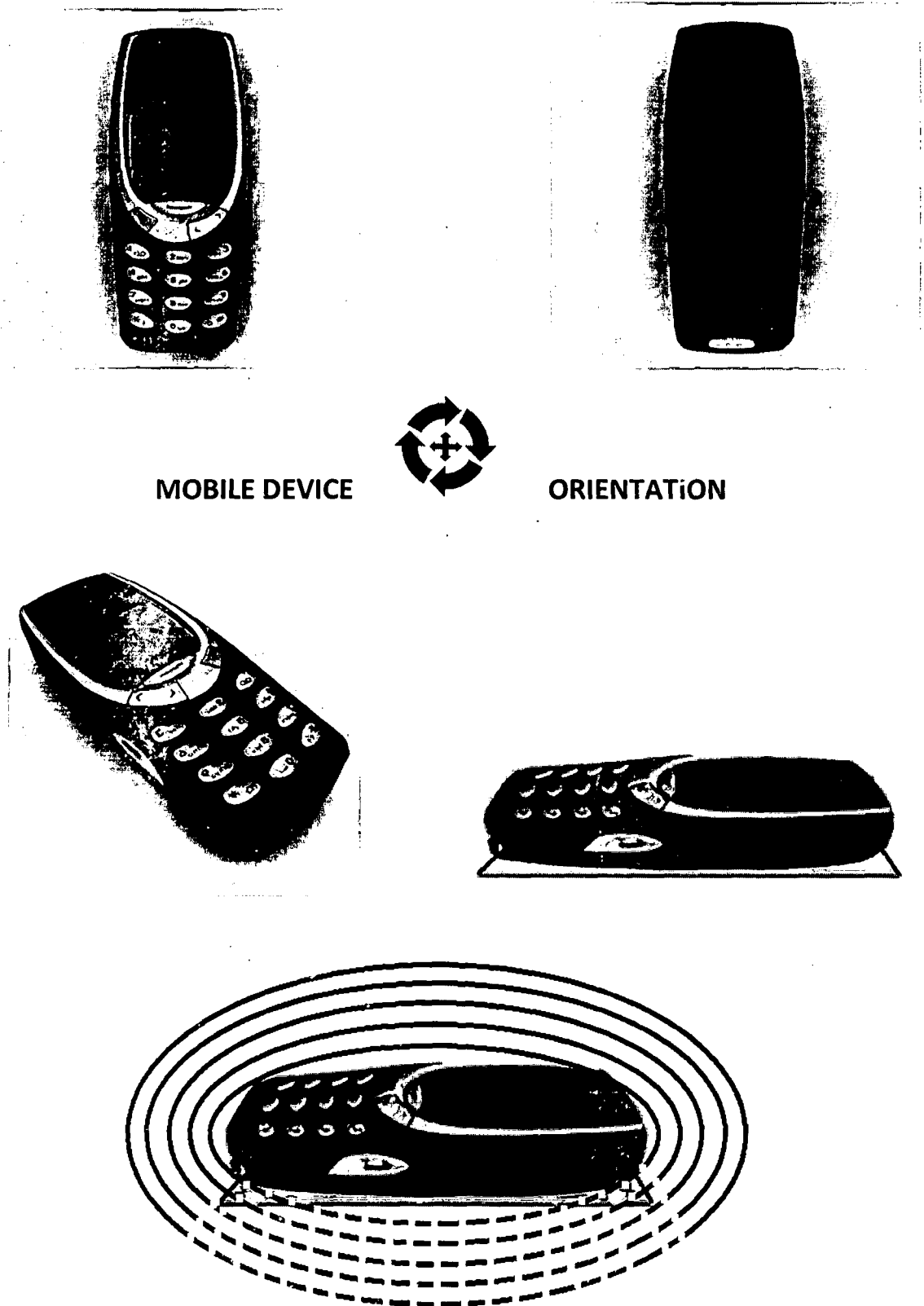

FIGURE 3

MOBILE DEVICE ON VARIOUS USAGE POSITIONS AND PLATFORMS



MOBILE DEVICE



ORIENTATION

FIGURE 4
BLOCK DIAGRAM:
Wireless Mobile Device

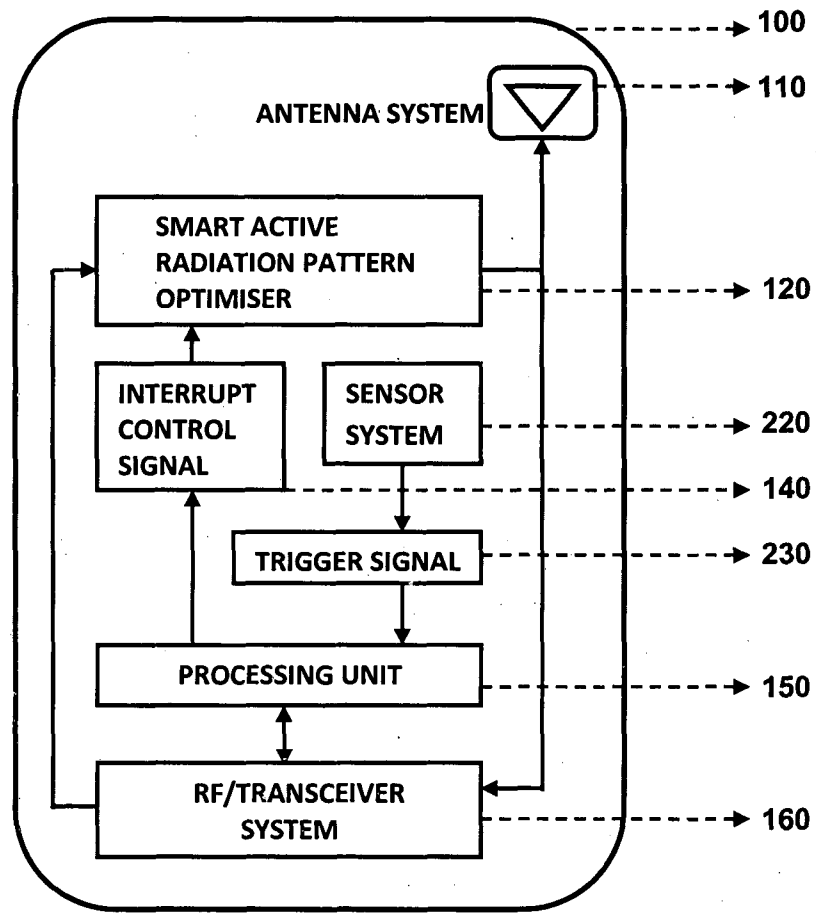

FIGURE 5

FLOW CHART:

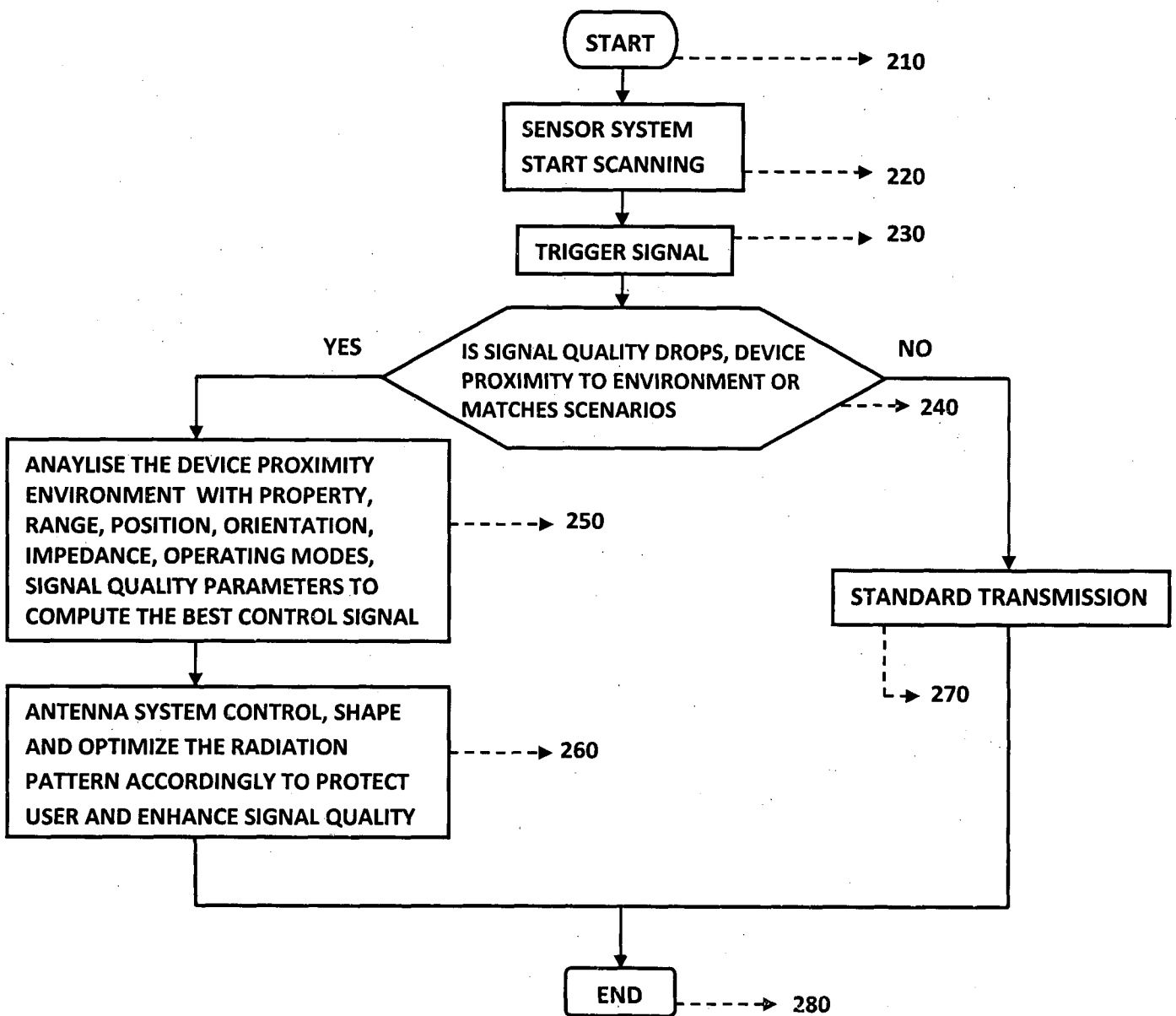

FIGURE. 6

MODEL OF PROXIMITY SENSOR SYSTEM SENSING PROXIMITY ENVIRONMENT AND USER

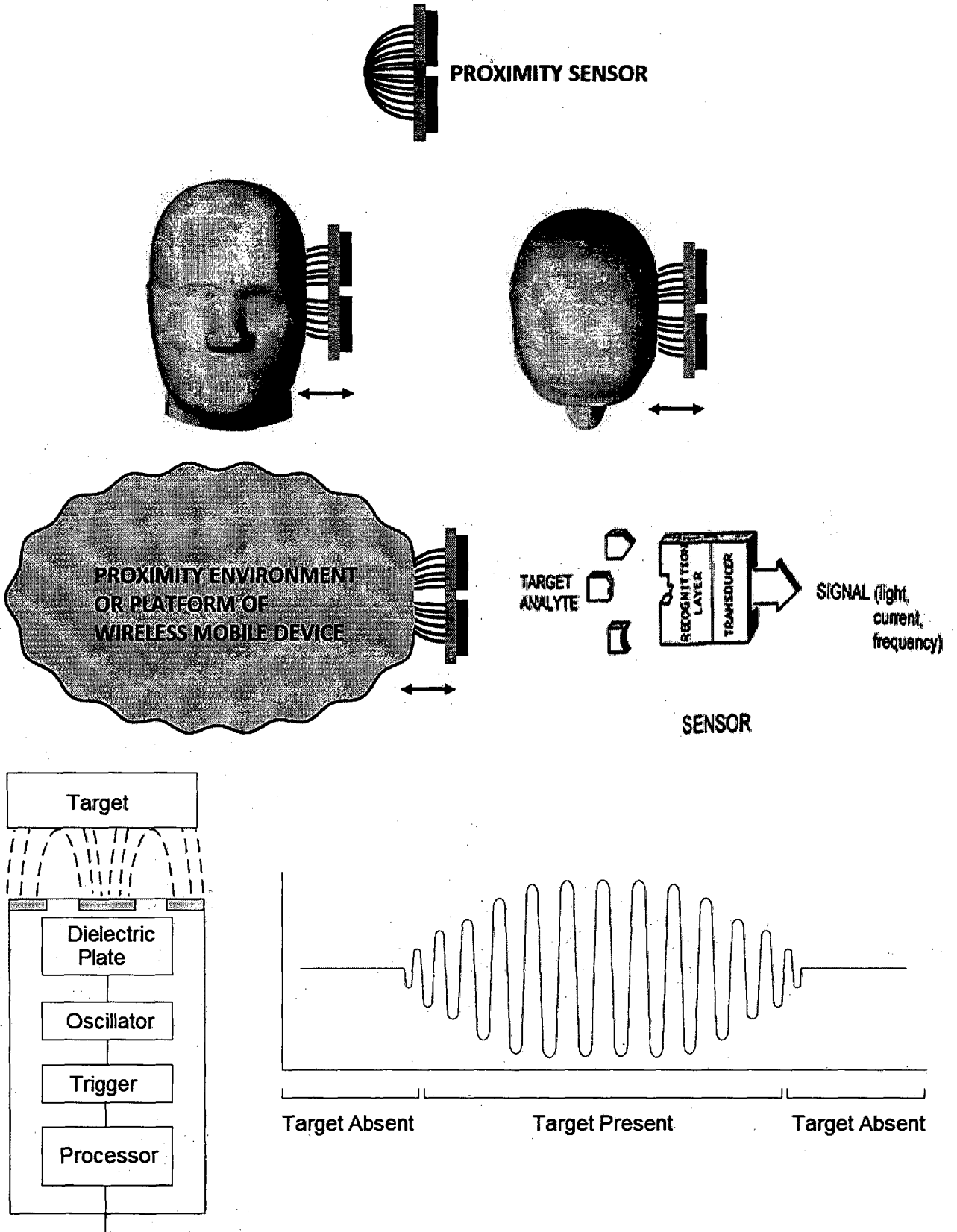

FIGURE. 7

MODEL OF 2x2 and 4x4 MIMO ANTENNA ARRAYS WITH PROXIMITY AND ORIENTATION SENSORS

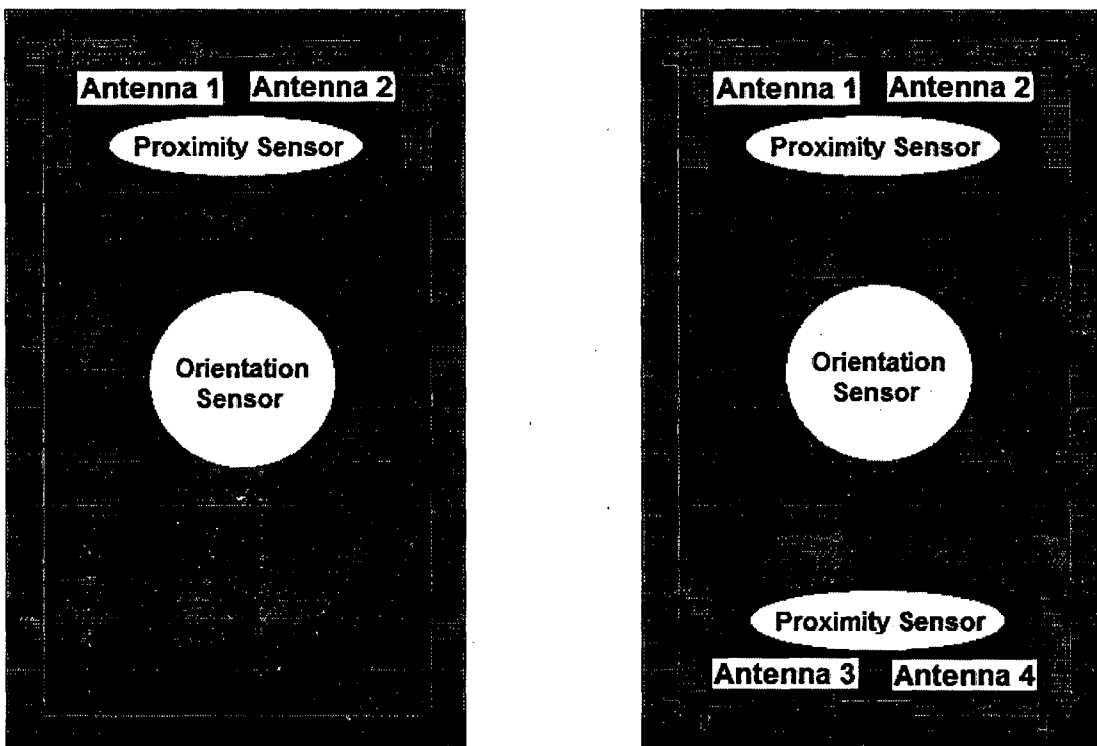
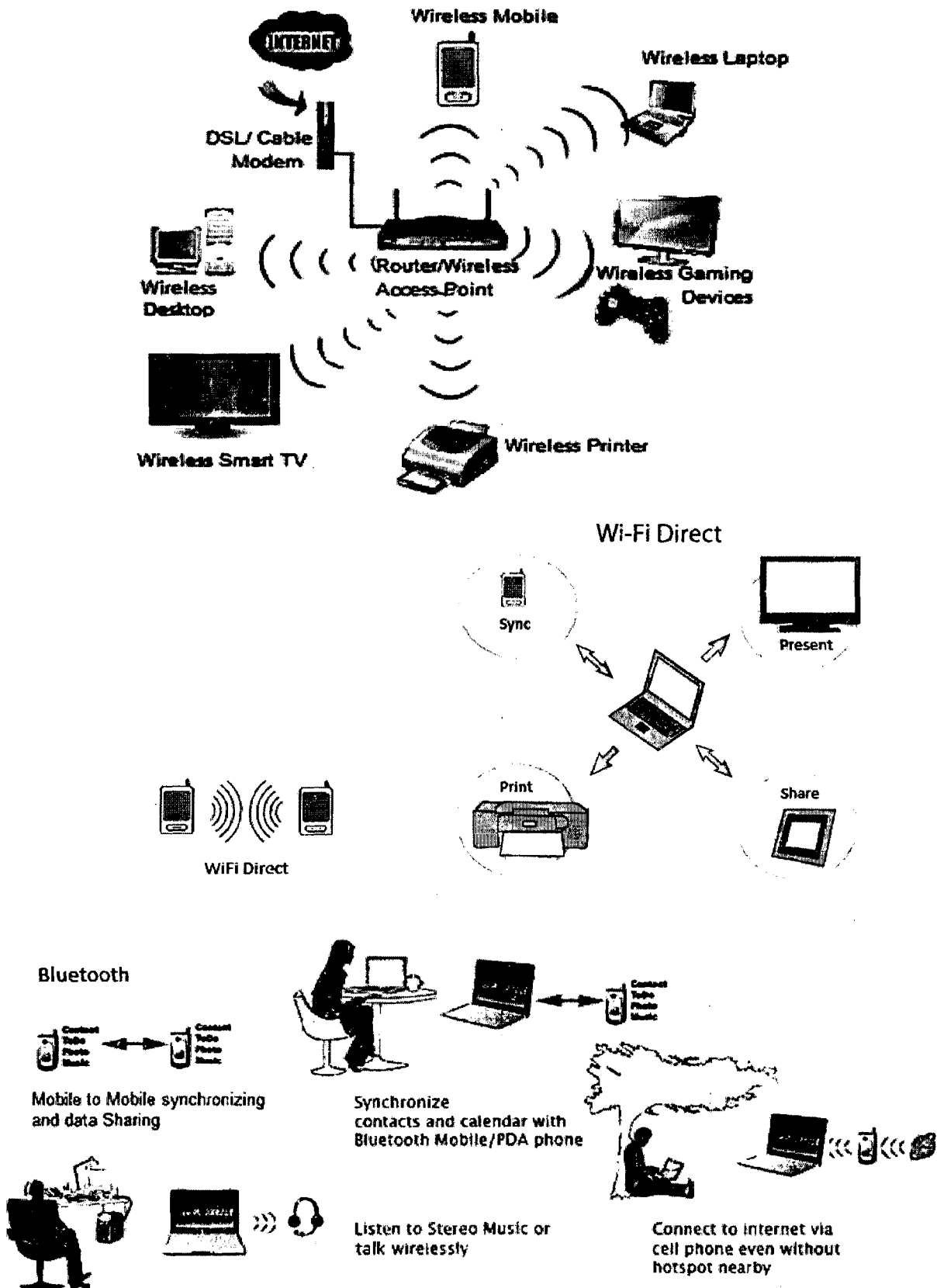

FIGURE. 8



[Wi-Fi is a registered trademark of Wi-Fi alliance and Bluetooth is a registered trademark of Bluetooth SIG Inc]

INTERNATIONAL SEARCH REPORT

International application No.

PCT/IN2012/000439

A. CLASSIFICATION OF SUBJECT MATTER

H01Q 3/00 (2006.01) i

According to International Patent Classification (IPC) or to both national classification and IPC

B. FIELDS SEARCHED

Minimum documentation searched (classification system followed by classification symbols)

IPC: H01Q, H04W, H04L, H04B, H04M

Documentation searched other than minimum documentation to the extent that such documents are included in the fields searched

Electronic data base consulted during the international search (name of data base and, where practicable, search terms used)

WPI, EPODOC, CNKI, CNPAT: antenna, direction, radiation, SAR, sensor, signal, environment, parameter, body, adjust, mobile

C. DOCUMENTS CONSIDERED TO BE RELEVANT

Category*	Citation of document, with indication, where appropriate, of the relevant passages	Relevant to claim No.
A	CN 1250234 A (PHILIPS ELECTRONICS N.V.) 12 Apr. 2000(12.04.2000) description, page 3, line 15 to page 4, line 4	1-20
A	CN 1889590 A (HU, Shu Xin) 03 Jan. 2007(03.01.2007) the whole document	1-20
A	WO 2010/138453 A2 (SKYCROSS, INC.) 02 Dec. 2010(02.12.2010) the whole document	1-20

Further documents are listed in the continuation of Box C.

See patent family annex.

<p>* Special categories of cited documents:</p> <p>“A” document defining the general state of the art which is not considered to be of particular relevance</p> <p>“E” earlier application or patent but published on or after the international filing date</p> <p>“L” document which may throw doubts on priority claim (S) or which is cited to establish the publication date of another citation or other special reason (as specified)</p> <p>“O” document referring to an oral disclosure, use, exhibition or other means</p> <p>“P” document published prior to the international filing date but later than the priority date claimed</p>	<p>“T” later document published after the international filing date or priority date and not in conflict with the application but cited to understand the principle or theory underlying the invention</p> <p>“X” document of particular relevance; the claimed invention cannot be considered novel or cannot be considered to involve an inventive step when the document is taken alone</p> <p>“Y” document of particular relevance; the claimed invention cannot be considered to involve an inventive step when the document is combined with one or more other such documents, such combination being obvious to a person skilled in the art</p> <p>“&” document member of the same patent family</p>
--	---

Date of the actual completion of the international search
30 Oct. 2012(30.10.2012)

Date of mailing of the international search report
29 Nov. 2012 (29.11.2012)

Name and mailing address of the ISA/CN
The State Intellectual Property Office, the P.R.China
6 Xitucheng Rd., Jimen Bridge, Haidian District, Beijing, China
100088
Facsimile No. 86-10-62019451

Authorized officer
ZHUANG, Yong
Telephone No. (86-10)62413981

INTERNATIONAL SEARCH REPORT
Information on patent family members

International application No.
PCT/IN2012/000439

Patent Documents referred in the Report	Publication Date	Patent Family	Publication Date
CN 1250234 A	12.04.2000	EP 0977304 A1	02.02.2000
		JP 2000124828 A	28.04.2000
		KR 20000011967 A	25.02.2000
		TW 412896 A	21.11.2000
		SG 85124 A1	19.12.2001
		US 6456856 B1	24.09.2002
CN 1889590 A	03.01.2007	NONE	
WO 2010/138453 A2	02.12.2010	KR 20120015352 A	21.02.2012