



- (51) **International Patent Classification:**
H04W 4/029 (2018.01) G06K 19/07 (2006.01)
H04W 4/80 (2018.01)
- (21) **International Application Number:**
PCT/US2019/055272
- (22) **International Filing Date:**
08 October 2019 (08.10.2019)
- (25) **Filing Language:** English
- (26) **Publication Language:** English
- (30) **Priority Data:**
62/742,935 09 October 2018 (09.10.2018) US
- (71) **Applicant: REELABLES, INC.** [US/US]; 814 Mission St., 6th Fl., San Francisco, California 94103 (US).
- (72) **Inventor: KREJCAREK, Brian Grant;** 6025 SW Taylor St., Portland, Oregon 97221 (US).
- (74) **Agent: KAIHANI, Saleh;** Cognition IP, P.C., 201 Mission Street, Suite 1200, San Francisco, California 94105 (US).

(81) **Designated States** (unless otherwise indicated, for every kind of national protection available): AE, AG, AL, AM, AO, AT, AU, AZ, BA, BB, BG, BH, BN, BR, BW, BY, BZ, CA, CH, CL, CN, CO, CR, CU, CZ, DE, DJ, DK, DM, DO, DZ, EC, EE, EG, ES, FI, GB, GD, GE, GH, GM, GT, HN, HR, HU, ID, IL, IN, IR, IS, JO, JP, KE, KG, KH, KN, KP, KR, KW, KZ, LA, LC, LK, LR, LS, LU, LY, MA, MD, ME, MG, MK, MN, MW, MX, MY, MZ, NA, NG, NI, NO, NZ, OM, PA, PE, PG, PH, PL, PT, QA, RO, RS, RU, RW, SA, SC, SD, SE, SG, SK, SL, SM, ST, SV, SY, TH, TJ, TM, TN, TR, TT, TZ, UA, UG, US, UZ, VC, VN, ZA, ZM, ZW.

(84) **Designated States** (unless otherwise indicated, for every kind of regional protection available): ARIPO (BW, GH, GM, KE, LR, LS, MW, MZ, NA, RW, SD, SL, ST, SZ, TZ, UG, ZM, ZW), Eurasian (AM, AZ, BY, KG, KZ, RU, TJ, TM), European (AL, AT, BE, BG, CH, CY, CZ, DE, DK, EE, ES, FI, FR, GB, GR, HR, HU, IE, IS, IT, LT, LU, LV, MC, MK, MT, NL, NO, PL, PT, RO, RS, SE, SI, SK, SM, TR), OAPI (BF, BJ, CF, CG, CI, CM, GA, GN, GQ, GW, KM, ML, MR, NE, SN, TD, TG).

(54) **Title:** LOW-POWER ELECTRONIC TAPE FOR TRACKING ITEMS

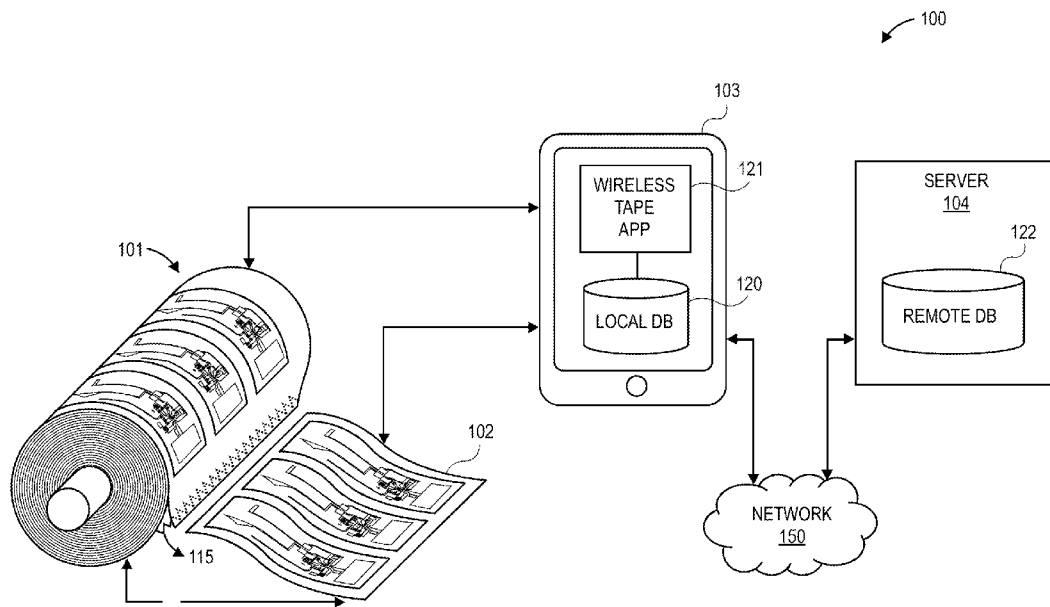

FIG. 1A

(57) **Abstract:** A wireless communication tape, dispenser of the same and methods of usage of the wireless tape and the dispenser in asset tracking applications are disclosed. The wireless communication tape can be manufactured in an ultrathin form factor by laminating a stack of layers to impart functionality to the wireless communication tape. Methods of use and operation of the wireless communication tape are disclosed to save battery resources of the communication tape.



Declarations under Rule 4.17:

- *as to applicant's entitlement to apply for and be granted a patent (Rule 4.17(ii))*
- *as to the applicant's entitlement to claim the priority of the earlier application (Rule 4.17(iii))*
- *of inventorship (Rule 4.17(iv))*

Published:

- *with international search report (Art. 21(3))*

LOW-POWER ELECTRONIC TAPE FOR TRACKING ITEMS

CROSS-REFERENCE TO RELATED APPLICATIONS

[0001] This application claims the benefit of priority of U.S. Provisional Application No. 62/742,935 filed on October 9, 2018 entitled “LOW-POWER ELECTRONIC TAPE FOR TRACKING ITEMS,” content of which is incorporated herein by reference in its entirety and should be considered a part of this specification.

BACKGROUND

Field

[0002] This invention relates generally to the field of wireless communication and more particularly to ultrathin Bluetooth labels used for asset tracking.

Description of the Related Art

[0003] Ability to track objects can have many personal and commercial uses. For example, nearly every business that maintains inventory can use an improved system to track objects within its inventory. Many service businesses can also benefit from a robust object tracking system. Plumbers, electricians and IT professionals carry tools from a base-station to a jobsite. Often the jobsite can be a considerable distance away from the base-station. Forgetting items either at the jobsite or at the base-station can be costly in terms of replacement tools, parts and loss of productivity. The same issues can be present in daily lives of individuals when needed items are left behind. For example, a traveler forgetting to take her passport to the airport, or a student forgetting to take homework to school, or a new mother forgetting to take supplies for a new born outside her home are examples of situations when forgetting items can inconvenience lives and cause loss of money and time. In other situations, forgetting some items can have more severe consequences. For example, a segment of the population, such as patients with diabetes and heart problems, need to remember to have life-saving medicine with them at all times.

[0004] Modern approaches to reminding individuals to take important items with them have included reliance on electronic note taking software designed to keep lists. These solutions often lack the automation and connectivity to make them effective. For example, a tradesman can make a checklist of items to take on a jobsite, but in some days when he is rushed, he may forget to consult the checklist and items can be left behind. Timers and alarms associated with these

programs can also be ineffective because the software is not connected to the items that are to be tracked and software has no knowledge of the whereabouts of the item in relation to the individual.

[0005] Other approaches include use of products, termed “trackers.” Trackers can be fairly expensive items and can come in formfactors that limit their application for tracking objects. For example, they can be in the form of a key-ring or similar devices that can be affixed to an item of interest. For some items, such as medicine bottles, passports or some tools, the trackers’ shape and formfactor prevent reliable attachment to an item of interest. Trackers can include a speaker device and can pair with the user’s smart phone. If the user realizes the tracker-affixed item is lost, the user can trigger the tracker to play an audible sound or alarm to assist the user in finding the item. These solutions also do not improve the situation when the user has left the area where the object was left behind, and the user has to make a return trip to retrieve the item.

[0006] Object tracking can also be performed by using radio frequency identification (RFID) technology, where an RFID label can be affixed to an item of interest and an RFID reader can be used to detect the RFID label. However, these solutions require using specialized and often expensive RFID readers to engage and interact with RFID labels that are attached or affixed to an item of interest, especially in the case of ultrathin RFID labels. Furthermore, object tracking solutions based on passive RFID labels can still rely on human intervention to bring the labels within the range of an RFID reader to enable scanning and tracking of the label. As a result, the ultrathin passive RFIDs can have limited application in object tracking, where the user is to be reminded of the object. In the case of active RFID labels, the bulk of the internal battery and other components and their general formfactor can make them poor candidates for object tracking in the case of many important objects of interest.

[0007] Consequently, there is a need for an object tracking system that connects a user’s existing devices (such as her smart phone or tablet) to the objects that the user needs to track. If smart labels are used, they need to be in a formfactor that can easily be affixed to a multitude of objects. Furthermore, the software component of the object tracking system needs to generate reminders and alerts based on the characteristics of the object and the context of the activities and requirements of the user of the object tracking system.

SUMMARY

[0008] In one aspect, a wireless tape is disclosed. The wireless tape includes: a polyester substrate; an interconnect layer coated on the polyester substrate and patterned to electrically couple a plurality of electrical circuits, wherein the electrical circuits are formed and/or bonded on the interconnect layer, and comprise a Bluetooth processor, a Bluetooth communication circuit

configured to broadcast beacons at a broadcast frequency, and an energy harvesting circuit; a photovoltaic layer coupled to the energy harvesting circuit, wherein the photovoltaic layer and the energy harvesting circuit are configured to generate an electrical signal from converting light to the electrical signal; and a battery comprising a cathode and anode layer and a battery pouch disposed on the interconnect layer, wherein the interconnect layer comprises the cathode layer, and wherein the Bluetooth processor is configured to: receive the electrical signal; determine a rate of change of the electrical signal; and modulate the broadcast frequency, at least in part, based on the determined rate of change of the electrical signal.

[0009] In some embodiments, the Bluetooth processor is further configured to: select a sequence of broadcasting signals, comprising a predetermined number of broadcasting signals; modify the broadcasting signals in the sequence based on a predetermined modification algorithm; and signal the Bluetooth communication circuit to transmit the sequence of the modified broadcasting signals to a smart device.

[0010] In one embodiment, the smart device receives and routes the sequence of modified broadcasting signals to a wireless tape application running on the smart device and the wireless tape application reconstructs unmodified broadcasting signals from the received modified broadcasting signals, based on the predetermined modification algorithm.

[0011] In another embodiment, the predetermined modification algorithm comprises modifying a MAC address and/or a UUID in the broadcasting signals.

[0012] In some embodiments, the wireless tape, further includes: a coil antenna formed and/or disposed on the interconnect layer and tuned to resonate at a frequency generated by a transceiver of a smart device; and wherein the coil antenna is electrically coupled to a GPIO port of the Bluetooth processor, wherein the coil antenna is configured to receive RF energy field generated by the transceiver and convert the RF energy to an AC signal, and transmit the AC signal the GPIO port of the Bluetooth processor waking up the Bluetooth processor, and wherein the Bluetooth processor begins transmitting a wireless beacon comprising a startup sequence, having a predefined power level and an identifier of the Bluetooth processor and the Bluetooth communication circuit.

[0013] In some embodiments, the Bluetooth processor further comprises an ADC configured to receive voltages from a conductive surface of the wireless tape and the Bluetooth processor is further configured to determine a rate of change of the voltages from the conductive surface and modulate the broadcast frequency, at least in part, based on the determined rate of change of the voltages from the conductive plane.

[0014] In another embodiment, the Bluetooth processor further comprises an ADC configured to receive voltages from a pair of parallel conductive surfaces of the wireless tape and the Bluetooth processor is further configured to modulate the broadcast frequency, at least partly, based on difference between voltages received from the parallel conductive surfaces.

[0015] In one embodiment, the wireless tape further includes a first conductive plane and a second conductive plane formed on the interconnect layer and forming a part of an edge of the wireless tape, wherein the interconnect layer is further patterned to electrically couple the first conductive plane to a terminal of the battery and the second conductive plane to a GPIO port of the Bluetooth processor.

[0016] In another embodiment, the wireless tape, further includes a first conductive plane and a second conductive plane formed on opposite edges of the wireless tape and on an external surface of the wireless tape, wherein the interconnect layer is further patterned to connect the first and second conductive planes to terminals of a GPIO port of the Bluetooth processor, and wherein the first and second conductive planes comprise an electrically conductive adhesive layer.

[0017] In some embodiments, a dispenser is configured to dispense the wireless tape.

[0018] In another aspect, a method is disclosed. The method includes: providing a polyester substrate; coating an interconnect layer on the polyester substrate and patterning the interconnect layer to electrically couple a plurality of electrical circuits, wherein the electrical circuits are formed and/or bonded on the interconnect layer, and comprise a Bluetooth processor, a Bluetooth communication circuit configured to broadcast beacons at a broadcast frequency, and an energy harvesting circuit; providing a photovoltaic layer coupled to the energy harvesting circuit, wherein the photovoltaic layer and the energy harvesting circuit are configured to generate an electrical signal from converting light to the electrical signal; and forming a layered battery comprising a cathode and anode layer and a battery pouch disposed on the interconnect layer, wherein the interconnect layer comprises the cathode layer, and wherein the Bluetooth processor is configured to: receive the electrical signal; determine a rate of change of the electrical signal; and modulate the broadcast frequency, at least in part, based on the determined rate of change of the electrical signal.

[0019] In some embodiments, the Bluetooth processor is further configured to: select a sequence of broadcasting signals, comprising a predetermined number of broadcasting signals; modify the broadcasting signals in the sequence based on a predetermined modification algorithm; and signal the Bluetooth communication circuit to transmit the sequence of the modified broadcasting signals to a smart device.

[0020] In another embodiment, the smart device receives and routes the sequence of modified broadcasting signals to a wireless tape application running on the smart device and the wireless tape application reconstructs unmodified broadcasting signals from the received modified broadcasting signals, based on the predetermined modification algorithm.

[0021] In one embodiment, the predetermined modification algorithm comprises modifying a MAC address and/or a UUID in the broadcasting signals.

[0022] In some embodiments, the method, further includes: forming and/or disposing a coil antenna on the interconnect layer; tuning the coil antenna to resonate at a frequency generated by a transceiver of a smart device; and electrically coupling the coil antenna, and a GPIO port of the Bluetooth processor, wherein the coil antenna is configured to receive RF energy field generated by the transceiver and convert the RF energy to an AC signal, and transmit the AC signal to the GPIO port of the Bluetooth processor waking up the Bluetooth processor, and wherein the Bluetooth processor begins transmitting a wireless beacon comprising a startup sequence, having a predefined power level and an identifier of the Bluetooth processor and the Bluetooth communication circuit.

[0023] In one embodiment, the Bluetooth processor further comprises an ADC configured to receive voltages from a conductive surface of the wireless tape and the Bluetooth processor is further configured to determine a rate of change of the voltages from the conductive surface and modulate the broadcast frequency, at least in part, based on the determined rate of change of the voltages from the conductive plane.

[0024] In another embodiment, the Bluetooth processor further comprises an ADC configured to receive voltages from a pair of parallel conductive surfaces of the wireless tape and the Bluetooth processor is further configured to modulate the broadcast frequency, at least partly, based on difference between voltages received from the parallel conductive surfaces.

[0025] In some embodiments, the method further includes forming a first conductive plane and a second conductive plane on the interconnect layer and as a part of an edge of the wireless tape; and further patterning the interconnect layer to electrically couple the first conductive plane to a terminal of the battery and the second conductive plane to a GPIO port of the Bluetooth processor.

[0026] In another embodiment, the method, further includes forming a first conductive plane and a second conductive plane on opposite edges of the wireless tape and on an external surface of the wireless tape; and further patterning the interconnect layer to connect the first and second conductive planes to terminals of a GPIO port of the Bluetooth processor, and wherein the first and second conductive planes comprise an electrically conductive adhesive layer.

[0027] In another aspect, an object tracking system is disclosed. The object tracking system, includes: the wireless tape; a wireless tape application, comprising program instructions to execute the wireless tape application on a computer device, and wherein the wireless tape application is configured to: receive the broadcast beacons, comprising a unique identifier of the wireless tape; query one or more databases to determine if the wireless tape is associated with a user and/or an item; receive an input from the user comprising a description of an item to be tracked; update the one or more databases with an association of the user and/or the item to be tracked and the unique identifier; and monitor the broadcast beacons and alert the user if the broadcast beacons are not received after a threshold period of time.

BRIEF DESCRIPTION OF THE DRAWINGS

[0028] These drawings and the associated description herein are provided to illustrate specific embodiments of the invention and are not intended to be limiting.

[0029] FIG. 1A illustrates an object tracking system according to an embodiment.

[0030] FIG. 1B is a block diagram illustrating more details of a dispenser and a wireless tape, used in the object tracking system.

[0031] FIG. 2A illustrates an exemplary method of dispensing the wireless tape from the dispenser for tracking objects.

[0032] FIG. 2B illustrates an exemplary method of using the object tracking system and determining whether to present an alert.

[0033] FIG. 3 illustrates some layers and arrangements of the layers in an example wireless tape according to an embodiment, where a layered battery structure is used.

[0034] FIG. 4 illustrates a diagram of a wireless tape, which can be paired to a smart device, without using a dedicated NFC pairing chip.

[0035] FIG. 5 illustrates a method of Bluetooth pairing of an NFC-enabled wireless tape with a smart device.

[0036] FIG. 6 illustrates a diagram of a communication protocol between a wireless tape and a smart device, which can enhance the background processes of the smart device in relation to the processing of the signals received from the wireless tape.

[0037] FIG. 7 illustrates a method of enhancing the background processes of a smart device in relation to receiving broadcasting signals from the wireless tape.

[0038] FIG. 8 illustrates an embodiment of the wireless tape, where fluctuations in light levels can be used to modulate the frequency of broadcasting beacons.

[0039] FIG. 9 illustrates a method of using fluctuations in light level to modulate the frequency of a broadcasting beacon.

[0040] FIG. 10 illustrates diagrams of various embodiments to maintain the wireless tape in a low-power state when in storage or before deployment by a user of the object tacking system.

DETAILED DESCRIPTION

[0041] The following detailed description of certain embodiments presents various descriptions of specific embodiments of the invention. However, the invention can be embodied in a multitude of different ways as defined and covered by the claims. In this description, reference is made to the drawings where like reference numerals may indicate identical or functionally similar elements.

[0042] Unless defined otherwise, all terms used herein have the same meaning as are commonly understood by one of skill in the art to which this invention belongs. All patents, patent applications and publications referred to throughout the disclosure herein are incorporated by reference in their entirety. In the event that there is a plurality of definitions for a term herein, those in this section prevail. When the terms “one”, “a” or “an” are used in the disclosure, they mean “at least one” or “one or more”, unless otherwise indicated.

[0043] *Object tracking system 100*

[0044] FIG. 1A illustrates an object tracking system 100 according to an embodiment. A tape dispenser 101 can be used to dispense, a wireless tape 102 from a reel of rolled up wireless tape 102. The dispenser 101 can include a cutting means 115 for detaching wireless tape 102 from its reel. The wireless tape 102 can include an adhesive layer allowing it to be affixed to various objects for tracking.

[0045] Wireless tape 102 is capable of wireless communication with a smart device 103. The smart device 103 may be any kind of computer system capable of sending and receiving wireless communication to and from the wireless tape 102. Examples, include smart phones, tablets, smart glasses, smart watches, laptops, desktops, personal digital assistant (PDA) devices and others. In one embodiment, a wireless tape application 121 may run on the smart device 103 to manage the operations of one or more wireless tapes 102. The wireless tape application 121 can include program instructions to wirelessly communicate with the wireless tapes 102 and a server 104 via a wired or wireless connection with the network 150. The network 150 can be a local-area network, intranet, wide-area network, internet, the Internet, wireless networks, wired networks, a Wi-Fi, Bluetooth, cellular network or other networks. The server 104 may be local to the wireless tape 102 and/or the smart device 103 or it may be at a remote location.

[0046] The wireless tape application 121 may maintain and/or manage a local database 120 on the smart device 103. The local database 120 can store various information related to the tracking and management of the wireless tapes 102, such as an identifier for each wireless tape 102, name of an associated item to which the wireless tape is affixed, description and/or images of the item, historical tracking data, an identifier of the owner/custodian of the item and other information as may be desired to be stored in relation to a tracked object. The data stored in local database 120 can additionally, instead or partially be stored in a remote database 122 at the server 104. The server 104 may include the remote database 122, which includes information about additional wireless tapes 102 that may be associated with a user and also other users of wireless tapes 102. Although illustrated as a single server 104, the server 104 may be implemented as a plurality of networked servers.

[0047] FIG. 1B is a block diagram illustrating more details of the dispenser 101 and the wireless tape 102. The dispenser 101 may include a beacon 110, comprising a wireless communication system, and a cutting means 115 for detaching pieces of wireless tape 102 from a roll of them. The beacon 110 can be any wireless communication device, capable of transmitting and receiving wireless communication signals to and from the smart device 103. As described earlier, the dispenser 101 can include a cutting means 115 configured to detach wireless tapes 102 during dispensing process. In other embodiments, the dispenser 101 can be a housing enclosing a stack of wireless tapes 102 that are folded in a zig-zag pattern on top of one another. A small slit in the housing allows at least one wireless tape 102 to protrude through the slit, giving a user an ability to tear one wireless tape 102 from the rest of the stack. The wireless tapes 102 may be separated by perforation along which a user may tear and separate one wireless tape 102 from the rest. Alternatively, or in addition to perforation, a cutting means at the slit can facilitate separating a wireless tape 102 from the rest.

[0048] The wireless tape 102 may comprise a plurality of electronics on a flexible and ultrathin substrate 116. In some embodiments, the electronics in the wireless tape 102 can include a wireless communication circuit 111, a processor 112, timer 113, battery 114, and memory module 117, etched, fabricated, bonded or otherwise formed on the substrate 116 and connected through an interconnect layer 118. The interconnect layer 118 can be any electrically conductive material, including aluminum, copper, gold, silver and others. While the circuitry in the wireless tape 102 are shown as discrete components, the persons of ordinary skill in the art can appreciate that these components can be combined in single or multiple chips, depending according to various implementation of the disclosed embodiments. For example, when a Bluetooth wireless communication circuit is used to implement the wireless tape 102, the processor 112 can include

Bluetooth wireless communication circuitry, and timing circuits, as well as volatile and non-volatile memory to carry out the operations of the wireless tape 102. Alternatively, some components may be integrated, while others can remain as separate components.

[0049] *Using the object tracking system 100*

[0050] FIG. 2A illustrates an exemplary method 200 of dispensing the wireless tape 102 from dispenser 101 for tracking objects. The wireless tape 102 can be dispensed from a roll of wireless tapes 102 and subsequently attached to an item to be tracked. In step 201, the wireless tape 102 is dispensed from the dispenser 101 and simultaneously activated in a single action. Activation can refer to waking up the processor 112 to send/receive wireless signals, beacons, packets or other wireless messages, using the wireless communication circuit 111. In step 202, the wireless tape 102 may transmit a wireless signal to the smart device 103. The wireless signal may be transmitted at predetermined intervals based on signal from the timer 113, or may be transmitted based on detected changes in the environment such as through electrostatic detection or other mechanisms like ambient light sensing, accelerometer or other methods, as described herein.

[0051] The wireless signal transmitted from the wireless tape 102 may include a unique identifier that is encoded in the memory module 117 of the processor 112, where the identifier is unique among all the wireless tape devices. In step 203, the smart device 103 may receive the wireless signal from the wireless tape 102. In step 204, configuration and setup of the wireless tape 102 may be performed on the smart device 103. The configuration and setup of a wireless tape 102 can include, which can include registering an item to be tracked and associating the item with a unique identifier of the wireless tape 102 and recording the registration and association in one or more local or remote databases, including local database 120 and the remote database 122. The smart device 103 may check for the identifier in the local database 120. If the identifier is located in the local database 120, the smart device 103 may display some or all of the stored information about the wireless tape device and its associated item. Otherwise, the smart device 103 may transmit a request to the server 104 to query the remote database 122 using the identifier. If the identifier is found in the remote database 122, then the information about the wireless tape device is retrieved from the remote database 122 and transmitted from the server 104 to the smart device 103 where the information may be displayed. For example, the smart device 103 may display an indication of the owner of the wireless tape 102. Otherwise, if the wireless tape 102 is not found in the local database 120 nor the remote database 122, then this can indicate that the wireless tape 102 is unassociated with any smart device 103 and can be paired to the smart device 103. The smart device 103 may prompt the user to pair the wireless tape 102 and thereby claim ownership of it. The smart device 103 may display on its screen user interface elements for entering

information about the item that the wireless tape 102 is attached to and/or is going to be tracking. The smart device 103 can gather information, such as a name and description of the item. The gathered item information can include text entry, photo of the item, video, voice memo and/or any other data associated with the owner/tracker of the item and/or the item. The gathered item and/or owner data can be stored in the local database 120 and/or in the remote database 122 along with the identifier of the paired wireless tape 102.

[0052] FIG. 2B illustrates an exemplary method 220 for using the object tracking system 100. The method 220 involves the dispenser 101, the smart device 103, and the wireless tape 102. In step 221, the dispenser transmits a dispenser beacon, using the wireless circuit 110, to indicate the location of the dispenser and a geofence around that location. The dispenser 110 can be activated and send dispenser beacons by a variety of means, for example, the dispenser 110 may be activated when it first dispenses a wireless tape 102. The geofence may comprise geographic coordinates defining a 2D or 3D area on a map surrounding the location of the dispenser 101. The geofence effectively serves to identify a base area where it may not be necessary to track items (*e.g.*, to determine if they are missing). Depending on the implementation of the object tracking system 100, places, such as homes, base-office, base-warehouse, or other base locations may be considered areas where tracking objects are not needed and therefore various resources of the object tracking system 100 can be conserved. In a base area, items may be naturally stored in different places so that it is not necessary to check for missing items. The dispenser 101 may transmit its beacon rapidly, such as once per second or more in some embodiments. The beacon signal may optionally include coordinates of the boundary of the geofence. In other embodiments, the beacon signal may only include the coordinates of the dispenser, and the smart device may configure and store the appropriate range considered to be within the geofence. In an alternative embodiment, the geofence can be established by signals from an activated wireless tape 102, adhered or placed at a home-base location.

[0053] In step 222, the smart device 103 may monitor for the dispenser 101 beacon. If the dispenser 101 beacon is not received, then the smart device 103 may flag its state as not being at the base (step 224). Otherwise, if the beacon is received by the smart device 103, the smart device 103 may read the coordinates of the geofence (or in some embodiments generate the coordinates of the geofence). The smart device 103 may also identify its own coordinates using location services, such as Global Positioning System (GPS), Global Navigation Satellite System (GNSS), Wi-Fi positioning, or other location services. The smart device 103 may compare its location to the location of the geofence. If the smart device 103 is within the geofence, then the smart device

103 may flag its state as being at base (step 223). Otherwise, the smart device 103 may determine that it is outside the geofence and flag its state as being outside of base (step 224).

[0054] In step 225, when the smart device 103 is in an out-of-base state, the smart device 103 may monitor for beacons from one or more wireless tapes 102, which may have been attached to one or more items of interest by a user of the object tracking system 100 and the carrier of the smart device 103. In step 230, the wireless tapes 102 in the area may transmit their beacons. Those beacons may be received by the smart device 103. When the smart device 103 receives the beacon from the wireless tape, it may read the identifier and retrieve the associated records of that identifier from the local database 120. The smart device 103 may then store an indication in the local database 120 records that the item tracked by the wireless tape 102 is present (step 226). This assumption can be made because the wireless beacons sent by the wireless tape 102 have a short range of, for example, 8-10 feet. The smart device 103 may track the elapsed amount of time since a beacon was last received from each wireless tape 102 by querying its local database 120. When a threshold amount of time has been exceeded since a beacon was last received from a wireless tape 102, then the smart device 103 may mark the associated item in the local database 120 as not present (step 227). The smart device 103 then determines whether to alert (step 228) or not alert (229) the user of the smart device 103 for an item not being present/found. Alerts may be shown by displays on a screen, with sounds, with haptic feedback, or by any other alert mechanism, using the smart device 103.

[0055] The process of alerting or not alerting may be determined according to multiple conditions. In one embodiment, one or more checklists of items may be selected and activated by a user of the smart device 103. The checklists may each include one or more items that should be present with the user. If an item on the checklist is not present at step 227, then an alert may be generated. In other embodiments, an alert may be generated if the user initially had an item with him when he left the geofence at step 224 but, at some point, the smart device 103 detected that the item no longer is with him. This may indicate that a user took an item with him from a base location (such as home or work) and then lost it. Consequently, an alarm can be generated at step 228, so the user can look for the time.

[0056] In other embodiments, the conditions may be received from a user about when to alert about the absence of certain items. For example, configurations may be received from a user that alerts for an item should only be generated on certain days of the week, at certain times of day, during certain weather conditions, or various other conditions. In other embodiments, whether the absence of an item should be alerted may be determined by training a machine learning model. The machine learning model may be trained using data, such as an indication of when a beacon

signal was no longer received (input) and an indication of whether the associated item was actually lost (desired output value). The machine learning model may be trained to trigger an alert when an item is likely to have been actually lost. The machine learning may analyze features related to a beacon signal, such as the associated item, time of day, location, and so on and use that to predict whether an alert should be generated. Machine learning models that may be used herein may include Bayesian classifiers, logistic classifiers, logistic regression, linear regression, neural networks, random forests, support vector machines, and any other machine learning model.

[0057] In some cases, the smart device 103 may not receive a beacon signal from one or more wireless tapes 102 even though they are within range of about 8-10 feet, and they have transmitted the beacon signal. This may be due to RF interference from other devices causing a missed signal. In cases, where a user is about to leave a location, a missed beacon signal from a wireless tape 102, can mistakenly indicate an item is missing. In these scenarios, it is advantageous, if the user can manually trigger the wireless tape 102 to send one or more additional beacons to indicate to the presence of the wireless tape 102 and its associated item to the object tracking system 100. A user may simply tap the wireless tape 102 to trigger an immediate wireless beacon. This may be achieved with a sensitive switch such that when pressure is applied to an external surface of the wireless tape 102, an electrical signal is sent to one or more of the wireless communication circuit 111, the processor 112 and the timer 113 to activate one or more of these components and send a wireless beacon. Alternatively, a piezo electric material may also be included in the wireless tape 102. The piezo electric material can be sensitive to haptic signals, for example from a touch or tap, and can emit a signal when activated. That signal from the piezo electric material may also be used to trigger a wake up of one or more additional components of the wireless tape 102 (e.g., processor 112) to send a wireless beacon to the smart device 103.

[0058] *Wireless tape 102*

[0059] Various techniques and material, described herein, can be used to manufacture the wireless tape 102 in an ultrathin fashion. For example, the inclusion of the battery source in most ultrathin devices can be challenging. In one embodiment, the wireless tape 102 can be manufactured as a laminated structure, where a battery source is integrated in the laminated structure to distribute the battery components between various layers to reduce the overall area consumed by the battery source and to maintain the flexibility of the wireless tape 102.

[0060] FIG. 3 illustrates some layers and arrangements of the layers in an example wireless tape 102 according to an embodiment, where a layered battery structure is used. In the embodiment shown, an anode layer 302 of the battery powering the wireless tape 102 is the bottom layer. In one embodiment, the anode layer 302 may be a graphite coated anode in a reel-to-reel process.

The substrate layer 116 and the components thereon are sandwiched between the anode layer 302 and a photovoltaic layer 310. The photovoltaic layer 310 can be formed from a lattice of an organic photovoltaic (OPV) material or other solar energy harvesting material. The interconnect layer 118 formed on the substrate 116 can function as a cathode of the battery powering the electronics 306 of the wireless tape 102. A battery pouch 308 containing electrochemical components of the battery can be formed on the interconnect 118. The substrate 116 can be an ultrathin and flexible material such as a polyester or Polyethylene terephthalate (PET). The interconnect layer 118 can be coated with a conductive metal, such aluminum. The battery pouch 308 can be manufactured by coating the interconnect 118 in the battery portion by an active lithium compound, such as lithium manganese dioxide. The wireless tape 102 can also include an adhesive layer 304 to allow the wireless tape 102 to be affixed to an item for tracking or other purposes.

[0061] The electronics 306 can include various components depending on the implementation of the wireless tape 102. For example, if the photovoltaic layer 310 is used, the electronics 306 can include circuitry to harvest and utilize light energy absorbed from that layer to power the electronics 306. If manual beacon trigger feature is included, the electronics 306 can include an associated switch and/or piezo electric sensors. The electronics 306 can include the components of the wireless tape 102 as described above. Examples include, the wireless communication circuit 111, the processor 112, the timer 113 and the memory 117. These components can be discrete, separate components or they can be part of an integrated circuit implementing their functionality in one or multiple chips. In some embodiments, as will be described the electronics 306 can include an analog to digital converter (ADC). Additional electrical components 306, depending on the implementation of the wireless tape 102 can include, a near field communication chip (NFC), sensors (*e.g.*, sensors for detecting ambient light, motion, acceleration, temperature, *etc.*). While not shown, the interconnect layer 118 can be patterned in a manner to provide electrical connection and/or isolation between the electrical components 306 of the wireless tape 102. The layers shown are for example purposes only and persons of ordinary skill in the art can envision that the wireless tape 102 may be manufactured with more or fewer layers than those shown.

[0062] *Example dimensions and components of wireless tape 102*

[0063] Embodiments of the wireless tape 102 may be constructed in various ways. One embodiment of the wireless tape 102 is a paper-thin label that comprises ultrathin electronics printed or etched on laminated layers of a polyester film (*e.g.*, PET), as described earlier. In some embodiments, the thickness of the wireless tape 102, including the layers and the electronics therein, depending on the implementation, can range from approximately 1/20th of a millimeter, to half a millimeter. The electronics 306 may be etched or printed into the interconnect layer 118,

or they may be attached or otherwise bonded to the interconnect layer 118, as separate chips or circuits or as various integrated or separate components, depending on the implementation. In some embodiments, the wireless tape 102 is designed to transmit its beacon at intervals using a timer 113 as shown in FIG. 1B. This design may save energy by keeping the electronics 306 on the wireless tape 102, including the processor 112 and wireless communications chip 111, in a lower power or off state until they are awakened at intervals by the timer 113. When the timer 113 signals an active state, the signal is used to turn on or signal the processor 112 to activate and send a wireless beacon. In one embodiment, the wireless beacon is formatted as a standard Bluetooth low energy (BLE) signal and/or an iBeacon. In an embodiment, the timer 113 is a Texas Instruments TPL5110 and draws current of approximately 35 nano amperes (nA) or less. Texas Instruments of Dallas, Texas, can be reached at (972-995-2011). The timer 113 is configured to turn on or signal the processor 112 at intervals, such as every ten seconds. In some embodiments, the timer 113 may be set to activate at a rate between every five to ten seconds, five to fifteen seconds, five to twenty seconds, two to twenty seconds, one to thirty seconds, or one to sixty seconds. In an embodiment, the processor 112 is the Nordic Semiconductor, nRF52810 manufactured by Nordic Semiconductor ASA of Trondheim, Norway (+47 72 89 89 00). As will be described, some embodiments of the wireless tape 102 may send wireless beacons based on sensor data, instead of or in addition to input signal from the timer 113. Consequently, in some embodiments, the timer 113 can be optional.

[0064] To help achieve an ultrathin form factor for the wireless tape 102, one or more of the surface areas of the battery pouch 308, the anode layer 302 or the cathode layer (*e.g.*, some or a portion of the interconnect layer 118) can be used as a wireless communication antenna, instead of a traditional dedicated antenna component (such as a printed antenna). For example, in some embodiments, the surface area of the battery pouch 308 comprises a substantial area within the wireless tape 102 and can function additionally as a wireless antenna component to radiate wireless beacons. When a Nordic nRF52810 or similar processors 112 are used, the wireless balun at the analog output of the processor 112 can be connected to an outside metal foil of the battery pouch 308, or the anode layer 302 or to the interconnect layer 118 and/or a portion thereof, where these components can additionally function as an antenna.

[0065] The wireless tape 102 may be designed with an adhesive layer to attach the wireless tape 102 to a surface of an item of interest to track the item. In one embodiment, As described, the wireless tapes 102, in some embodiments, can be fabricated on a very flexible substrate 116 (*e.g.*, a PET substrate), with a thin, flexible, lithium primary battery source printed or laminated directly

to a flexible coated interconnect layer 118, therein. In one embodiment, the battery may be printed into the interconnect layer 118.

[0066] In one embodiment, the wireless tape 102 may be designed to adhere to a range of surfaces and things. In an embodiment, one or both sides of the wireless tape 102 are coated with an adhesive to allow sticking to other objects. Similar to a piece of common tape, wireless tapes 102 can be manufactured on a roll of substrate and perforated on their edges to delineate each individual wireless tape 102. The wireless tapes 102 can be manufactured with the ability to tape back on itself, forming a loop to securely attach the wireless tape 102 to items, such as cables. Persons of ordinary skill in the art can envision other mechanical form factors for the wireless tape 102 to facilitate adhering the wireless tapes 102 to items of various shapes, sizes and textures.

[0067] *Methods of pairing wireless tape 102 with smart device 103*

[0068] In one embodiment, the wireless communication circuit 111 can be activated and paired with the smart device 103 using near-field-communication (NFC). NFC can be used to wirelessly communicate data stored on ID cards, payment devices, information tags and other memory-embedded devices. In one respect, NFC provides a way of for a communicating device to send short bits of information at close distances without the need for the communicating device to draw power from a battery for sending that information. Instead, an NFC-enabled communicating device relies upon the radio frequency (RF) energy field of a reader device to generate sufficient energy that can be harvested by a silicon-based NFC chip to read/write to a memory device, and then reflect the information stored in the memory back to the reader.

[0069] NFC can be employed to pair NFC-enabled Bluetooth devices such as internet of things (IOT) appliances, wearables or other devices with user accounts on mobile phones. The pairing process can also pair these devices with backend databases associated with the user account. This works by users touching or bringing their smart devices (*e.g.*, a smart phone) in close proximity to an NFC-enabled Bluetooth device. A coil antenna on a circuit board inside the NFC-enabled Bluetooth device receives and converts the RF energy field of the user's smart device to an electrical signal, which can turn on an NFC chip inside the NFC-enabled Bluetooth device. Example NFC chips include NTAG213, NTAG214, NTAG215, manufactured by NXP Semiconductors N.V. of Eindhoven, Netherlands (<https://www.nxp.com/>). Using the same energy harvested through the coil, the NFC chip can return to the smart device of the user, an NFC unique identifier. This NFC unique identifier is linked via a backend software (*e.g.*, a database) to the Bluetooth identifier of the NFC-enabled Bluetooth device (*e.g.*, at the time of manufacturing that product). The user's smart device can use the Bluetooth identifier to pair with the NFC-enabled Bluetooth device and communicate with it via Bluetooth. The pairing information can also be used

to associate the NFC-enabled Bluetooth device with the user's profile and account in a backend a backend database.

[0070] The NFC method of pairing described above can be used to pair a wireless tape 102 with a user's smart device 103, thereby eliminating the need for continuous broadcast of wireless beacons for pairing. Compared to continuous broadcast methods for pairing, the NFC method of pairing a wireless tape 102 and a smart device 103 consumes no battery power and prolongs the life of the wireless tape 102. Additionally, the described NFC pairing technique, can prevent multiple users from simultaneously pairing with the same wireless tape 102 because only the user whose smart device 103 is held within close proximity of the NFC-enabled wireless tape 102 (*e.g.*, within 2-3 centimeters range of the wireless tape 102) can receive the NFC unique identifier and pair with that wireless tape 102.

[0071] However, in some implementations, the inclusion of an NFC chip (such as NTAG213) can add to manufacturing cost of the wireless tape 102, and/or the chip area dedicated to circuitry for pairing. Consequently, it is advantageous to utilize NFC techniques of pairing a wireless tape 102 to a smart device 103, without the use of a dedicated NFC chip for pairing.

[0072] FIG. 4 illustrates a diagram 400 of a wireless tape 102, which can be paired to a smart device 103, without using a dedicated NFC pairing chip. As described earlier, the electronics of the wireless tape 102 can be manufactured on an interconnect layer 118, which is patterned to create electrical connections and isolation between various electrical components on the interconnect layer 118. The diagram 400 does not illustrate every component and layers of an NFC-enabled wireless tape 102. Only some components are shown to illustrate Bluetooth pairing using NFC, without a dedicated NFC chip. An NFC coil antenna 402 and an RF energy harvesting circuit 404 can be manufactured on the interconnect layer 118. A user's smart device 103 is equipped with an NFC transceiver 406 capable of generating and transmitting an RF energy field with wake-up frequency (WUF). The coil antenna 402 is tuned to resonate at the wake-up frequency, WUF sent by the transceiver 406. In some embodiments, the NFC energy harvesting circuit 404 can include components, such as one or more capacitors, and rectifiers to convert an alternating current (AC) signal generated in the coil antenna 402 to a direct current (DC) signal by which the processor 112 can be awakened. In another embodiment, the NFC energy harvesting circuit 404 can include components that capture a wake-up voltage 408 from the coil antenna 402 and transmit the wake-up voltage 408 to the processor 112 to wake up the processor 112. In another embodiment, the NFC energy harvesting circuit 404 and some or all components therein can be skipped. In this scenario, the wake-up AC voltage generated in the coil antenna 402 can be used to directly wake up the processor 112, without converting AC voltages to DC voltages.

Advantages of eliminating some or all of the components of the NFC energy harvesting circuit 404, include, lowering manufacturing cost and complexity of the NFC-enabled wireless tape 102. In other embodiments, some or all of the components of the NFC energy harvesting circuit 404 can be integrated in the processor 112, when the processor 112 is implemented as a system on chip (SOC) solution.

[0073] FIG. 5 illustrates a method 500 of Bluetooth pairing of an NFC-enabled wireless tape 102 with a smart device 103. The processor 112 can be a Bluetooth microprocessor, such as Nordic Semiconductor, nRF52810, as described above, and the wireless communication circuit 111 can be a Bluetooth communication circuit. While the processor 112 and the wireless communication circuit 111 are shown as separate components, in some implementations, they can be part of an integrated Bluetooth chip. The processor 112 includes a general-purpose input/output (GPIO) port capable of receiving GPIO signals. The smart device 103 can be configured to execute program instructions to run the wireless tape application 121. The wireless tape application 121 can configure the transceiver 406 to resonate at the wake-up frequency, WUF. The method 500 starts at the step 502. At step 504, the user of the smart device 103 executes the wireless tape application 121 and brings the smart device 103 in close proximity (*e.g.*, approximately within a 5-centimeter range) of the coil antenna 402 of the wireless tape 102. At step 506, the transceiver 406 generates and transmits an RF energy field at the wake-up frequency, WUF. The coil antenna 402 is tuned to resonate at the wake-up frequency, WUF. At step 508, the coil antenna 402 resonates at the wake-up frequency, WUF, and a wake-up voltage 408 is generated and transmitted to a GPIO port of the processor 112.

[0074] In some embodiments, the NFC energy harvesting circuit 404 can include components that convert the wake-up AC voltage 408 to a DC voltage. However, both a DC or AC voltage can be used at a GPIO port of the processor 112 to wake up the processor 112. For example, in some implementations, voltages (DC or AC) above 0.7 Volts (V) at the GPIO port, can wake up the processor 112. In some instances, a conversion of the wake-up AC voltage 408 to a DC voltage may be desirable to protect the processor 112 from potentially receiving an unsafely high voltage. Nevertheless, the AC to DC conversion in some embodiments can be safely skipped because the range of voltages the NFC-enabled wireless tape 102 and the coil antenna 402 encounter, most likely, do not exceed the levels that may be unsafe for the processor 112. As a result, the wake-up AC voltage 408 generated in the coil antenna 402 can be applied to the GPIO port of the processor 112, without conversion. In this scenario, the NFC-enabled wireless tape 102 can be manufactured, without the components, cost and complexity of converting NFC voltages.

[0075] In implementations, where a threshold voltage to wake up the processor 112 is higher than the range of voltages the coil antenna 402 can generate, a comparator circuit as an external component or as an integrated component in the processor 112, as part of a system on chip (SOC) solution, can receive the wake-up signal and wake up one or more additional circuits in the processor 112. For example, in some implementations the processor 112 can wake up when it receives a voltage above a wake-up threshold voltage of approximately 0.7V, where the antenna coil 402 can generate voltages of approximately 0.3-0.4V or lower. A comparator circuit can detect low voltages generated from the antenna coil 402 (*e.g.*, as low as approximately 1.8V in some implementations) and wake up the rest of the circuitry in the processor 112.

[0076] At step 512, the processor 112 receives the wake-up voltage 408 at its GPIO port and is awakened from an inactive state (*e.g.*, a deep shutdown state). At step 514, the processor 112 uses the wireless communication circuit 111 to send a sequence of Bluetooth beacons 412 (*e.g.*, via low powered BLE signals), which can be received by the wireless communication facilities of the smart device 103. The wireless facilities of the smart device 103 can include Bluetooth communication circuits 414. The Bluetooth beacons 412 can include a Bluetooth identifier, and/or other information which may be included in the pairing process. For example, the Bluetooth beacons 412 can include a unique identifier of the wireless tape 102. At step 516, the wireless tape application 121 can receive the information embedded in the Bluetooth beacon 412 and use them to associate the wireless tape 102 with the user profile of the wireless tape application 121 and the smart device 103. The method 500 ends at the step 518.

[0077] In some embodiments, the Bluetooth beacons 412 can be customized to further identify the wireless tape 102 and/or other information to be included in the pairing process. For example, the Bluetooth beacons 412 can comprise an initial startup sequence having a pre-defined sequence and/or having a predefined power-level, also identified and recorded in the wireless tape application 121. Such information can be uploaded via the wireless tape application 121 upon purchase of a roll of wireless application tapes 102, the dispenser 101 and stored in the local database 120 and/or remote database 122. In some embodiments, a camera of the smart device 103 can be used to scan a barcode from a dispenser 101 or from a roll of wireless tapes 102, where the barcode can include pairing information associated with the wireless tapes 102.

[0078] While the method 500 is described in the context of pairing Bluetooth devices, persons of ordinary skill in the art can appreciate that the described systems and methods can be modified to apply to other communication protocols, such as radio frequency identification (RFID) and others. Additionally, while the described systems and methods of NFC pairing, without a dedicated NFC chip, is described in the context of pairing of wireless tapes 102, the persons of ordinary skill in

the art can appreciate that the described technology can be used in other applications, where pairing of wireless devices are desired. For example, in many applications, wireless device pairings are performed infrequently or only once in the lifetime of the product. At the same time, the cost of an NFC chip used infrequently or only once for an initial pairing, may be prohibitive in several applications. The described technology can be used in these and other scenarios, where pairing of wireless devices is desired.

[0079] *Method for enhancing background performance of Bluetooth beacon proximity detection*

[0080] The Bluetooth communication protocol allows and defines an advertising wireless signal by which Bluetooth-enabled devices can broadcast their presence and availability for connection and communication. Other Bluetooth-enabled devices, such as mobile phones, smart phones and other Bluetooth devices can listen for these advertising signals to determine the presence of Bluetooth-enabled products and can send follow-up messages to those products to inquire about services they can acquire from them. The advertising signals can be connectable or non-connectable. In either case, both types of advertising signals can be used to determine presence and/or proximity. Operating systems of smart devices have special provisions to listen for and detect Bluetooth advertising signals. For example, Apple operating systems detect the advertising signals generated using Apple's iBeacon and Google operating systems detect the advertising signals generated using Google's Eddystone. Both companies have built provisions in their operating systems to detect and to be responsive to these advertising signals in a standard BLE beacon formatted packet. These advertising signals have also been used across many industries for marketing purposes because the advertising signals can indicate the presence and in some cases position data of a customer's mobile phone, based on the strength of the advertising signal received.

[0081] At the same time, a mobile phone or other smart devices which monitor and listen for advertising signals from other Bluetooth devices can waste power from their battery sources, when no other advertising Bluetooth devices may be present. In many cases, there may not be a nearby advertising device. In the case of mobile phones, manufacturers and operating system designers are concerned about such scenarios that lead to inefficient use of battery power in their devices. As a result, most mobile phone manufacturers and operating system designers build provisions in their devices and systems to limit the amount of time their devices are in a state of listening for advertising signals from other devices. At the same time, in order to further save battery power, most battery-operated smart devices, such as smart mobile phones, and their operating systems optimize their background processes to ignore, remove or otherwise limit the resources allocated to redundant and/or redundant background processes or background processes that the device may

determine to be redundant or less critical, such as listening for advertising signals from other Bluetooth devices.

[0082] Mobile phones ignoring broadcasting signals from other devices or limiting background processes associated with them can present a challenge for non-marketing applications, such as asset tracking using wireless labels. The battery resources of wireless labels can be limited and it is advantages that a target mobile phone or smart device receiving these broadcast messages, receives them and affords them a higher priority in processing. Otherwise, the wireless label may need to send multiple broadcast signals and waste its limited battery power in order to connect/communicate with a mobile phone or smart device.

[0083] FIG. 6 illustrates a diagram of a communication protocol between a wireless tape 102 and a smart device 103, which can enhance the background processes of the smart device 103 in relation to the processing of the signals received from the wireless tape 102. In one embodiment, the wireless tape 102 can modify its broadcasting signals 602 to simulate multiple devices sending them. The operating systems of the smart device 103 and similar devices are more likely to listen and allocate more background processes to received broadcasting signals 602 if they appear to be from new devices that they have not listened to before and/or have not processed before. In other words, in the described embodiment, the broadcasting signals 602 are not redundant. The redundancy in the broadcasting signals 602 can be removed by a variety of means.

[0084] In one embodiment, the media access controller (MAC) address and/or the universally unique identifier (UUID) of the wireless communication circuit 111 can be programmatically modified based on a predefined modification algorithm (PMA). If broadcasting signals 602 have varying MAC address and/or varying UUID, the operating system of the smart device 103 perceives the broadcasting signals 602 to have come from different products, which it may have not previously encountered before. Consequently, the operating system of the smart device 103 allocates more background processes and resources to listening, collecting and otherwise processing of the broadcasting signals 602.

[0085] The wireless tape application 121, locally and/or in combination with the server 104 can receive the broadcasting signals 602 and resolve that they are from wireless tape 102, based on the predefined modification algorithm (PMA). For example, in one embodiment, the PMA can be to increment the UUID of every 10 broadcasting signals 602 (where each broadcasting signal 602 comprises a packet) monotonically by a predefined value (*e.g.*, by one). The operating system of the smart device 103 treats the broadcasting signals 602 with higher priority since they have different UUIDs and appear to be from different devices. However, the wireless tape application 121, having the PMA can resolve that every 10 broadcasting signals 602 are from the wireless

tape 102. Other PMAs can also be used. For example, the MAC address and/or the UUID amongst a sequence of broadcasting signals 602 can be modified based on an algebraic expression, where the wireless tape application can use the algebraic expression to derive the original MAC address and/or UUID. In another embodiment, the PMA can be an algorithm that randomizes the MAC address and/or UUID in a sequence of broadcasting signals 602. Yet in other embodiments, hopping and/or omitting MAC addresses and/or UUIDs from a predefined pool of MAC addresses and/or UUIDs can be used.

[0086] FIG. 7 illustrates a method 700 of enhancing the background processes of a smart device 103 in relation to receiving broadcasting signals 602 from the wireless tape 102. The method 700 starts at step 702. At step 704, a sequence of broadcasting signals 602, comprising a predetermined number of broadcasting signals 602 are selected. In one embodiment, a broadcasting signal 602 is a BLE beacon formatted packet. At step 706, the broadcasting signals 602 in the sequence are modified according to a PMA. In some embodiment, the PMA modifies the MAC address and/or the UUID embedded in one or more broadcasting signals 602. At step 708, the wireless tape 102 transmits the sequence of the modified broadcasting signals 602 to a smart device 103. At step 710, the smart device 103 can receive the modified broadcasting signals 602 and route them to the wireless tape application 121. The smart device 103 is more likely to receive some or all of the transmitted sequence of modified broadcasting signals 602 because they appear to be from different sources. At step 712, the wireless tape application 121 can receive the sequence of modified broadcasting signals 602 and determine locally and/or in combination with the server 104, and based on the PMA, that the modified broadcasting signals 602 are from the wireless tape 102. For example, in some embodiments, the wireless tape application 121 and/or the server 104 can apply a reconstructing algorithm based on the PMA to reconstruct the original MAC addresses and/or UUIDs of the received modified broadcasting signals 602. The method 700 ends at step 714.

[0087] The described method of increasing background performance of smart devices 103 in relation to receiving and processing Bluetooth broadcasting signals 602 from the wireless tapes 102 can provide more resolution of data received at the smart device 103 because the receive path on the smart device 103 remains open longer and greater number of broadcasting signals 602 are received at the smart device 103. In addition to saving the battery power resources of the wireless tape 102, the greater resolution of the received data can have advantages, such as greater ability to use the broadcasting signals 602 for positioning of a tracked item with greater accuracy.

[0088] *Method of achieving ultra-low power using changing ambient light levels to trigger power saving states in a microprocessor-based device*

[0089] For many wireless devices (*e.g.*, IOT devices) conserving battery power can be paramount. To maintain an ultrathin profile, many devices use a primary source. When the batter is exhausted, the battery or the device have to be replaced. In many applications, it is often the device that has to be replaced, as changing the used batteries is not a practical option. As a result, many modern wireless devices need to conserve battery to achieve longer product life span. Nonetheless, many wireless devices broadcast their beacon on periodic basis, whether or not a listening device can capture their beacon. This scenario presents a challenge for applications where the broadcasting device has limited battery resources. For example, it is advantageous for an ultrathin profile wireless tape 102, used for tracking items, to broadcast its beacons when a smart device 103 is in the vicinity and capable of receiving the beacons and communicating with the wireless tape 102. It is also advantageous for the wireless tape 102 to limit or stop sending broadcasting beacons, when no smart device 103 is in the vicinity to receive the beacons. Additionally, it is desirable to increase the frequency at which the wireless tape 102 broadcasts its beacons if a smart device 103 is in the vicinity and able to receive and process those beacons. Conversely, it is advantageous to reduce the frequency of (or stop) sending the beacons if no smart device 103 is in the vicinity to receive the beacons.

[0090] Sensors can be used to modulate the broadcasting of beacons and/or their sending frequency in order to save battery resources. For example, vibration or motion sensors can be used in wireless devices (such as the wireless tape 102) to trigger and/or to modulate the sending frequency of broadcasting beacons emitted from the wireless device. If sensors detect motion and/or vibration, the wireless device can increase the frequency of sending broadcasting beacons. However, in some applications, the sensors consume more battery resources than they save. For example, in some applications, motion sensing with passive infrared (PIR) or similar motion sensors and motion sensing with an accelerometer to save battery resources can task the battery resources more than they save the battery resources. Yet in other applications, the cost of the additional sensors can be prohibitive in relation to the overall target cost of the product, thus making the use of these sensors impractical. For other wireless devices, the form factor and sizes of these sensors can be incompatible with their form factor or design.

[0091] In the case of wireless devices that operate by NFC, solar or other energy harvesting methods, the battery resources can be limited. Thus, it is advantageous to reduce or minimize broadcasting beacons, when no listening smart device 103 is in the vicinity.

[0092] In one embodiment, fluctuations of light levels in the environment of a wireless device can be used to modulate the frequency of broadcasting beacons. In this scenario, fluctuations in light levels in the environment can indicate the presence of a listening smart device 103. For example,

when wireless device, such as the wireless tape 102 is used for asset tracking, the wireless tape 102 may be attached to an item, which is placed in a delivery van, a work truck, a supply room or other physical locations, where that item and the attached wireless tape 102 are stored. When a person carrying the smart device 103, who has an interest in the tracked item, enters the physical location where the item and the attached wireless tape 102 are located, the environment likely can experience fluctuations in light level. For example, an automatic motion sensor in the environment can turn the lights on, when the person enters the environment. Or when the person opens the door to a storage area (such as the cargo compartment of a van or truck), the storage area, where the tracked item and wireless tape 102 are located can be exposed to outside light and experience fluctuations in light levels.

[0093] FIG. 8 illustrates an embodiment of the wireless tape 102, where fluctuations in light levels can be used to modulate the frequency of broadcasting beacons. The wireless tape 102 in this scenario includes a photovoltaic layer 310 (as described in relation to FIG. 3) and an energy harvesting circuit 802. Fluctuations in light levels can occur due to the photovoltaic layer 310's exposure to various light sources 804. The photovoltaic layer 310 and the energy harvesting circuit 802 convert light to an electrical signal 804 (*e.g.*, a voltage or current), which can be received by the processor 112. The processor 112 can modulate the frequency of beacons sent from the wireless communication circuit 111, based on the value of the electrical signal 804. For example, the processor 112 can increase the frequency of broadcasting beacons, based on a rate of increase in the voltage received in the electrical signal 804. Accordingly, when a person carrying a smart device 103 enters the environment of the wireless tape 102 and exposes the photovoltaic layer 310 to fluctuations of light levels, the voltage generated by the energy harvesting circuit 802 can increase at a rapid rate, R1. The processor 112 can correspondingly increase the rate of broadcasting beacons from the wireless communication circuit 111 at the rate R1 or to an increased rate based on R1. In this manner, the increased broadcasting beacons have a better chance of detection by the smart device 103.

[0094] Conversely, if light fluctuations in the environment of the photovoltaic layer 310 is minimal, the voltage/current of the electrical signal 804 does not change or changes at a reduced rate, R2. The processor 112 can adjust the frequency of broadcasting beacons from the wireless communication circuit 111 to be at the reduced rate, R2 or another reduced rate based on R2. If R2 is zero, the frequency of broadcasting the beacons can be also zero or a reduced amount (*e.g.*, every thirty seconds) in order to conserve the battery energy. In some embodiments, the electrical signal 804 can be used to wake up the processor 112 and begin broadcasting beacons.

[0095] FIG. 9 illustrates a method 900 of using fluctuations in light level to modulate the frequency of a broadcasting beacon. The method 900 starts at step 902. At step 904, the photovoltaic layer 310 and the energy harvesting circuit 802 generate an electrical signal by converting light energy from various light sources 804. At step 906, the processor 112 receives the electrical signal 804 and determines a rate of change of the electrical signal 804, based on fluctuations in converted light energy. At step 908, the processor 112 modulates the frequency of the broadcasting beacons sent from the wireless communication circuit 111, based on the determined rate. The method 900 ends at step 910.

[0096] *Methods of modulating the frequency of broadcasting beacons from the wireless tape 102*

[0097] Since the ultrathin form factor of wireless tape 102 can limit the battery size and capacity, ultra-low-power methods may be employed to optimize how beacons are sent from the wireless tape 102. Continuously sending wireless beacons even at a very low frequency can consume a considerable amount of power, unnecessarily, if no smart device 103 or receiving/listening device is present within range to listen for the wireless beacons. Therefore, it is advantageous to not send wireless beacons when no person carrying the smart device 103 is in the vicinity. An approach is employed to achieve this by taking advantage of the electrostatic effects on the wireless tape 102, when the environment around the wireless tape 102 changes. For instance, those changes might include, touching, moving, obscuring an item with the attached wireless tape 102, or even walking-by or touching another item nearby can all have an effect on the voltage potential present over various surface areas of the wireless tape 102. In one respect, the wireless tape 102 can function as a layered capacitor, whose charge level can be detected and used to modulate the frequency of wireless beacons it sends.

[0098] Changes in the voltage present on one or more surfaces of the wireless tape 102 can be measured by an analog-to-digital converter (ADC) periodically, or one or more conductive surfaces of the wireless tape 102 may be connected as inputs to a comparator circuit to trigger a wake up. Referring now to FIG. 3, electronics 306 can include a processor 112, which can in turn include an ADC and/or a comparator circuit. The ADC can periodically sample voltages/currents from at least one of the electrically conductive surfaces of the wireless tape 102. Example surfaces, which can be used include the interconnect layer 118 and/or the anode layer 302. A direct high-impedance connection can be made from an input of the ADC to the conductive surface in order to save manufacturing costs. The rate of change of voltages/currents received at the input of the ADC can be monitored among a plurality of sampled input data. If the rate changes more than a predetermined threshold between the samples, it can be inferred that something in the environment of the wireless tape 102 has changed, with a likelihood that those changes were

caused by human motion, indicating the presence of a person. Since people carry smart devices 103 with them, the wireless tape 102 can correspondingly increase the frequency of broadcasting wireless beacons when changes that are likely due to human presence are detected as described above. In this manner, there is a higher likelihood that the increased broadcasting beacons can be received by a smart device 103.

[0099] The method of measuring the electrostatic potential obtained from a single conductive plane within the wireless tape 102, in some cases, can be prone to interference and error from noise. In particular, the 50-60 Hz noise due to power line noise can be present in many environments, causing errors in detecting a voltage/current change due to an environmental change indicative of human presence. At the same time, to conserve the battery resources of the wireless tape 102, it may not be desirable to sample the surface voltage/current at an increased rate in the processor 112 and remove the noise digitally. Furthermore, cost constraints, can make filtering with added electrical components also a less desirable option. Therefore, one embodiment uses a differential ADC sampling method by receiving two inputs from two adjacent conductive planes of the wireless tape 102 to detect and reject the common mode noise. Voltage/current changes can be measured differentially. The ADC can measure the voltages/currents on the two conductive surfaces (*e.g.*, the interconnect layer 118 and the anode layer 302 or other conductive parallel plates in wireless tape 102) and the readings can be passed as signals to the processor 112. When the processor 112 determines that the difference between the readings exceeds a predetermined threshold, then this can indicate a change in the environment and the processor can modulate the frequency of broadcasting beacons accordingly.

[0100] Another method of reducing noise and increasing reliability is to sample multiple, electrically isolated planes of the wireless tape 102, either within a sample plane or within parallel planes (*e.g.*, between parallel planes that form a capacitor within the wireless tape 102) and average the readings from the multiple planes. Since in some embodiments, the wireless tape 102 can resemble a capacitor, after a change in the environment of the wireless tape 102 causes a voltage differential to occur in the parallel plates of the capacitor, the time constant of the capacitor formed by parallel planes within the wireless tape 102 discharges to a stable equilibrium. The time constant parameter can be measured or derived from the voltage readings and a rate of frequency of broadcast of beacons can be correspondingly adjusted.

[0101] *Additional methods of activating the wireless tape 102*

[0102] It is advantageous to conserve the battery resources of the wireless tape 102 by maintaining the electronics 306 in a low-power or off-state, until the wireless tape 102 is to be used. FIG. 10 illustrates diagrams of various embodiments to maintain the wireless tape 102 in a low-power

state when in storage or before deployment by a user of the object tracking system 100. In one embodiment, two conductive planes 1002 and 1004 can be patterned on the interconnect layer 118 or in one or more layers of the wireless tape 102 in a manner that the conductive planes 1002 and 1004 form a part of an edge 1006 of the wireless tape 102. The edge 1006 can be an edge between two discrete wireless tapes 102 (*e.g.*, from a roll of wireless tapes 102). A metal cutting means 115 can shear the roll of wireless tapes 102 and separate them at edge 1006. The same process can be utilized to activate/wake-up the processor 112 and/or other electronics of the wireless tape 102. The interconnect layer 118 is patterned to electrically connect the conductive plane 1002 to a GPIO port of the processor 112 and the conductive plane 1004 to the battery 114. For ease of illustration, the battery 114 is shown as a single component on the interconnect layer 118. However, as described earlier in relation to FIG. 3, the battery 114 can be a layered structure on multiple layers of the wireless tape 102. The cutting means 115 can be made of a metal material, which can electrically connect the conductive planes 1002 and 1004 during the shearing of the edge 1006, thereby generating a signal at the GPIO port of the processor 112 from the battery 114. The signal at the GPIO port of the processor 112 can wake-up and activate the processor 112. The processor 112 can send beacons to nearby smart devices 103 for connection and communication.

[0103] In another embodiment, the conductive planes 1002 and 1004 can be patterned on the same surface of the interconnect 118 and on the opposite edges 1014 and 1016 of the wireless tape 102, respectively. The conductive planes 1002 and 1004 can be electrically connected to conductive planes 1008, 1010, respectively. The conductive planes 1008 and 1010 are formed on an external surface 1018 of the wireless tape 102, from an electrically conductive and adhesive material, on the opposite edges 1014 and 1016 of the wireless tape 102, respectively. The conductive planes 1002 and 1004 and the conductive planes 1008 and 1010 are electrically coupled via interconnect patterns in the interconnect layer 118 to the terminals of a GPIO port 1012 of the processor 112. In this arrangement, the conductive planes 1002, 1004, 1008 and 1010 form an open switch between the terminals of the GPIO port 1012. When a user of the wireless tape 102 intends to activate the wireless tape 102, he can bring the opposite edges 1014 and 1016 of the wireless tape 102 together and adhere the conductive planes 1008 and 1010 together. Connecting the conductive planes 1008 and 1010 closes the switch and connects the terminals of the GPIO port 1012, generating a signal in the processor 112 and causing the processor 112 to wake up and begin transmitting beacons for connection and communication. In another embodiment, the conductive planes 1008 and 1010 from the external surface 1018 of the wireless tape 102 can be routed to the terminals of the GPIO port 1012, directly or via interconnect patterns in the interconnect layer

118. In this scenario, the conductive planes 1002 and 1004 on the interconnect layer 118 can be excluded and not manufactured.

[0104] *Example applications of the object tracking system 100*

[0105] In one embodiment, a process of setup and configuration of the wireless tape 102 can configure a wireless tape 102 to track an item. The wireless tape application 121 can be running in the background. When a wireless beacon from a wireless tape 102 is received. The wireless tape application 121, can determine whether it has encountered this wireless tape 102 before. If it is determined that the wireless tape 102 is encountered for the first time, the wireless tape application 121 can prompt the user to assign the wireless tape 102 to an item the user wishes to track. The user can also physically affix the wireless tape 102 to the item using the adhesive layer 304. Upon reception of any beacon from a wireless tape 102 at the device 103, the wireless tape application 102 can query the local database 120 to determine if the beaconing wireless tape 102 is already registered and configured with the wireless tape application 121. If the wireless tape 102 is not registered, the wireless tape application 121 can query the remote database 122 to determine if the wireless tape 102 has been registered with another user. If neither is true, the wireless tape application 121 prompts the user for additional information regarding the item and registers the wireless tape 102 with the user and the associated item. In some embodiments, the use can provide a descriptive text string, such as, “passport,” or “umbrella.” In other embodiments, the user may use a camera device of the smart device 103 to capture an image of the item, which can be associated with the wireless tape 102.

[0106] The prompt for additional information during registration of a wireless tape 102 and its associated item, may also give the user options to set how the wireless tape application 121 should behave as to the associated item. For instance, the wireless tape application 121 can be configured to send reminders regarding a tracked item if some predefined conditions are met. For example, the wireless tape application 121 can be configured to remind a user to bring a tagged passport on a future date, if on that date, the tagged passport is not detected to be with the user, to bring a tagged umbrella if rain is expected in the weather forecast and the tagged umbrella is not detected to be with the user, as the user leaves the home-base geofence.

[0107] In some embodiments, the setup process of a wireless tape 102 can include a machine learning mechanism to reduce the need for user input during the setup of the wireless tape 102. Simply sticking the wireless tape 102 on items of importance in the user’s daily life, the wireless tape application 121 can learn what the user typically brings with him from place to place during the day. It can anticipate this by employing machine learning algorithms that may also employ external variables including the weather and the user’s digital calendar. If for example the user

always brings his gym bag on Tuesdays and Thursdays, the wireless tape application 102 may predict that the user needs the gym bag on these days. It may be that the user happens to have meetings on those days that are near the gym. The learning mechanism may predict that if the user has a meeting with the same person on a Wednesday, the user may also need the gym bag and a notification can be sent reminding the user to bring the gym bag.

[0108] A machine learning model may be trained based on data collected from the user to determine the conditions under which certain items are typically with the user. In this way, the machine learning model may be trained to predict, based on conditions, which items should be in the user's possession. Training may involve determining when an item is in the presence of the user based on receiving the beacon from the wireless tape 102. The conditions at the time that the wireless tape 102 is present may also be determined, such as the day of the week, time of day, weather, presence and identity of other users in the vicinity, and so on. The aforementioned data may comprise training examples used to train the machine learning model to build an association between input conditions and a prediction of whether the item is present or not.

[0109] After training, a set of conditions, of any of the aforementioned types, may be input to a machine learning model. The machine learning model may then output a prediction, based on those conditions, of which items should be in the possession of the user and at what times. When it is determined that one of the predicted items is not in the presence of the user (for example, no beacon from an associated wireless tape 102 is received), then an alert may be triggered.

WHAT IS CLAIMED IS:

1. A wireless tape comprising:
 - a polyester substrate;
 - an interconnect layer coated on the polyester substrate and patterned to electrically couple a plurality of electrical circuits, wherein the electrical circuits are formed and/or bonded on the interconnect layer, and comprise a Bluetooth processor, a Bluetooth communication circuit configured to broadcast beacons at a broadcast frequency, and an energy harvesting circuit;
 - a photovoltaic layer coupled to the energy harvesting circuit, wherein the photovoltaic layer and the energy harvesting circuit are configured to generate an electrical signal from converting light to the electrical signal; and
 - a battery comprising a cathode and anode layer and a battery pouch disposed on the interconnect layer, wherein the interconnect layer comprises the cathode layer, and wherein the Bluetooth processor is configured to:
 - receive the electrical signal;
 - determine a rate of change of the electrical signal; and
 - modulate the broadcast frequency, at least in part, based on the determined rate of change of the electrical signal.
2. The wireless tape of claim 1, wherein the Bluetooth processor is further configured to:
 - select a sequence of broadcasting signals, comprising a predetermined number of broadcasting signals;
 - modify the broadcasting signals in the sequence based on a predetermined modification algorithm; and
 - signal the Bluetooth communication circuit to transmit the sequence of the modified broadcasting signals to a smart device.
3. The wireless tape of claim 2, wherein the smart device receives and routes the sequence of modified broadcasting signals to a wireless tape application running on the smart device and the wireless tape application reconstructs unmodified broadcasting signals from the received modified broadcasting signals, based on the predetermined modification algorithm.
4. The wireless tape of claim 3, wherein the predetermined modification algorithm comprises modifying a MAC address and/or a UUID in the broadcasting signals.
5. The wireless tape of claim 1, further comprising:
 - a coil antenna formed and/or disposed on the interconnect layer and tuned to resonate at a frequency generated by a transceiver of a smart device; and

wherein the coil antenna is electrically coupled to a GPIO port of the Bluetooth processor, wherein the coil antenna is configured to receive RF energy field generated by the transceiver and convert the RF energy to an AC signal, and transmit the AC signal the GPIO port of the Bluetooth processor waking up the Bluetooth processor, and wherein the Bluetooth processor begins transmitting a wireless beacon comprising a startup sequence, having a predefined power level and an identifier of the Bluetooth processor and the Bluetooth communication circuit.

6. The wireless tape of claim 1, wherein the Bluetooth processor further comprises an ADC configured to receive voltages from a conductive surface of the wireless tape and the Bluetooth processor is further configured to determine a rate of change of the voltages from the conductive surface and modulate the broadcast frequency, at least in part, based on the determined rate of change of the voltages from the conductive plane.

7. The wireless tape of claim 1, wherein the Bluetooth processor further comprises an ADC configured to receive voltages from a pair of parallel conductive surfaces of the wireless tape and the Bluetooth processor is further configured to modulate the broadcast frequency, at least partly, based on difference between voltages received from the parallel conductive surfaces.

8. The wireless tape of claim 1 further comprising a first conductive plane and a second conductive plane formed on the interconnect layer and forming a part of an edge of the wireless tape, wherein the interconnect layer is further patterned to electrically couple the first conductive plane to a terminal of the battery and the second conductive plane to a GPIO port of the Bluetooth processor.

9. The wireless tape of claim 1, further comprising a first conductive plane and a second conductive plane formed on opposite edges of the wireless tape and on an external surface of the wireless tape, wherein the interconnect layer is further patterned to connect the first and second conductive planes to terminals of a GPIO port of the Bluetooth processor, and wherein the first and second conductive planes comprise an electrically conductive adhesive layer.

10. A dispenser configured to dispense the wireless tape of claim 1.

11. A method comprising:

providing a polyester substrate;

coating an interconnect layer on the polyester substrate and patterning the interconnect layer to electrically couple a plurality of electrical circuits, wherein the electrical circuits are formed and/or bonded on the interconnect layer, and comprise a Bluetooth processor, a Bluetooth communication circuit configured to broadcast beacons at a broadcast frequency, and an energy harvesting circuit;

providing a photovoltaic layer coupled to the energy harvesting circuit, wherein the photovoltaic layer and the energy harvesting circuit are configured to generate an electrical signal from converting light to the electrical signal; and

forming a layered battery comprising a cathode and anode layer and a battery pouch disposed on the interconnect layer, wherein the interconnect layer comprises the cathode layer, and wherein the Bluetooth processor is configured to:

receive the electrical signal;

determine a rate of change of the electrical signal; and

modulate the broadcast frequency, at least in part, based on the determined rate of change of the electrical signal.

12. The method of claim 11, wherein the Bluetooth processor is further configured to:

select a sequence of broadcasting signals, comprising a predetermined number of broadcasting signals;

modify the broadcasting signals in the sequence based on a predetermined modification algorithm; and

signal the Bluetooth communication circuit to transmit the sequence of the modified broadcasting signals to a smart device.

13. The method of claim 12, wherein the smart device receives and routes the sequence of modified broadcasting signals to a wireless tape application running on the smart device and the wireless tape application reconstructs unmodified broadcasting signals from the received modified broadcasting signals, based on the predetermined modification algorithm.

14. The method of claim 13, wherein the predetermined modification algorithm comprises modifying a MAC address and/or a UUID in the broadcasting signals.

15. The method of claim 11, further comprising:

forming and/or disposing a coil antenna on the interconnect layer;

tuning the coil antenna to resonate at a frequency generated by a transceiver of a smart device; and

electrically coupling the coil antenna, and a GPIO port of the Bluetooth processor, wherein the coil antenna is configured to receive RF energy field generated by the transceiver and convert the RF energy to an AC signal, and transmit the AC signal to the GPIO port of the Bluetooth processor waking up the Bluetooth processor, and wherein the Bluetooth processor begins transmitting a wireless beacon comprising a startup sequence, having a predefined power level and an identifier of the Bluetooth processor and the Bluetooth communication circuit.

16. The method of claim 11, wherein the Bluetooth processor further comprises an ADC configured to receive voltages from a conductive surface of the wireless tape and the Bluetooth processor is further configured to determine a rate of change of the voltages from the conductive surface and modulate the broadcast frequency, at least in part, based on the determined rate of change of the voltages from the conductive plane.

17. The method of claim 11, wherein the Bluetooth processor further comprises an ADC configured to receive voltages from a pair of parallel conductive surfaces of the wireless tape and the Bluetooth processor is further configured to modulate the broadcast frequency, at least partly, based on difference between voltages received from the parallel conductive surfaces.

18. The method of claim 11 further comprising forming a first conductive plane and a second conductive plane on the interconnect layer and as a part of an edge of the wireless tape; and further patterning the interconnect layer to electrically couple the first conductive plane to a terminal of the battery and the second conductive plane to a GPIO port of the Bluetooth processor.

19. The method of claim 11, further comprising forming a first conductive plane and a second conductive plane on opposite edges of the wireless tape and on an external surface of the wireless tape; and further patterning the interconnect layer to connect the first and second conductive planes to terminals of a GPIO port of the Bluetooth processor, and wherein the first and second conductive planes comprise an electrically conductive adhesive layer.

20. An object tracking system, comprising:

the wireless tape of claim 1;

a wireless tape application, comprising program instructions to execute the wireless tape application on a computer device, and wherein the wireless tape application is configured to:

receive the broadcast beacons, comprising a unique identifier of the wireless tape;

query one or more databases to determine if the wireless tape is associated with a user and/or an item;

receive an input from the user comprising a description of an item to be tracked;

update the one or more databases with an association of the user and/or the item to be tracked and the unique identifier; and

monitor the broadcast beacons and alert the user if the broadcast beacons are not received after a threshold period of time.

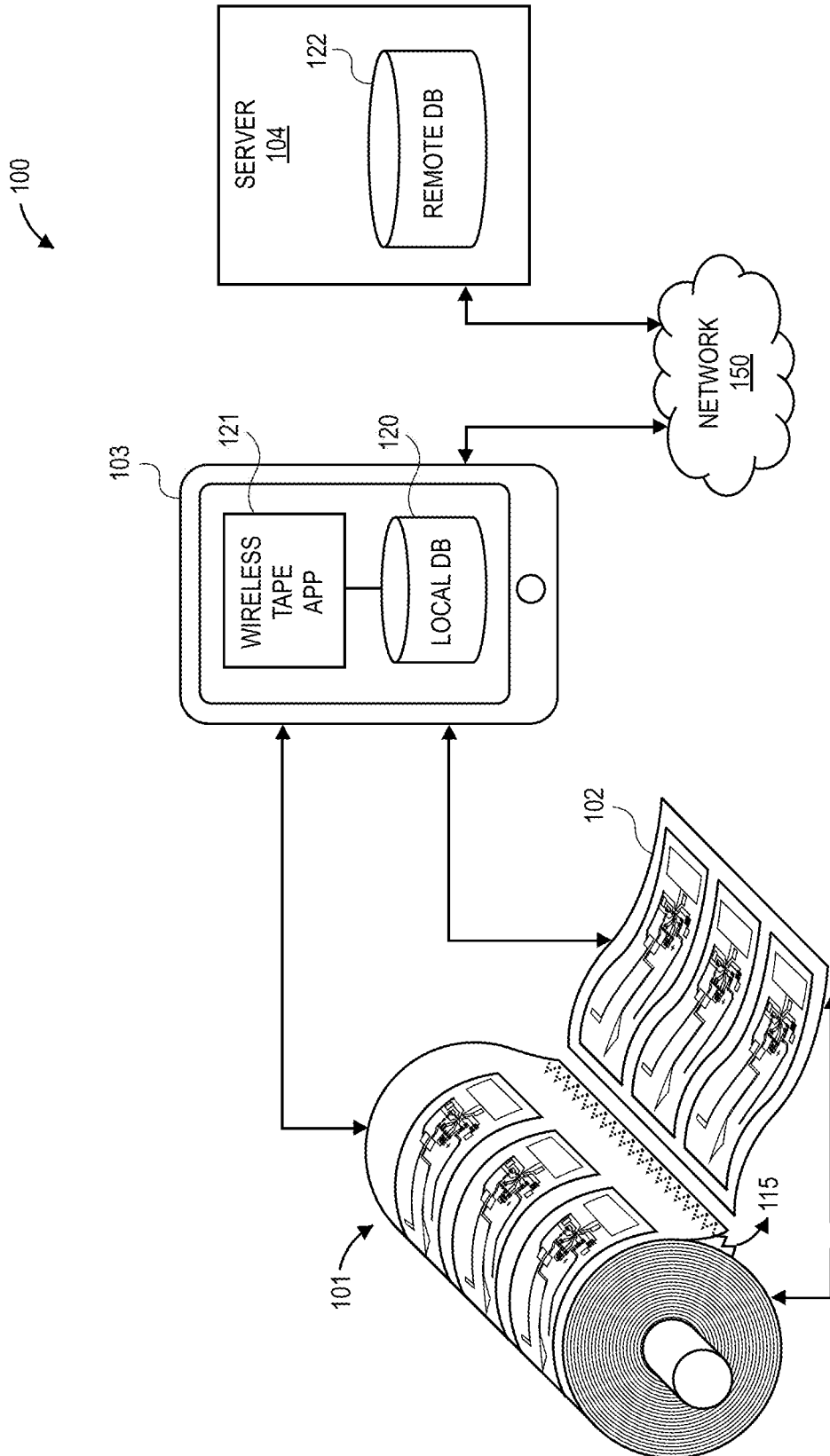

FIG. 1A

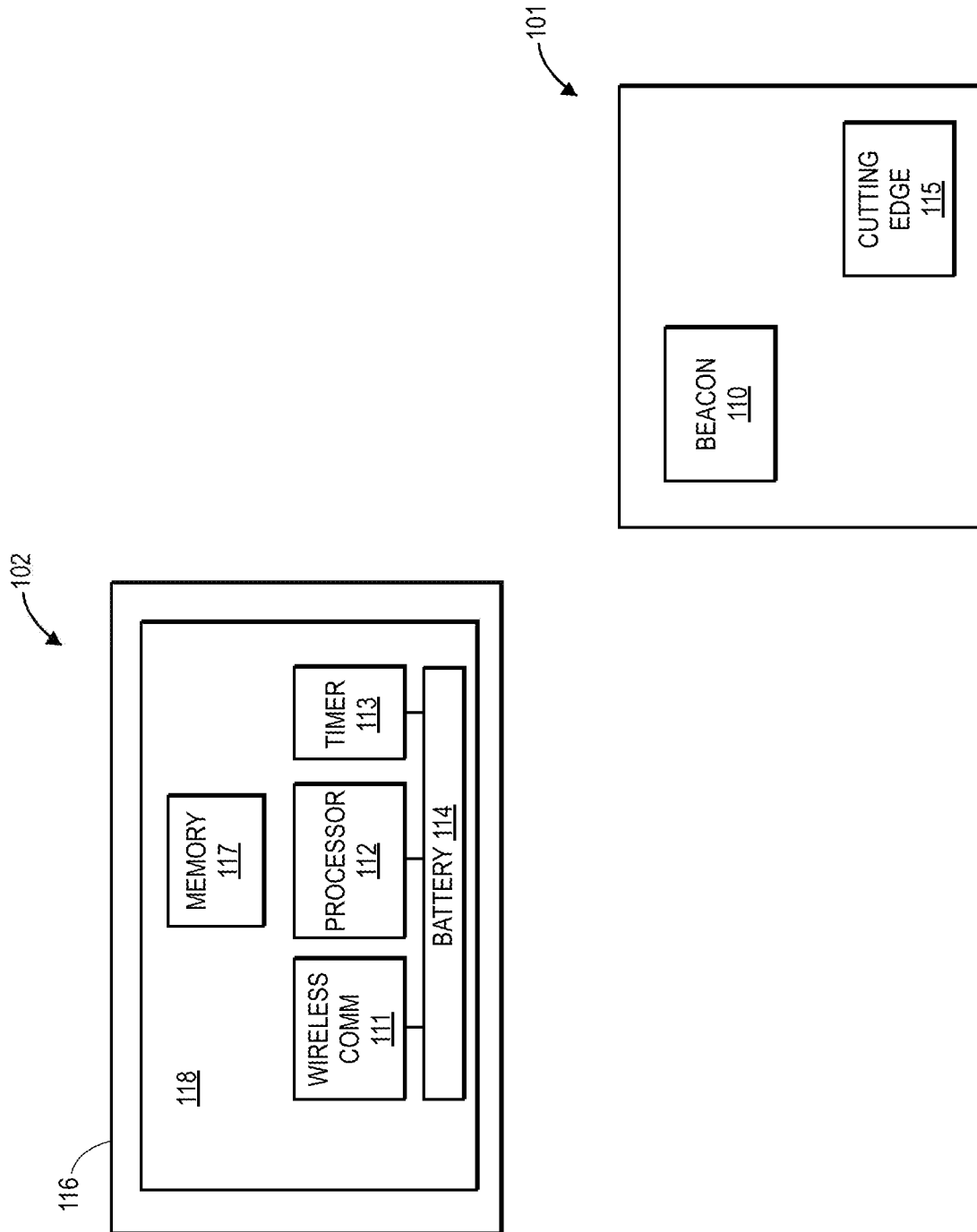

FIG. 1B

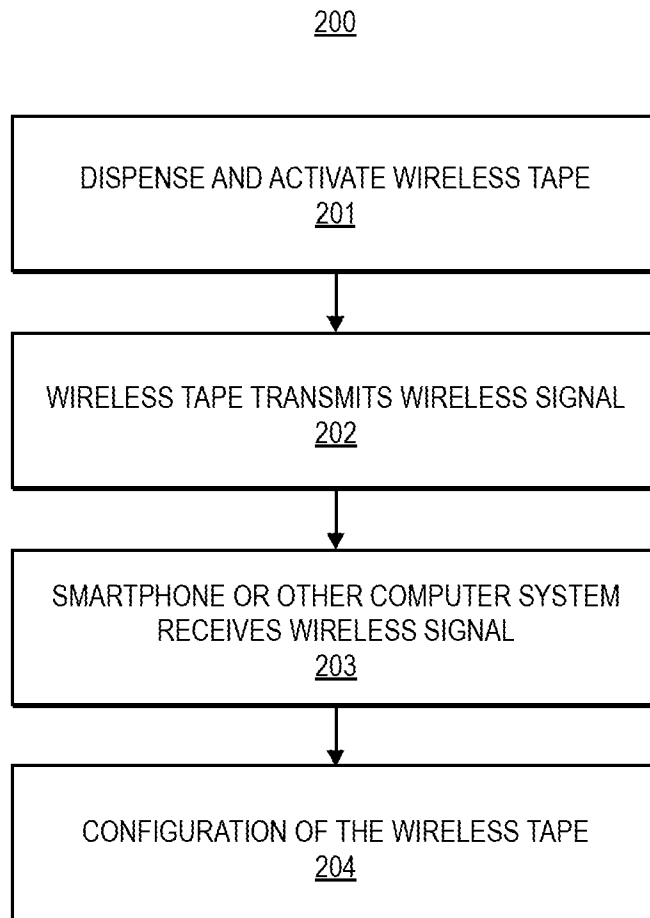
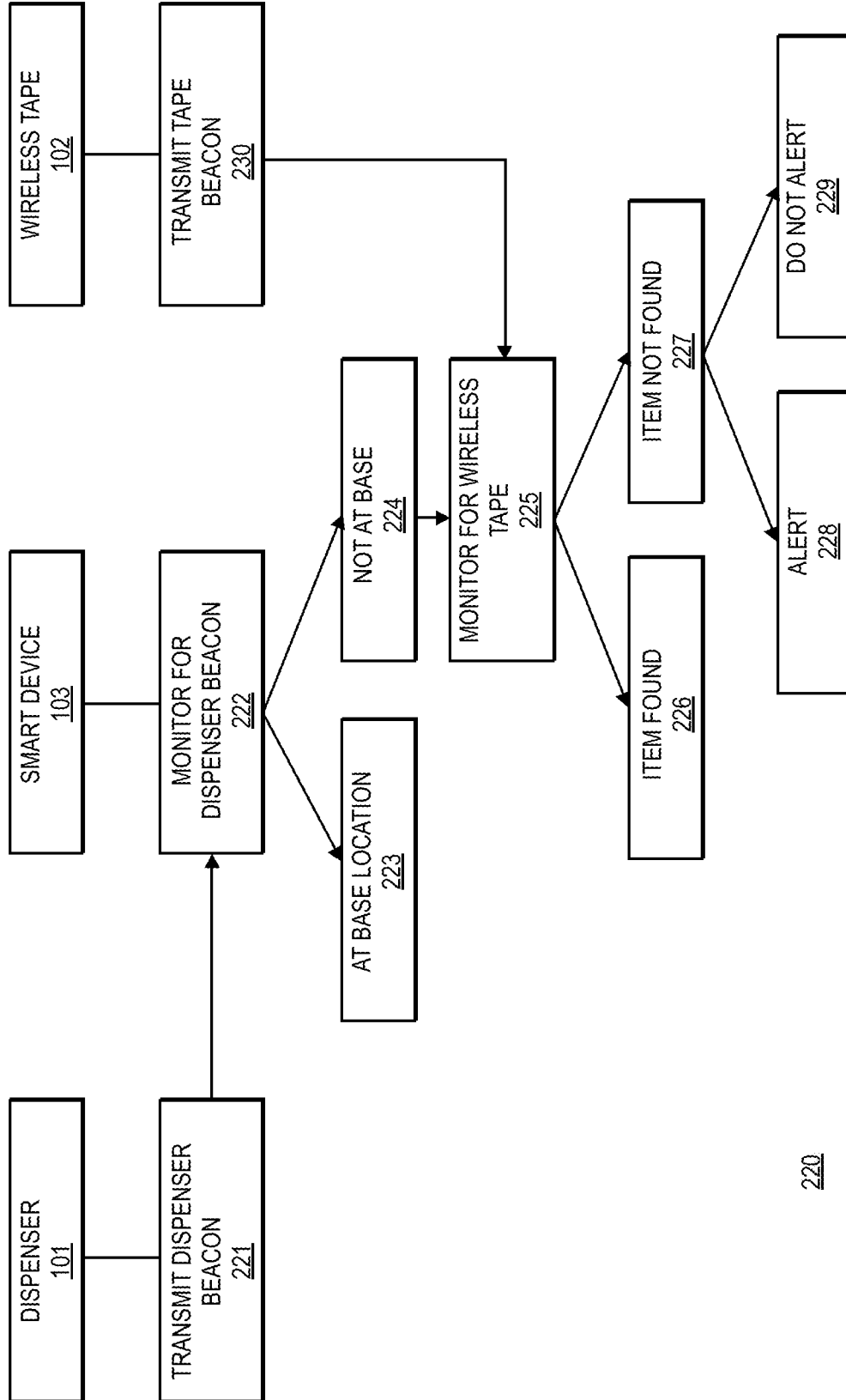

FIG. 2A



220

FIG. 2B

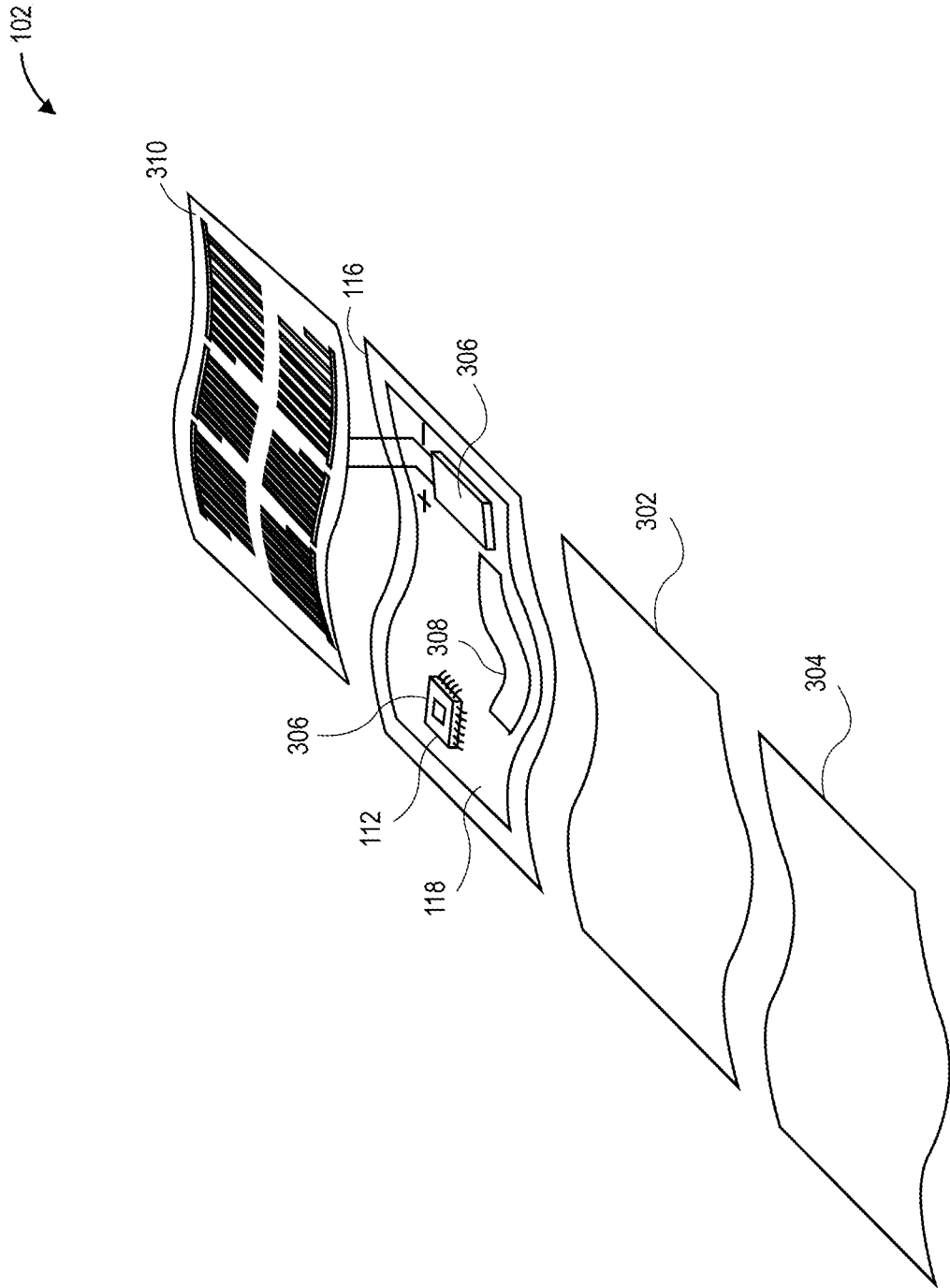

FIG. 3

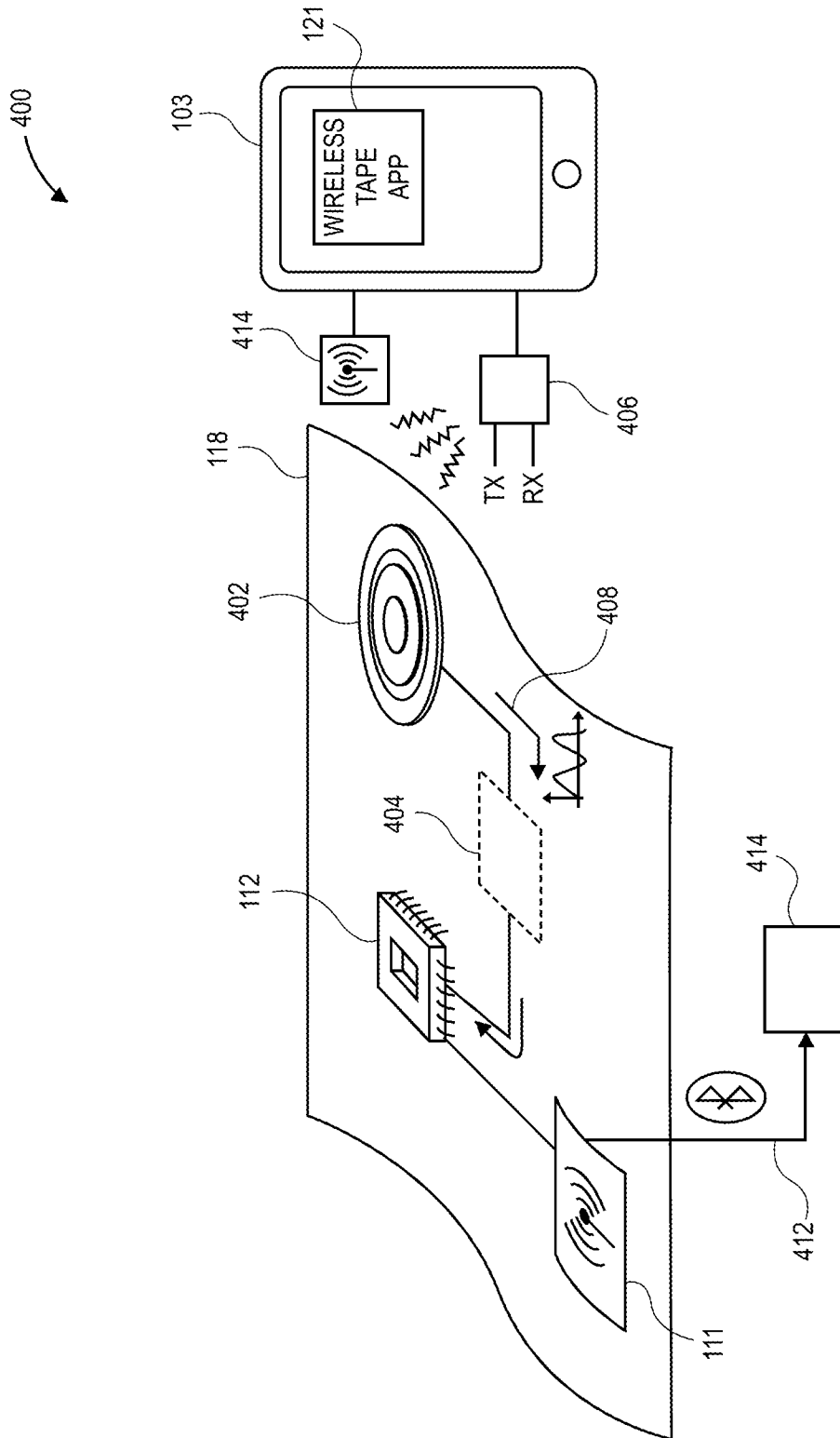

FIG. 4

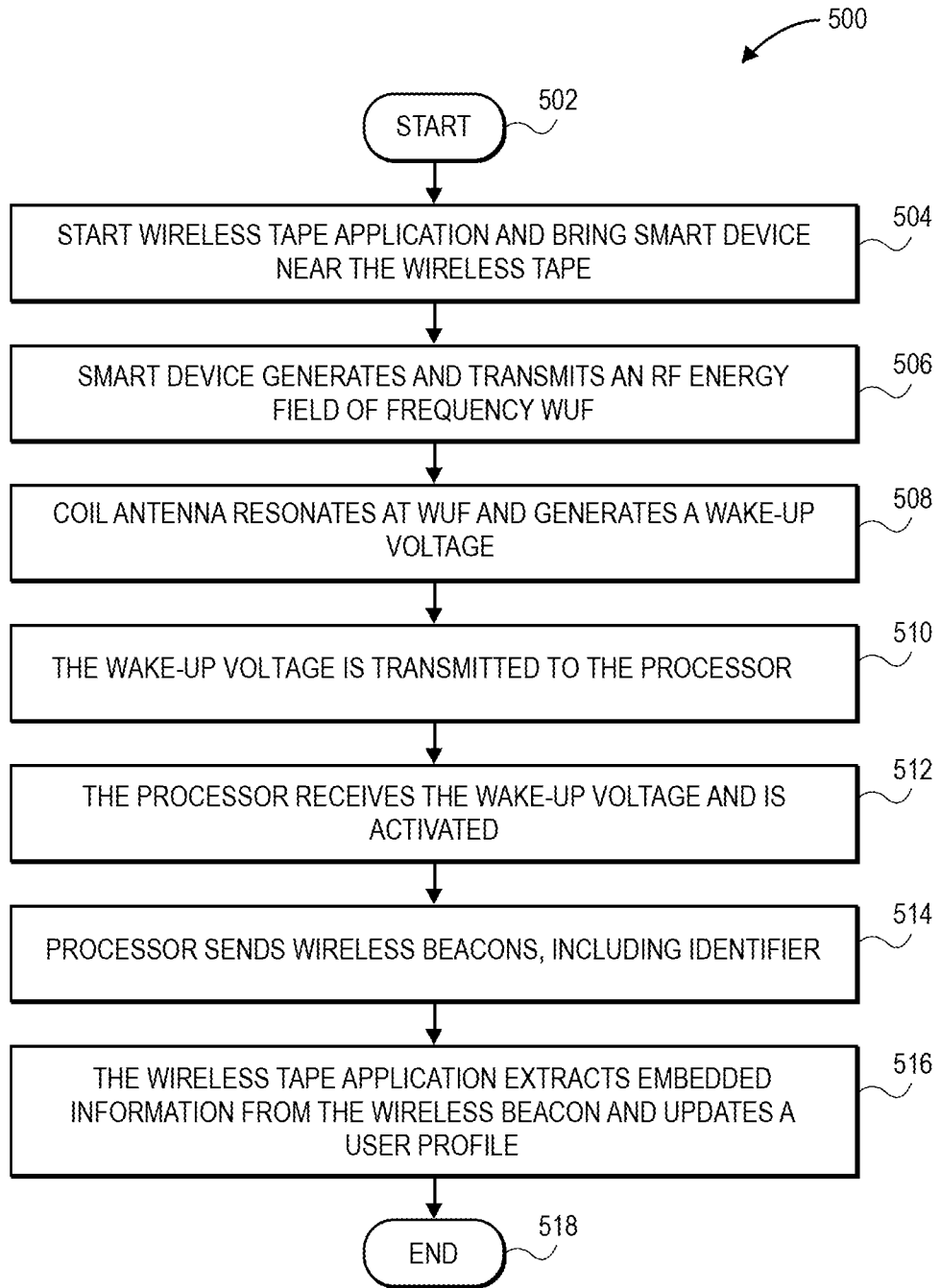

FIG. 5

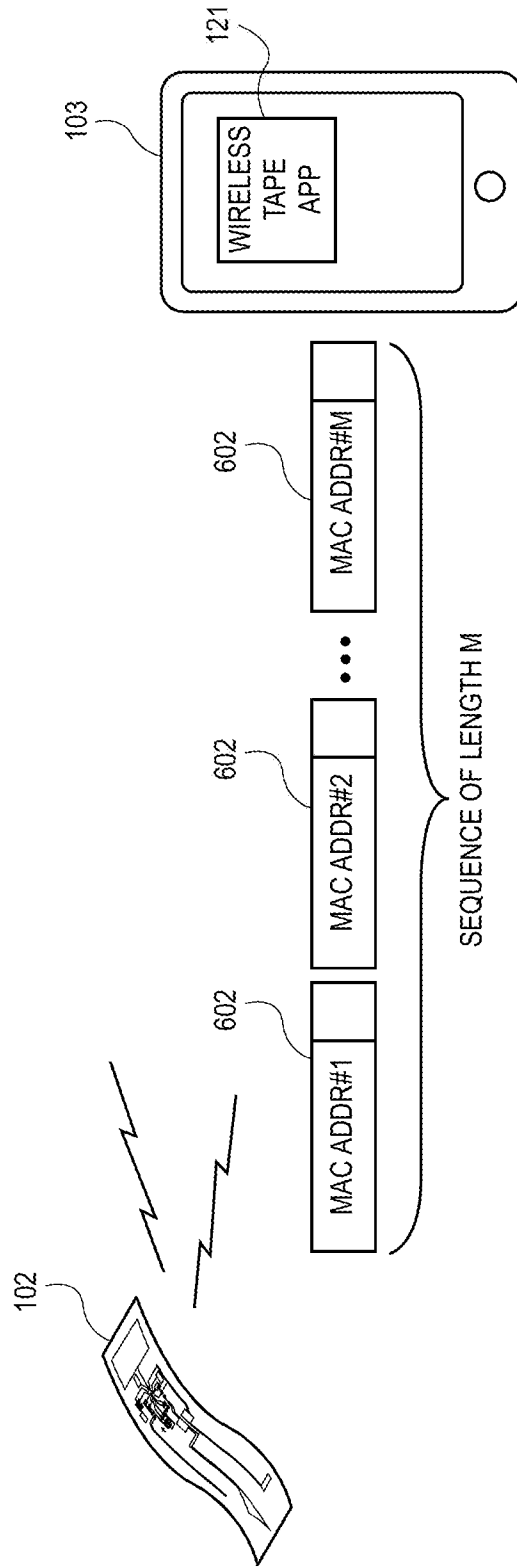

FIG. 6

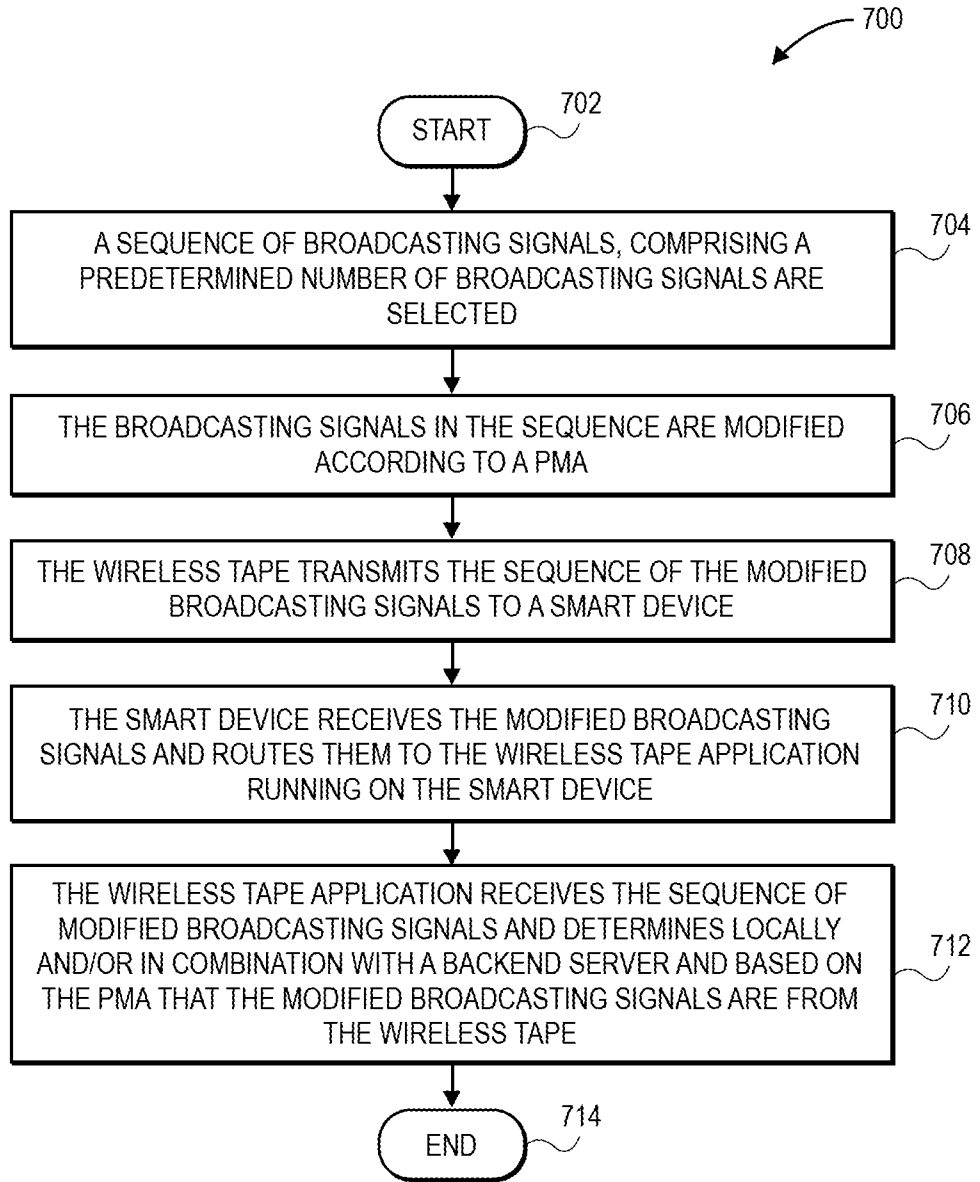

FIG. 7

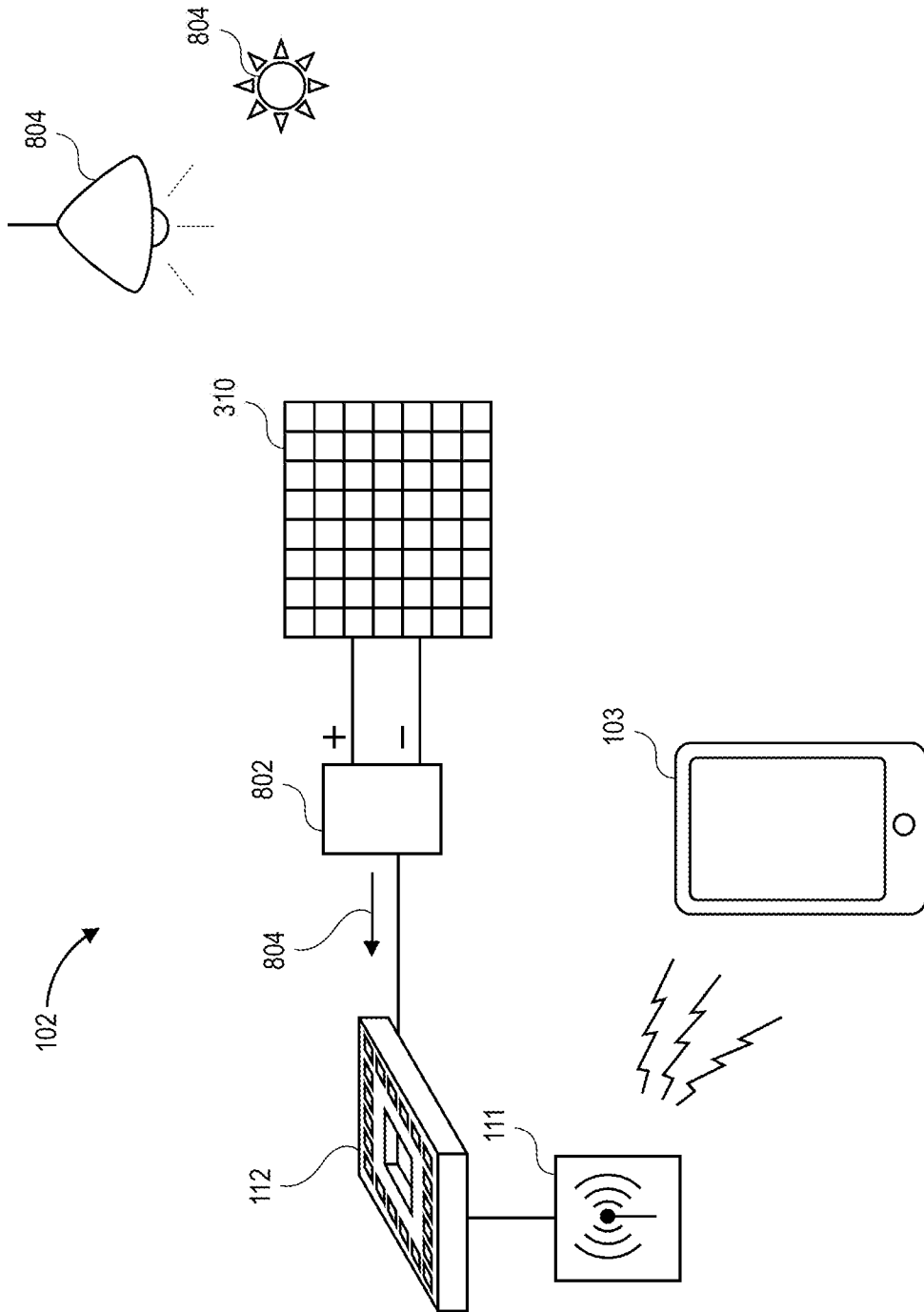
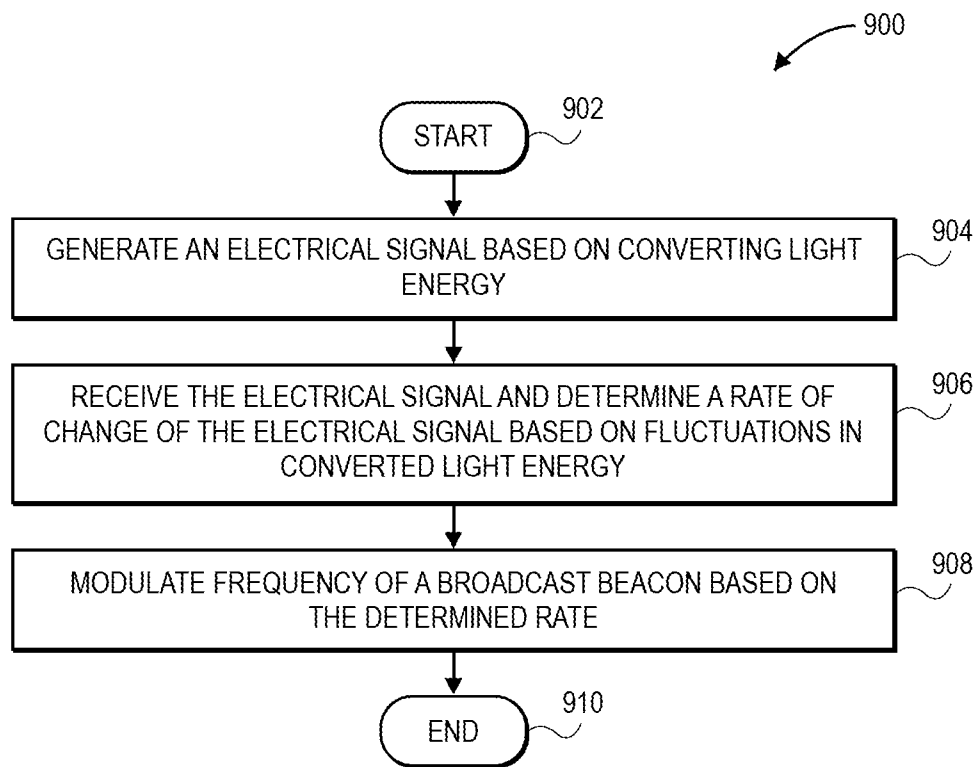

FIG. 8

11/12

**FIG. 9**

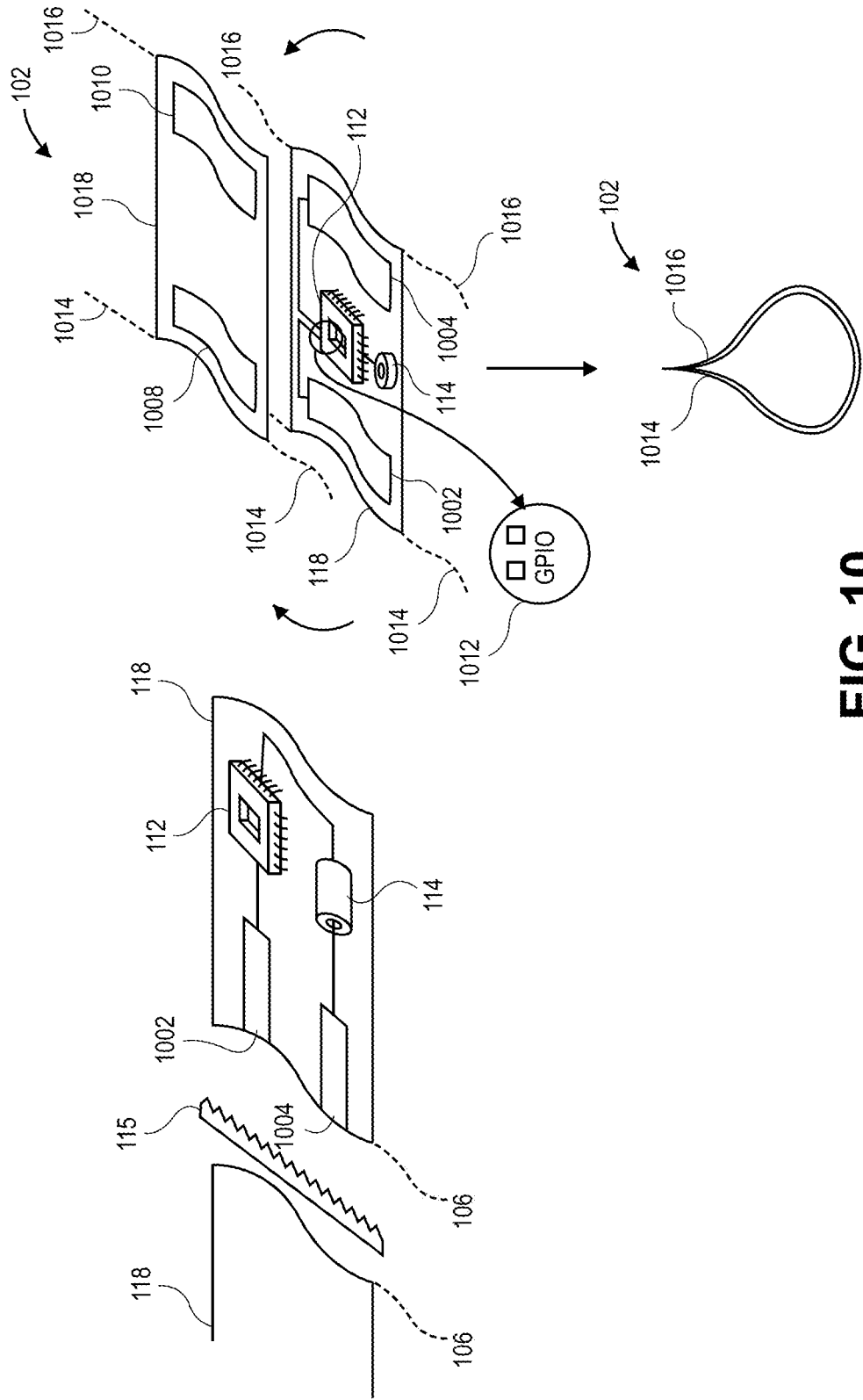

FIG. 10

INTERNATIONAL SEARCH REPORT

International application No.

PCT/US19/55272

A. CLASSIFICATION OF SUBJECT MATTER

IPC - H04W 4/029, 4/80; G06K 19/07 (2019.01)

CPC - H04W 4/029, 4/80; G06K 19/07, 19/0702, 19/0707

According to International Patent Classification (IPC) or to both national classification and IPC

B. FIELDS SEARCHED

Minimum documentation searched (classification system followed by classification symbols)

See Search History document

Documentation searched other than minimum documentation to the extent that such documents are included in the fields searched

See Search History document

Electronic data base consulted during the international search (name of data base and, where practicable, search terms used)

See Search History document

C. DOCUMENTS CONSIDERED TO BE RELEVANT

Category*	Citation of document, with indication, where appropriate, of the relevant passages	Relevant to claim No.
A	US 2015/0129666 A1 (TEGO, INC.) 14 May 2015; the entire document	1-20
A	WO 2017/046699 A1 (KING ABDULLAH UNIVERSITY OF SCIENCE AND TECHNOLOGY) 23 March 2017; the entire document	1-20
A	WO 2006/07667 A2 (BERSON, W) 20 July 2006; the entire document	1-20

Further documents are listed in the continuation of Box C.

See patent family annex.

* Special categories of cited documents:	"T" later document published after the international filing date or priority date and not in conflict with the application but cited to understand the principle or theory underlying the invention
"A" document defining the general state of the art which is not considered to be of particular relevance	"X" document of particular relevance; the claimed invention cannot be considered novel or cannot be considered to involve an inventive step when the document is taken alone
"D" document cited by the applicant in the international application	"Y" document of particular relevance; the claimed invention cannot be considered to involve an inventive step when the document is combined with one or more other such documents, such combination being obvious to a person skilled in the art
"E" earlier application or patent but published on or after the international filing date	"&" document member of the same patent family
"L" document which may throw doubts on priority claim(s) or which is cited to establish the publication date of another citation or other special reason (as specified)	
"O" document referring to an oral disclosure, use, exhibition or other means	
"P" document published prior to the international filing date but later than the priority date claimed	

Date of the actual completion of the international search

10 Decemeber 2019 (10.12.2019)

Date of mailing of the international search report

06 JAN 2020

Name and mailing address of the ISA/US

Mail Stop PCT, Attn: ISA/US, Commissioner for Patents
P.O. Box 1450, Alexandria, Virginia 22313-1450
Facsimile No. 571-273-8300

Authorized officer

Shane Thomas

Telephone No. PCT Helpdesk: 571-272-4300