

Aug. 13, 1935.

C. WANTZ

2,011,097

AUTOMATIC LIGHTER

Filed Aug. 12, 1932

2 Sheets-Sheet 1

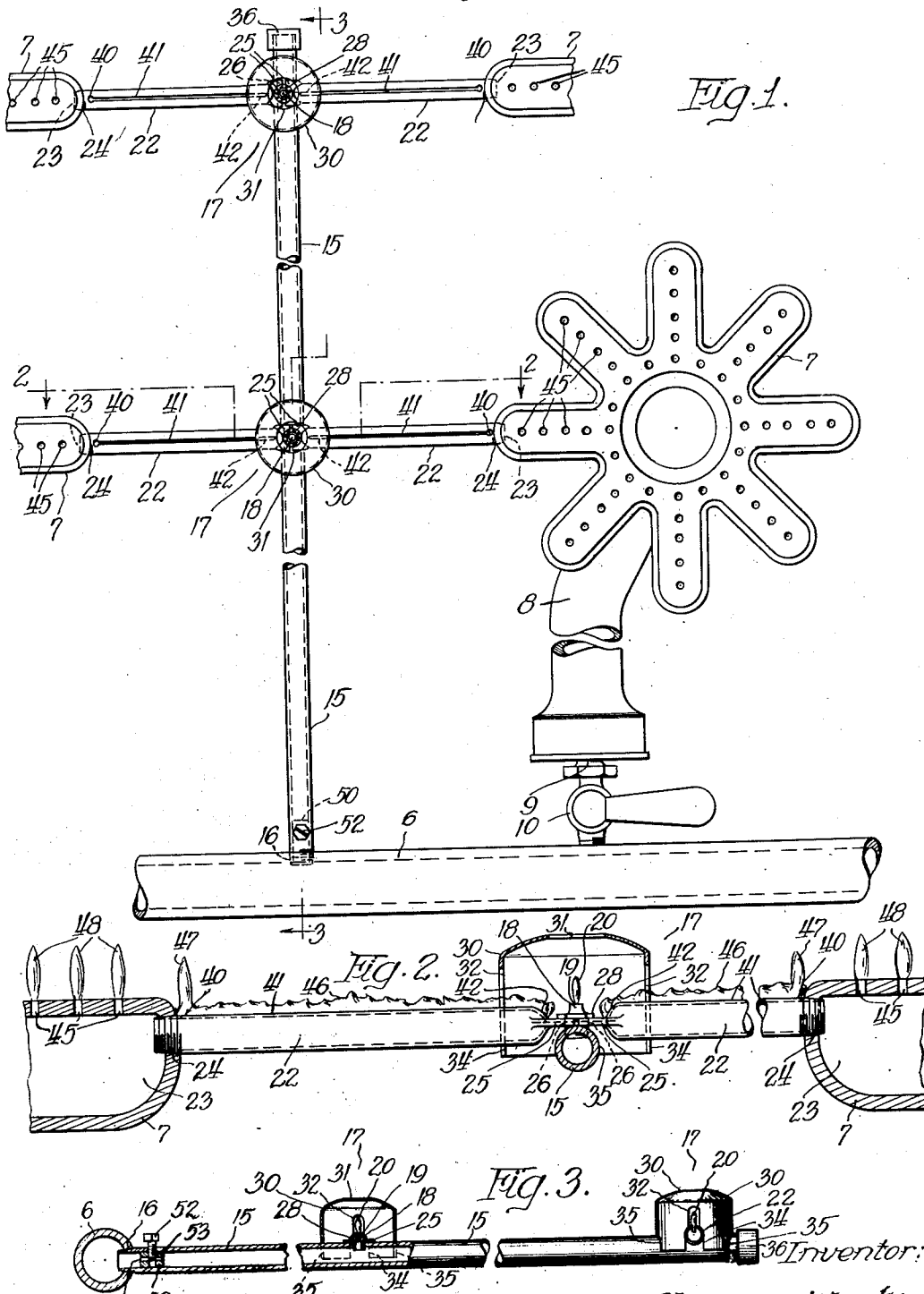

Fig. 1.

Fig. 2.

Fig. 3.

Inventor:

Clarence Wantz

By *Drown, Jackson, Dettler & Niemer*

Aug. 13, 1935.

C. WANTZ

2,011,097

AUTOMATIC LIGHTER

Filed Aug. 12, 1932

2 Sheets-Sheet 2

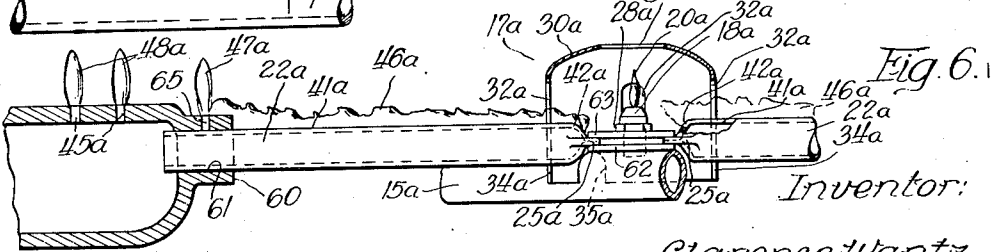
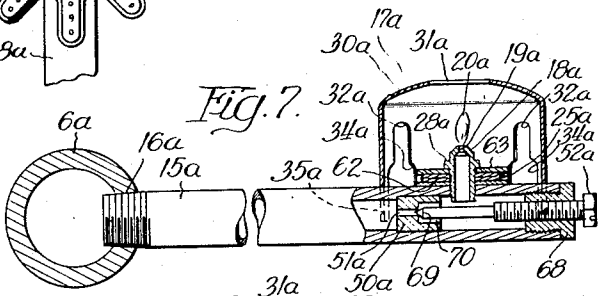
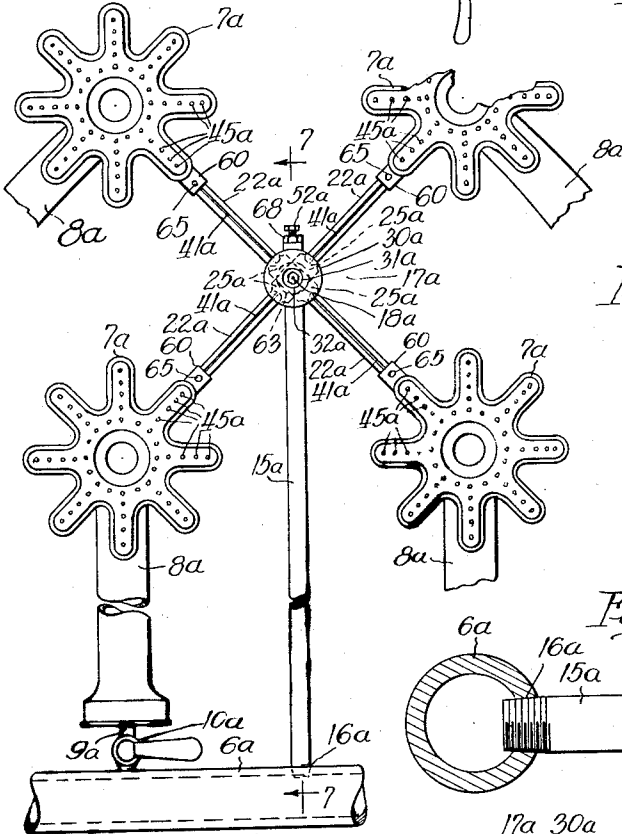
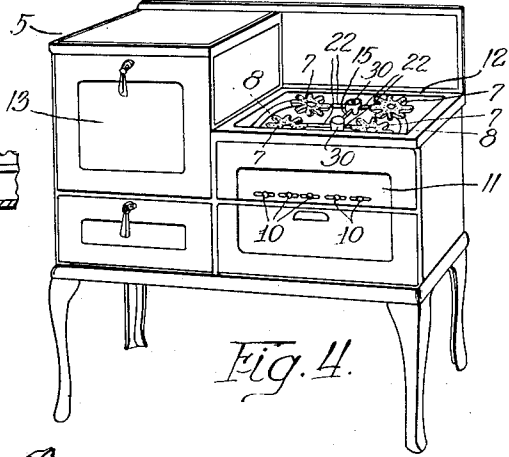
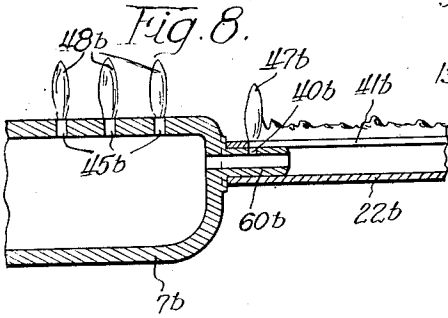

Inventor:
 Clarence Wantz.
 By *Drown, Jackson, Dutcher + Niemer* Attys

UNITED STATES PATENT OFFICE

2,011,097

AUTOMATIC LIGHTER

Clarence Wantz, Milwaukee, Wis., assignor to
Milwaukee Gas Specialty Company, Milwaukee,
Wis., a corporation of Wisconsin

Application August 12, 1932, Serial No. 628,475

21 Claims. (Cl. 158—115)

My invention relates to lighters for gas burners, and contemplates an improved lighter which will produce satisfactory results under all conditions, particularly a lighter which will operate to re-ignite a burner from the simmering position, as well as from other positions, and a lighter which will operate free from carbon monoxide, and at elevated and reduced gas pressures.

The present invention has to do particularly with lighters of the automatic or gravity type as distinguished from the push button type of lighter, it being well known that in lighters of the automatic type operating under the gravity principle when the burner is opened or when the burner flame is extinguished with the burner in open position, a flow of gas passes from the burner to the pilot flame of the lighter and the flame is conveyed from the pilot flame to the burner to light or to re-ignite the same.

My invention is illustrated in the accompanying drawings, in which:

Figure 1 is a plan view of an arrangement embodying my invention;

Figure 2 is a vertical section taken substantially on the line 2—2 of Figure 1 through one of the lighter hoods of the arrangement of Figure 1, and showing the lighter tubes in elevation and portions of the burners at the outer ends of these tubes in section;

Figure 3 is a vertical section, partially in elevation and taken on the line 3—3 of Figure 1;

Figure 4 is a perspective view of a gas range with the lighter arrangement of Figures 1 to 3 applied thereto;

Figure 5 is a plan view of another arrangement embodying my invention;

Figure 6 is a vertical section through the lighter hood of the embodiment of Figure 5, and showing the lighter tubes in elevation, with one of these tubes partially broken away and a portion of the burner at the outer end of the other tube in section;

Figure 7 is a vertical section, partially in elevation and taken on the line 7—7 of Figure 5; and

Figure 8 is a fragmentary view showing another manner of supporting the outer ends of the lighter tubes on the burners.

Referring to the drawings, a typical gas range is designated in its entirety at 5 in Figure 4. In the embodiment of Figures 1 to 4 the usual gas manifold is illustrated at 6. The gas burners are illustrated at 7, these burners 7 being fed from the manifold 6 by the usual feed pipes 8, to which air is admitted, in the usual manner, at the ends

nearest the manifold 6. The gaseous fuel is led into the feed pipes 8 by way of the nozzle pipes 9, in which nozzle pipes 9 the usual gas cocks 10 are provided.

The range shown is of the cabinet type in which the gas cocks 10, for the top and oven burners, are arranged along a panel 11 at the front of the range, with the valves, mixing chambers, and piping concealed, and only the handles of the gas cocks 10 exposed. The portion 12 of the range is utilized for the open top burners, and an oven is indicated at 13, this oven being provided with an oven burner, not shown.

The lighter comprises a feeder tube 15 threaded into the manifold at 16, this tube 15 leading from the manifold 6 and being provided with two torch heads 17, 17, one between and in appropriate proximity to the front pair of burners 7, 7, and the other between and in appropriate proximity to the rear pair of burners 7, 7. At each torch head 17 the tube 15 has an upwardly directed threaded opening in which a pilot tip 18 is threaded. Each tip 18 has a relatively restricted tip port or orifice 19 for maintaining the desired pilot flame 20.

Lighter tubes 22 lead from the feeder tube 15 to the respective burners 7, the tubes 22 for the front burners being disposed in alignment and at substantially right angles to the tube 15, with one of the tubes 22 extending from each of the opposite sides of the tube 15. The tubes 22 for the rear burners 7 are similarly arranged. The outer end of each tube 22 opens into the interior 23 of the adjacent burner 7, and is threaded into the body of the burner at 24. The opposite end of each tube is flattened at 25 by forming or swaging together the sides of the tube to close the ends of the tube and form flat supports therefor. These flattened ends 25 rest upon the feeder tube 15, and are notched or indented at 26 to receive the threaded portions of the pilot tips 18, the tips 18 being provided with integral flanges 28 between which and the tube 15 the flattened ends 25 are firmly clamped upon threading the tips 18 into place. The engagement of the threaded portions of the tips 18 in the notches or indentations 26 holds the adjacent ends of the tubes 22 firmly against lateral displacement.

A protecting hood 30 is mounted over each pilot tip 18. Each hood 30 has a vent opening 31 at the top, and two lighter flame slots 32 in the circular side wall in line with the respective burners 7 on the range. The lower ends of the slots 32 are enlarged at 34 to fit over the lighter tubes 22 as shown in Figure 3, and adjacent the feeder

tube 15 the lower edge of the side wall of the hood has slots 35 fitting down over the tube 15 as shown in Figures 2 and 3. The outer or free end of the feeder tube 15 is closed by a cap member 36 threaded or otherwise suitably secured thereon, and preferably removable from the tube.

Adjacent or just short of the threaded end 24 each lighter tube 22 has an upwardly opening lighter port 40 in its top wall, and extending longitudinally along the top of each tube 22 is a lighter slot 41. The torch head ends of these slots 41 extend at 42 down around the rounded ends of the tubes 22 to the flattened portions 25. The rounding of the ends of the tubes 22 adjacent the pilot tip 18, and the extension of the adjacent ends of the lighter slots 41 down along the rounded ends to the flattened portions 25, causes the air and gas mixture which enters the tubes 22 from the manifold is supplied to the burners 7, when the gas from the cock or cocks 10, to escape in close proximity to the pilot flame 20. This assures, under all conditions, ignition of the air and gas mixture which issues from the lighter slot 41 and lighter port 40, and ignition of the gas issuing from the ports 45 of the burners 7 under all conditions, and particularly with the burner or burners in simmering position, as well as in all other positions, and at elevated and reduced gas pressures. The extension of the lighter slots 41 down along the ends of the lighter tubes 22 and into close proximity to the torch head is an important aspect of the present invention.

When a burner 7 is to be ignited, the cock 10 associated with that burner is opened and the gaseous fuel or air and gas mixture enters the burner ready to be ignited at the burner ports 45. The air and gas mixture passes from the burner into the tube 22 and escapes from the ports 40, 41. The gas or gas and air mixture escaping from the end of the slot 41 in close proximity to the torch head is ignited by the constantly burning and relatively restricted pilot flame 20. The flame is extended or conveyed back at 46 along the slot 41 to the burner end of the tube 22, producing the flame 47 at the enlarged port 40, which in turn produces the flame 48 at the adjacent burner port or ports 45, thereby furnishing ignition to the burner. Similarly, in case the burner is unintentionally extinguished when the gas cock therefor is in simmering or any other position, the gas and air mixture will enter the tube 22 and escaping along the slot 41, and particularly from the down-turned torch head end of the slot 41, will be ignited by the pilot flame 20, and the flame will be conveyed back to re-ignite the burner as above described. The lighter tubes 22, in function, comprise a part of the respective burners, and with a properly adjusted gas and air supply will burn with a non-luminous flame, producing no CO or carbon depositions.

At the end of the feeder tube 15, near the manifold 6, an adjuster bushing 50 is provided. This bushing 50 is pressed into the interior or bore of the tube 15, so that its outer periphery has a gas-tight fit with the bore of the tube, and extending axially through the bushing there is a relatively restricted port or passageway 51. A pilot flame adjusting screw 52 is threaded or passes diametrically through the feeder tube 15 and is threaded into the bushing 50 at 53 to be projected into or withdrawn more or less from the port or passage 51 for the purpose of metering or adjusting the quantity of gas which passes from the manifold

6 to the pilot tips 18 to control, at will, the pilot flames 20. The inner end of the screw 52 may be formed as shown, or it may be of needle-point or other desired form, and this screw enables supplying diminutive quantities of gas to the pilot tips and controlling of the pilot flames 20 as pointed out above.

The embodiment of Figures 5, 6 and 7 is identical in performance with the preceding embodiment, and differs only in mechanical arrangement. In this case the lighter has a single torch head 17a. The feeder tube 15a is threaded at 16a into the manifold 6a as before. The lighter tubes 22a instead of being arranged at right angles to the tube 15a extend radially from the single torch head 17a to the respective burners 7a. The burners 7a have integral bosses 60 provided with openings 61 opening into the interior of the respective burners 7a. The burner ends of the tubes 22a fit telescopically in the openings 61 in the bosses 60, which bosses form female supports for the burner ends of the tubes, which tubes open into the interiors of the burners as before. The torch head ends of the tubes 22a are flattened together at 25a, as before, and a disc or washer 62 supported on the tube 15a has a perforation through which passes the threaded portion of the pilot tip 18a, which is threaded into the feeder tube 15a as in the preceding embodiment. The disc 62 provides adequate support for the radially disposed flat ends 25a of the tubes 22a, and a similar washer 63 overlies these flattened ends 25a. The threaded portion of the tip 18a also passes through an aperture in the center of the disc 63, and the tip 18a has an integral flange 28a which, upon threading the tip tightly into place, engages the top of the upper disc 63 and clamps the flattened ends 25a tightly between the discs 62 and 63 and the discs and torch head ends of the tubes 22a firmly in place upon the tube 15a.

The tip 18a has the relatively restricted tip port or orifice 19a for maintaining the desired pilot flame 20a, and the protecting hood 30a is mounted over the tip. This hood has a vent opening 31a at the top, and four lighter flame slots 32a are provided in the circular wall of the hood in line with the respective burners 7a. The lower ends of the slots 32a are enlarged at 34a to fit over the lighter tubes 22a, and adjacent the feeder tube 15a the lower edge of the side wall of the hood has slots 35a fitting down over this tube. The lighter ports at the burner ends of the tubes 22a open upwardly through the bosses 60 at 65 to produce the lighter flames 47a, which in turn produce the burner flames 48a at the adjacent burner ports 45a, whereby the burner is lighted or re-ignited as before. In this case the lighter slots 41a extend through the burner ends of the tubes 22a, and at their opposite ends extend, as before, down along the rounded or down-formed ends 42a of the tubes 22a and into close proximity to the constantly burning pilot flame 20a.

In this embodiment of the invention, the adjuster bushing 50a is positioned adjacent the torch head end of the tube 15a, being pressed into the interior or bore of the tube 15a so that its outer periphery has gas-tight fit with the bore of the tube. An adjuster plug 68 is threaded into the outer end of the tube 15a, and the pilot flame adjusting screw 52a is threaded axially through this plug 68. The needle-point end 69 of the adjusting or metering screw 52a cooperates with the relatively restricted port 51a to meter or adjust the quantity of gas which passes

from the manifold 6a to the pilot tip 18a, this metering or adjustment being accomplished by turning the screw 52a to move the needle-point end 69 into or away from the port 51a. The bushing 50a is counter-bored at its outer end at 70.

The operation of the embodiment of Figures 5, 6 and 7 is substantially identical with the operation of the preceding embodiment, and, therefore, the description of the same will not be repeated.

In the embodiment of Figure 8 the burner shown fragmentarily at 7b has the burner ports 45b as before, but instead of the female supports afforded for the burner ends of the lighter tubes by the bosses 60 of the preceding embodiment, the bosses 60b of this embodiment are reduced in size to fit tightly into the outer ends of the tubes 22b, thereby affording male support for the adjacent end of the lighter tube 22b, which has the longitudinal lighter slot 41b, and the boss 60b has the lighter port 40b for producing the lighter flame 47b. Should the burner become damaged because of removal or damage to the tube 22b, the burner will operate without the burner lighter in nearly the normal way.

I do not intend to be limited to the precise details shown or described.

I claim:

1. In combination, a pilot tip, and a lighter tube having an end turned down adjacent said tip for clamping said tube to said tip, said lighter tube having a lighter slot extending longitudinally along the top of the tube and down along the down-turned end of the tube into close proximity to said tip.

2. In combination, a burner, a pilot tip, a lighter tube having an end turned down adjacent said tip, said lighter tube having a lighter slot extending longitudinally along the top of the tube and down at one end along the downturned end of the tube into close proximity to said tip, and means carried by said tip for clamping said downturned end of said tube thereto, said tube having a lighter port at the opposite end of said lighter slot and in close proximity to said burner.

3. In combination, a pilot tip, and a lighter tube, said tube being swaged to flattened form at one end with the top of the tube turned down to the flattened end, said end extending about and being engaged by said tip, said tube having a lighter slot extending down along the down-turned end of the tube and into close proximity to said tip.

4. In combination, a feeder tube, a pilot tip on said tube, a burner, and a lighter tube having support at one end on said burner and at the opposite end on said feeder tube, said lighter tube having an end turned down adjacent the pilot tip and provided with a lighter slot extending along the tube and down along the down-turned end of the tube into close proximity to said tip.

5. In combination, a feeder tube, a pilot tip on said tube, and a lighter tube having support on said feeder tube and clamped to said tube by said tip.

6. In combination, a feeder tube, a pilot tip threaded in said tube, and a lighter tube having an end down-turned and flattened, said flattened end having support upon said feeder tube and clamped to said tube by said tip, the down-turned end of said lighter tube having a lighter slot in close proximity to said tip.

7. In combination, a feeder tube, a pilot tip on said tube, and a pair of lighter tubes arranged in alignment and at right angles to the feeder tube with their adjacent ends flattened and supported

upon said feeder tube and clamped to said tube by said tip.

8. In combination, a feeder tube, a pilot tip on said tube, a pair of lighter tubes arranged in alignment and at right angles to the feeder tube with their adjacent ends flattened and supported upon said feeder tube and clamped to said tube by said tip, the lighter tubes having lighter slots turned down at the feeder tube ends into close proximity to said tip, and a hood mounted over said tip and having lighter frame slots in alignment with the lighter slots in the tubes, the lower ends of said lighter flame slots being enlarged to fit over said lighter tubes.

9. In combination, a feeder tube, a pilot tip on said tube, a plate held in position upon the feeder tube by said tip, a plurality of lighter tubes disposed radially with respect to said tip and having flattened ends supported upon said plate, and a second plate overlying the flattened ends of said lighter tubes and clamped in place by said tip.

10. In combination, a burner, a torch head, a lighter tube extending from said torch head toward the burner, and a hood for said torch head, said hood having a lighter flame slot directed toward the burner, and the bottom of said slot being enlarged to fit over the lighter tube.

11. In combination, a feeder tube, a pilot tip on said tube, a burner, a lug extending laterally from the side of the burner, and a lighter tube having one end engaged with said lug for support upon the burner, said lighter tube having means engageable between said pilot tip and feeder tube for supporting the opposite end of said lighter tube.

12. In combination, a feeder tube, a pilot tip on said tube, a burner, and a lighter tube threaded at its burner end into the side of the burner and being clamped at its opposite end between said pilot tip and said feeder tube.

13. In combination, a feeder tube, a pilot tip on said tube, a burner, a hollow boss extending laterally from the side of the burner, and a lighter tube having telescoping engagement at its burner end with said hollow boss and being clamped at its opposite end between said pilot tip and said feeder tube.

14. In combination, a feeder tube, a plurality of burners, a plurality of torch heads along the feeder tube for the respective burners comprising pilot tips threaded into said feeder tube, lighter tubes extending from one torch head to certain burners, and other lighter tubes extending from another torch head to other burners, said lighter tubes being clamped between said pilot tips and said feeder tube.

15. In combination, a burner, means for supplying gaseous fuel to the burner, a feeder tube, a torch head on said tube, said torch head including a pilot tip, a lighter tube clamped between said pilot tip and said feeder tube and extending from said torch head to said burner for conveying gaseous fuel from the burner to the torch head and a flame from the torch head to the burner, and means for adjusting the fuel supply to said pilot tip independently of the fuel supply to the burner.

16. In combination, a burner, means for supplying gaseous fuel to the burner, a feeder tube, a torch head on said tube, said torch head including a pilot tip, a lighter tube clamped between said pilot tip and said feeder tube and extending from said torch head to said burner for conveying gaseous fuel from the burner to the torch head and a flame from the torch head

- to the burner, and means for adjusting the fuel supply to said pilot tip independently of the fuel supply to the burner, said means comprising an adjuster bushing in the feeder tube, and a pilot adjusting screw cooperating with a port in said bushing.
17. In combination, a burner, means for supplying gaseous fuel to the burner, a feeder tube, a torch head on said tube, said torch head including a pilot tip, a lighter tube clamped between said pilot tip and said feeder tube and extending from said torch head to said burner for conveying gaseous fuel from the burner to the torch head and a flame from the torch head to the burner, and means for adjusting the fuel supply to said pilot tip independently of the fuel supply to the burner, said means comprising an adjuster bushing in the feeder tube, and a pilot adjusting screw cooperating with a port in said bushing, said adjusting screw being mounted in an adjuster plug threaded in the outer end of the feeder tube.
18. In combination, a burner, a feeder tube, a pilot tip on said feeder tube, and a lighter tube supported at one end on said burner and having its other end clamped between said pilot tip and said feeder tube.
19. In combination, a burner, a feeder tube, a pilot tip thereon, a port in the side wall of said burner, and a lighter tube extending from said burner port to said pilot tip, one end of said lighter tube being flattened and clamped between said tip and said feeder tube.
20. In combination, a feeder tube, a pilot tip threaded into said feeder tube, and a lighter tube having its end flattened and clamped between said tip and said feeder tube, said lighter tube having a longitudinal slot extending along its upper surface into proximity to said tip.
21. In combination, a feeder tube, a pilot tip threaded therein, a hood for said pilot tip supported on said feeder tube and having openings in the side walls thereof, and lighter tubes extending from said tip outwardly through said openings, the inner ends of said tubes being flattened for clamping said ends between said tip and said feeder tube.

CLARENCE WANTZ.