

June 30, 1925.

1,543,861

W. W. McCORD

METHOD OF AND APPARATUS FOR PRODUCING COPPER SHEETS ELECTROLYTICALLY

Filed May 16, 1924

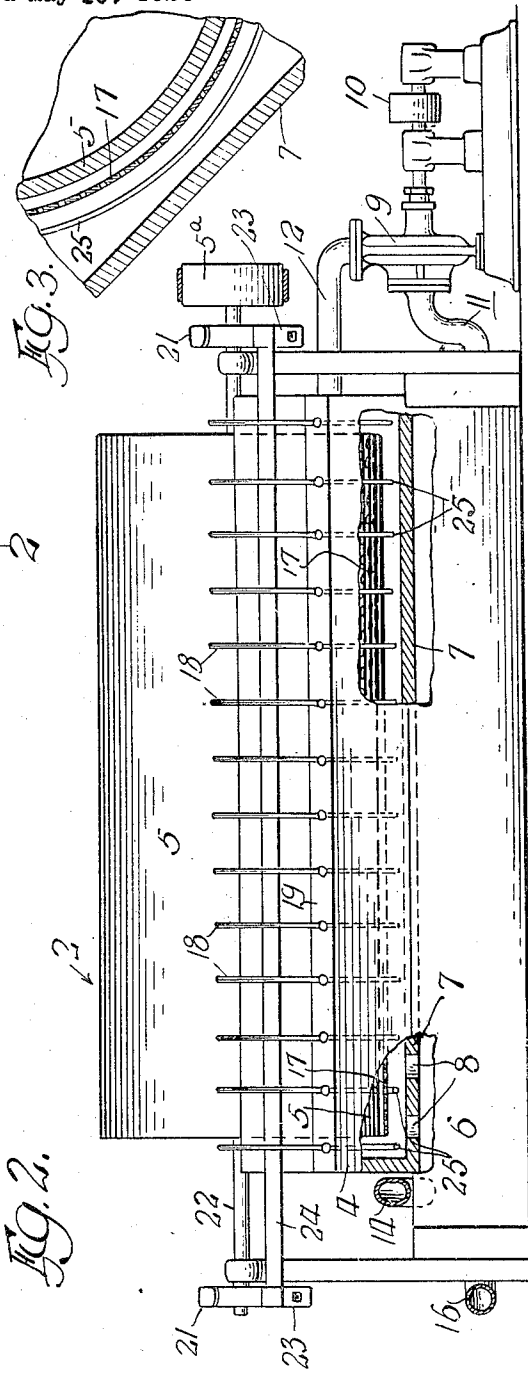
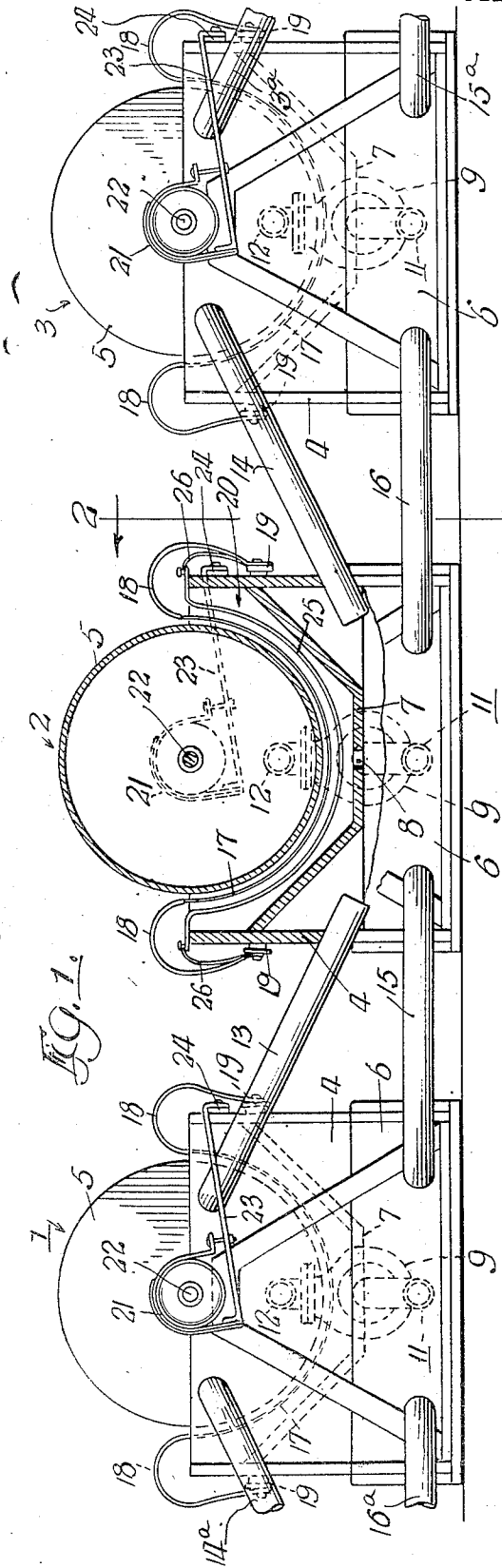

Inventor
William W. McCord
By Eugene C. Swan
Atty.

UNITED STATES PATENT OFFICE.

WILLIAM W. McCORD, OF WYANDOTTE, MICHIGAN, ASSIGNOR TO McCORD RADIATOR & MFG. CO., OF DETROIT, MICHIGAN, A CORPORATION OF MAINE.

METHOD OF AND APPARATUS FOR PRODUCING COPPER SHEETS ELECTROLYTICALLY.

Application filed May 16, 1924. Serial No. 713,668.

To all whom it may concern:

Be it known that I, WILLIAM W. McCORD, a citizen of the United States, residing at Wyandotte, in the county of Wayne and State of Michigan, have invented new and useful Improvements in Methods of and Apparatus for Producing Copper Sheets Electrolytically, of which the following is a specification.

This invention relates to an electro-depositing method and apparatus, and consists in the matters hereinafter described and claimed.

In the accompanying drawings—

Fig. 1 is a front view with parts in section of an apparatus practicing my improved method;

Fig. 2 is an enlarged side view, on line 2—2 of Fig. 1, of one of the units of the apparatus; and

Fig. 3 shows a detail of construction to be hereinafter described.

In Fig. 1, I have shown three separate electro-depositing units 1, 2, and 3, connected together for electrolyte circulation in accordance with my invention. Each unit has a depositing tank 4, in which is journaled a drum or mandrel 5, on which the metal content of the electrolyte is deposited in sheet form. The tank may be made of wood with a lining of either pitch or lead. Copper sheets are produced when the electrolyte contains copper sulphate. In such connection, the copper deposited on the drums 5 is stripped off the same in sheet form in the operation of the apparatus. Each tank 4 is arranged over a storage tank 6, the dividing wall 7 between them having one or more outlet openings whereby the depositing and storage tanks have communication through said wall.

For each unit 1, 2, and 3, I provide a pump 9. Each pump 9, as shown in Fig. 2, has a pulley 10 by which it may be operated. The inlet pipe 11 of the pump is connected with the storage tank 6, while the discharge pipe 12 opens into the depositing tank 4.

Units 1 to 3 are connected together for electrolyte circulation in the following manner. The depositing tank 4 of unit 1 is connected by a pipe 13 with the storage tank 6 of unit 2. The depositing tank 4 of unit 3 is connected by a pipe 14 with the storage tank 6 of unit 2. The storage tanks 6 of the

three units are connected by pipes 15 and 16, respectively, as shown in Fig. 1.

In operation, the pump 9 of the first unit 1 draws electrolyte from its storage tank 6 and by pipes 11 and 12 delivers the same to its deposition tank 4. On passing the drum 5 in this unit, the electrolyte flows by pipe 13 to the storage tank 6 of the next unit 2, thence by pump 9 and its pipes 11 and 12 of unit 2 into its tank 4 past the drum 5 of unit 2. The electrolyte passes to the storage tank 6 of unit 2 through the outlets 8 in the wall 7 and by pipe 15 is returned to storage tank 6 of unit 1, or by pipe 16 is delivered to the storage tank 6 of unit 3. The electrolyte is pumped through unit 3 by its pump 9, past drum 5 of said unit. A return to the storage tank 6 of unit 2 may be made by pipe 14 or circulated through other units included in the system, as suggested in Fig. 1 by pipes 13^a and 14^a. These two pipes, as to the units which they connect, correspond to pipes 13 and 14, respectively.

Fig. 1 also suggests by pipes 15^a, 16^a that unit 1 is part of a system connected in circuit in accordance with my invention, said pipes corresponding to pipes 15 and 16. The units of the entire system are connected so that the electrolyte is pumped from one unit to another, and thus is given a circulating motion throughout all the units in the system, deposits being made on the drums 5 of the various units, as is manifest.

Each unit has an insoluble anode face 17 (Fig. 3), preferably a perforated lead sheet, curved to follow the contour of the drum 5 of the unit and connected by conductors 18 with the bus bars 19 on the tank 4 of the unit for current flow in accordance with the electrical hook-up in an apparatus of this kind.

Of the three units shown, the second unit 2 is the only one which is supplied with metal stock from time to time to furnish the metal content for the electrolyte for said units. When copper is the metal being deposited on the drums 5 to make sheets, scrap copper, preferably of light-gage and in small pieces as produced in making automobile and like radiators, is placed in the tank 4 of unit 2 in the space 20 to furnish copper sulphate to the electrolyte. Units 1 and 3 are not supplied with scrap metal. In each unit, its drum 5 is its cathode.

Supplying unit 2 with metal stock or scrap copper and not supplying units 1 and 3 with metal stock produces in unit 2 copper sulphate in excess of the amount that can be deposited out on the drum 5 of unit 2. Circulating the electrolyte from one unit to the other, the excess metallic content or copper sulphate is deposited out of the electrolyte on the drums of those units not supplied with metal stock. This maintains a substantially constant or even percentage of metallic content in the electrolytic bath at all times, thus keeping the electrolyte in a workable state and making the units operate at a low current cost and producing a good grade of copper on the drums. By the use of disconnected individual units as heretofore, an excess of copper sulphate produced in each unit caused the temperature to rise with a simultaneous increase in voltage at a given amperage, thus making the current cost high, and when continued long enough the copper became poorer and poorer until eventually it would adhere tightly to the drum and could not be stripped off except in small bits, making it of very little use, it being of a very brittle nature.

In accordance with my invention, by the proper proportioning of the tanks containing scrap or metal, stock to the ones not containing it and circulating the electrolyte throughout all the units included in the system, the metallic content or copper sulphate, as the case may be, is kept at an almost constant level, which makes efficient and economical the production of copper sheets by an electrolytic process. The invention allows the building up of the metallic content or copper sulphate in one part of the system and by circulation moves it to another part of the system where it is used without handling or removal of the electrolyte from the system. The proper proportioning of the tanks containing scrap to the tanks not containing scrap in order to maintain the solution cannot be laid down exactly, as it will vary according to the character of the scrap used, the percentage of acid used in the electrolyte, and whether or not the same amperage is used in all units; but this proposition can be readily determined in actual use by proper analysis of the electrolyte at intervals.

The higher the copper sulphate content in the electrolyte, the higher the gravity of the same, so that the electrolyte, by means of the horizontal pipes 15 and 16 and 15^a and 16^a will tend to equalize the copper sulphate content throughout the system, the heavier electrolyte in one unit tending to flow through and displace the lighter electrolyte in any contiguous unit.

Except as specifically claimed, I do not wish to be limited or restricted to the particular form of cathode herein shown and

described. It may be a sheet, belt, or any other convenient form from which the deposited metal may be stripped. Moreover, the cathode may be entirely submerged instead of only partially submerged as shown in the drawings. In belt form it could be passed in and out of the electrolyte by revolving or other action. Furthermore, the other details of structure shown and described may be variously changed and modified without departing from the spirit and scope of my invention.

Two collector ring and brush assemblies 21 are on each drum shaft 22 and are connected by conductors 23 with a bus bar 24 on the tank 4 of the unit. By this arrangement, each drum 5 is placed in the electrical circuit required for an apparatus of the kind described. Each drum is rotated through a pulley 5^a on its shaft.

In tank 4 of unit 2 are a plurality of copper rods 25 following under drum 5 on the same general curvature and connected by conductors 26 to the bus bars 19, 19. These rods are spaced radially from the drum and are also spaced apart laterally. By agitating the rods from side to side, either by hand or mechanically, the scrap fed into the tank 4 is prevented from matting or unduly collecting on the inclined walls of said tank to make faulty the operation of the unit. This agitating means forms the subject-matter of my copending application filed May 16, 1924. Serial No. 713,667.

I claim as my invention:

1. The process of maintaining a substantially constant percentage of metallic content in the electrolyte of an electrolytic apparatus, consisting in circulating the electrolyte through a plurality of connected electro-depositing units and supplying only certain of the units with metal stock so that the excess metallic content produced in such units will be deposited out in the units not supplied with metal stock.
2. The process of maintaining a substantially constant percentage of metallic content in the electrolyte of an electrolytic apparatus, consisting in circulating the electrolyte through a plurality of connected electro-depositing units in a manner causing the electrolyte to flow from the deposition tank of one unit into a storage tank in communication with another unit and supplying only certain of the units with metal stock so that the excess metallic content produced in such units will be deposited out in the units not supplied with metal stock.
3. The process of maintaining a substantially constant percentage of metallic content in the electrolyte of an electrolytic apparatus, consisting in circulating the electrolyte through a plurality of connected electro-depositing units and building up in one part of the circulating system the metallic

content in excess of that required for certain of the units for depositing out by other of the units.

4. The process of equalizing the electrolyte of a plurality of separate electro-depositing units of an electrolytic apparatus, consisting in having the storage and deposition tanks of the units in communication so that by circulation through them the heavier electrolyte in one unit will flow through and displace the lighter electrolyte in another unit.

5. The process of maintaining a substantially constant percentage of copper sulphate in an electrolyte of an apparatus for making copper sheets by electro-deposition, consisting in pumping the electrolyte through a circulating system in which are a plurality of separated electro-depositing units and building up the copper sulphate in one part of the system in excess of that required for such part of the system for depositing out in another part of the system.

6. The process of maintaining a substantially constant percentage of copper sulphate in an apparatus for making copper sheets by electro-deposition, consisting in circulating the electrolyte through a plurality of connected electro-depositing units and supplying copper scrap to certain of the units so that the excess copper sulphate produced at such units will be deposited out in the units not supplied with copper scrap.

7. The combination with a plurality of separate units for electro-deposition, of conduit means connecting the units together for

circulation of the electrolyte therethrough so that in supplying metal stock to certain of the units excess metal content will be produced therein for the units not supplied with metal stock.

8. The combination with a plurality of separate units for electro-deposition, each unit having connected storage and deposition tanks, of conduit means connecting the deposition tank of one unit with the storage tank of another unit for circulation of electrolyte therethrough.

9. The combination with a plurality of separate units for electro-deposition, each unit having connected storage and deposition tanks, of pipes connecting the deposition tank of one unit with the storage tank of another unit, additional pipes connecting the storage tanks of the units, and means for circulating the electrolyte through the units.

10. The combination with a plurality of separate units for electro-deposition, each unit having communicating storage and deposition tanks with a rotary cathode drum or mandrel in the latter, of a lead anode sheet in each unit under the drum therein and in electrical circuit with said drum, and conduit means connecting the deposition and storage tanks of the units for electrolytic circulation therethrough.

In testimony that I claim the foregoing as my invention, I affix my signature this 8th day of May, 1924.

WILLIAM W. McCORD.