



US00D735113S

(12) **United States Design Patent**
Schoeppner et al.

(10) **Patent No.:** **US D735,113 S**

(45) **Date of Patent:** **** Jul. 28, 2015**

- (54) **TIRE**
- (71) Applicant: **The Goodyear Tire & Rubber Company**, Akron, OH (US)
- (72) Inventors: **Nicholas Thomas Schoeppner**, Cuyahoga Falls, OH (US); **Brian David Digman**, Sagamore Hills, OH (US); **Shannon Joseph Hughes**, Rootstown, OH (US)
- (73) Assignee: **The Goodyear Tire & Rubber Company**, Akron, OH (US)

D546,272 S	7/2007	Shinohara et al.	D12/521
D551,156 S	9/2007	Shinohara et al.	D12/521
D560,595 S	1/2008	Bindner et al.	D12/521
D560,600 S	1/2008	Dixon et al.	D12/588
D568,234 S *	5/2008	Shinohara et al.	D12/521
D586,724 S	2/2009	Seibert et al.	D12/519
D586,726 S *	2/2009	Baumard et al.	D12/521
D593,931 S	6/2009	Fontaine et al.	D12/521
D597,474 S *	8/2009	Yamakawa et al.	D12/519
D606,002 S	12/2009	Yamakawa et al.	D12/519
D634,262 S *	3/2011	Kujime	D12/521
D638,348 S	5/2011	Harvey et al.	D12/521
D639,719 S	6/2011	Harvey et al.	D12/521
D639,720 S	6/2011	Harvey et al.	D12/521

(Continued)

(**) Term: **14 Years**

Primary Examiner — Stacia Cadmus

(74) *Attorney, Agent, or Firm* — Richard B. O’Planick

(21) Appl. No.: **29/444,637**

(57) **CLAIM**

The ornamental design for a tire, as shown and described.

(22) Filed: **Feb. 1, 2013**

DESCRIPTION

(51) **LOC (10) Cl.** **12-15**

(52) **U.S. Cl.**

(58) **Field of Classification Search**

USPC **D12/521**
 CPC B60C 11/0304; B60C 11/0302; B60C 11/0306; B60C 11/0309; B60C 11/0318; B60C 11/0311; B60C 11/042; B60C 11/13; B60C 11/00; B60C 11/11; B60C 11/12
 See application file for complete search history.

FIG. 1 is a perspective view of a tire showing our new design, it being understood that the pattern repeats uniformly throughout the circumference of the tread;
 FIG. 2 is a front elevational view thereof;
 FIG. 3 is a right side elevational view thereof;
 FIG. 4 is a left side elevational view thereof;
 FIG. 5 is an enlarged fragmentary front elevational view thereof;
 FIG. 6 is a perspective view of a second embodiment of a tire showing our new design, it being understood that the pattern repeats uniformly throughout the circumference of the tread; and,
 FIG. 7 is a front elevational view of a second embodiment, it being understood that an enlarged fragmentary view thereof would be substantially identical to that shown in FIG. 5, with the exception of the inclusion of the sidewall in solid lines.
 In the drawings, the broken lines showing of the sidewall, inner bead and the peripheral boundary between the tire tread and the sidewall in FIGS. 1 through 5 depict environmental subject matter and form no part of the claimed design.

(56) **References Cited**

U.S. PATENT DOCUMENTS

D418,785 S *	1/2000	Lovell et al.	D12/521
D444,428 S *	7/2001	Hutz et al.	D12/522
D451,453 S	12/2001	Maxwell et al.	D12/147
D453,919 S	2/2002	Mast et al.	D12/528
D469,396 S	1/2003	Hutson et al.	D12/520
D470,443 S	2/2003	Slingluff et al.	D12/147
D490,047 S	5/2004	Heinen et al.	D12/524
D512,013 S	11/2005	Delu et al.	D12/521
D522,442 S	6/2006	Shirouzu	D12/515
D524,231 S	7/2006	Marazzi et al.	D12/521
D524,233 S	7/2006	Marazzi et al.	D12/521

1 Claim, 7 Drawing Sheets

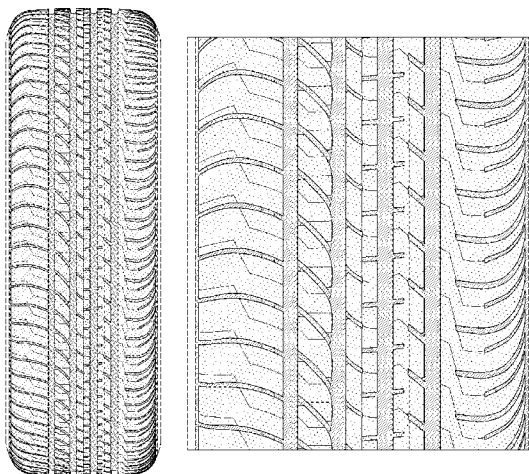

(56)

References Cited

U.S. PATENT DOCUMENTS

D644,592 S 9/2011 Grabo et al. D12/519
D647,454 S * 10/2011 Fabing et al. D12/518
D659,075 S 5/2012 Harvey et al. D12/521
D662,451 S 6/2012 Schmalix et al. D12/521

D668,598 S 10/2012 Hughes et al. D12/521
D675,149 S * 1/2013 Bruneau et al. D12/518
D684,919 S * 6/2013 Maxwell et al. D12/521
D684,920 S * 6/2013 Maxwell et al. D12/521
D710,787 S * 8/2014 Dixon et al. D12/521

* cited by examiner

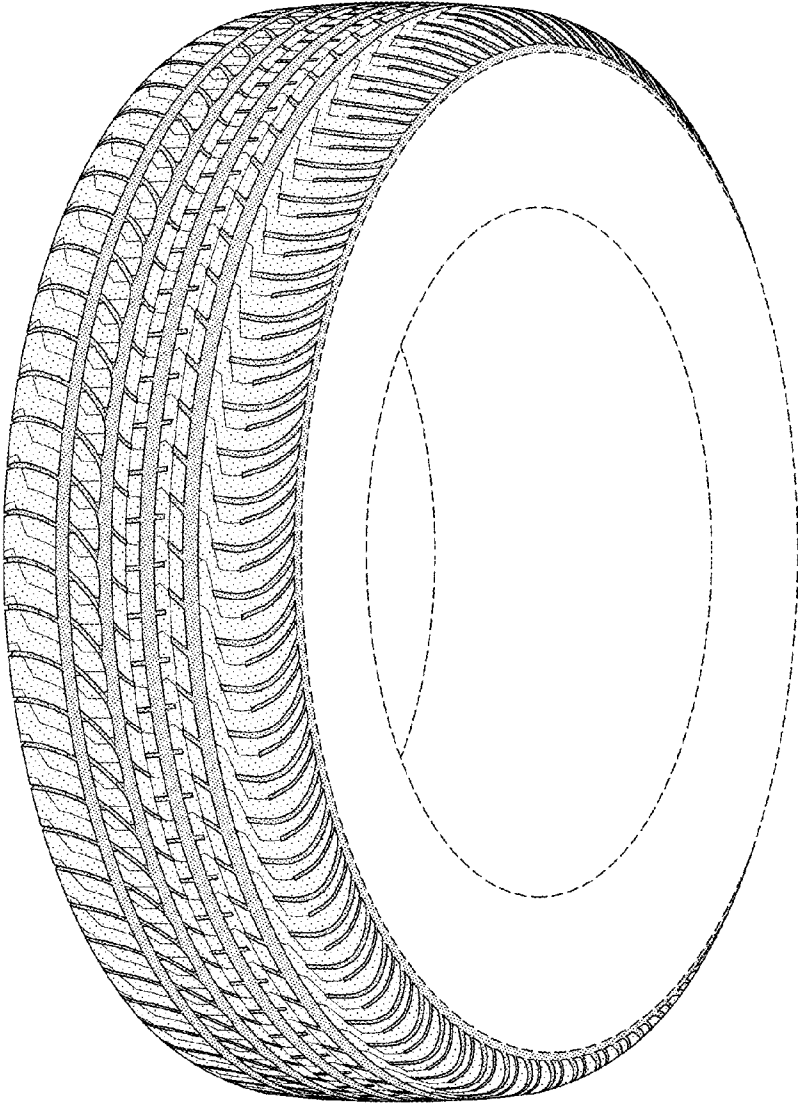

FIG-1

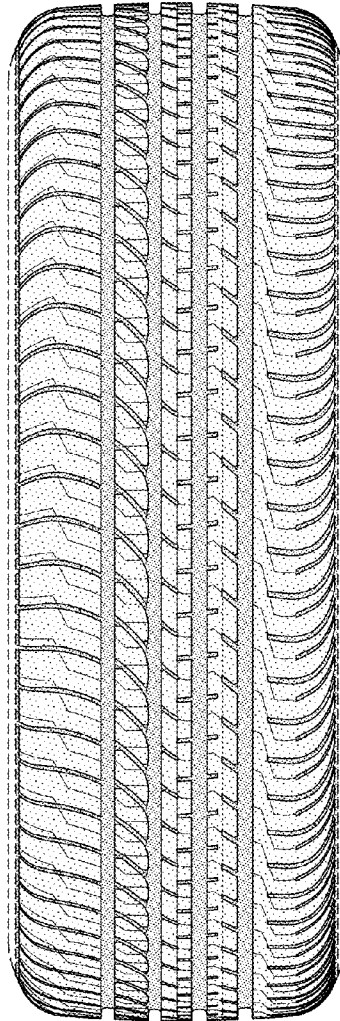

FIG-2

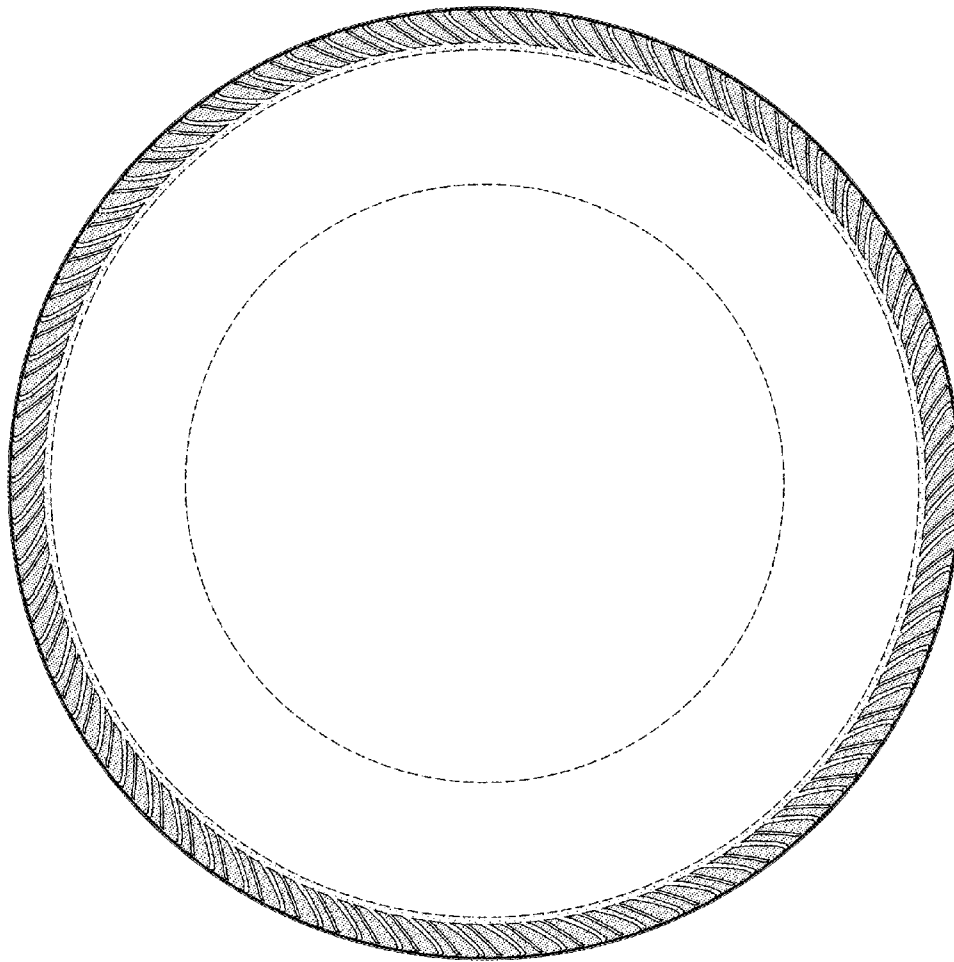

FIG-3

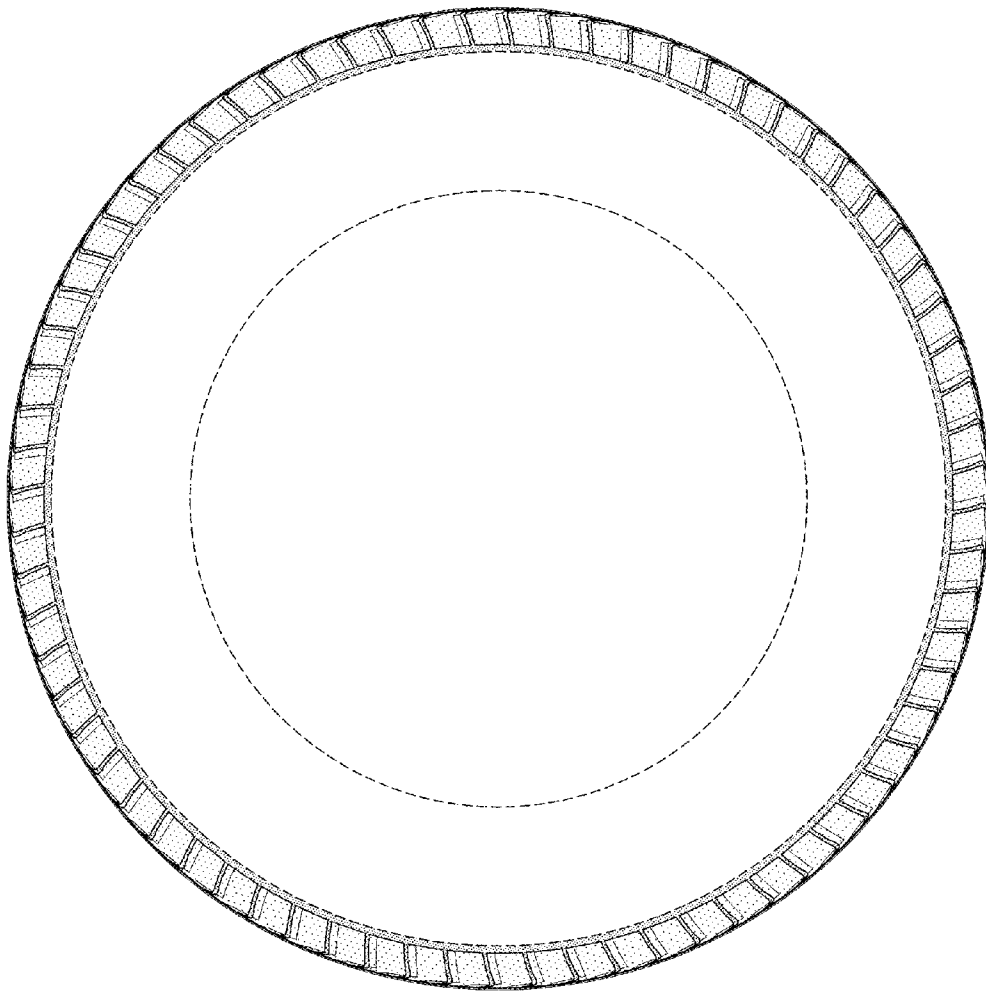

FIG-4

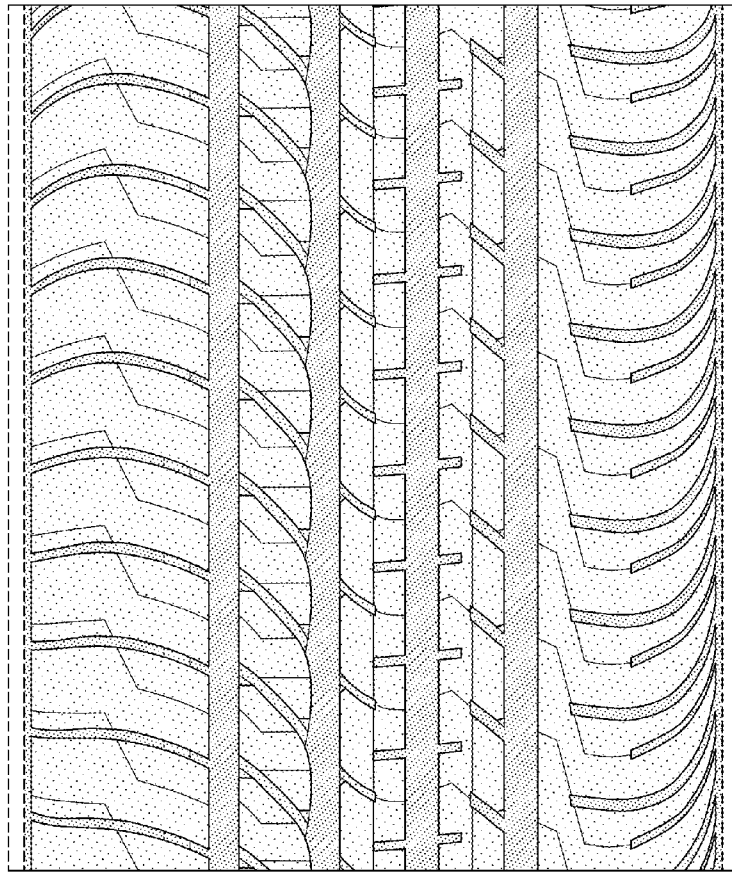

FIG-5

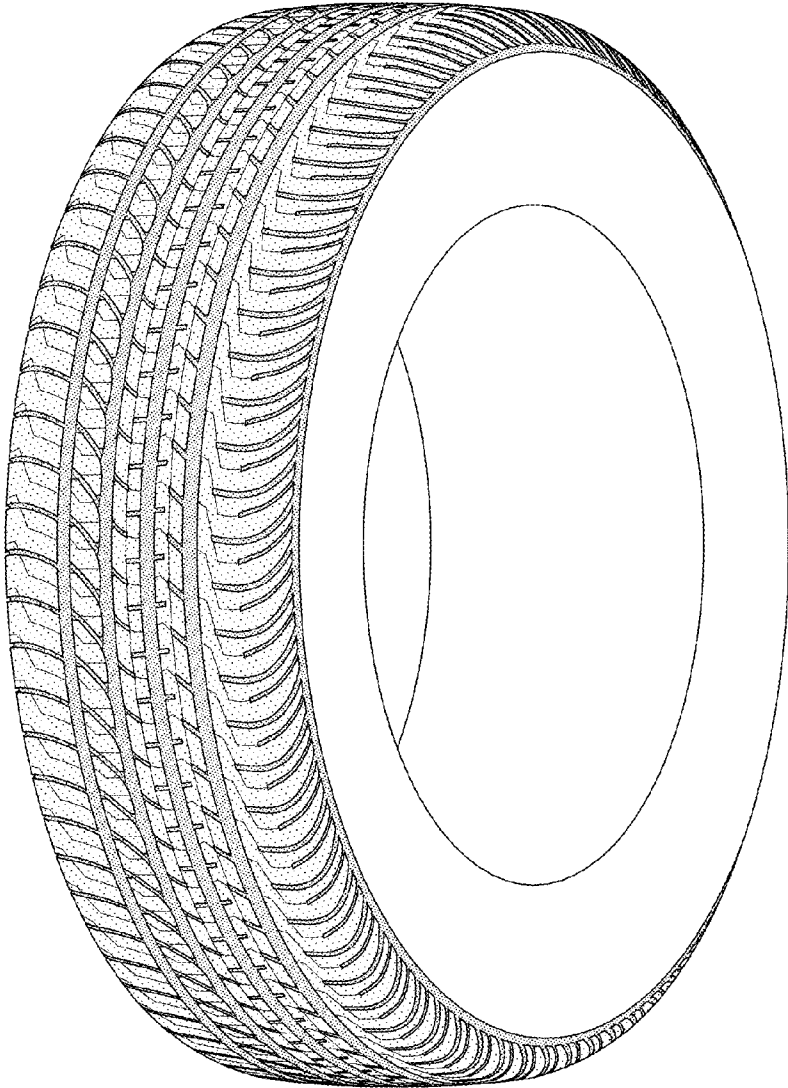

FIG-6

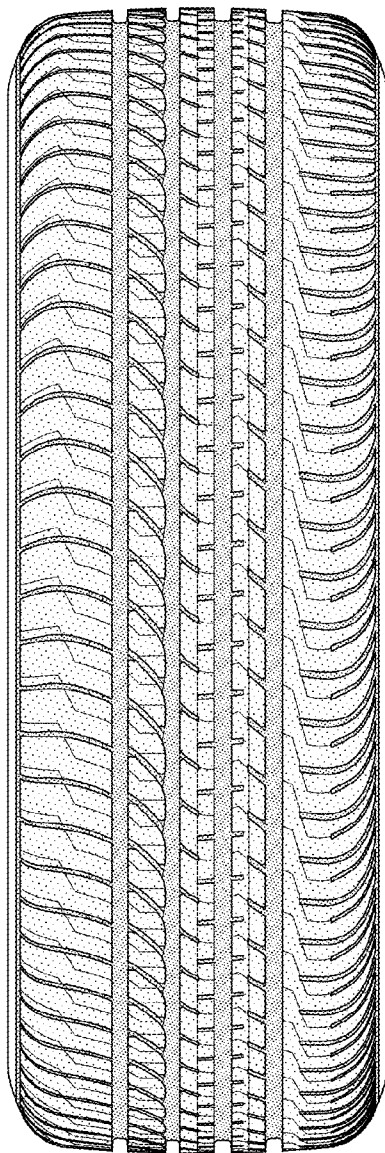

FIG-7