



US 20050279041A1

(19) **United States**

(12) **Patent Application Publication**
Staples et al.

(10) **Pub. No.: US 2005/0279041 A1**

(43) **Pub. Date: Dec. 22, 2005**

(54) **GRID PANEL STORAGE SYSTEM**

(52) **U.S. Cl. 52/506.06**

(75) **Inventors: Michael Staples, Hatboro, PA (US);
Dennis Staples, Jenkintown, PA (US)**

Correspondence Address:
VOLPE AND KOENIG, P.C.
UNITED PLAZA, SUITE 1600
30 SOUTH 17TH STREET
PHILADELPHIA, PA 19103 (US)

(57) **ABSTRACT**

(73) **Assignee: StorageTrak, LLC, Philadelphia, PA**

(21) **Appl. No.: 11/154,837**

(22) **Filed: Jun. 16, 2005**

Related U.S. Application Data

(60) **Provisional application No. 60/580,514, filed on Jun. 17, 2004.**

Publication Classification

(51) **Int. Cl.⁷ E04B 2/00**

A storage system is provided. The storage system includes a first horizontal track having an upwardly directed channel forming a first interlocking portion. A grid panel is provided including horizontal members, crossing members connected to the horizontal members, and a first hook member positioned in proximity to a top edge of the grid panel. The first hook member forms a second interlocking portion which is removably connected to the first interlocking portion of the first horizontal track. A second hook member is positioned in proximity to a bottom edge of the grid panel forming a third interlocking portion. A second horizontal track is provided having a downwardly directed channel forming a fourth interlocking portion, wherein the fourth interlocking portion is removably connected to the third interlocking portion of the grid panel. Various storage shelves, baskets, hooks or other implements are connected to the grid panel. A method for installing a storage system is also provided.

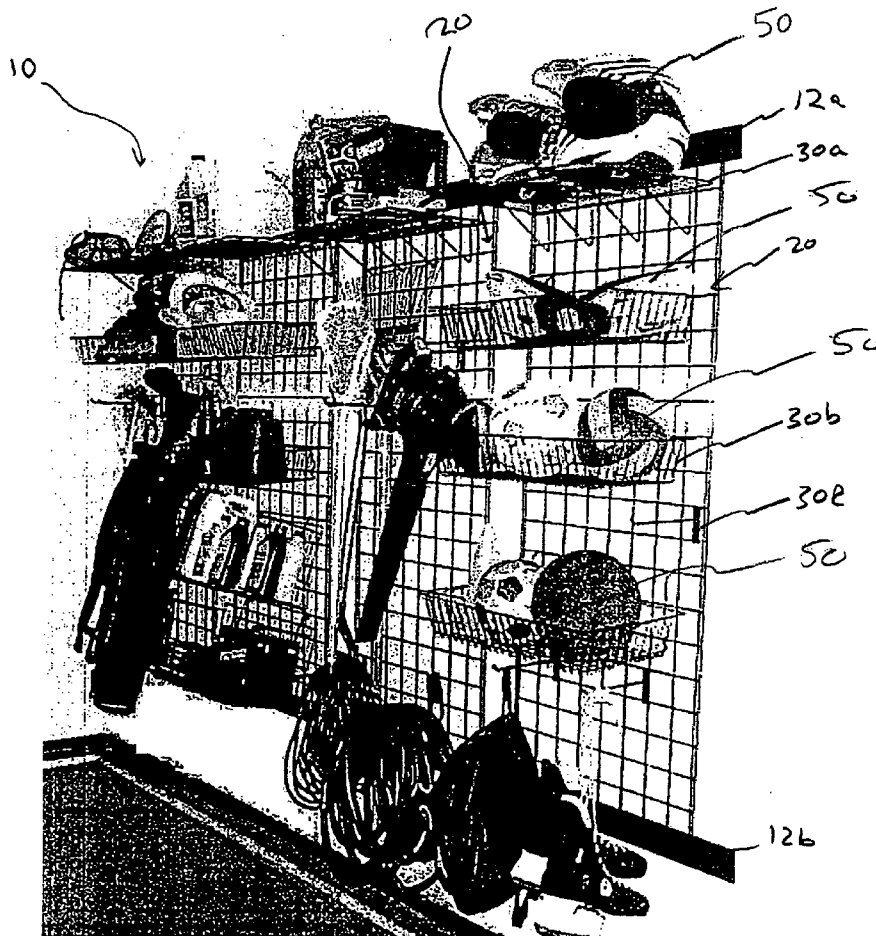

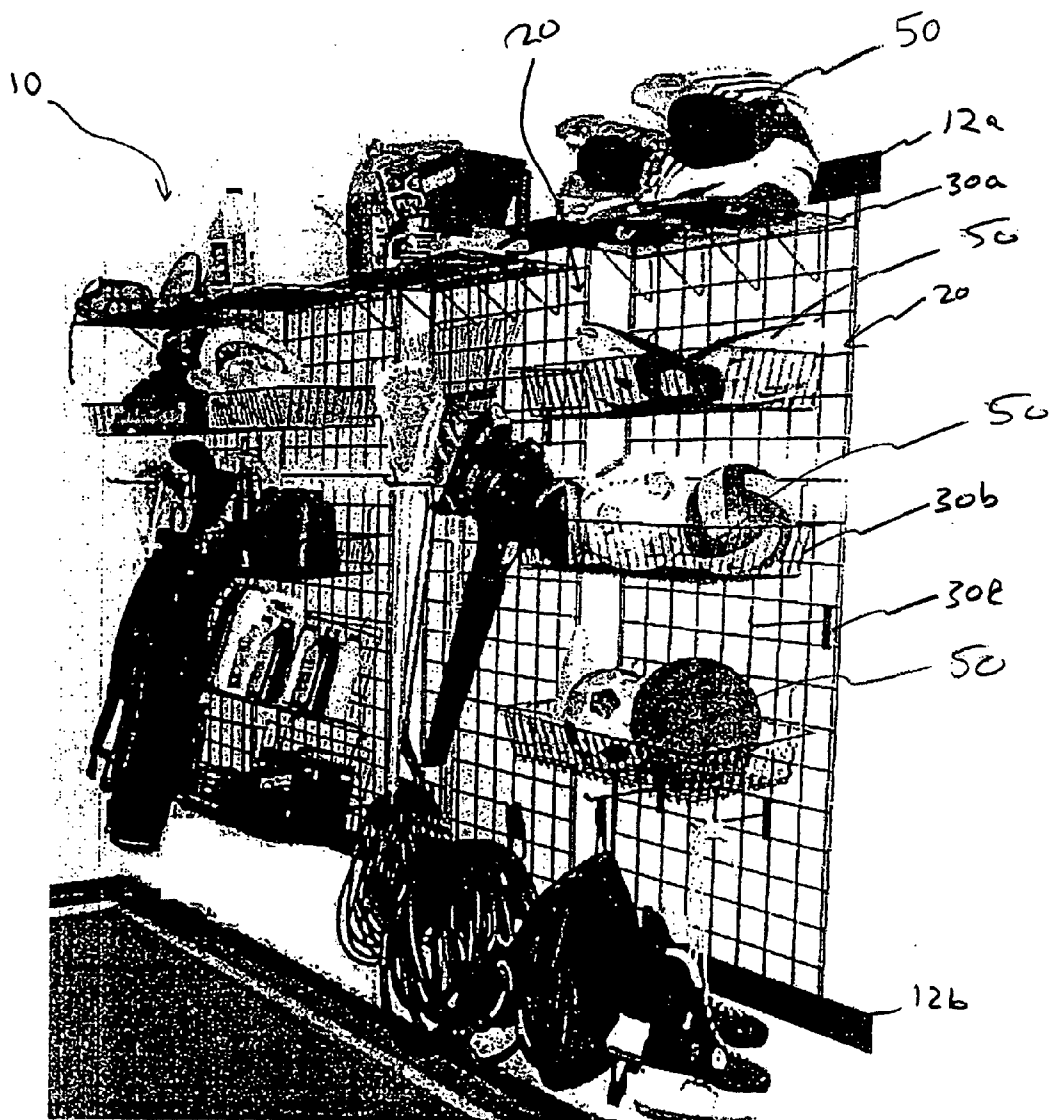

Fig. 1

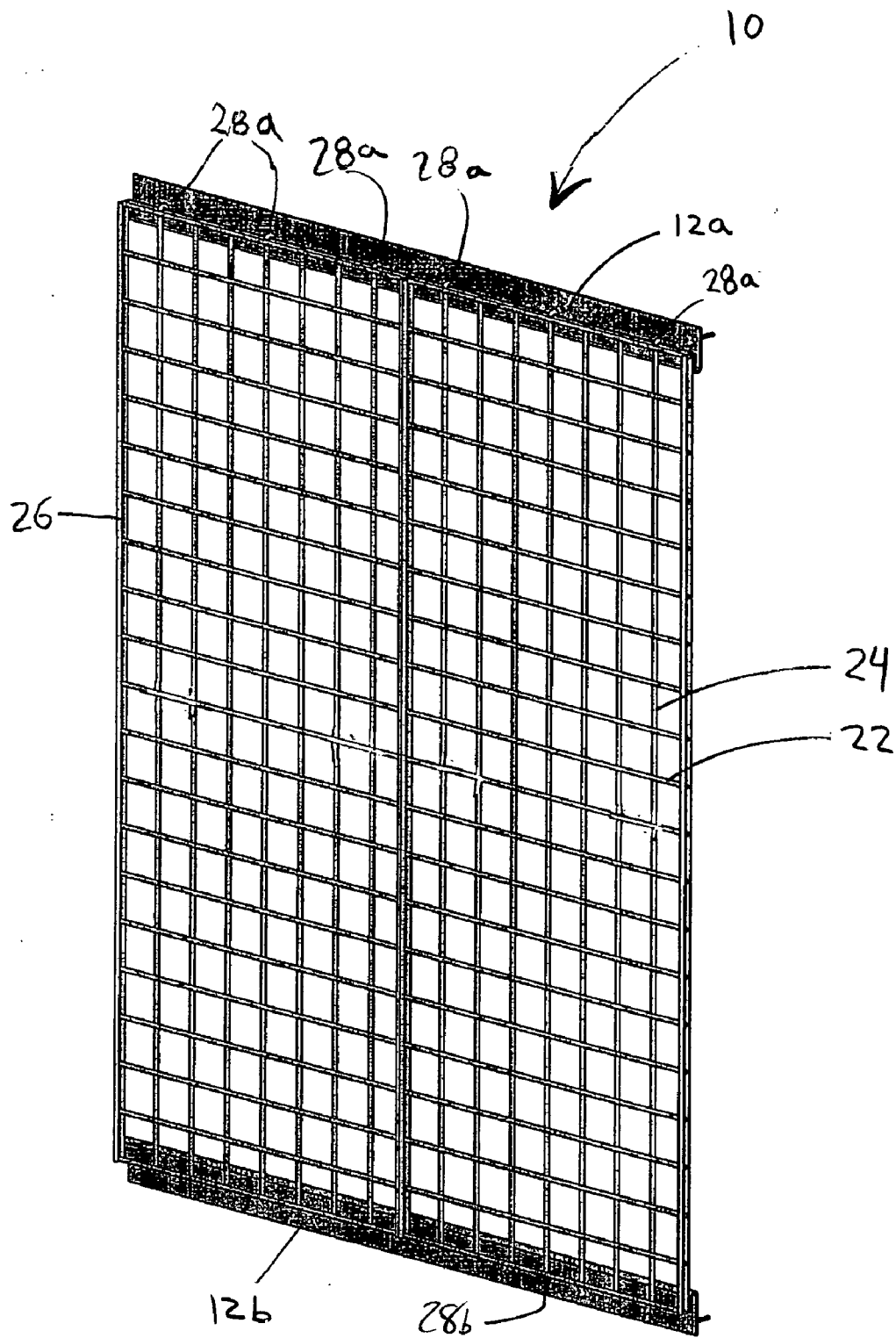

Fig. 2

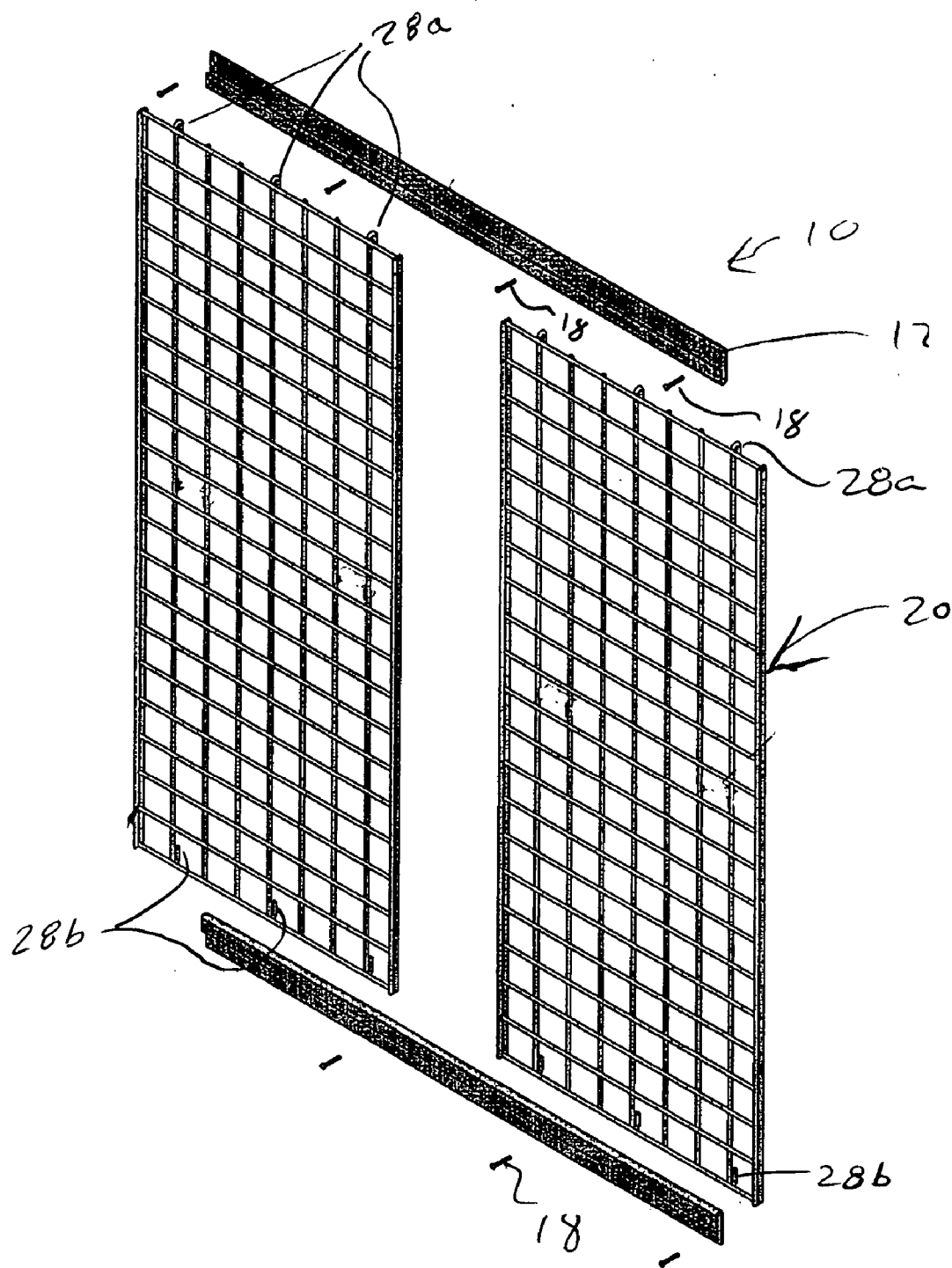

Fig. 2A

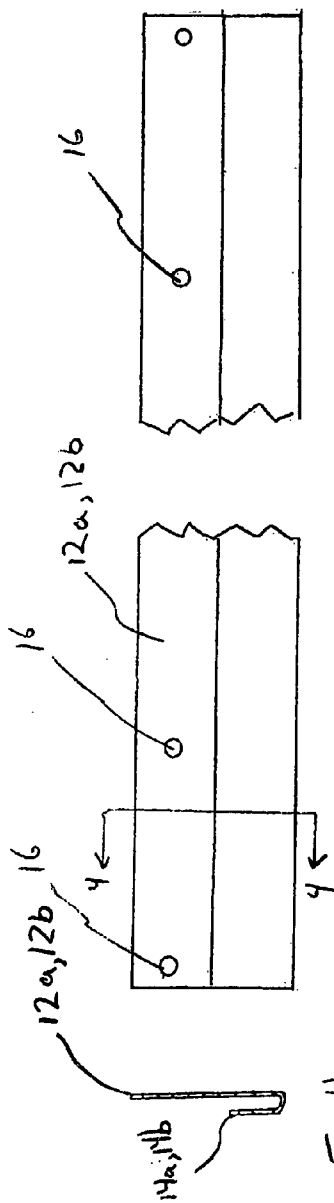

Fig. 3

Fig. 4

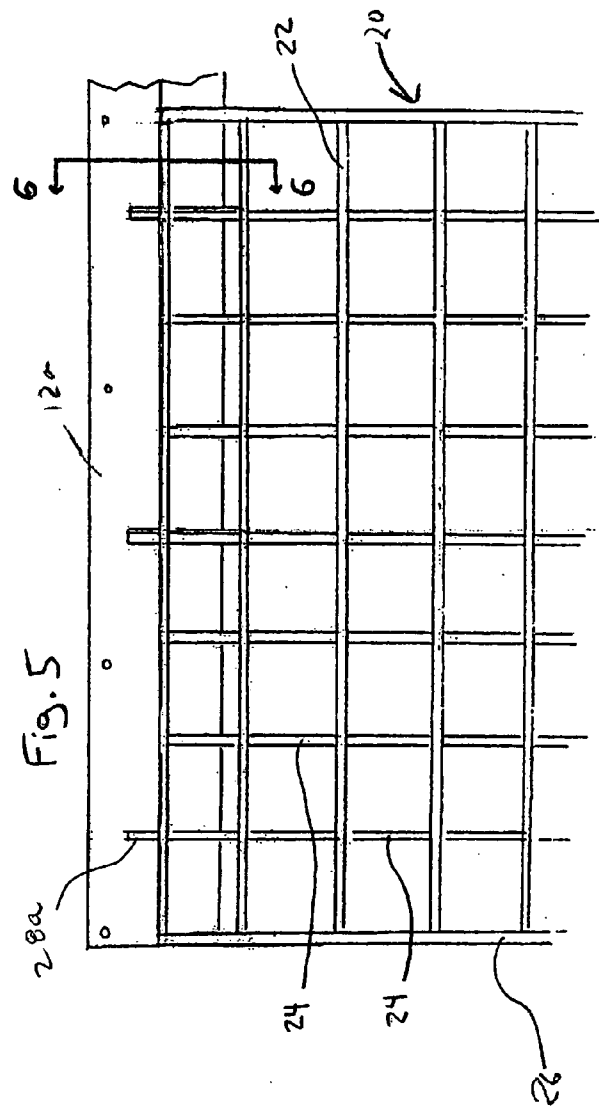

Fig. 5

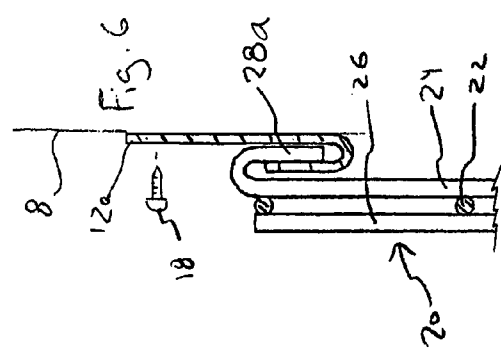

Fig. 6

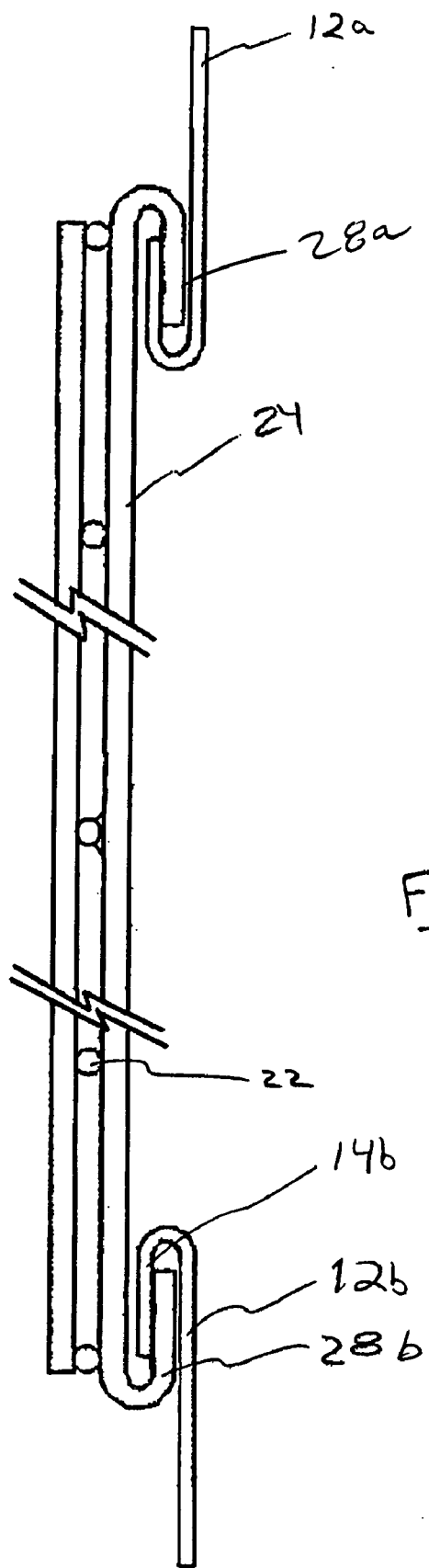

Fig. 7

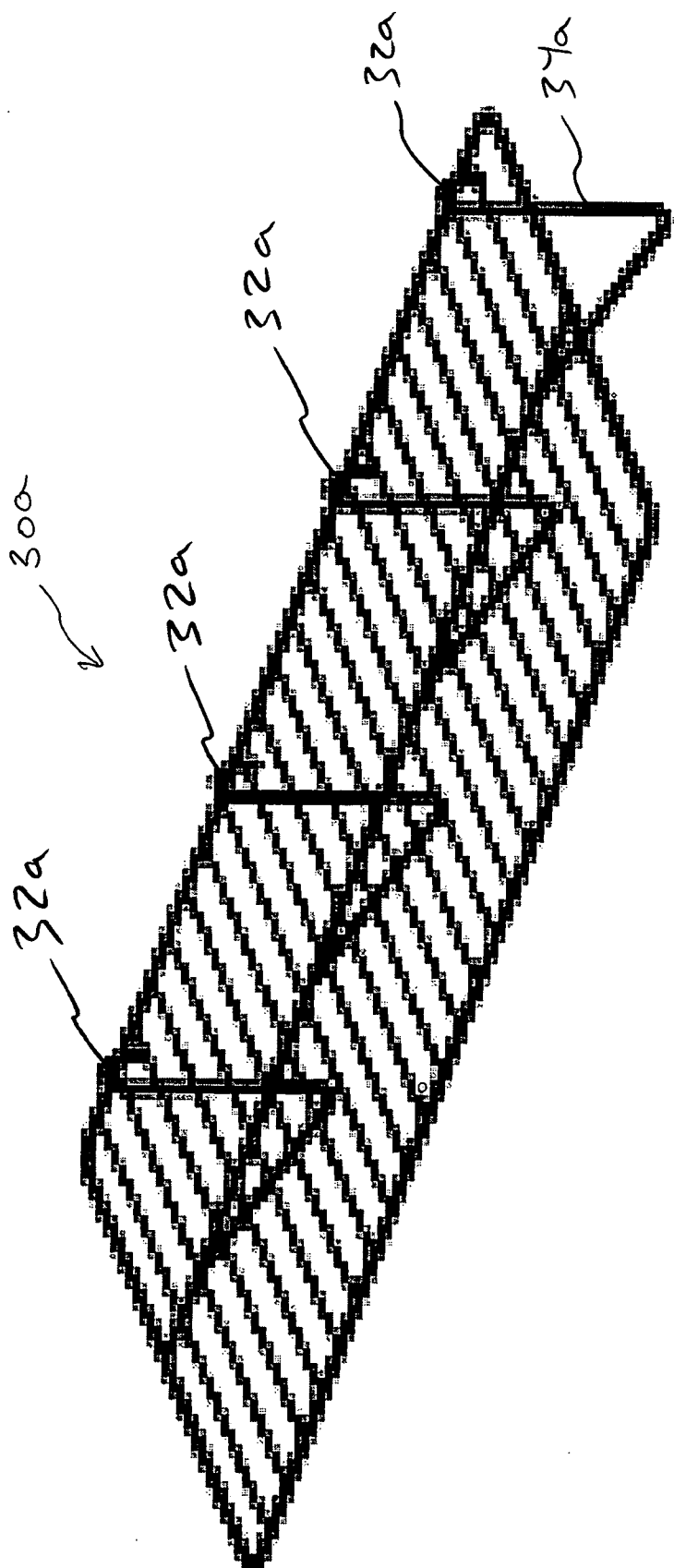

Fig. 8

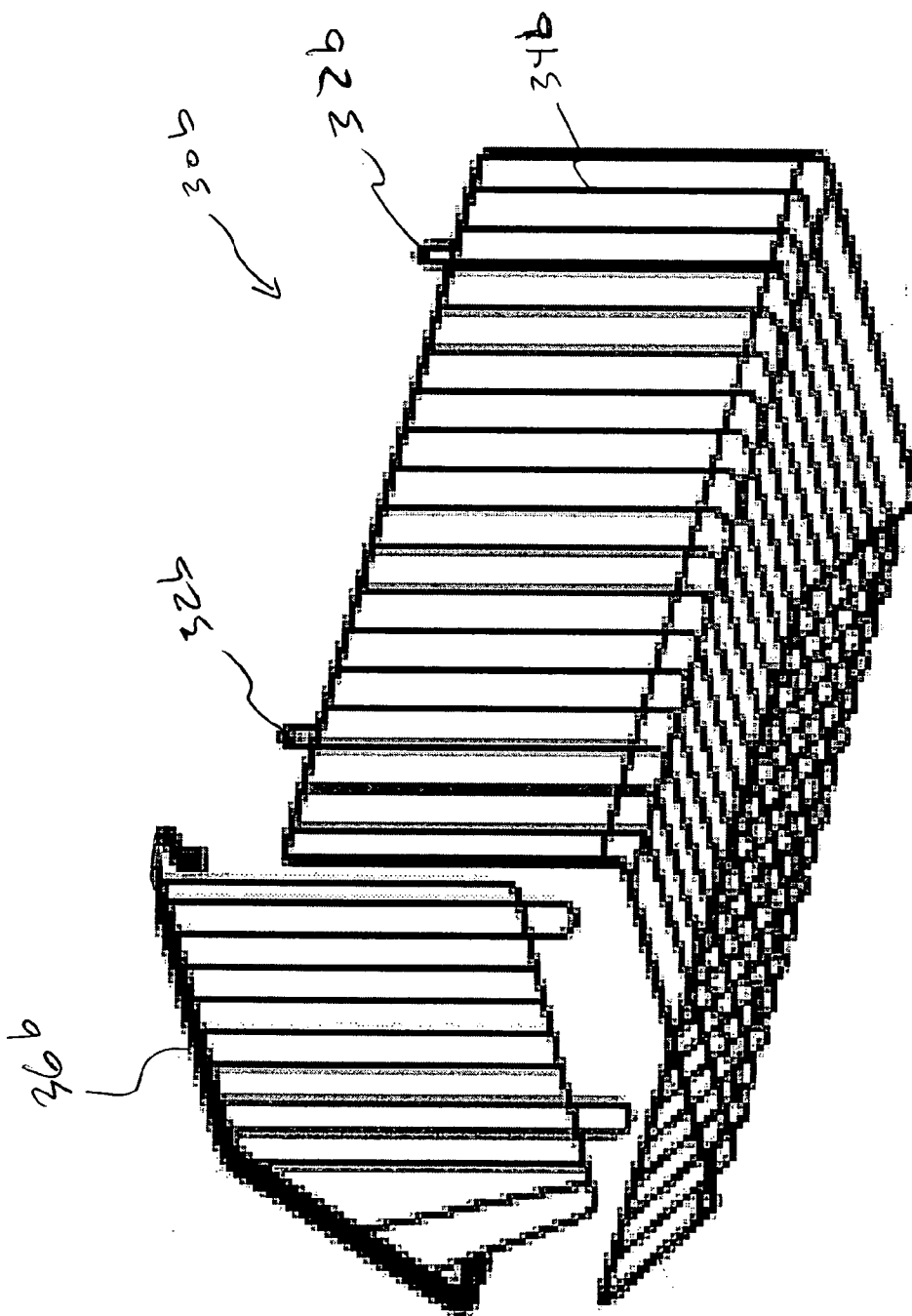

Fig 9

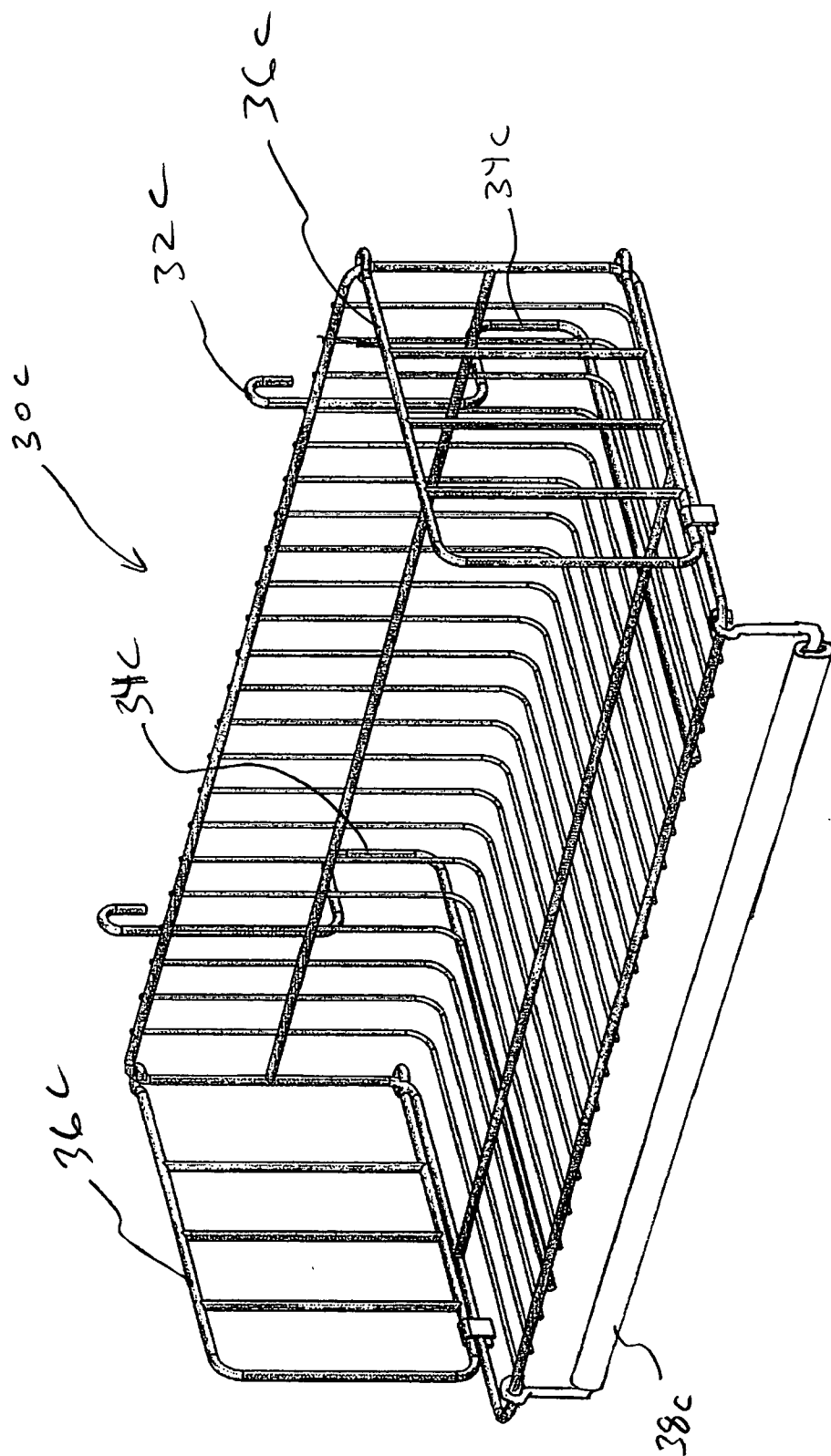

Fig. 10

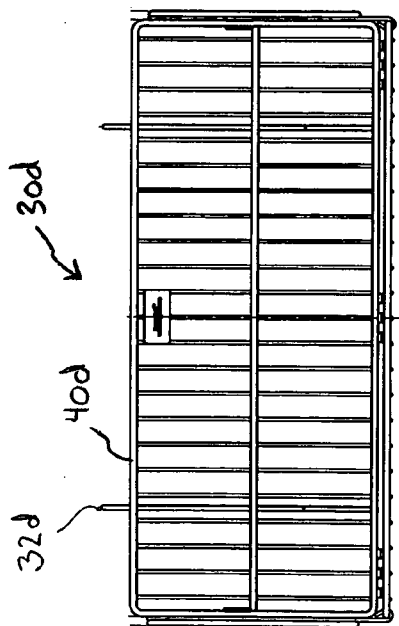

Fig. 11D

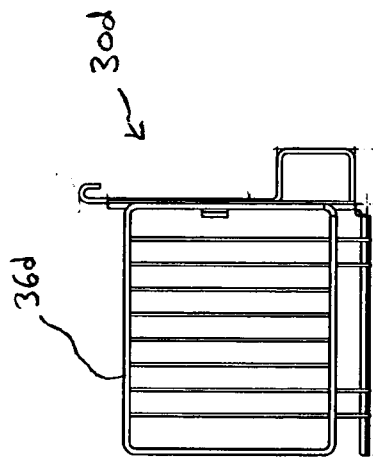

Fig. 11E

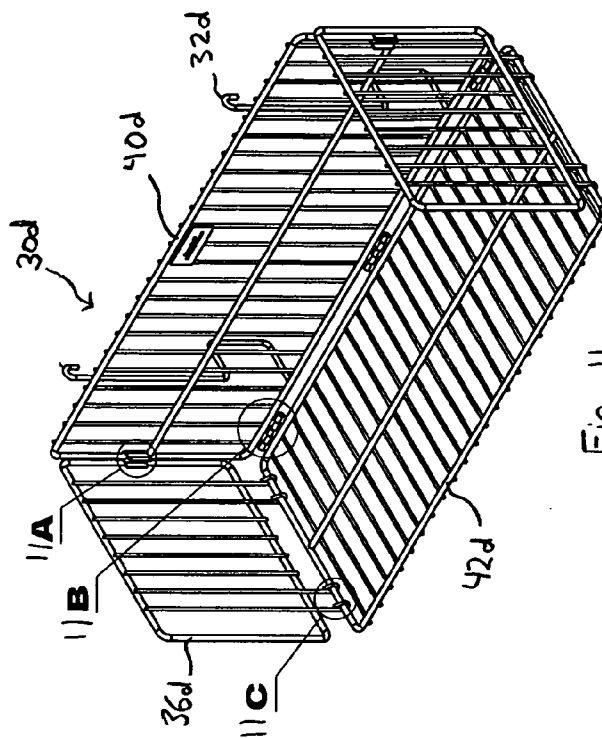

Fig. 11

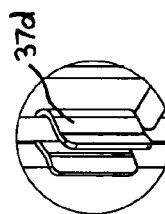

Fig. 11A

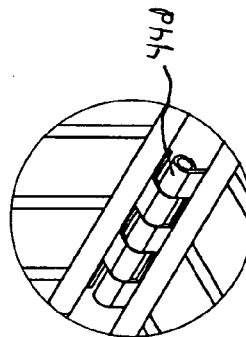

Fig. 11B

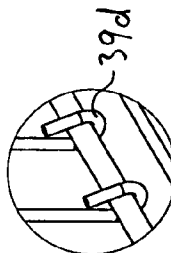
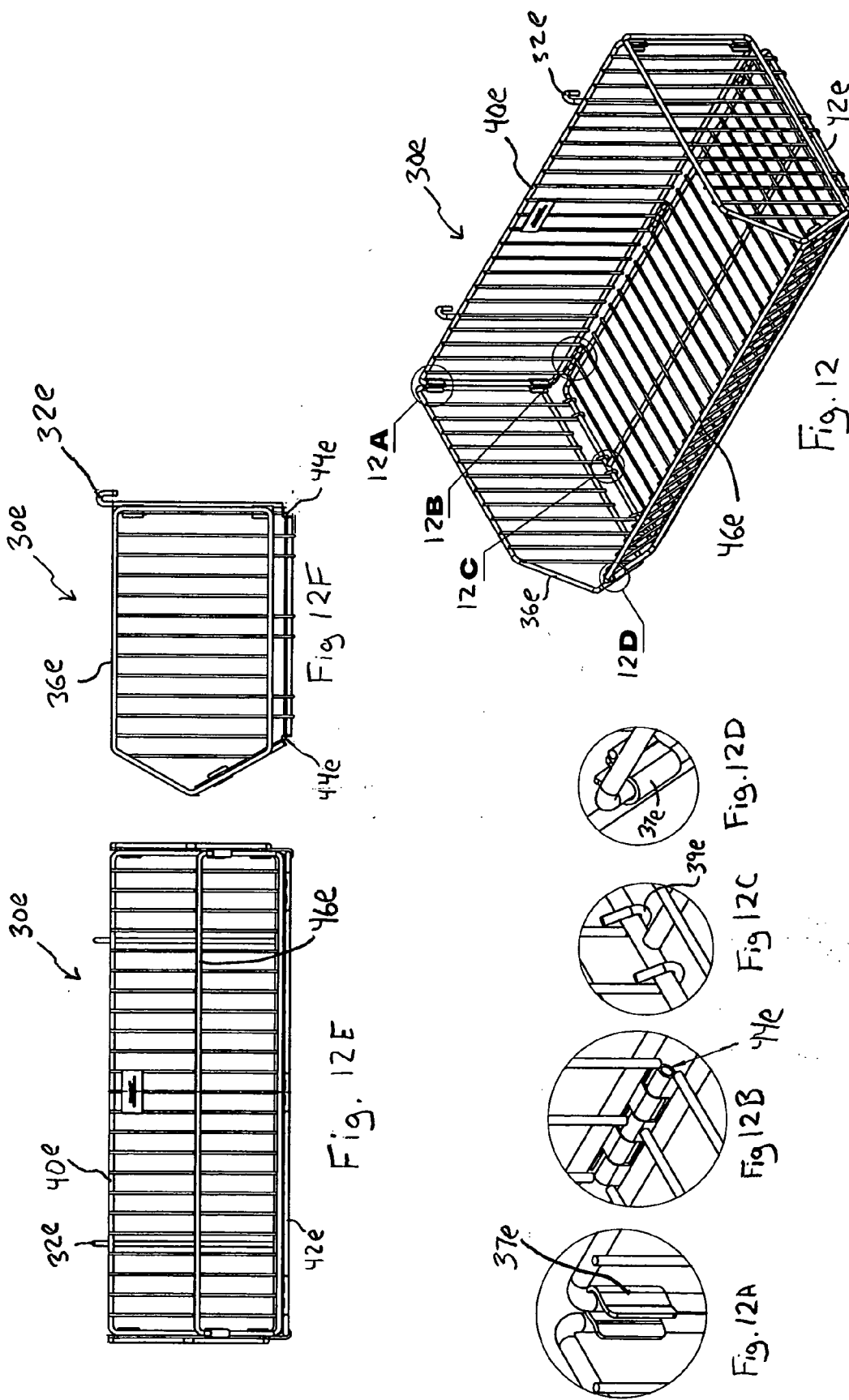

Fig. 11C



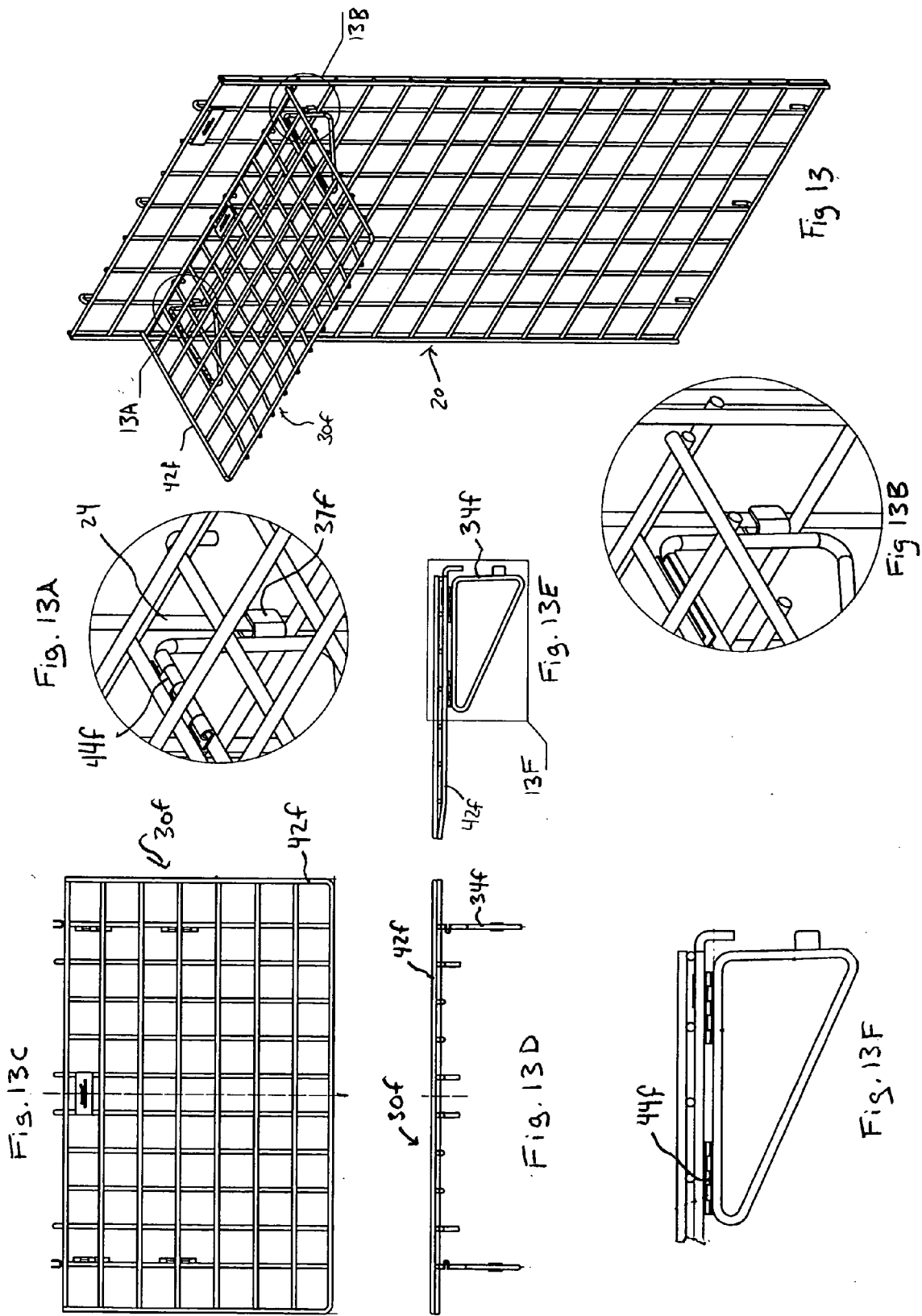

Fig. 15

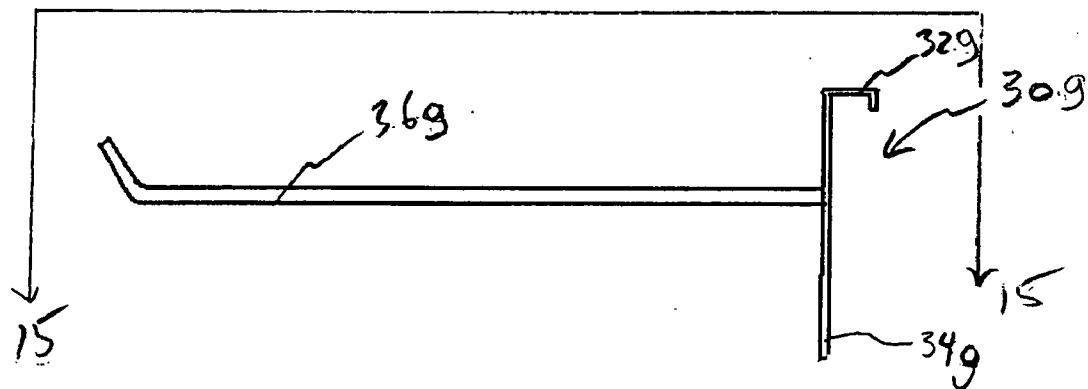
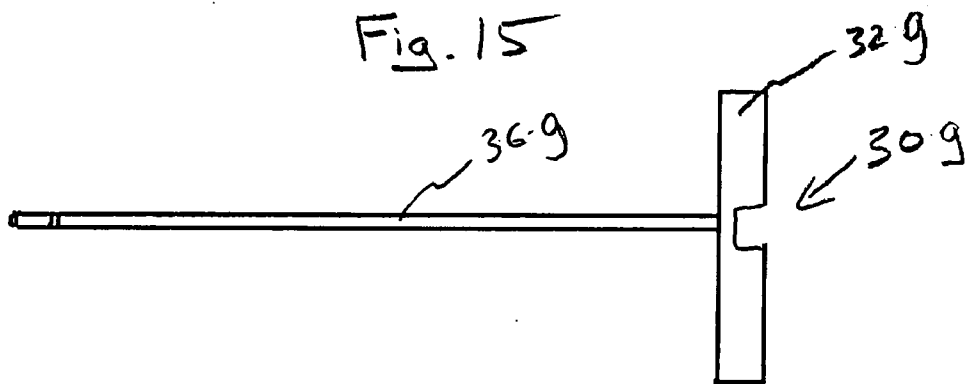

Fig. 14

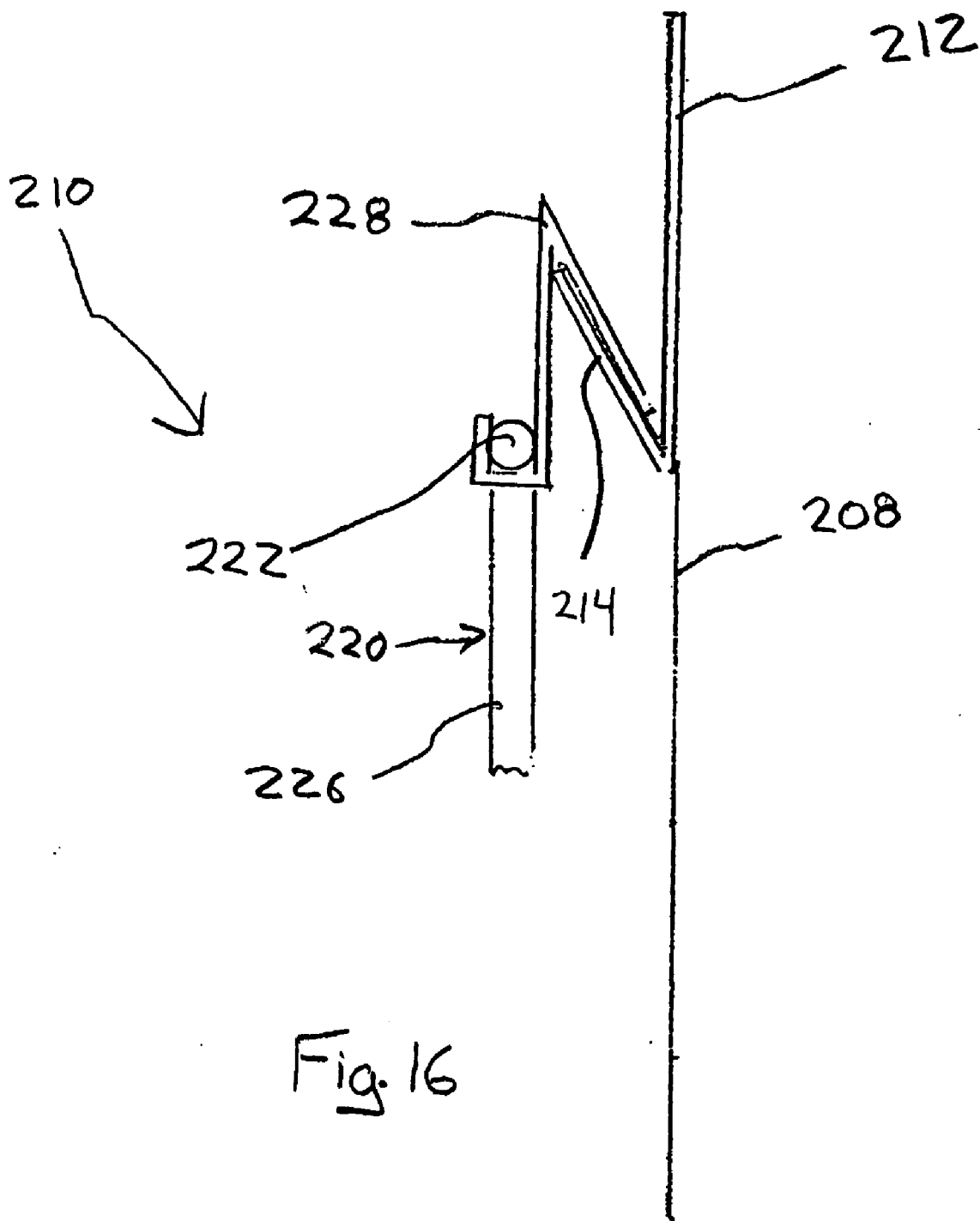

Fig. 16

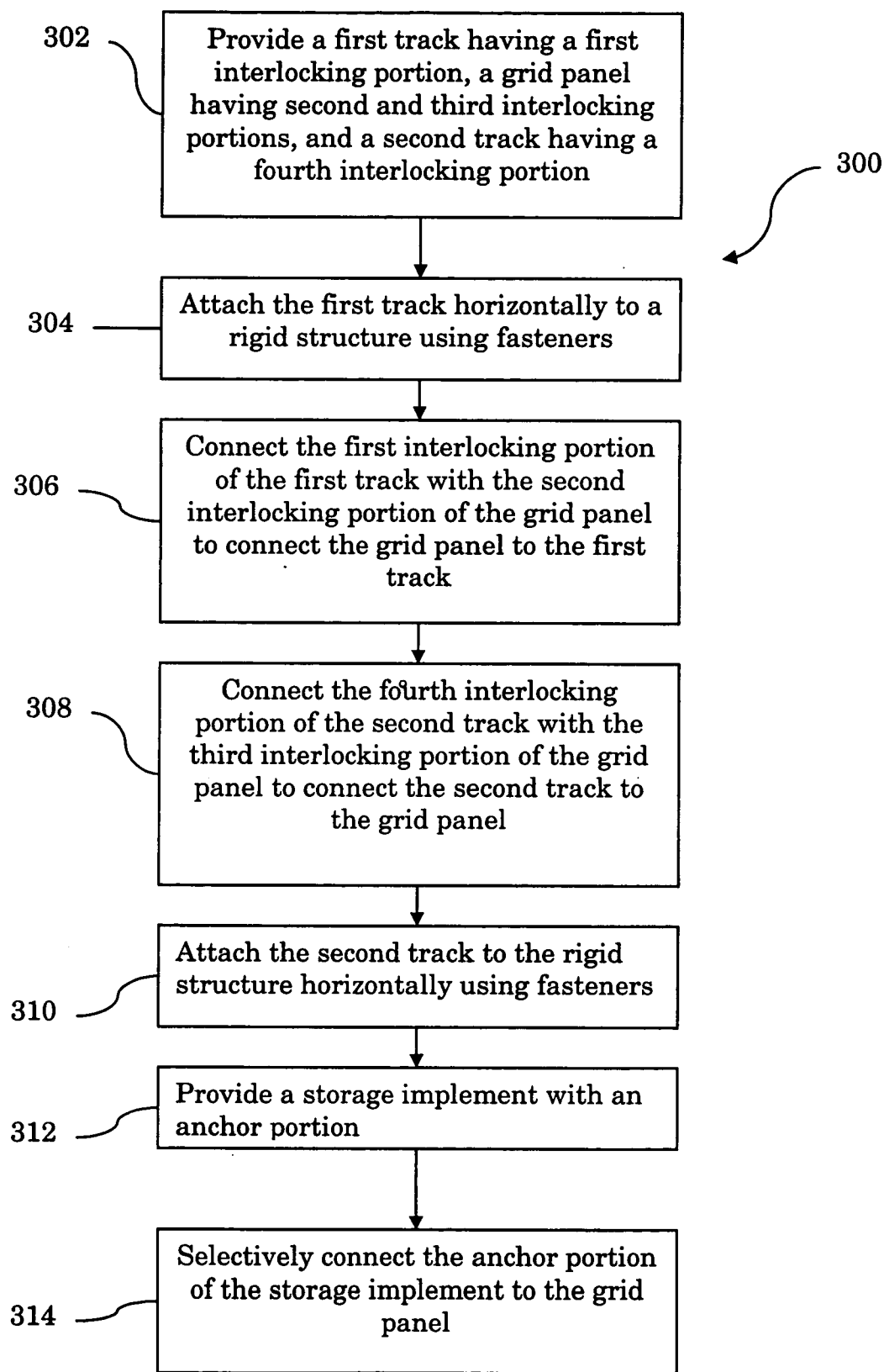

FIG. 17

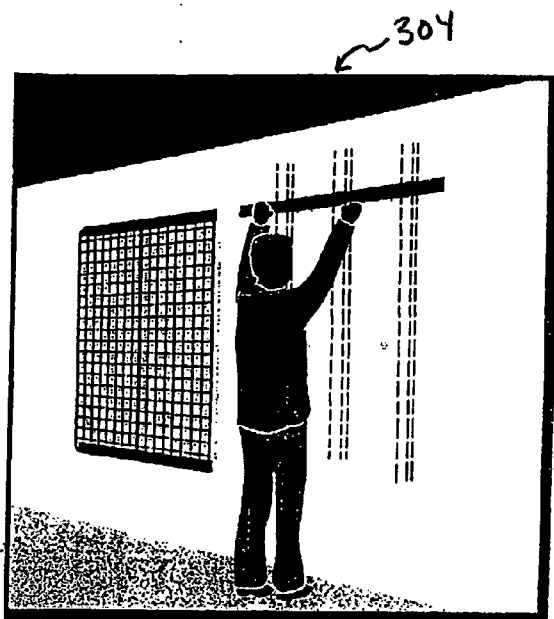

Fig. 18a

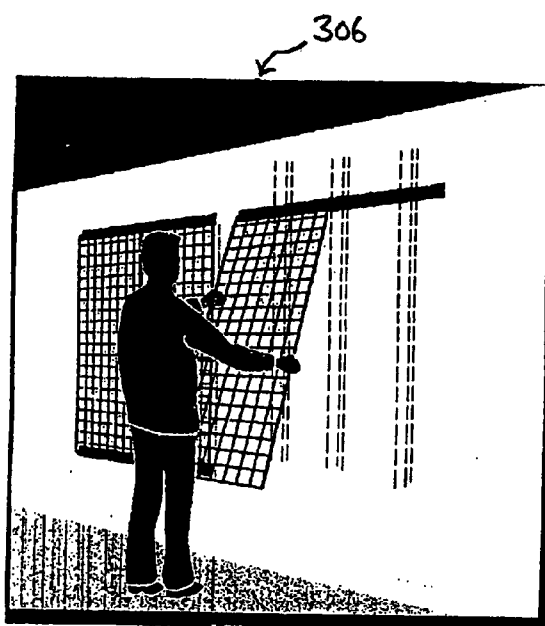

Fig. 18b

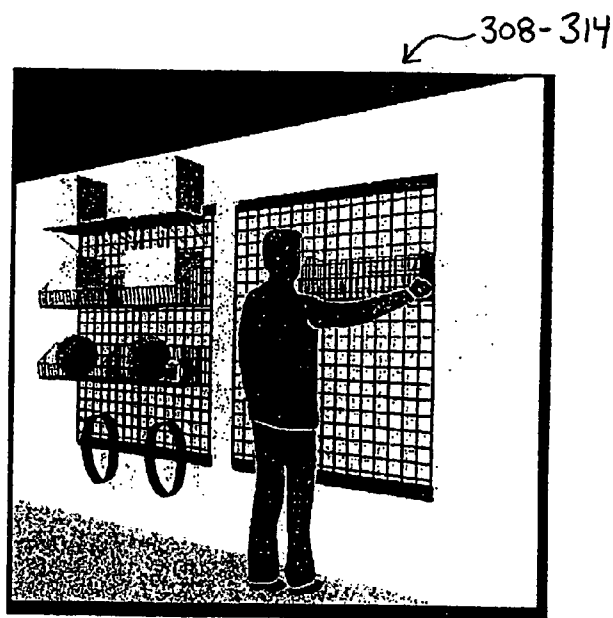

Fig. 18c

GRID PANEL STORAGE SYSTEM

CROSS REFERENCE TO RELATED APPLICATION

[0001] This application claims the benefit of U.S. Provisional Patent Application No. 60/580,514, filed Jun. 17, 2004, which is incorporated by reference herein as if fully set forth.

BACKGROUND

[0002] There is an ever-increasing need for organized storage space. Businesses and private consumers require more room to accommodate their possessions or more efficient systems of storage so that items can be organized in an accessible and easily used manner. Traditionally, utility cabinets and conventional shelving have provided storage for a wide variety of items. However, such systems are often time consuming to install and are not easily adaptable to changing storage requirements.

[0003] It would be desirable to provide a storage system which could accommodate a variety of items of different sizes and shapes. Such a system should allow easy installation and permit a user to make adjustments to the system, without tools, in response to changing storage needs.

SUMMARY

[0004] The present invention provides a storage system. The storage system includes a first horizontal track, adapted for attachment to a structure, having an upwardly directed channel forming a first interlocking portion. A grid panel is provided including horizontal members, crossing members connected to the horizontal members, and at least one first hook member positioned in proximity to a top edge of the grid panel. The at least one first hook member forms a second interlocking portion which is removably connected to the first interlocking portion of the first horizontal track. At least one second hook member is located on the grid panel in proximity to a bottom edge of the grid panel forming a third interlocking portion. A second horizontal track is provided having a downwardly directed channel forming a fourth interlocking portion and is adapted for attachment to the structure. The fourth interlocking portion is removably connected to the third interlocking portion of the grid panel. The present application also provides a method for providing a storage system.

BRIEF DESCRIPTION OF THE DRAWING(S)

[0005] FIG. 1 is a perspective view of a storage system including stored articles according to a preferred embodiment of the present invention.

[0006] FIG. 2 is a perspective view of the storage system of FIG. 1 without storage implements or stored articles.

[0007] FIG. 2a is an exploded perspective view of the storage system of FIG. 2.

[0008] FIG. 3 is a front elevational view of a track representative of the first and second tracks of FIGS. 1 and 2.

[0009] FIG. 4 is a cross-sectional view of the track taken along lines 4-4 of FIG. 3.

[0010] FIG. 5 is a partial front elevational view of the storage system as shown in the perspective view FIG. 2.

[0011] FIG. 6 is a sectional view of the storage system taken along lines 6-6 of FIG. 5.

[0012] FIG. 7 is a side elevational view of the storage system as shown in the perspective view of FIG. 2.

[0013] FIG. 8 is a top perspective view of a first shelf storage implement in accordance with the storage system as shown in FIG. 1.

[0014] FIG. 9 is a top perspective view of a basket storage implement in accordance with the storage system as shown in FIG. 1.

[0015] FIG. 10 is a top perspective view of a second basket storage implement in accordance with the storage system as shown in FIG. 1.

[0016] FIGS. 11-11E show a third basket storage implement in accordance with the storage system as shown in FIG. 1.

[0017] FIGS. 12-12F show a fourth basket storage implement in accordance with the storage system as shown in FIG. 1.

[0018] FIGS. 13-13F show a collapsible shelf storage implement in accordance with the storage system as shown in FIG. 1.

[0019] FIG. 14 is a side elevational view of a hook storage implement in accordance with the storage system as shown in FIG. 1.

[0020] FIG. 15 is a plan view of the hook storage implement taken along lines 15-15 of FIG. 14.

[0021] FIG. 16 is a partial side elevational view of a storage system according to an alternative preferred embodiment of the present invention.

[0022] FIG. 17 is flowchart showing a preferred method for installing a storage system such as the system shown in FIG. 1.

[0023] FIGS. 18a-18c are diagrammatic perspective views illustrating the installation steps for the storage system.

DETAILED DESCRIPTION OF THE PREFERRED EMBODIMENT(S)

[0024] Certain terminology is used in the following description for convenience only and is not considered limiting. Words such as "front", "back", "top" and "bottom" designate directions in the drawings to which reference is made. This terminology includes the words specifically noted above, derivatives thereof and words of similar import. Additionally, the terms "a" and "one" are defined as including one or more of the referenced item unless specifically noted. The phrase "at least one" followed by a list of two or more items (such as A, B, or C) means any individual one of A, B or C as well as any combination thereof.

[0025] The preferred embodiments of the present invention are described below with reference to the drawing figures where like numerals represent like elements throughout.

[0026] FIG. 1 shows a storage system 10 including stored articles 50 according to a preferred embodiment of the present invention. The storage system 10 includes at least a first holder in the form of a track 12a, for attachment to a rigid structure, which removably connects with a grid panel 20. A second holder in the form of a track 12b at the bottom of the grid panel 20 is also provided. Preferably, one or more storage implements 30a, 30b, 30e are provided for selective, removable connection to the grid panel 20. FIG. 2 shows the storage system 10 without the storage implements 30a, 30b, 30e or the stored articles 50.

[0027] Referring to FIGS. 2-6, the grid panel 20 includes horizontal members 22 and crossing members 24 connected to the horizontal members. The horizontal members 22 and crossing members 24 are preferably round steel rod. Alternatively, the members 22,24 may be formed of any suitably shaped rod, bar, or strip, for example, bars having a polygonal cross-section. Also, any suitable material may be used to fabricate the rod, bar or strip including aluminum alloys, plastics or composites.

[0028] Preferably, as shown in FIG. 2, the crossing members 24 are aligned perpendicular to the horizontal members so that they extend generally vertically in the installed position. Alternatively, the horizontal and crossing members 22,24 may be positioned at any suitable angle relative to each other. Also, as shown in FIGS. 5 and 6, each of the horizontal members 22 preferably overlays each of the crossing members 24 on one side of the crossing members 24 opposite the first track 12a. Alternatively, the horizontal members 22 may underlay the crossing members 24 on an opposite side of the crossing members 24 facing the first track 12a. It is also possible to locate some of the horizontal members 22 over the crossing members 24 while other ones of the horizontal members 22 may underlay the crossing members 24, for example, in an alternating fashion. Further, the members 22,24 may be fully or partially woven, for example, with at least one of the horizontal members 22 overlying some of the crossing members and passing under other ones of the crossing members 24. Preferably, end members 26 are provided on the edges of the grid panel 20 overlying the horizontal members 22 on an opposite side of the crossing members 24. This configuration provides the grid panel with additional strength.

[0029] The first track 12a includes spaced apertures 16 for receiving fasteners 18. The fasteners 18 are effective for securing the first track 12a to a rigid structure such as wood or metal studs beneath a wall surface. The apertures may be uniformly spaced, for example, every inch, or are preferably spaced to coincide with typical building stud spacing, for example, 16 or 24 inches between aperture centers. Most preferably, the apertures are spaced a distance in inches approximately equal to a number by which numbers 24 and 16 (corresponding to typical building stud spacing distance) are evenly divisible, i.e. 1, 2, 4, and 8 inches. Alternatively, the apertures 16 may be omitted, and fasteners can be driven through the first track 12a, or other features can be provided for allowing connection to a rigid structure.

[0030] The first track 12a also includes a J-shaped upwardly directed channel 14a forming a first interlocking portion. The grid panel 20 includes J-shaped extensions 28a, which extend from the top of the grid panel 20 from some or all of the crossing members 24, functioning as hook

members and forming a second interlocking portion. The first and second interlocking portions are joined; the J-shaped channel 14a of the track 12a and the J-shaped extensions 28a are preferably initially held together by gravity.

[0031] A second track 12b, preferably identical to the first track 12a, is installed at a location corresponding to a bottom edge of the grid panel 20. A J-shaped downwardly directed channel 14b of the second track 12b engages with the J-shaped extensions 28b at the bottom edge of the grid panel 20 which function as hook members. The second track 12b prevents the grid panel from rotating about or being lifted upwardly and disconnecting from the first track 12a.

[0032] FIGS. 1 and 8-14 show various storage implements 30a-30e, which are removably connectable to the grid panel 20. The storage implements 30a-30e may be fabricated from any suitable material including metal or plastic.

[0033] FIG. 8 shows a shelf storage implement 30a including curved members which form anchor portions 32a for engaging one of the horizontal members 22 of the grid panel 20. A downwardly extending brace portion 34a is also provided having a length sufficient to contact at least the next lower adjacent horizontal member 22 to transfer the moment created when the storage implement is loaded to the horizontal members 22.

[0034] FIG. 9 shows a basket storage implement 30b including anchor portions 32b and downwardly extending portions 34b for attachment to the grid panel 20. Preferably, removable panels such as removable panel 36b are provided which can be attached at various locations along the length of the storage implement 30b. The panels 36b restrict side-to-side movement of items placed in the basket storage implement 30b.

[0035] FIG. 10 shows a second basket storage implement 30c including anchor portions 32c for attachment to the horizontal members 22 of the grid panel 20. Outwardly projecting portions 34c which rest on the horizontal members 22 in an installed position tilt the second basket implement 30c relative to horizontal. Preferably, removable panels 36c are provided which can be attached at various locations along the length of the storage implement 30c. Optionally, a utility bar 38c is connected along an edge of the second basket implement 30c, and can be used for hanging items, for example, in a laundry application.

[0036] FIGS. 11-11E show a third basket storage implement 30d having a back panel 40d and a bottom panel 42d which are pivotably joined by a pivotjoint including hinges 44d allowing the back and bottom panels 40d, 42d to reside in the same plane in an uninstalled position. This allows easier and less costly shipping. Side panels 36d are provided to lock the back and bottom panels 40d, 42d into position relative to each other. The side panels 36d are preferably pivotable and include permanent slideable pivot connections such as closed hooks 39d which allow each of the side panels to pivot and slide relative to the bottom panel 42d. The side panels 36d can also reside in a plane with the back and bottom panels 40d, 42d in an uninstalled position. Preferably, one side panel 36d is installed at each end of the third basket storage implement 30d to lock the back panel 40d at approximately 90 degrees relative to the bottom panel 42d using connector hooks 37d permanently attached to the

side panel 36*d*. Alternatively, the side panel 36*d* may be installed at intermediate positions along the length of the storage implement 30*d*. Also, the side panel 36*d* may alternatively be configured to be removable from both the back and bottom panels 40*d*, 42*d*. Anchor portions 32*d* are provided for attaching the third basket storage implement 30*d* to the grid panel 20.

[0037] FIGS. 12-12F show a fourth basket storage implement 30*e* having a back panel 40*e*, a bottom panel 42*e* and a front panel 46*e* which are pivotably joined by pivot joints including hinges 44*e* allowing the back, bottom, and front panels 40*e*, 42*e*, 46*e* to reside in the same plane in an uninstalled position. This allows easier and less costly shipping. Side panels 36*e* are provided to lock the back, bottom and front panels 40*e*, 42*e*, 46*e* into position relative to each other. The side panels 36*e* are preferably pivotable and include permanent slideable pivot connections such as closed hooks 39*e* which allow each of the side panels 36*e* to pivot and slide relative to a the bottom panel 42*e*. The side panels 36*e* also reside in a plane with the back, bottom and front panels 40*e*, 42*e*, 46*e* in an uninstalled position. Preferably, one side panel 36*e* is installed at each end of the fourth basket storage implement 30*e* to lock the back, bottom and front panels 40*e*, 42*e*, 46*e* into position using connector hooks 37*e* permanently attached to the side panels 36*e*. Alternatively, the side panel 36*e* may be installed at intermediate positions along the length of the storage implement 30*e*. Also, the side panel 36*e* may alternatively be configured to be removable from the back, bottom and front panels 40*e*, 42*e*, 46*e*. Anchor portions 32*e* are provided for attaching the fourth basket storage implement 30*e* to the grid panel 20.

[0038] Referring to FIGS. 13-13F, a collapsible shelf storage implement 30*f* is shown. FIGS. 13, 13A and 13B show the collapsible shelf storage implement 30*f* in an installed position on the grid panel 20. The collapsible shelf storage implement 30*f* is similar to the shelf storage implement 30*a*. However, the collapsible shelf storage implement 30*f* includes collapsible brace portions 34*f* which are pivotably connected to a shelf portion 42*f* via hinges 44*f*. Connector hooks 37*f* attached to each of the brace portions 34*f* removably connect the brace portions 34*f* to the crossing members 24 of the grid panel 20.

[0039] The FIGS. 14 and 15 show a hook storage implement 30*f* including an anchor portion 32*f*, a downwardly extending portion 34*f*, and a hook portion 36*f* for hanging an article.

[0040] FIG. 16 shows a partial elevational view of a storage system 210 according to an alternative preferred embodiment of the present invention. The storage system 210 includes a grid panel 220 having horizontal members 222 and crossing members 226. Preferably, one of the horizontal members 222 connects with at least one cleat 228. The cleat 228 removably attaches with a holder 212 which includes a J-shaped channel 214 for receiving a portion of the cleat 228 and retaining the grid panel 220.

[0041] While the illustrated embodiments show the grid panel 20,220 as having a greater height than width, the width and height can be varied to accommodate any particular space.

[0042] Referring to FIG. 17, a flow chart depicting a preferred method for installing a system such as the system

10 is shown. FIGS. 18*a-c* show diagrammatic views of some of the steps of the preferred method.

[0043] The method includes providing a first track having a first interlocking portion, providing a grid panel having a second interlocking portion, a third interlocking portion and horizontal members, and providing a second track having a fourth interlocking portion (step 302). Preferably, the step of providing the first track includes providing the first track with one or more J-shaped upwardly directed channels that form the first interlocking portion. The step of providing the grid panel preferably includes providing the grid panel with one or more J-shaped extensions that form the second interlocking portion at a top thereof and one or more J-shaped extensions that form the third interlocking portion at a bottom thereof. Further, the step of providing the second track includes providing the second track with one or more J-shaped downwardly directed channels that form the fourth interlocking portion.

[0044] The first track is attached horizontally to a rigid structure using fasteners (step 304). Preferably, one screw is first installed positioned approximately midway between ends of the first track to loosely connect the first track to a rigid structure. Subsequently, the track is horizontally leveled. After leveling the first track, one or more additional screws is used complete the mounting of the first track. In the case of mounting the system to a finished wall, the rigid structure may include the metal or wood studs beneath the wall surface. Preferably, threaded fasteners such as wood screws are used. Alternatively, any suitable fastening systems including machine screws, bolts, straps, clamps or adhesives may be used. After attaching the first track to the rigid structure, the grid panel is connected to the first track by connecting the first interlocking portion of the first track with the second interlocking portion of the grid panel (step 306).

[0045] The second track is connected to the grid panel by connecting the fourth interlocking portion of the second track with the third interlocking portion of the grid panel (step 308), and the second track is attached horizontally to the rigid structure using fasteners (step 310).

[0046] Using the system according to the invention, installation of the grid panel 20 can be completed in a matter of minutes with a few simple tools that are typically available in a common household, such as a screw driver and a level. The known prior art systems are all more complicated to install and therefore are less attractive to homeowners, who form a large market segment.

[0047] The method further includes providing one or more storage implements, each having at least one anchor portion (step 312). The storage implement is connected to the grid panel preferably by selectively connecting the anchor portion to at least one of the horizontal members of the grid panel (step 314). This is also quickly and easily accomplished according to the invention, which also allows for easy repositioning as necessary.

[0048] While the preferred embodiments of the invention have been described in detail above, the invention is not limited to the specific embodiments described, which should be considered as merely exemplary. Further modifications and extensions of the present invention may be developed, and all such modifications are deemed to be within the scope of the present invention as defined by the appended claims.

What is claimed is:

1. A storage system comprising:
 - a first horizontal track adapted for attachment to a structure having a substantially continuous upwardly directed channel forming a first interlocking portion;
 - a grid panel, including horizontal members, crossing members connected to the horizontal members, and at least one first hook member positioned in proximity to a top edge of the grid panel, the at least one first hook member forming a second interlocking portion, wherein the second interlocking portion is removably connected to the first interlocking portion of the first horizontal track, and at least one second hook member positioned in proximity to a bottom edge of the grid panel, the at least one second hook member forming a third interlocking portion; and
 - a second horizontal track adapted for attachment to the structure having a substantially continuous downwardly directed channel forming a fourth interlocking portion, wherein the fourth interlocking portion is removably connected to the third interlocking portion of the grid panel.
2. The storage system of claim 1, wherein at least one of the upwardly and downwardly directed channels are J-shaped.
3. The storage system of claim 2, wherein the at least one first hook member and the at least one second hook member are J-shaped and are formed in one piece with at least one of the crossing members.
4. The storage system of claim 1, wherein at least one of the first and second tracks comprises a formed metal channel having a flange with spaced apart apertures for mounting the at least one of the first and second tracks to a rigid structure using fasteners passing through the apertures.
5. The storage system of claim 1, wherein the first horizontal track includes a plurality of horizontally spaced apertures for receiving fasteners therethrough.
6. The storage system of claim 5, wherein the apertures are approximately spaced apart by a distance of at least one of 1, 2, 4, and 8 inches.
7. The storage system of claim 1, wherein the at least one first hook member includes a plurality of J-shaped extensions integrally formed with at least two of the crossing members.
8. The storage system of claim 7, wherein the at least one second hook member includes a plurality of J-shaped extensions integrally formed with at least two of the crossing members.
9. The storage system of claim 1, wherein the horizontal members comprise rods.
10. The storage system of claim 9, wherein the crossing members comprise rods positioned substantially perpendicular to the horizontal members and joined to the horizontal members at intersections of the members.
11. The storage system of claim 1, further comprising at least one storage implement which comprises at least one anchor portion which selectively, removably, connects to the at least one of the horizontal members of the grid panel.
12. The storage system of claim 11, wherein the at least one storage implement further comprises a shelf.
13. The storage system of claim 12, wherein the at least one storage implement further comprises an elongated member positioned adjacent and substantially parallel to the shelf opposite the first horizontal track in an installed position.
14. The storage system of claim 1, further comprising at least one storage implement which comprises:
 - a first member;
 - a second member pivotably connected to the first member;
 - a third member removably connected to at least the first and second members; and
 - an anchor member connected to at least one of the first, second and third members which selectively, removably, connects to the grid panel.
15. The storage system of claim 1, further comprising at least one storage implement which comprises:
 - a first panel;
 - a second panel pivotably connected to the first panel;
 - a third panel removably connected to at least the first and second panels;
 - a fourth panel removably connected to at least the first and second panels; and
 - an anchor member connected to at least one of the first, second, third and fourth panels which selectively, removably, connects to the grid panel;
 wherein the first, second, third, and fourth panels substantially enclose a bottom and sides of a storage area.
16. A method for providing a storage system, the method comprising:
 - providing a first track having a first interlocking portion;
 - providing a grid panel having a second interlocking portion in proximity to a top edge of the grid panel, a third interlocking portion in proximity to a bottom edge of the grid panel and a plurality of horizontal members;
 - providing a second track having at least a fourth interlocking portion;
 - providing at least one storage implement having an anchor portion;
 - connecting the first track horizontally to at least one rigid structure using at least two fasteners;
 - connecting the grid panel to the first track by connecting the second interlocking portion with the first interlocking portion;
 - connecting the fourth interlocking portion of the second track to the third interlocking portion of the grid panel;
 - connecting the second track horizontally to the at least one rigid structure using at least two fasteners; and
 - selectively connecting the anchor portion of the at least one storage implement to the grid panel.
17. The method of claim 16, further comprising providing the first track as a J-shaped upwardly directed channel which forms the first interlocking portion and providing the grid panel with at least one J-shaped hook member which forms the second interlocking portion.
18. The method of claim 17, further comprising providing the second track as a J-shaped downwardly directed channel which forms the first interlocking portion and providing the

grid panel with at least one J-shaped hook member which forms the second interlocking portion.

19. The method of claim 16, wherein the connecting the first track includes attaching at least one of the first and the second tracks to a plurality of vertically oriented wall studs using a plurality of fasteners.

20. The method of claim 16, further comprising providing the first track with a plurality apertures spaced by a distance

of at least one of 1, 2, 4, and 8 inches, wherein the attaching the first track includes attaching at least one of the first and the second tracks to a plurality of vertically oriented wall studs using a plurality of screws inserted through the plurality of spaced apertures.

* * * * *