

Dec. 27, 1932.

R. O. EATON

1,891,920

ELECTRICAL CONNECTING DEVICE

Filed Nov. 28, 1928

Fig. 1.

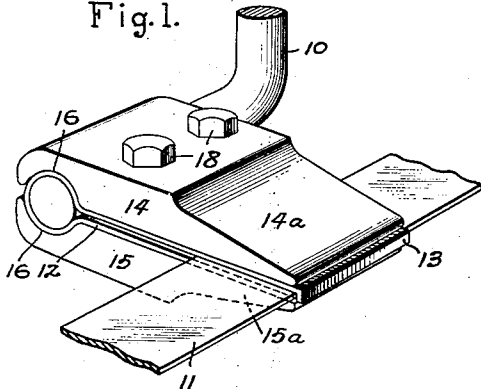

Fig. 2.

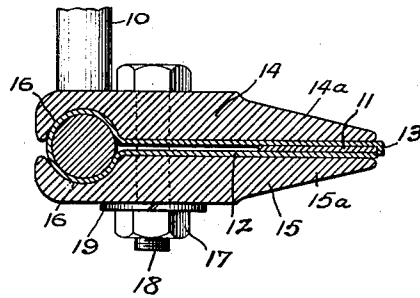

Fig. 3.

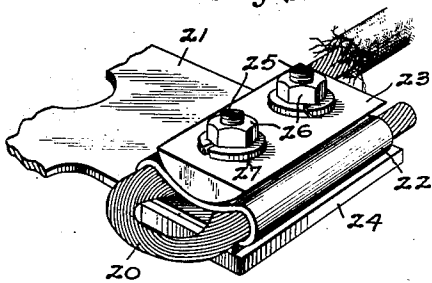
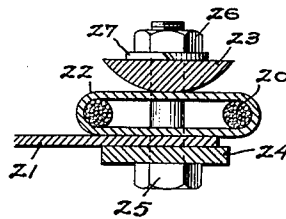

Fig. 4.



Inventor:  
Reginald O. Eaton,  
by *Charles E. Muller*  
His Attorney.

# UNITED STATES PATENT OFFICE

REGINALD O. EATON, OF WESLEYVILLE, PENNSYLVANIA, ASSIGNOR TO GENERAL ELECTRIC COMPANY, A CORPORATION OF NEW YORK

## ELECTRICAL CONNECTING DEVICE

Application filed November 28, 1928. Serial No. 322,447.

My invention relates to electrical connecting devices, more particularly to devices for connecting together electrical conductors, and has for its object the provision of a simple and efficient device of this character.

My invention has especial application to devices for interconnecting conductors of different cross sections, as for example where a conductor or terminal having an oval or circular cross section is to be connected to a ribbon conductor such as is used in edgewise wound resistors. It is essential that connecting devices for this type of work not only be mechanically strong but also be efficient electrically so that relatively large currents may be conducted without appreciable resistance losses between the connected parts.

To accomplish these results in accordance with my invention I have provided a yielding metal strip formed in loop shape to incase portions of the conductors to be connected together and thereby provide a good electrical connection therebetween, together with strong clamping means for maintaining the strip in firm engagement with both conductors.

For a better understanding of my invention reference may be had to the accompanying drawing in which Fig. 1 is a perspective view and Fig. 2 a vertical cross sectional elevation of a connecting device embodying one form of my invention, while Fig. 3 is a perspective view and Fig. 4 a vertical cross sectional elevation of a clamp connector embodying another form of my invention.

Referring to the drawing, in carrying out my invention in one form, I have provided a device for connecting a terminal conductor 10 to a ribbon conductor 11. It is to be understood that the conductor 11 may be any conductor such, for instance, as an edgewise wound resistor and that the terminal 10 may be connected to any device or apparatus to which it is desired to connect the ribbon conductor 11. To obtain good electrical conduction between the conductors, I have provided a connecting sheet or strip 12 of sheet metal, this strip being preferably formed of a relatively soft yielding metal such as copper. One end of the strip is formed with a portion

13 bent over at right angles and at the center, the strip is bent in the form of a loop so as to fit snugly around the conductor 10 with the ends of the strip engaging the ribbon conductor 11 on both sides thereof. A pair of rugged non-yielding clamping plates 14 and 15 having jaws 14-a and 15-a respectively, are provided, one surface of each of these plates being provided with a groove 16 having a semi-circular cross section. Each of the grooves 16 is of a size slightly larger than the terminal 10 so that when the clamping plates 14 and 15 are drawn together around the loop-shaped strip 12, as is shown in the drawing, the grooved portions of the clamping plates will force the strip 12 into good conduction relation with the conductor 10. The loop and the clamping plates 14 and 15 are provided with suitable apertures, not shown, in registering relation, adapted to receive a pair of bolts 17 (these bolts being provided with the usual nuts 18 and lock washers 19. The bolts 17 serve to draw the clamping plates 14 and 15 together around the metal loop or strip 12, and thereby maintain the loop shaped strip in close engagement with the conductors 10 and 11. The bent-over portion 13 prevents the slipping of the ribbon conductor 11 from the jaws 14-a, 15-a of the clamp while the clamp is being attached.

The loop or strip 12, being of relatively soft yielding metal readily conforms with the surfaces of the conductors 10 and 11 and slight irregularities in the shapes of the conductors will be compensated for by a resulting deformation of the strip. It will thus be seen that I have provided a connecting device which is mechanically strong and which will insure an efficient electrical contact between the conductors 10 and 11.

I have disclosed in Figs. 3 and 4 a modification of my connecting clamp, this modification being especially adaptable to the connecting of a stranded cable 20 to a flat member such as the sheet metal plate or terminal 21. Instead of using an open-ended, connecting strip such as is disclosed in the modification shown in Figs. 1 and 2, I have provided an endless loop or band 22, also of a soft yielding metal such as copper. A pair of

clamping members 23 and 24 are provided, the member 23 having a cross section of a segment of a circle, while the member 24 is in the form of a plate or ribbon, flat on both sides. The end of the conductor 20 is bent upon itself as is shown in Fig. 3 and the loop 22 is then slipped over the bent portion so formed. The terminal 21, loop 22 and clamping members 23 and 24 are provided with apertures in registering relation adapted to receive a pair of bolts 25 provided with suitable nuts 26 and washers 27. After the parts are assembled as is shown in Fig. 4 the nuts 26 are tightened and the upper portion of the loop 22 is forced downwardly by the clamping plate 23, thus compressing the stranded conductor 20. The loop 22 and consequently the conductor 20 will thus be held securely against the terminal member 21, and due to the compressing of the yielding copper loop 22 and the conductor 20, an efficient electrical contact between the conductor 20 and the terminal member 21 will be maintained. The loop 22 prevents the loosening or fraying of the strands of the conductor 20, all of the strands of the conductor being securely held between the clamping plate 23 and the terminal member 21.

While I have described my invention as embodied in two preferred forms, it should be understood that I do not limit my invention thereto, since various modifications thereof will suggest themselves to those skilled in the art without departing from the spirit of my invention, the scope of which is set forth in the annexed claims.

What I claim as new and desire to secure by Letters Patent of the United States, is:

1. A terminal clamp for connecting a conductor of round cross section and a conductor of the ribbon type, comprising a pair of clamping plates provided with registering grooves, a soft metal strip bent into a loop to incase portions of said conductors, and means for drawing said plates toward each other to substantially surround said loop so as to compress said loop into yielding engagement with said conductors, said round conductor being encased by said loop within the grooves in said plate.

2. A connecting device for clamping together a conductor of round cross section and a conductor of the ribbon type, comprising a loop of relatively soft yielding metal formed to substantially incase portions of said conductors, a pair of clamping plates substantially surrounding said loop, said loop and said plates being provided with apertures in registering relation, and bolts mounted in said apertures for drawing said plates together to surround said loop and compressing said loop into yielding engagement with said conductors.

3. A connecting device for clamping together a conductor of round cross section

and of flat cross section, comprising a metal loop of relatively soft metal formed to substantially surround portions of said conductors, a pair of clamping plates arranged at opposite sides of said loop, each of said plates being provided at one end with a groove in registering relation with said conductor of round cross section, and means for drawing said plates together so as to compress said loop around said conductors, said round conductor being incased by said loop within the grooves in said plates.

4. A connecting device for clamping together a conductor having a round cross section and a conductor of the ribbon type, comprising a loop of relatively soft metal formed to substantially surround portions of said conductors, a pair of clamping plates arranged at opposite sides of said loop, each of said plates being provided at one end with a semi-circular groove, and means for drawing said plates together so as to compress said loop around said conductors, said round conductor being incased by said loop within the grooves in said plates.

5. A device for connecting a round conductor and a flat conductor, comprising a pair of opposing clamps having cooperating grooves in the adjacent sides thereof, a soft metal member looped around the conductors between said clamps, said clamps substantially surrounding said loop, and means for drawing said clamps toward each other to compress said looped member into engagement with said conductors with the member substantially surrounding one of said conductors within said grooves.

6. A device for interconnecting a round conductor and a flat conductor, comprising a relatively soft metal member in contact with each of said conductors, a pair of clamping members having cooperating parts formed to compress one portion of the soft metal member into curved contacting engagement with the round conductor and another portion of the member into flat contacting engagement with the flat conductor, said clamp substantially surrounding said loop.

7. A device for interconnecting a conductor having a round cross section and a conductor of the ribbon type, comprising a loop of relatively soft metal formed to substantially surround portions of said conductors, a pair of clamping plates for forcing said loop into engagement with said conductors, each of said plates being provided with a groove for compressing the loop around said round conductor and a flat portion for compressing the loop into engagement with said ribbon conductor intermediate its ends, and means for drawing said plates together.

In witness whereof, I have hereunto set my hand this 26 day of November, 1928.

REGINALD O. EATON.