

A. THOMPSON.
Ratchet Drill.

No. 102,066.

Patented April 19, 1870.

Fig: 1.

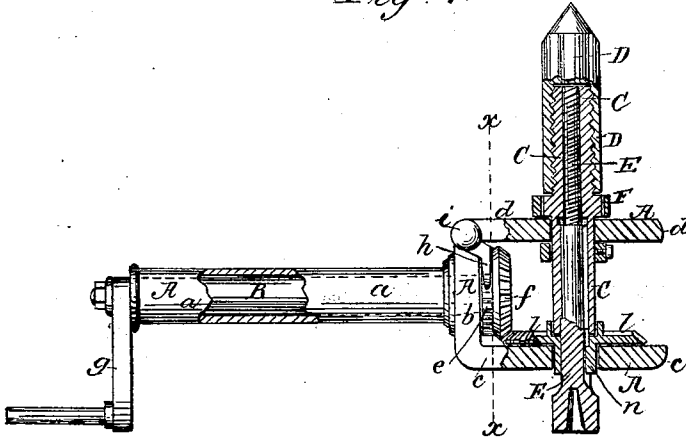

Fig: 2.

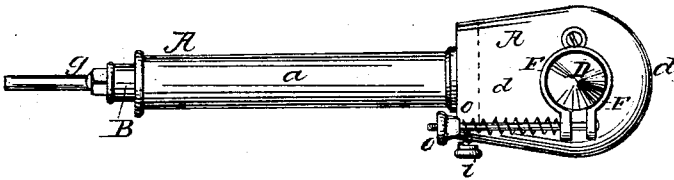
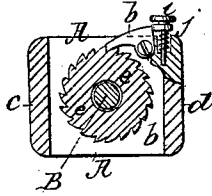

Fig: 3.



Witnesses
H. Decker
J. H. Brooks

Inventor
A. Thompson
PER. [Signature]
Attorney

United States Patent Office.

ALEXANDER THOMPSON, OF BURLINGTON, VERMONT.

Letters Patent No. 102,066, dated April 19, 1870.

IMPROVED DRILL

The Schedule referred to in these Letters Patent and making part of the same.

To all whom it may concern:

Be it known that I, ALEXANDER THOMPSON, of Burlington, in the county of Chittenden and State of Vermont, have invented a new and Improved Drill; and I do hereby declare that the following is a full, clear, and exact description thereof, which will enable others skilled in the art to make and use the same, reference being had to the accompanying drawings forming part of this specification, in which—

Figure 1 represents a side view, partly in section, of my improved drill.

Figure 2 is a plan or top view of the same.

Figure 3 is a detail vertical section of the same, taken on the plane of the line *x x*, fig. 1.

Similar letters of reference indicate corresponding parts.

This invention has for its object to so improve the device for holding rotary drills that the feed of the drill can be varied at will, and that also the drill and holder may be used in narrow places, where they otherwise could not be inserted.

The invention consists chiefly in the employment of a spring brake, by means of which the feed can be entirely arrested or regulated at will.

The invention consists also in a peculiar combination of the drill-holder with a tubular holder, driving-gear wheel, and feed-spindle, all as hereinafter more fully described.

A, in the drawing, represents the frame or holder of my improved tool.

The frame consists of a tube, *a*, and of a U-shaped plate, *b*, to the middle of which one end of the tube is secured, so that the ends or ears *c d* of the plate will be parallel with the tube, as shown.

Through the tube is fitted a shaft, B, which carries at its inner ends, *i. e.*, between the ears *c d*, a ratchet-wheel, *e*, and bevel-gear wheel *f*, its outer end being provided with a crank, *g*, as shown.

A click or pawl, *h*, is pivoted to the side of the frame, and catches into the ratchet-wheel, to prevent it from being revolved in the wrong direction.

The pawl may, by a screw, *i*, which is fitted through a backward-projecting arm, *j*, of the same, be thrown off the ratchet-wheel, to let the same revolve in every direction.

C is a tube, fitted through the two arms, *c d*, so that it can revolve freely in the same.

Around the tube is fitted loosely a gear-wheel, *l*, which meshes into the wheel *f*, and which, with its tubular shank, projects through the lower arm *c*, the lower end of the tube C having its bearing in the wheel, as shown.

The tube C projects above the upper arm *d*, and has a screw-thread cut upon its upper part, to receive the extending and contracting spindle D, which is screwed upon it.

Within the tube C is, furthermore, an internal

screw-thread, to receive the tool shank E, which is screwed into it.

The shank E has a groove, to receive a feather, *n*, that projects from the inner side of the wheel *l*.

The shank is thereby locked to the wheel, so that it must, under all circumstances, revolve with the same, although it can freely slide in the wheel.

The bit is fitted into the holder E.

When the shaft B is revolved, the wheel *l* will also be turned, and with it the holder E and the tool.

The holder being screwed into the tube and the tube into the spindle D, all these parts will, by the friction of the threads, be revolved with the holder, unless they are specially retained.

Thus, if the spindle D should be held by hand, and prevented from revolving, the tube C will revolve in it, and gradually become unscrewed, thus increasing the distance between the outer end of the spindle and the working end of the bit, thereby extending the length of the tool.

Again, if the tube C would be held fast, the holder would rotate in it, and be gradually unscrewed, to feed the bit.

The holding of the tube is produced by a spring-clamp, F, which is fastened to the upper plate *d*, and embraces the tube.

By means of a screw, *o*, it can be set to hold the tube more or less tight, and to thereby cause a greater or lesser feed of the holder.

By the double screw-thread on the tube, I can obtain a degree of extension about equally as long as the tube itself, provided the spindle and the screw-thread on E are each about half as long as C.

The advantages of this apparatus are, chiefly, that any suitable degree of feed can be obtained, and that the device can, in a contracted state, be introduced in places where it could otherwise not be applied. It can then be expanded at will.

Having thus described my invention,

I claim as new and desire to secure by Letters Patent—

1. The combination of tube C, spindle D, and holder E, all threaded, operated, and relatively constructed as set forth, and for the purpose specified.

2. The improved brake, formed of clamp F, the threaded rod, spring, and thumb-screw, all constructed and arranged upon the drill, as and for the purpose set forth.

3. The combination of wheel *l*, locked as described, with holder E, tube C, and spindle D, all relatively constructed as and for the purpose described.

4. The combination of clamp F with tube C, holder E, and wheel *l*, all constructed and operated together as specified.

ALEX'R. THOMPSON.

Witnesses:

T. E. WALES,
R. S. TAPP.