

Fig. 1.

Witnesses:

C. Hyman
 I. Spantikow

Inventor:

Adolf Bordt
 by B. Singer
 Attorney

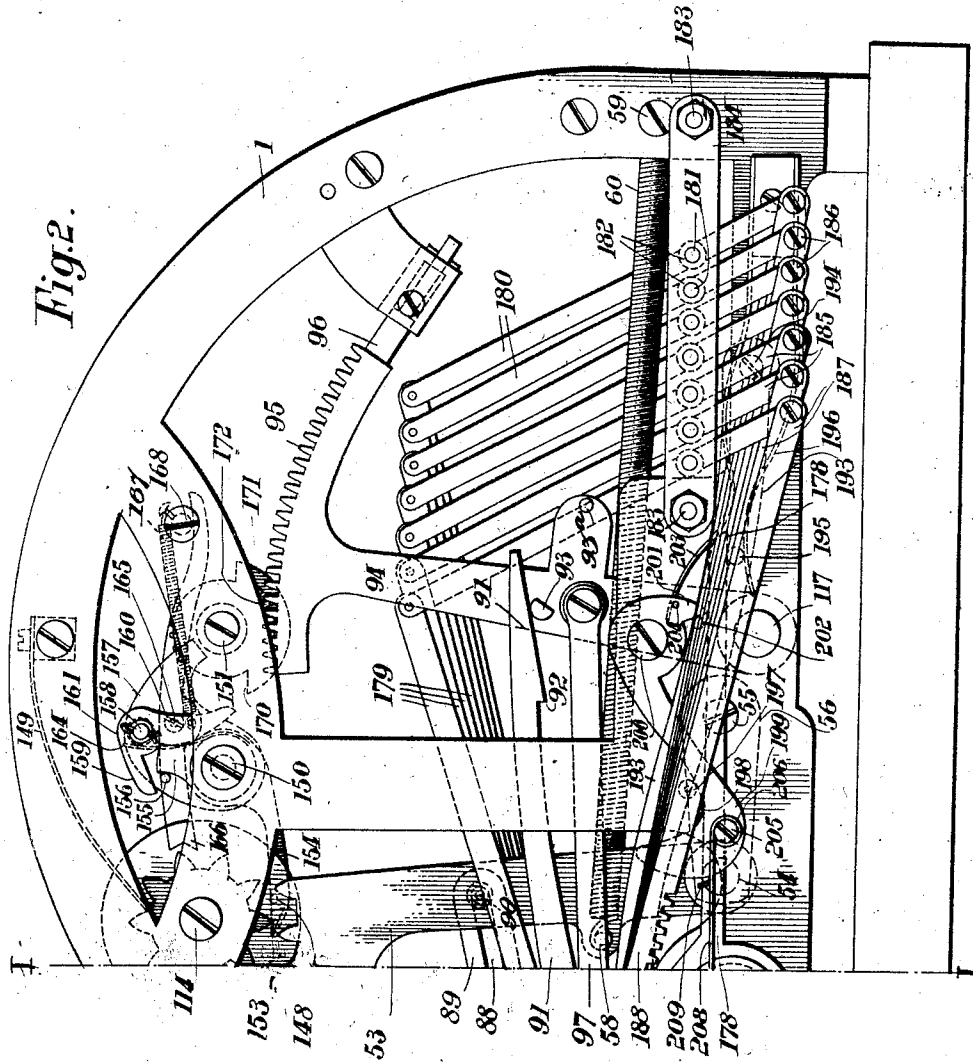

Witnesses:
C. Hymann
I. Spantikow.

Inventor.
Adolf Bordt
by B. Jinger Attorney.

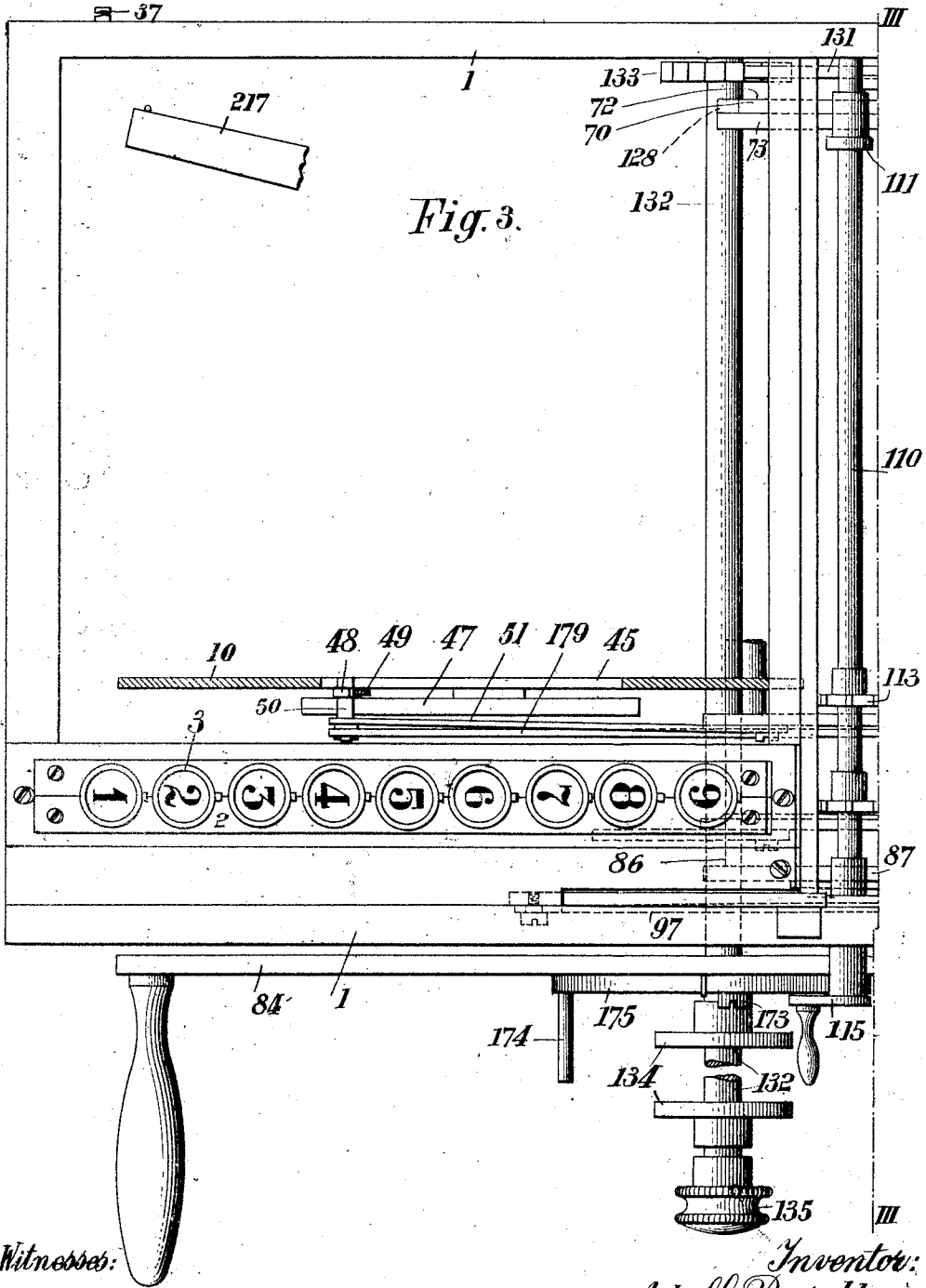

Witnesses:

C. Heymann
 J. Spantikow

Inventor:

Adolf Bordt
 by B. Singer
 Attorney.

A. BORDT.
 ADDING MACHINE.

APPLICATION FILED MAR. 25, 1909.

Patented Dec. 26, 1911.

12 SHEETS—SHEET 4.

1,012,976.

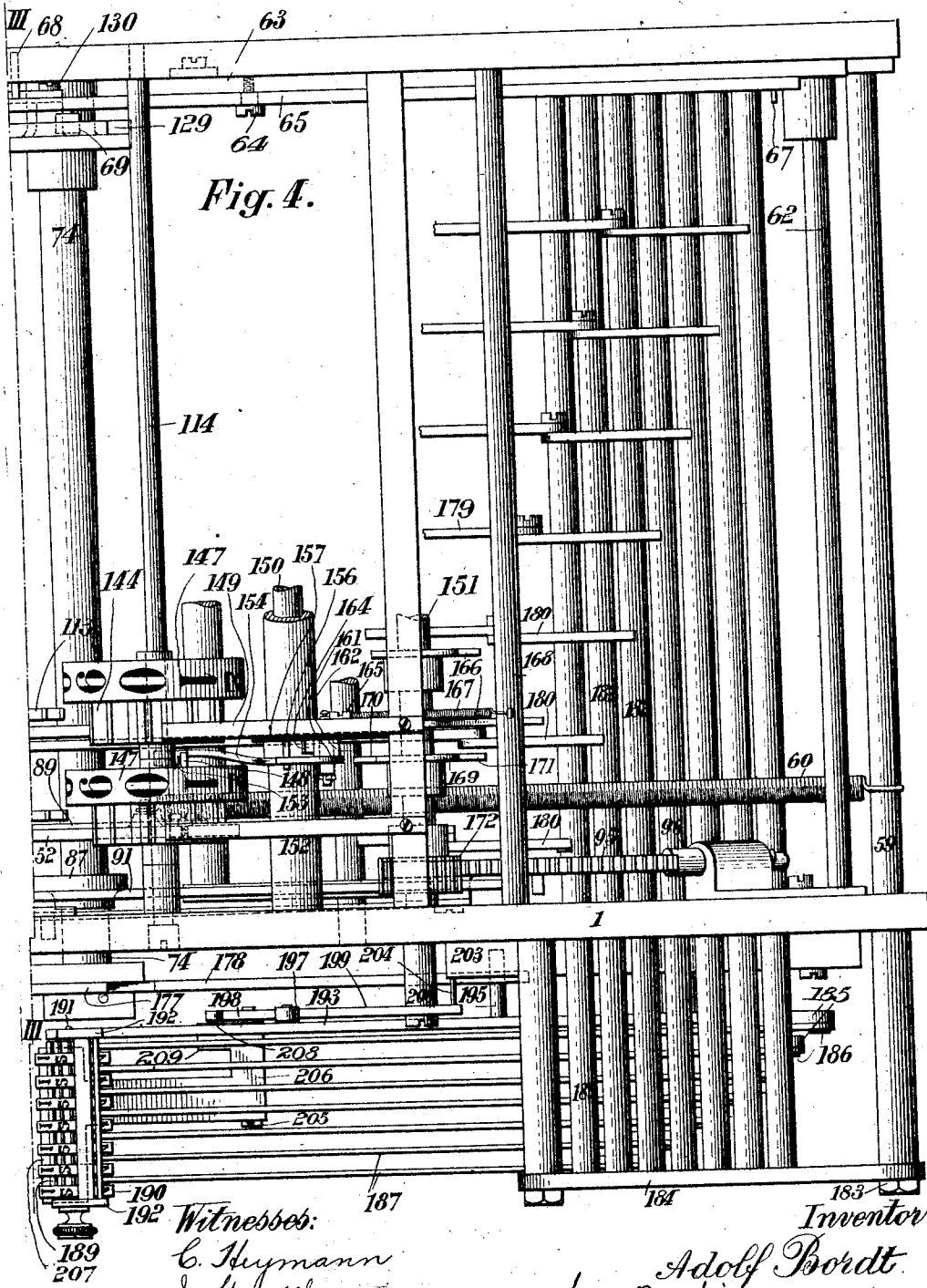

Witnesses:
 C. Heymann
 J. Spantikow

Inventor:
 Adolf Bordt.
 by B. Singer Attorney.

1,012,976.

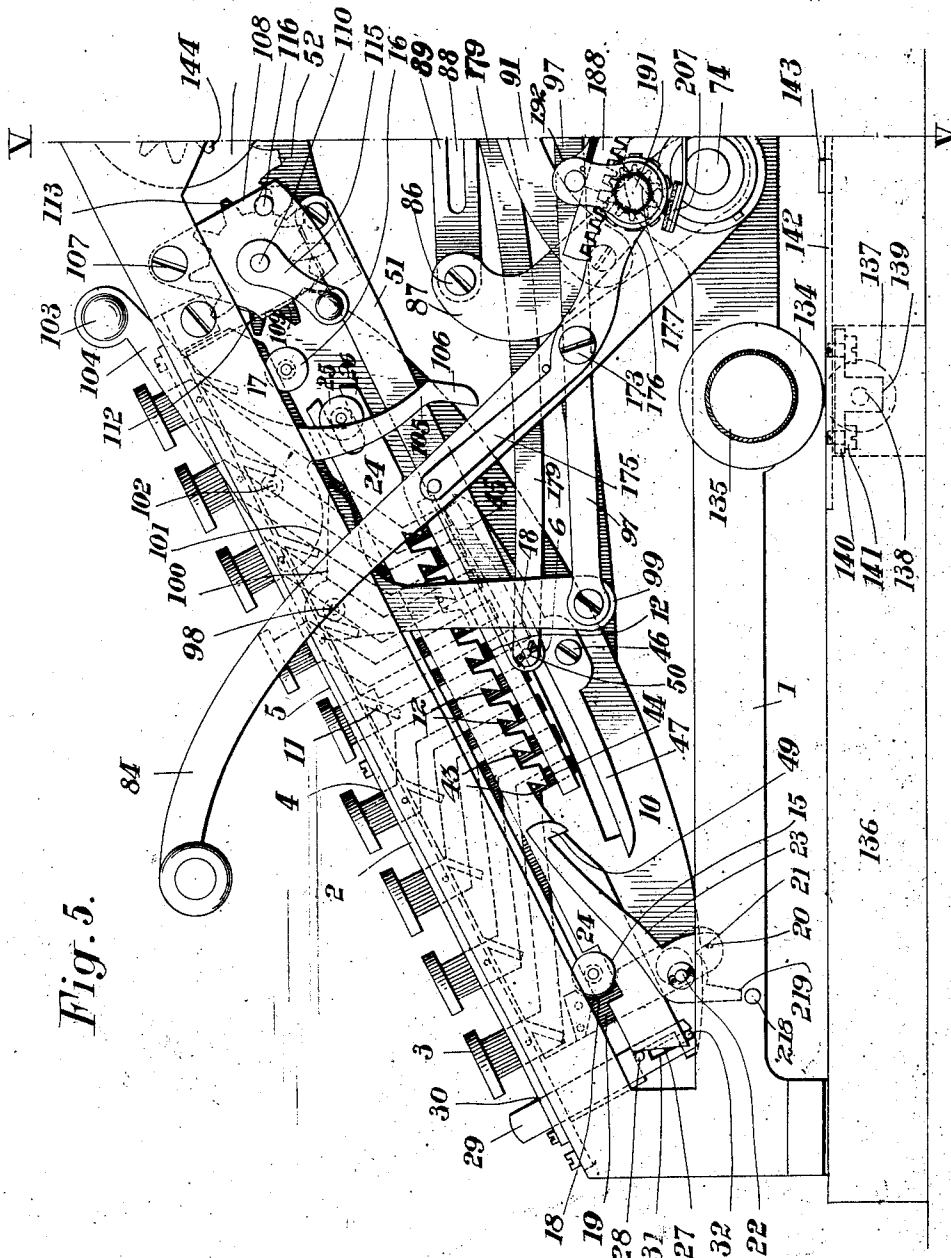

Fig. 5.

Witnesses:
 C. Heymann
 J. Spantikow.

Inventor:
 Adolf Bordt.
 by B. Linje Attorney.

1,012,976.

Fig. 6.

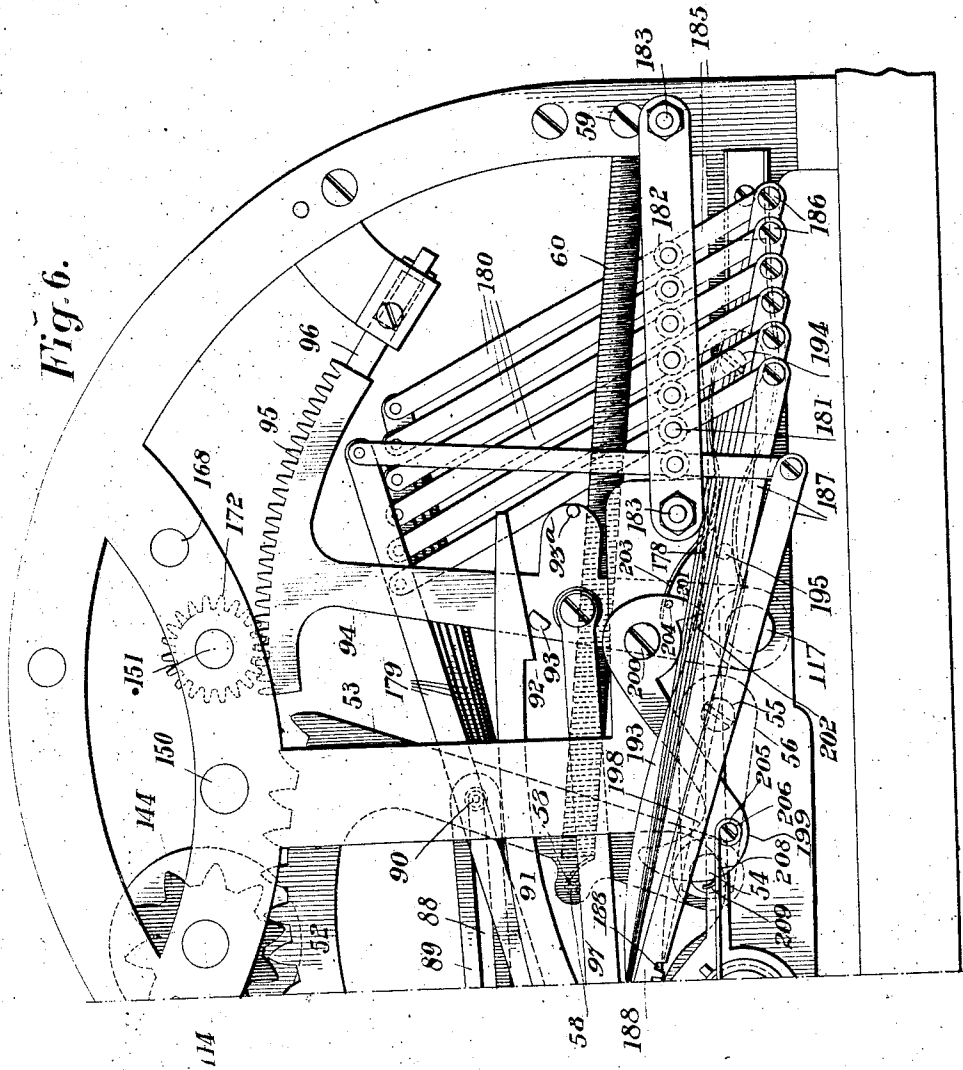

Witnesses:
C. Hermann
J. Spantikow

Inventor.

Adolf Bordt
by B. [unclear] Attorney

1,012,976.

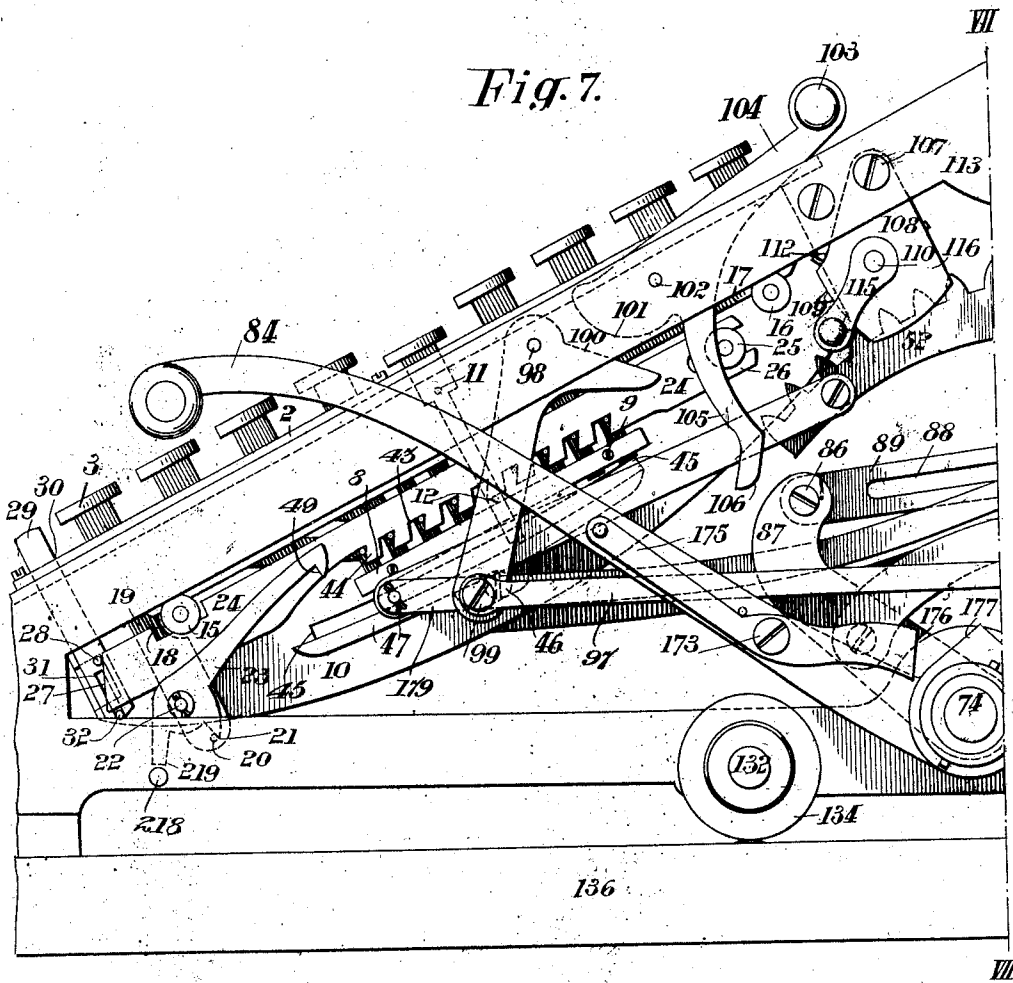

Witnesses:
C. Hymann
J. Spantikow

Inventor:
Adolf Bordt.
By B. Singer Attorney.

1,012,976.

A. BORDT.
ADDING MACHINE.
APPLICATION FILED MAR. 25, 1909.

Patented Dec. 26, 1911.
12 SHEETS—SHEET 8.

Fig. 8

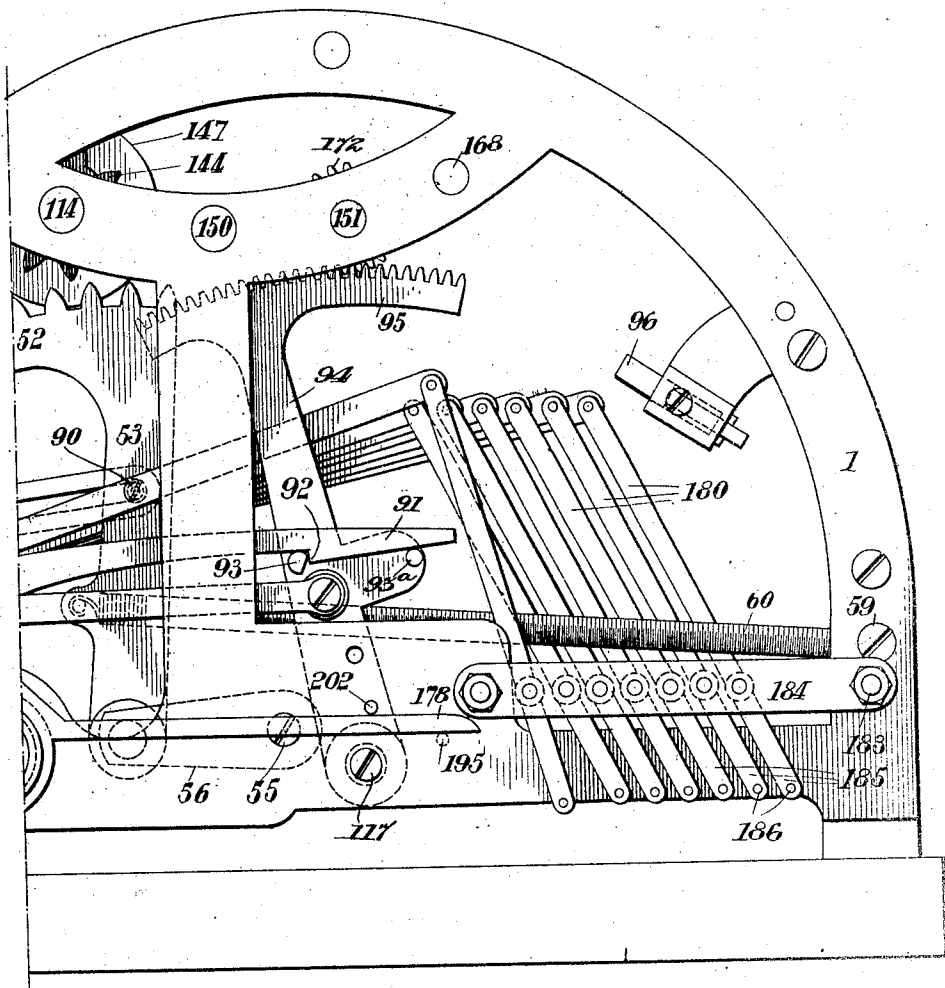

Witnesses:
C. Heymann
I. Spartikow.

Inventor.
Adolf Bordt
by B. Singer Attorney

Fig. 9

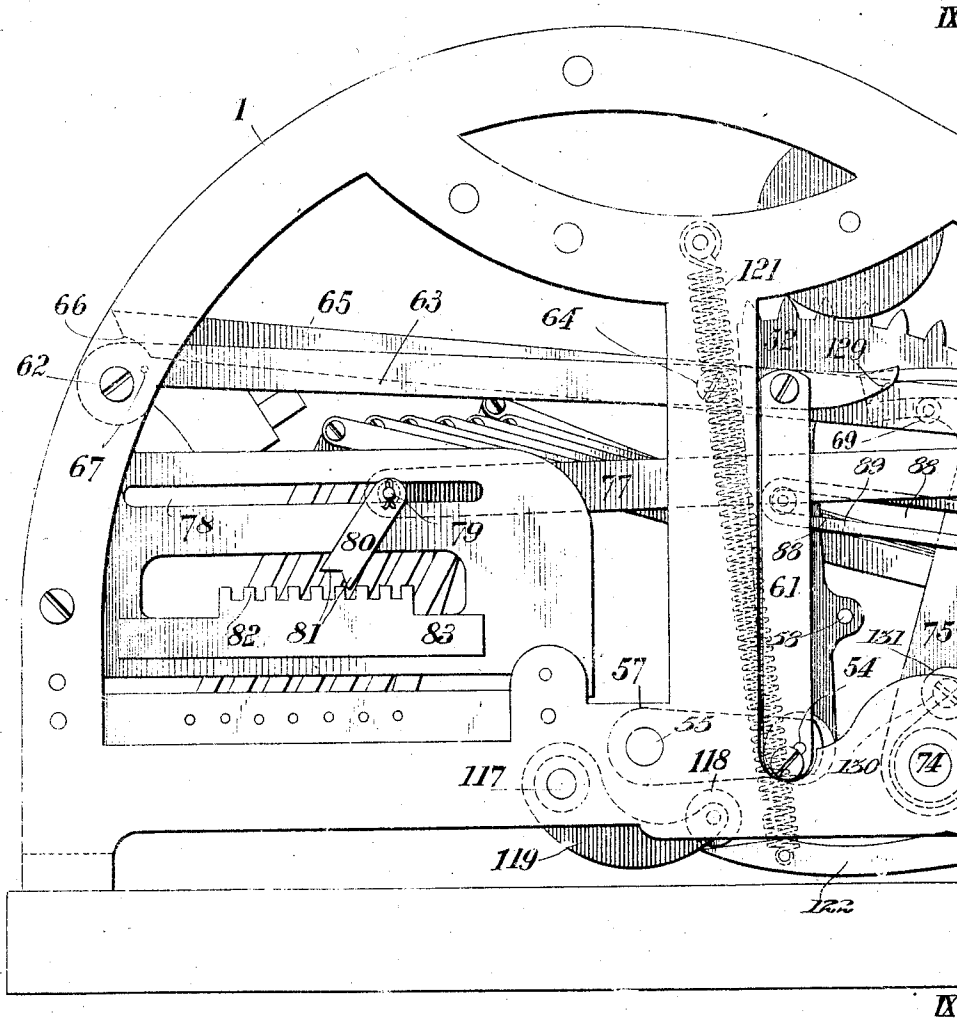

Witnesses:
C. Heymann
J. Spantikov

Inventor:
Adolf Bordt
by B. Linze Attorney.

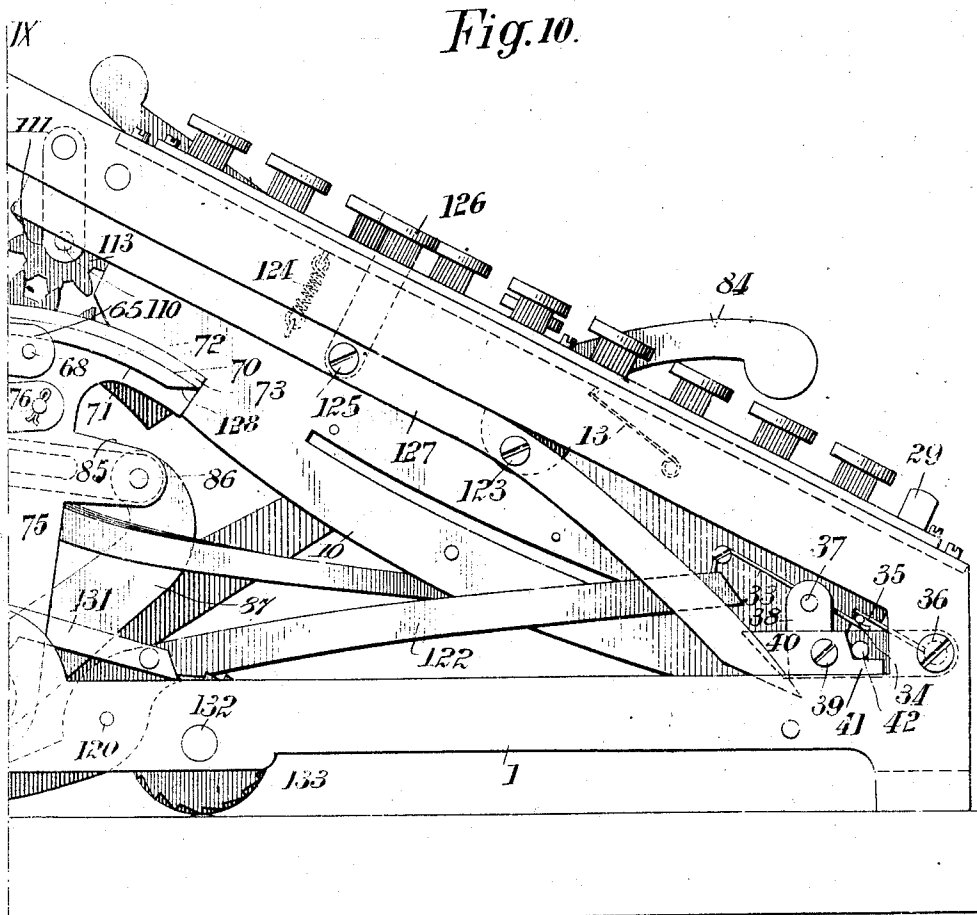

IX
Witnesses:
C. Heymann
J. Spantkem

Inventor:
Adolf Bordt
by B. Singer
Attorney

1,012,976.

A. BORDT.
ADDING MACHINE.
APPLICATION FILED MAR. 25, 1909.

Patented Dec. 26, 1911.

12 SHEETS—SHEET 11.

Fig. 13.

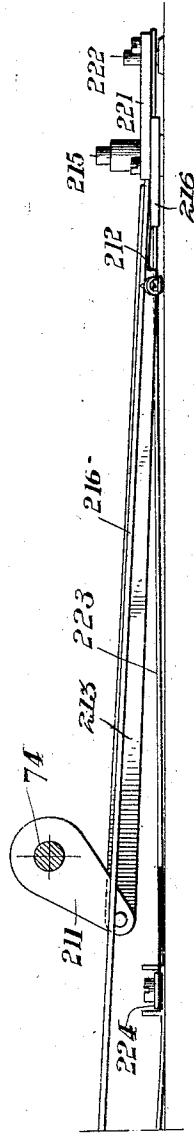
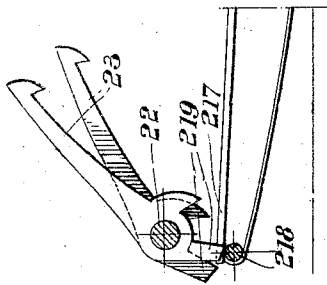
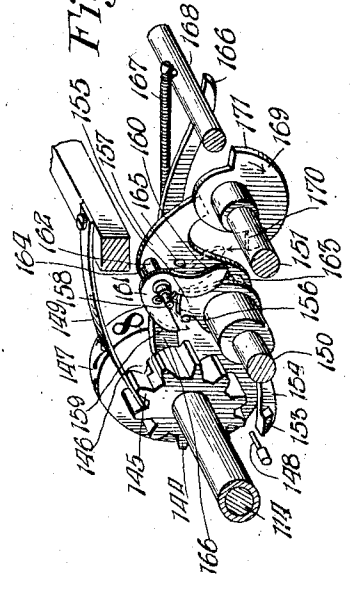

Fig. 11.



Witnesses:
 C. Heymann
 J. Spantikov

Inventor:
 Adolf Bordt
 by B. Linze Attorney

1,012,976.

A. BORDT,
ADDING MACHINE.
APPLICATION FILED MAR. 25, 1908.

Patented Dec. 26, 1911.

12 SHEETS—SHEET 12.

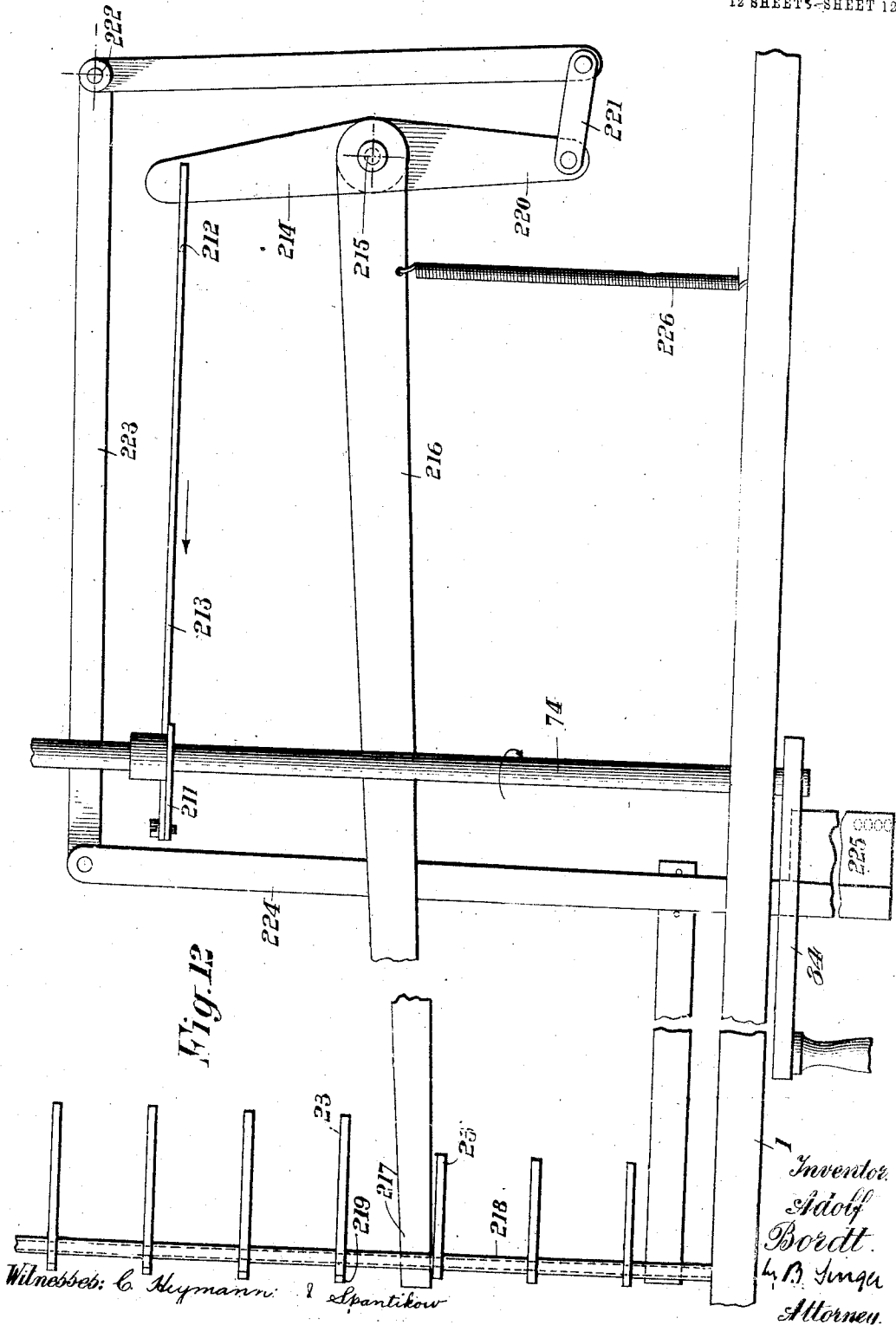

Fig. 12

Witnesses: G. Myrman & Spantikow

Inventor:
A. Bordt.
L. D. Ling
Attorney.

UNITED STATES PATENT OFFICE.

ADOLF BORDT, OF MANNHEIM, GERMANY.

ADDING-MACHINE.

1,012,976.

Specification of Letters Patent.

Patented Dec. 26, 1911.

Application filed March 25, 1909. Serial No. 485,592.

To all whom it may concern:

Be it known that I, ADOLF BORDT, a subject of the German Emperor, and resident of Mannheim, Germany, have invented certain new and useful Improvements in and Relating to Adding-Machines, of which the following is a specification.

One of the objects of this invention is to provide an adding machine which is arranged to add and print in accordance with the denominations of the keys operated, the said invention including means whereby the machine is arranged to print without adding or to add without printing.

One of the objects of this invention is to provide a system of adding wheels actuating racks normally under the influence of the springs and adapted, when a selected rack is released for operation to be moved into driving relation with the wheel of the adding device, to operate the same, when a main operating lever has been actuated.

An object of the invention is to provide a printing mechanism arranged to print upon an intermittently actuated strip the numbers of the keys which have been operated, and in this connection, the invention includes means for automatically preventing the printing of zeros in advance of the first numerals to the left of the line printed.

The invention has to do with improved devices for throwing out of operation the adding device and the printing mechanism so that either may be operated without the other.

A feature of the invention comprises automatically acting releasing means which may be operated automatically or manually and which is designed to release all of the depressed or actuated keys on the key board or any one of the operated keys of a single row of keys.

The invention also includes an improved automatic tens advancing mechanism for successively advancing the reading disks of the adding mechanism after any one of the same has reached a "nine" position.

The invention also includes other features and details of constructions which will be more fully described in connection with the accompanying drawings and which will be more particularly pointed out and ascertained in and by the appended claims.

In the drawings:—Figures 1 and 2 illustrate in side elevation, looking toward the right, a machine embodying the main fea-

tures of my invention with all of the parts shown in a normal or starting position. Figs. 3 and 4, together, illustrate a plan view, partly in section, of the machine shown in Fig. 1 with one row of keys and the operating mechanism therefor. Figs. 5 and 6, together, illustrate the machine in side elevation, as disclosed in Figs. 1 and 2, illustrating the parts as they would appear during the operation of adding and printing. Figs. 7 and 8, together, illustrate a view of the machine similar to the views shown in Figs. 1 and 2 with parts of the printing mechanism omitted. Figs. 9 and 10, together, illustrate the machine looking from the left hand side thereof. Fig. 11 is a perspective view of the adding mechanism and tens advancing device detached from the machine, parts being shown in section. Fig. 12 is a plan view of the improved device for preventing the printing of zeros in advance of the first numeral to the left of a line of printing. Fig. 13 is a sectional view thereof.

Like numerals of reference designate similar parts throughout the different figures of the drawings.

As illustrated, the machine is mounted on a base 136 and includes a frame, indicated as a whole by 1. The forward upper portion of the frame inclines forwardly and downwardly, as indicated at 2, to dispose the keys 3 in a position accessible to the user. The keys 3 are adapted to be arranged in rows across the key board or frame portion 2, but in order to simplify the drawings, only one row of keys is shown in Fig. 3. In the following description the parts necessary for one row of keys will be described and it will be understood that the parts for each row will be duplicated for each additional row of keys. The keys 3 extend through and are guided by apertures 4 in the key board 2, and as shown in Fig. 5, each key is provided with a shank extending downwardly from the key board and the central key shank is straight whereas the shanks of the remaining keys are formed so that their lower ends 6 are grouped closely together on opposite sides of the shank of the central key.

A key actuated bar 17 (Figs. 1 to 7) is provided with a plurality of slots 14 and is inclined in a plane parallel with the tops of the keys 3. In order to afford free movement of the bar 17 rollers 15 and 16 are pro-

vided for supporting the same and the bar 17 is arranged for movement on the rollers longitudinally in both directions. The tendency of the bar 17 is to move toward the front of the machine by gravity, as indicated by the arrow in Fig. 1.

There is a slot 14 for each of the keys and the slots 14 are inclined with their bottoms toward the front of the machine and are open at their upper portions to receive pin 11, one of such pins being provided for each key. When one of the keys is depressed its pin 11 enters an adjacent slot in the bar 17 and the wall of the slot acts as a cam and forces the bar 17 toward the rear of the machine.

A key locking bar 24 is disposed beneath the bar 17 and is shown forked or bifurcated at its upper end at 26 to engage on both sides of a roller 25. The lower or front end of the bar 24 engages the roller 15. The bar 24 is provided with a plurality of recesses 48 spaced apart so as to form therebetween teeth 44. The front faces of the teeth 44 are inclined and act as cam surfaces for pins 12 mounted on the shanks 6 of the keys 3. When one of the keys 3 is depressed its pin 12 acting upon the cam surfaces of the particular tooth 44 serves to move the bar 24 in the direction of the arrow (Fig. 1) until the pin 12 has reached the bottom of the tooth 44. After the pin 12 has reached the bottom of the tooth 44, as shown in Fig. 7, the bar 24 returns by gravity to its initial position and the pin 12 engages the bottom of the tooth 44 and serves to lock the depressed tooth in its lowered position. Movement of the bar 24 downwardly or toward the front of the machine is limited by the remaining pins 12 of the remaining teeth.

A releasing key, such for instance as indicated at 29, is provided for each row of the main keys for releasing any one key of such row from the locked position shown in Fig. 7. As illustrated in Fig. 7 the key 29 is guided through an opening 30 in the key board 2 and its lower end is bifurcated at 31 to receive a guiding pin 32. The lower or front end 27 of the bar 24 is inclined to provide a cam surface for engagement by a pin 28 on the releasing key 29. It should now be stated that the keys 3 are adapted to be held in their normal or upper position by springs 13 (Fig. 10) only one being shown. When the releasing key 29 is depressed the pin 28 moves the bar 24 in the direction of the arrow in Fig. 1 a sufficient distance to release the key 12 of the depressed keys, as shown in Fig. 7. The spring 13 of said keys will then raise the same to the position shown in Fig. 1 and the bar 17 will automatically return from the position shown in Fig. 5 to the position shown in Fig. 1 as the pin 11 leaves the slot 14. It will thus be seen that the releasing bar 17 and the locking bar 24

are both gravity acting and that they are both actuated in opposition to gravity to perform the functions hereinbefore set forth.

The releasing bar 17 is provided with an extension 19 having a recess 18, as shown in Fig. 1, to prevent engagement with the roller 15 and extending downwardly the said extension carries a pin 20. A slide lock lever 23 is pivotally mounted at 22 and is provided with a projection 21 adapted for engagement with the pin 20. The lever 23 is also provided with a latch projection 49 for engaging and locking a slide hereinafter described. Said lever 23 is also provided with a restraining lug 219 which lies immediately above a rod 218 when the lever 23 is in the position shown in Fig. 7 and which lies at one side of the rod 218 when the lever 23 is in the position shown in Fig. 1. It will be clear from the foregoing that when the bar 17 is moved upwardly, as shown in Fig. 5, the pin 20 will throw the lever 23 in an unlocking position and that when the bar 17 is in the position shown in Fig. 1 the pin 20 will permit the lever 23 to assume a locking position. The lever 23 assumes this locking position by gravity, in the construction shown.

Before proceeding with the description of the remaining parts of the machine reference will be made to devices for controlling the releasing keys 29, which devices are best shown in Fig. 10. A shaft 36 extends across the front of the machine and is provided with an arm 35 for each releasing key 29. Each releasing key 29 is provided with a pin 34 and each pin is provided with a spring 33. The springs 33 normally tend to return the releasing keys 29 to their normal or upper position. Said springs 33 engage the pins 34 from below and the arms 35 engage the pins 34 from above and serve, when the shaft 36 is rotated to the left, to depress the keys 29. When the shaft 36 is so rotated all of the releasing keys 29 of the entire key board will be depressed so as to release the main keys 3 and permit them to return to their normal or upper position by devices hereinbefore described. An angular lever 38 is keyed to the shaft 36 and carries the pin 37 and a pin 42. A dog 40 is pivotally mounted to the angular lever 38 at 39 and is provided with a projection 41 extending beneath the pin 42 and at its opposite end said dog 40 projects rearwardly beyond the angular lever 38. The means for throwing out of gear the adding mechanism includes a lever 127 having its forward end arranged to engage, on its upward movement, the pin 37 so as to throw the arms 35 out of engagement with the pins 34, by raising the part 38, thereby necessitating the individual depression of each of the key releasing keys 29 for each row when it is desired to return any of the main keys 3 to their normal posi-

tions. This adjustment is made when it is desired to print without adding. When it is desired to print and add the lever 127 is disposed in the position shown in Fig. 10 so that the dog 40 will be in the path of a lever 122. The lever 122 is arranged to be actuated at the completion of adding operation and its forward end is arranged for engagement with the dog 40 so as to depress the same and act through parts 38, 36 and 35 to depress all of the releasing keys in unison and automatically to return the main keys 3 to their normal position. The dog 40, as arranged, freely oscillates about the pivot 39 to permit the lever 22 to assume the position shown in Fig. 10, from a lower position, without operating the shaft 36. The mechanism and further functions relating to the levers 122 and 127 will be dealt with in the further description of the machine.

Returning to the locking lever 23 and referring to Figs. 1 to 8, inclusive, reference will be made to supporting plates 10 which are provided for each row of keys 3 and parts pertaining thereto. The plates herein shown, support the rollers 15, 16 and 25 and also the pivots 22. As shown in Fig. 1 the extension 19 is apertured to permit the pivots 22 to extend therethrough and also to permit movement of the extension 19. Said plates 10 also support a bar 8 secured thereto by screws 9, which forms a guide for the lower end 6 of the keys 3. In the plate 10 a slot 45 is formed to provide a bearing for a sliding pivot block 50 and the pivot 50 projects laterally from the plate 10 and the parts are so arranged that the movement of the pivot 50 will be intercepted by the lower end of any one of the keys which are depressed as clearly shown in Fig. 7. When in the position shown in Fig. 1 the pivot block 50 is locked by the lever 23 and is engaged by the latch 49 thereof. A bearing member 47, secured at 46 to the plate 10, is provided for supporting the pivot block 50 in a to and fro movement. In Fig. 3 parts shown below the key board including the plate 10 are for the next adjacent row of keys to the left of the keys 3 herein shown and it will be understood that the keys 3 are provided with mechanism of a similar nature located beneath the same. The pivot block 50 is shown connected by a link 51 with one of a system of adding wheel actuating racks 52 which is herein shown as having the form of a segment. This segment rack 52 is mounted upon an arm 53 which is loosely disposed upon a shaft 54 extending across the machine so as to support all of the segments 52. Each segment 52 is operated by a spring 60 connected by a shaft 59 extending across the machine as shown in Fig. 4, and which may be connected with the arm 53 by a pin 58 thereon. The springs 60 are arranged to rock the

segments rearwardly. It may here be stated that after one of the keys 3 has been depressed the locking lever 23 of such row is raised and the springs 60 will rock the rack segments 52 and the latter, acting through the links 51 will move the pivot block 50 in the slot 45 until such movement is arrested by the lower end 6 of the depressed key as shown in Fig. 7 wherein is illustrated a partial movement of the pivot block 50. The adding mechanism will be briefly referred to as including toothed wheels 144 with which the segment racks 152 are adapted to be thrown into mesh there being a segment rack 52 for each row of keys and a toothed wheel 144 for each row of keys. In the present invention the segment racks are normally out of mesh with the wheels of the adding mechanism and are automatically thrown into mesh therewith, if the adding mechanism is intended to be used.

The construction and arrangement whereby the segments 52 are thrown into and out of mesh with the wheels 144 includes arms 56 and 57, the arm 56 being on the left hand side of the machine and the arm 57 on the right hand side thereof. The arms 56 and 57 carry at their free ends the shaft 54 on which the arms 53 are loosely mounted, and at their rear ends, said arms 56 and 57 are pivoted at 55. A main controlling shaft 74 carries the main operating lever 84 for simultaneously actuating various elements and mechanisms of the machine, as hereinafter more particularly specified, (Figs. 1 to 8) and extends across the frame of the machine. On the left hand side of the machine (Figs. 9 and 10) an arm 75 is rigidly secured to the shaft 74 and carries on its upper end a segment cam 72 having an upper cam surface 70 and a lower cam surface 71. At the ends of said surfaces 70 and 71 transfer cam surfaces 128 and 129 are provided so as to form, with said cam surfaces 70 and 71 a complete or continuous cam surface. By reason of the fact that the arm 75 is rigidly secured to the shaft 74 said arm will always be operated when the main operating lever 84 is operated. A lever 63 (Figs. 3, 4, 9 and 10) is pivotally mounted at 62 to the frame of the machine and is provided with a stop pin 67 near the pivotal mounting 62. The forward or free end of said lever 63 is connected by a link 61 with the arm 57 for the purpose of lifting the shaft 54 or permitting the same to lower. An auxiliary lever 65 is pivoted to the lever 63 at 64 and its rear end is limited in its downward movement by the pin 67. The forward end of said auxiliary lever 65 carries a roller 69 adapted to cooperate with the continuous cam surfaces 70, 71, 128 and 129. When the adding machine mechanism is not to be operated the roller 69 rides upon the cam surface 71 and this

maintains the shaft 54 in its lowermost position so that the segment 52 will be out of mesh with the wheel 144. When the adding mechanism is to be operated the roller 69 rides upon the cam surface 70 so as to raise the shaft 54 and bring the segments 52 into mesh with the wheels 144. When the main operating lever 84 is in its extreme forward position, as shown in Fig. 1, the arm 75 carrying the cam 72 will be advanced to the right of Figs. 9 and 10 a sufficient distance to bring the transfer cam portion 129 abreast of the roller 69. The incline of the cam portion 129 will cause the roller 169 to normally ride up on the cam surface 129 and on to the upper face 70. This would take place upon movement of the arm 75, (Figs. 9 and 10) to the left and this would raise the shaft 54 through links 61 and bring the racks 52 into mesh with one of the toothed gears 144. By reason of the fact that the cam surface 129 is very short and abrupt it will be readily seen that the shaft 54 will be lifted to bring the rack 52 into mesh with the wheels 144 almost simultaneously with rearward movement of the rack under the action of spring 60. It may be stated that when the roller 69 rides upon a transfer cam surface 129 the rear end 66 of the lever 65, will engage the pins 67 and the pivot 62 will form the center about which the levers 65 and 63 swing in raising the shaft 54 to bring the segments 52 in mesh with the gears 144.

In the preferred construction reliance is not placed upon the cam surface 129 for raising the shaft 54 to the links 61 and roller 69, although it will appear that the end 66 of the lever 65 will act by gravity to raise the roller 69 a sufficient distance to insure its engagement with the transfer cam 129, but I preferably provide a spring 121 for insuring rising movement of the lever 63. Spring 121 is connected at one end with the frame of the machine and at its other end with the lever 122, hereinbefore described, and which lever is pivotally mounted at 120 upon the frame of the machine. The rear end of the lever 122 engages a roller 118 mounted upon an arm 119 which is keyed to shaft 117. The shaft 117 is mounted in the frame of the machine and extends transversely therethrough. It will be readily seen that when the spring 121 raises the inner end of the lever 122 the latter will act through the roller 118 upon the arm 117 to raise the same and likewise the shaft 54. It may be stated, at this point, that the spring 121 and lever 119 and shaft 117 are for the purpose of performing additional functions which will hereinafter more fully appear.

As will hereinafter appear, it is necessary that the main operating lever should be swung in either one or other of the direc-

tions in which it is moved to the limit of its travel so that it cannot be moved backwardly, for a portion of its travel and then returned but must always be moved to the limit of its travel or swing. To provide for this operation a link 77 is connected with the arm 75 at 76 and at its opposite end said link is provided with a pivot 79 which slides in a slot 78, formed in a part of the frame work. A pawl 80 preferably provided with a V-shaped end 81 is pivotally mounted at 79 and loosely rides upon teeth 82 of a bar 83. Referring to Figs. 9 and 10 it will be seen that the lever 84 has not reached its full forward movement and therefore the pawl 80 engages the teeth 82 and would prevent movement of the lever 84 to the left of said figure. When the lever 84 has reached its full forward movement the pawl 80 will have passed beyond the extreme right tooth 82 and will hang vertically and idly from the pivot 79. This will admit of the lever 84 being swung to the left or rearwardly, with regard to said figure. The same operation follows and it will be clear that when the lever 84 is swung rearwardly it must be swung to its full limit of travel before the pawl 80 is released from the teeth 82. Now when the lever 84 has swung to its extreme rearward limit of movement and the roller 69 is traveling on the surface 70, or upper surface, then the end of the cam will pass beneath the roller 69 and the latter will be permitted to drop below the end of the surface 70 and will ride downwardly on the transfer cam surface 128 on to the lower surface 71. The action on the other end of the cam 72, with respect to the cam 129, has already been described and one of the principal functions of the pawl 80 is to insure the full movement of the lever 84 so as to effect transfer of the roller 69 from the upper cam surface 70 to the lower cam surface 71 or vice versa.

It has been stated that the rack segments are moved rearwardly by the springs 60 and now the means whereby the return movement of the rack segments 52 against the action of the springs 60 is effected.

On the shaft 74 is rigidly mounted an arm 87 which is connected at 86 with a link 89 having a slot 88. The slotted link is connected with a pin 90 on the arm 53 of the segment 52. By reference to Figs. 1 and 2 it will be seen that the segments 52 cannot be moved rearwardly under the action of the springs 60 until the lever 84 has been moved rearwardly. The end of the slotted portion 88 is in engagement with the pin 90. It may be stated that after the locking lever 23 has released the slide block 50 it is not desirable to have the segment 53 actuated by the springs 60 until it has been raised into mesh with one of the wheels 144. Now when the parts are in the posi-

tion illustrated in Figs. 1 and 2 the roller 69 will be in a position to ride up on the transfer cam surface 129 and when the lever 84 is moved rearwardly the cam 72 is likewise moved rearwardly so that the roller rides upon the surface 70 and lifts the segments 52 into mesh with a wheel 144. The segment 52 then travels rearwardly until the slide block 50 engages the shank 6 of the particular key 3 which has been depressed and then the segment 52 is arrested in its rearward movement. However the slot 88 permits the controlling lever 84 to continue its movement rearwardly to the extreme limit and when the lever 84 is again returned to its forward limit of travel the ends of the slot will engage the pin 90 and likewise return the segment 52 to its forward position so that the slide block 50 will be locked by the lever 23. Owing to the fact that the cam 72 makes a complete movement to the rear, together with the lever 84, the roller 69 will always ride off from the ends 70 and pass to the lower cam surface 71 at each rear movement of the lever 84, thereby preventing the segment 52 from disturbing the position of the adding wheels which has been effected during the rearward movement of the segment 52, while said segment is undergoing its forward movement. It will thus be apparent that the segment 52 is thrown into mesh with one of the adding wheels 144 at each rearward movement of the segment (when it is desired to operate the adding mechanism) and that each forward movement of the segment 52, and at the beginning thereof said segment is thrown out of mesh with the wheels 144. At this point it may be well to describe how the adding mechanism is thrown out of gear when desired.

Referring to Figs. 9 and 10 it will be seen that the auxiliary lever 65 carries a pin 68 at its forward end. The pin 68 lies in the path of the rear end of the lever 127, hereinbefore referred to, and which is pivoted at 123 to the frame of the machine. The lever 127 is pivotally connected at 125 with a throw-out key 126 and is normally held in the position shown in Fig. 10 by spring 124. When the key 126 is depressed the rear end of the lever 127 engages the pin 68 and forces and holds the same downwardly, raising the end 66 of the lever 65, so as to prevent the roller 69 from engaging the transfer cam 129 and riding on to the upper surface 70 of the cam 72. By means of this adjustment the shaft 54 is not elevated during the rearward movement of the lever 84 and therefore the segments 52 are not raised into mesh with the gears 144 and the adding mechanism is not operated. The segments 52 merely move idly under the action of springs 60 to the rearmost position in accordance with the keys 3 depressed

and are idly returned when the lever 84 is moved to its forward position by the arm 87 and the link 89. As has been hereinbefore set forth, the depression of the key 126 raises the forward end of the lever 127 into engagement with the pin 37 and thereby rotates the shaft 36 so as to raise all of the arms 35 out of engagement with the pins 34. In this adjustment the keys of each row must be released independently by manually operating the release key 29 of the row from which keys are to be released. The purpose of this arrangement will more fully appear during the description of the printing mechanism but may be briefly stated as follows:—When printing numbers it is frequently desired to retain a number of keys in a depressed position for printing a new line of figures because the same figures are to be repeated. It will thus be seen that the automatic release of all of the keys 3 at the end of each printing operation would needlessly require the operator to again depress the number of which he wished to repeat. If it was desired to print 1222 and if it were next desired to print 1223 the operator would not desire to change the “hundreds 2” or the “thousands 1” but would merely want to repeat them with the “unit 3.” In the adjustment hereinbefore described this can be done without again depressing the keys designating the numbers which it was desired to print. For the sake of clearness it may be well to also state that each complete operation of the lever 84, irrespective as to whether the adding mechanism or the printing mechanism are separately thrown out of gear or both used, the lever 122 at its forward end moves upwardly and then downwardly. Now when the adding mechanism is thrown out by depressing the key 126 the dog 40 is elevated so that the up and down movement of the forward end of the lever 122 will not in any way affect the adjustment resulting from depression of the key 126.

The adding mechanism and the tens carrying forward device will next be described in detail and reference will be made to Figs. 2, 4 and 11.

A shaft 114 is mounted in the frame 1 and extends transversely thereof and carries toothed wheels 104 and reading disks 147, for each row of keys. On the periphery of the reading disks 147, numerals 0 to 9 appear and the reading disks 147 and toothed wheel 104 for each row of keys are connected together to rotate in unison. A flat spring 149 engages the teeth of the wheels 144 to prevent movement thereof in either direction, accidentally after such wheel has been adjusted by a segment 52 to the desired position. Each wheel 144 has ten teeth and one of the teeth 145, is

cut away at 146, as clearly shown in Fig. 11. This mutilated tooth 145 should appear opposite the numeral 9 on the disk 147. Each reading disk 147 is provided with a pin 148 projecting toward the next adjacent toothed wheel 144, and which moves with the disk 147 in the direction of the arrow, as shown in Fig. 11. Said pin 47 is arranged for engagement with an enlargement 153 of an arm 54, and beneath the same, to raise the arm 54 while the pin 148 is passing beneath the enlargement or cam surface 153. Immediately after the pin 148 has reached the right hand end of the cam surface 153 the arm 154 is permitted to descend in the position shown in Fig. 11. The arm 154 is mounted upon a sleeve 152 carried by shaft 150, which shaft is mounted in the frame of the machine and extends transversely thereof. The sleeve 152 carries a cam projection 155 adapted for engagement with a pin 156 to limit movement of the sleeve 152 and arm 154 in a contra-clockwise position, under the action of gravity. The cam projection 155 engages, or is adapted for engagement with, one end 160 of an idler trip 161 mounted upon a pivot 158. The pivot 158 is carried by the member 157 which will be presently described. The trip 161 is provided with a sleeve 162 which is engaged by a spring 164 mounted upon a sleeve 163 (Fig. 11) to retain the idler trip 161 in its adjusted position and frictionally hold it in such position. The pivot 150 is carried by an oscillating member 157 mounted on the sleeve 163 which latter is mounted on the shaft 150.

The oscillating member 157 carries a ten advancing element or pawl 166 which is pivotally mounted on the part 157 at 165. A spring 167 attached to a shaft 168, mounted in the frame 1 of the machine, is also connected with the member 157 and normally holds it in the retracted position shown in Fig. 11. The forward end of the ten advancing element 166 is notched for engagement with one of the teeth of the wheel 144 and the rear end of said elements extends beneath the shaft or rod 168. By reason of the fact that the pivot 165 is at one side of a vertical line intersecting the center of the shaft 150, and in view of the fact that the rear end of the element 166 is held downwardly by the shaft 168, it will be apparent that when the member 157 is advanced forwardly, or in a contra-clockwise direction, the forward end of the element 166 will not only have a forward but an upward movement imparted thereto for the purpose of turning the toothed wheel 144 the distance of one tooth. On shaft 151, which is mounted in the frame of the machine and extends transversely thereof, is a cam 169 having acting cam surfaces or shoulders 170 and 171

between which is a relatively reduced concentric surface and a relatively increased concentric surface, the latter verging at the outer ends of said shoulders 170 and 171 (Fig. 11). When one of the reading disks 147 is to be advanced one tooth to carry forward the tens the pin 148 will engage the bottom of the enlargement 153 and raise the arm 154 and thereby causing the projecting cam portion 155 to swing the end 160 of the trip 161 into the path of the working shoulder 170 of the cam 169. Now the end 160 will ride upon the enlarged concentric surface of the cam 169 during rotation thereof in this direction of the arrow, Fig. 11. This will shift the member 157 forwardly toward the wheel 144 against the action of spring 167 and cause a forward and an upward movement of the element 166 thereby engaging the same with a tooth of the wheel 144 and rotating the wheel a distance equal to one tooth. Such forward movement of the element 157 it will be understood is really an oscillatory movement about the shaft 150 at the center. The cam 169, during this operation, is arranged to rotate in the direction of the arrow for approximately three-quarters or seven-eighths of a revolution. After this partial operation is completed the cam 169 is reversed so that the reduced portion will be adjacent the end 160 thereby permitting the spring 167 to retract the member 157 and also the element 166. The reverse rotation, or that rotation opposite to the direction indicated by the arrow, of the cam 169 will be sufficient to bring the working surface 171 into engagement with the end 160 of the trip 161 so as to return it to the full line position shown in Fig. 11, after the spring 167 has returned the parts to the position shown in Fig. 11 or Fig. 2. When the part 160 has been returned to the full line position shown in Fig. 11 it acts upon the cam projection 155 and also returns the arm 154 in such a position that the enlargement or cam 153 will be in the path of the pin 148 during the next ten advancement.

The manner in which the shaft 151 is actuated to give the reverse rotation to the cam 169, and also other mechanism in connection, with these parts will now be described in detail.

The shaft 117 carries an arm 94, which is rigidly secured to said shaft, and which is provided at its upper end with a segment rack 95 adapted to and arranged to be always in mesh with a pinion 172 mounted on shaft 151. The spring 121, connected with lever 122, holds the latter in connection with roller 118 carried by arm 119, which latter is rigidly mounted on shaft 117, and therefore the spring 121 normally holds the arm 94 against an abutment 96 and serves to always yieldingly return said arm 94 to the normal or starting position shown in Fig. 2. A

latch hook 91 is pivotally secured to arm 87 which is rigidly mounted on shaft 74 and the hook has a latched shoulder 92 adapted for engagement with a pin 93 on the arm 94.

5 A throw-off pin 93^a is also mounted on the arm 94 and serves to throw the latched end of the hook 91 out of engagement with the pin 93 when the arm 94 has moved slightly forwardly beyond the position shown in Fig. 8. It will thus be seen that in starting to

10 act the arm 94 will be in the normal starting position against the abutment 96 and when the main operating lever 94 has reached approximately the rearward limit of its movement the latched end of the hook 91 will en-

15 gage the pin 93 so that upon the return or forward movement of the lever 84 the arm 94 will be moved forwardly. Now on the forward movement of the arm 94 the pinion

20 172 will be turned in a clock-wise direction as indicated by the arrow in Fig. 11 on the cam 169. This will cause the part 170 to engage the end 160 and operate the ten advancing mechanism. As hereinbefore stated

25 the wheel 172 and the cam 169 will be rotated in a clockwise direction slightly less than a complete revolution by the forward movement of the arm 94. Now it has been stated that after the ten advancing mechanism has been operated it is necessary to

30 throw the trip 161 into a non-acting position out of the path of the part 170. This is accomplished by reason of the fact that when the lever 84 in its return movement approaches the forward limit of its swing the

35 latch 91 will be disengaged from the pin 93 by the pin 93^a. This will place the arm 94 under action of the spring 121 and the latter will return the arm 94 to the abutment 96.

40 This return movement of the arm 94 will rotate the shaft 151 in a contra-clockwise direction, so that the acting surface 171 of the cam 169 will throw the trip 161 into the full line position shown in Fig. 11 so that it will

45 be out of an acting position with respect to the cam 169.

After the completion of each adding operation it is necessary to return the reading disks 147 to a zero position and therefore

50 means are provided for returning said disk to a zero position and preferably said means is normally out of engagement with the adding mechanism. As shown, parts 108 and

55 111 carry a shaft 110 (Figs. 7 and 3) which shaft extends throughout the width of the machine. The shaft 110 carries a plurality of toothed wheels 113 arranged so that one wheel on shaft 110 will mesh with one of the wheels 144, there being

60 a wheel 113 for each wheel 144. A crank 115 is mounted on the shaft 110 so that it can be manually operated when the wheels 113 are thrown into mesh with the wheels 144. A stop pin 116 may conveniently be

65 arranged on the part 108 to limit movement

of said part about the pivot 107. The part 108 is provided with a cam surface 109 adapted to be engaged by the end 106 of a lever 105. The lever 105 is pivoted at 102

70 in the frame of the machine and has an extension 104 provided with a handle 103 and also has a cam surface 101. When the lever 104 is swung about its pivot to bring the end 106 in engagement with the cam surface 109

75 the part 108 is swung rearwardly to bring the wheels 113 to mesh with the wheels 144. After the wheels 113 have been brought into mesh with the wheels 144 and the reading disks have been returned to a zero position then the parts which carry the shaft 110

80 will return to the position shown in Fig. 7 by gravity, after the lever 104 has been returned to the full line position shown. The cam surface 101 is adapted for engagement with a cam extension 100 formed on a lever

85 99. The lever 99 is pivoted at 98 to the frame work 1 of the machine and is connected by a link 97 with the arm 94. Now (referring to Figs. 1, 2, 5, 6, 7 and 8) it will be apparent that when the arm 104 is swung

90 forwardly to throw the wheels 113 in mesh with the wheels 144 the cam 101 will engage the cam extension 100 and swing the arm 94 forwardly. The reason for this operative connection between the arm 104 and the arm

95 94 is as follows:—When the wheels 113 return the reading disks 147 to their zero position the pins 148 will engage the cams 153 (Fig. 11) and throw the trip 161 into the path of the actuating surface 170 of the

100 cam 169. If, in the following operation of addition, the tens carrying or advancing device be actuated upon the first movement of the wheels 144, this would result in an inaccurate addition. Now by reason of the

105 connection hereinbefore described the arm 94 rotates the cam 169 to bring the reduced surface thereof adjacent the trip 160 while the arm 94 is swung forwardly by the link 97. After the reading disks have been set to

110 a zero position and the arm 104 has been returned to the position shown in Fig. 7 then the trip 160 will be in the path of the actuating surface of the cam 169 ready to be

115 tripped thereby. However when the arm 94 has been released by disengagement of the cams 101 and 100 and when the arm 94 is returned by the spring 121 to the abutment 96 it will rotate the cam 169 in a contra-clock-

120 wise direction and cause the actuating surface 171 to engage the end 160 and throw it from the dotted line position in Fig. 11 to the full line position in Fig. 11. Now all of the parts are in their normal or starting

125 position and the next operation of addition can be initiated and accurately carried out.

Reference will next be made to the printing mechanism and to the arrangement whereby it may be either operated or thrown

130 out of operation.

As will be seen by reference to Fig. 4 the printing mechanism is located outside of and to the right of the frame of the machine. Said mechanism includes printing wheels 190 on the periphery of which the printing characters are disposed, and toothed pinions 207, one for each printing wheel. The pinions 207 and printing wheels 190 are mounted upon a common shaft 191 and this shaft is carried in a frame 192. The frame 192 is supported upon an arm 193 which is pivotally mounted at 194 to the frame of the machine (Figs. 2 and 6). For each pinion 207 there is an operating bar 187 provided with teeth 188 adapted to mesh with the pinions 207. The operating bars are for the purpose of rotating the printing wheels to bring the proper character into a printing position prior to the actuating of the printing mechanism to effect the impression. The opposite or rear end of the bars 187 are pivotally connected at 186 with arms 185 formed on sleeve 182. The shafts 181 extend through said sleeve and transversely across the machine and find bearings at the right of the machine in a bar 184 and in the machine frame, as clearly shown in Fig. 4. The sleeves 182 extend through the machine as shown in Fig. 4 and each of the sleeves carries an arm 180 which are pivotally connected to connecting bars 179. There is a connecting bar 179 an arm 180 and an arm 185 and an operating bar 187 for each row of keys. For the row of keys shown the extreme right hand bar 179 is connected with the pivot or sliding block 50, as shown in Figs. 1 and 5. When the sliding block 50 is moved in the slot 45 under the action of a spring 60 such movement is transferred from the bar 179 to the corresponding operating bar 187, and the extent of movement of the sliding block 50 is transmitted to the particular printing wheel so as to rotate the same a distance sufficient to bring the denomination on the printing wheel corresponding to the denomination on the key depressed into a printing position. In Fig. 5 the key bearing the numeral 5 is depressed and therefore the bar 188 will rotate the printing wheel to bring the numeral 5 thereon into a printing position. In the machine according to the present construction the printing wheels are always actuated even when the printing mechanism is not adjusted to make impression and every time that the sliding block 50 is brought back to a zero position and locked by the lever 23 the printing wheels are rotated by the racks 188 back to a zero position.

The means for swinging the printing mechanism into and out of an impression position to transfer the adjustment of the printing mechanism to the tape or ribbon, hereinafter described, will now be described in detail.

The printing wheels, carried by the arm 193, are swung downwardly into an impression position at each time the main operating lever 84 is swung rearwardly. As shown a lever 178 is mounted upon the shaft 74 and is provided with an engaging portion 177. The lever 178 engages a pin 195 projecting inwardly from the arm 193 to transmit downward movement to the arm or lever 193 for the purpose of making an impression. A spring 196 engages the lower side of the pin 195 to normally hold the lever 193 in an upper position and to return the lever 193 from a downward to an upper position. A lever 175 is pivoted upon the main operating lever 84 at 173 and is provided with a handle 174 and a rear end 176 adapted for contact with the engaging portion 177. When the main operating lever 84 is swung rearwardly and the lever 175 is in the position shown in Fig. 1 the end 176 will engage the portion 177 and depress the rear end of the lever 178 against the pin 195 and thereby depress the printing mechanism from the position shown in Fig. 1 into an impression position. Fig. 5 shows a lever 175 in engagement with the portion 177. When it is desired to throw the printing mechanism out of operation the lever 175 is moved away from its stop pin, adjacent the pivot 173, so that the end 176 will not engage the portion 177 and this will permit the lever 84 to be swung rearwardly without depressing the printing mechanism.

An inking pad is mounted upon a support 207 and is held in engagement with the printing wheels 190 when the same are in the position shown in Fig. 5 and is withdrawn therefrom during downward movement of the printing wheels so as to permit of effecting an impression thereby. As shown the support 207 is provided with a sleeve 206 mounted upon a pivot pin 205. The pin 205 is mounted on an arm 199 which latter is pivotally mounted at 200 upon the frame of the machine. The arm 199 is normally held in the position shown in Fig. 1 by a spring 203 which bears with its free end upon a pin 204 located at one side of the pivot 200. The support 207 is held in fixed relation with respect to the arm 199 by a pin 208 which projects below an extension 209 of the support 207, as clearly shown in Fig. 4. It is obvious that the support 207 and the arm 199 swing as one piece about the pivot 200. However it will be understood that the arm 199 can swing freely backward or downward after the support 207 has reached or engaged an abutment. Movement of the arm 199 under action of spring 203 against pin 204 is limited in one direction by an abutment 202 (Figs. 2 and 8) mounted on the machine frame. In the construction shown the support 207 for the inking pad is moved out of engage-

ment and out of the path of the printing wheels by the arm 193. As shown in Figs. 2 and 4 the arm 193 is provided with a roller 197 bearing upon a recessed portion 5 198 of the arm 199. Owing to the inclination of the arm 199 and the fact that its pivot 200 is located in advance of and above the pivot 194 of the arm 193, the roller 197 will cause the arm 199 to move downwardly and rearwardly and will withdraw the inking pad rearwardly from beneath the printing wheels. Upon upward movement of the arm 193, the springs 203 will raise the arm 199.

15 I will next describe the means for advancing and holding the paper tape or ribbon upon which the impressions are made by the printing mechanism.

A roller 137 is mounted on the shaft 138 20 (Fig. 1) having bearings in a block 139. The block 139 is provided with ears 140 through which screws 141 extend into a plate 142. The plate 142 carries a printing block or pad 143 adapted to receive the impact of the printing wheels when the impression is made. A shaft 132 is mounted in the machine frame and extends transversely therethrough and is provided on the right hand side of the machine with disks 30 134 adapted for engagement with the roller 137 to hold the strip or paper therebetween. A knurled knob 135 is mounted upon one end of the shaft 132. On the left hand side of the machine (Fig. 3) the shaft 132 carries a ratchet wheel 133 adapted to be intermittently actuated by a pawl 131, (Figs. 9 and 10) mounted on the arm 75. In view of the fact that the arm 75 is rigidly mounted on the shaft 74 it moves to and fro with the main operating lever 84 and therefore every time the operating lever 84 is returned from its rearmost to its foremost position the wheel 133 is moved by the pawl 131 a distance equal to the length of one of the teeth of said wheel thereby advancing the paper strip on the pad 143 for the next impression.

The feet of the frame 1, of the machine, rest upon the base 136 on the left hand side 50 of the machine, but at the right hand side of the machine the frame is supported on the roller 137 by means of the disks 134 and there is a slight space between the feet at the right hand side of the machine and the base 136. The screws or bolts for connecting the feet of the frame 1 at the left hand side of the machine are preferably loosely fitted so as to permit of a relatively limited shifting of the right hand side of the machine. It will thus be seen that paper of any desired thickness may be passed between the disks 134 at the wheel 137 and that the weight of the machine is relied upon to insure a firm contact and engagement 65 of the disks 134 with the paper.

In printing a column of numbers upon a strip of paper it is not desirable and it is very confusing to have the zeros appear in advance of the first numeral, of the line of printing, reading to the right, and in order 70 to prevent the printing of zeros or ciphers, covering means is provided for covering a portion of the strip and the covering means is so arranged and constructed as to be adjustable automatically so that if the number 75 1 appears on the strip, see Fig. 12, the ciphers to the left of numeral 1 will be covered and will not be printed upon the strip. In the construction shown a covering plate 225 (Fig. 12) is provided and may consist 80 of a sheet of paper or other material which may be readily renewed, and the same is mounted upon a transversely sliding bar 224. The bar 224 is connected with one arm of a bell crank lever 223 which is pivoted 85 at 222 and has its other arm connected by links 221 with one extremity, 220, of a lever 216. The lever 216 is pivoted at 215 and is normally drawn toward the right hand side of the machine by spring 226 which is secured to said lever 216 and to the machine 90 frame. The lever 216 has an extension 214 adapted to be engaged by a shoulder 212 on a bar 213. The bar 213 is pivoted to an arm 211 which is rigidly mounted on the 95 shaft 74, on which the main operating lever 84 is mounted. By reference to Figs 12 and 13 it will be noted that the arm 211 and bar 213 can move some distance to the right before the shoulder 212 engages the extension 100 214. Now upon movement of the main operating lever 84 from a forward to a rearward position the shaft 74 is rotated in the direction of the arrow (Fig. 12) and the shoulder 212 is moved away from the extension 105 214. However upon the return movement of the main operating lever 84 to a forward position the shoulder 212 is moved against the extension 214 and acts through the end 220 and link 221, and also the bell crank lever 223 and bar 224, to 110 move the cover 225 inwardly or to the left of the machine. This will expose a greater portion of the paper strip to the action of the printing wheels. Now the movement of the main operating lever 84 is always uniform in either direction after it is once started because of the pawl arrangement 89 as shown in Fig. 9. It will therefore be obvious that reliance could not be placed on the movement of the operating lever 84 to effect the necessary and automatic adjustment of the cover 25 in printing lines where- 120 in a different number of figures or numerals are used. In one line the numeral 1 125 might appear and the cover 225 would have to be adjusted as shown in Fig. 12. In the next line the figure 100 might appear and then the cover 225 would have to be drawn inwardly two spaces. In the present ar- 130

rangement the parts are so proportioned that when the lever 84 is in its forward or normal position the shoulder 212 will engage the part 214 and throw the ends 217 into the position shown in Fig. 3, which is to the left of the extreme left hand lever 23. The end 217 of the end 216 bears upon the rod 218 and when the lever 84 is in the foremost position and all of the levers 23 are in a downward or locking position, the ends 219 of said levers 23, are at one side of or in front of the rod 218. Assuming that the operator desires to compose a number "125" on the key board, keys of corresponding denomination in the first three rows from the right of the machine will be depressed and this will release the first three levers 23 from their sliding blocks 50 and cause the projections 219 to assume a position immediately above the rod 218, as shown in Fig. 13, so as to intercept movement of the arm 216. When the lever 84 is swung rearwardly the shoulder 212 releases the engagement with the part 214 and allows the lever 216 to be swung by the spring 226 to the right of the machine until it is interrupted by the first of the three levers 23 which have been released. The lever 216 will then assume the position shown in Fig. 12 and cause the cover plate 225 to move to the right a sufficient distance to prevent all of the ciphers to the left of numeral 1 of the number "125", from being printed upon the strip.

The operation will doubtless be understood from the foregoing but may be briefly recapitulated to render sequential action of the various parts clear in relation which they bear to each other. Assuming that the key bearing the numeral "5" is depressed, as shown in Fig. 5, with the remaining parts in the position shown in Fig. 1, it will be seen that the bar 17 is moved rearwardly and that pin 20 has raised the lever 23 to release the hook 49 from the sliding block 50. The projection 219 is moved into the path of the bar 217 and the bar 24 has been moved upwardly to allow the pin 12 of the key 5 to take a position below the tooth 44 so as to lock the key 5. The lower end 6 of the key 5 is in the path of the sliding block 50 and will interrupt and arrest movement thereof in a rearward direction in the slot 45 when said block reaches the lower end of the key 5. The lever 84 is in the position shown in Fig. 1 and acting through the link 89 prevents the segment 52 from being swung rearwardly and in fact no further operation of the parts can take place until the lever 84 is swung rearwardly. Assuming now that the lever 84 is swung rearwardly, the roller 69 (Fig. 9) will ride up on the transfer cam surface 129 on to the

upper cam surface 70 and lift the segment 52 into mesh with its wheel 144 of the adding mechanism. The spring 60 maintains the pin 90 in the end of the slot 88 and carries the segment 52 rearwardly with the movement of the lever 84 until the sliding block 50 has reached the lower end of the pin 5. When the sliding block 50 has reached the end of the pin 5 and the pin stop the wheel 144 will have been rotated so as to bring the number "5" on the reading disk into an exposed position and the segment 52 will remain in a position of rest as will also the wheel 144 during the remaining rearward movement of the lever 84. In this description of operation it will be assumed that the adding mechanism and the printing mechanism are both used. Now during this rearward movement of the lever 84 the end 176 of the lever 175 will contact the engaging portion 177 and lower the arm 178 against the pin 195 to depress the printing wheels upon the block or pad 143. The roller 197 will act upon the arm 199 to withdraw the pad from beneath the printing wheels, as has been hereinbefore described and the impression of the numeral 5 will be made upon the paper strip. At the beginning of the rearward movement of the lever 84 the shoulder 212 (Fig. 12) will be withdrawn from the part 214 so that the lever 216 can be drawn by the springs 226 against the projection 219 of last lever 23 to the right of the machine by bringing the cover 225 to the right a sufficient distance to cover all of the ciphers in advance of the numeral "5," which will be in the unit position. The parts are so timed that the cover plate 225 will reach its position automatically prior to the depression of the printing wheels upon the pad 143. It will be understood that during the movement of the sliding block 50 from the position shown in Fig. 1 to the position shown in Fig. 5 the required movement will be transmitted to the rack 188, through bar 179, to adjust the unit printing wheel so that the numeral "5" will appear in a printing position prior to depression of the arm 193. The lever 84 will be moved rearwardly continuously until it has reached the extreme position to the rear so that the pawl 80 (Fig. 9) has been disengaged from the feet 82. It will be understood that the cam 72 will partake of the full movement of the lever 84 and at the rearward limit of its travel the roller 69 will reach the forward end of the cam surface 70, and, owing to the weight of the parts supported by the shaft 54 will descend so as to be in a position to be engaged by the transfer surface 128 and be guided thereby onto the surface 71. It will thus be seen that at the rearward limit of travel of the

lever 84, and before its forward return movement, the segment 52 will be lowered out of mesh with the adding mechanism. It will also be understood that the latch hook 91 has been carried rearwardly by the arm 87 and is riding loosely upon the pin 93. Now upon the return movement of the lever 84 to a forward position, the lever 175 will begin to release the printing mechanism so that it can be returned to its uppermost position on the action of spring 196. When the shoulder 92 of the hook 91 reaches the pin 93 it will draw the rack 95 forwardly against the action of spring 121 (Fig. 9). It will be understood that in printing the numeral 5 in the unit row there will be no occasion for the operation of the ten advancing mechanism therefore the end 160 (Fig. 11) will not be in the path of the actuating surface 170 and the cam 169 will be rotated idly in the direction of the arrow (Fig. 11) during forward movement of the rack 95. When the rack 95 has been moved forwardly approximately to the position shown in Fig. 8 the pin 93^a will engage the rear end of the hook 91 and cause the same to be released from the pin 93. It will be understood that the forward movement of the rack 95 and arm 94 will cause the arm 119 (Fig. 9) to descend so as to operate the lever 122 and at the forward end of this lever will idly actuate the part 40 and pass above the same. Now upon the return movement of the rack 95 under action of spring 121 the forward end of the lever 122 will engage the part 40 and acting through the part 38, rotate the shaft 36 so as to depress the releasing key 29 through arm 35. This will automatically release the depressed key 5 and permit the same to be returned to its upper or normal position under the action of its spring. During this return movement of the lever 84 the shoulder 212 will act to return the end of the lever 217 to the position shown in Fig. 3 and draw the part 225 to the left. Furthermore, and approximately at the time when the arm 94 is released, the end of a slotted link 89 will engage the pin 90 and the segment 52 will be drawn forwardly with the lever 84. This will act through the link 51 to move the sliding block 50 in the slot 45 to its foremost position so that it will ride under the end 49 of the lever 23, which has been freed by the return of the depressed key, and the end 49 will lock the sliding block 50 in a forward position as shown in Fig. 1. It will also be understood that during the forward movement of the block 50 the link 179 will actuate the rack 188 so as to return the printing wheel to a zero position. Now all of the parts are in a normal or starting position except the adding mechanism and it will be understood that the units wheel of the adding mechanism is in a position to expose the numeral 5. In order to return the units wheel in the adding mechanism to a zero or cipher position the lever 104 is swung forwardly to throw the wheels 113 into mesh with the wheels 144 and the cam portions 101 and 108 act through the link 97 to draw the arm 94 and rack 95 forwardly. It will be understood, as hereinbefore described, that this forward movement of the rack 95 is merely to insure the return of the member 161 to a non-acting position. Now it will be understood that the crank 115 may be turned in either direction to return the adding mechanism to a zero position. If the crank should be turned in such a direction as to cause the pin 148 to engage the arm 154 then the member 161 would be set into position for engagement with the cam 169. It will thus be seen that it is very important to always actuate the rack 95 forwardly and rearwardly after the completion of each adding operation so as to positively insure movement of the trip 161 into a non-acting position with respect to cam 169. Now after the adding mechanism is returned to a zero position and the lever 104 has been returned to the position shown in Fig. 1 the cam 101 will release the cam portion 100 and allow the springs 121 to return the arm 94 to the position shown in Fig. 2 thereby reversing rotation of the cam 169 and positively insuring the return or the retention of the part 161 in the full line position shown in Fig. 11 at the completion of the return of the adding mechanism to zero. By reason of the fact that all of the keys are depressed and that no action of the parts can take place until the lever 84 is moved rearwardly the operator will have time to observe whether or not he has depressed the proper key before operating the lever 84. If an improper key has been depressed, the releasing key 29 of such row can be depressed so as to release said key and permit of correction. If a number of incorrect keys have been depressed it is merely necessary to lower the pin 37 so as to actuate the shaft 36 whereupon all of the arms 35 will act upon all of the releasing keys 29 and depress the same and this will release all of the depressed keys upon the key board. It will thus be seen that through the lever 122 all of the depressed keys on the key board are automatically released so as to be returned to a normal position at the end of the adding operation, or printing operation, and that independently of this lever 122 a depressed key or any one row of the depressed keys or all the rows can be released by operating the pin 37. A further advantage resides in the fact that when the

key 126 (Fig. 10) is depressed the parts 38 and 40 are thrown out of the path of the lever 122 so that the latter cannot act upon them at all. This adjustment it will be remembered is made when it is desired to print and not to add. By this arrangement the keys are released at the end of each printing operation by depressing the individual releasing keys 29 and the keys on the key board are not automatically released at the end of each printing operation. This arrangement enables the operator to retain certain numerals in the printing operation without again depressing the keys as the keys will remain depressed until the operator has depressed the individual releasing key 29 of such row.

I claim:—

1. In an adding machine, the combination with adding mechanism including a toothed wheel, a sliding block, an oscillating rack segment connected with said block and adapted to mesh with but normally out of alignment with said wheel, a locking device for said sliding device, a plurality of keys each arranged to be depressed into the path of and arrest said block, connections between said keys and locking device for releasing the latter to free said blocks when a key is depressed, a spring for actuating said segment, an operating lever connected with said segment to control movement thereof, means for moving said segment into mesh with said wheel and subsequently out of mesh with said wheel, and means for releasing said depressed keys.

2. In an adding machine, the combination with adding mechanism including a toothed wheel, a sliding block, an oscillating rack segment connected with said block and adapted to mesh with but normally out of mesh with said wheel, a locking device for said sliding blocks, a plurality of keys each arranged to be depressed into the path of and arrest said block, connections between said keys and locking device for releasing the latter to free said block when a key is depressed, a spring for actuating said segment, an operating lever connected with said segment to control movement thereof, and means for moving said segment into mesh with said wheel upon initial movement of said lever and subsequently moving said segment out of mesh with said wheels.

3. In an adding machine, the combination with adding mechanism including a toothed wheel, a sliding block, an oscillating rack segment connected with said block and adapted to mesh with but normally out of mesh with said wheels, a locking device for said block, a plurality of keys each arranged to be depressed into the path of and arrest movement of said block, connections between said keys and locking device for releasing the latter to free said block when

a key is depressed, a spring for actuating said segment, an operating lever connected with said segment to control movement thereof until said block is released by such depressed key, means for moving said segment into mesh with said wheel at the beginning of movement of said levers and moving said segment out of mesh with said wheel at the end of movement of said levers.

4. In an adding machine, the combination with adding mechanism including a toothed wheel, a sliding block, an oscillating rack segment connected with said block and adapted to mesh with but normally out of mesh with said wheel, a locking device for said sliding block, a plurality of keys each arranged to be depressed into the path of and arrest movement of said block, connections between said keys and locking device for releasing the latter to free said block when the key is depressed, a spring for actuating said segment, an operating lever connected with said segment to control movement thereof, means for moving said segment into mesh with said wheel and subsequently moving the same out of mesh with said wheel, and automatic means for releasing said keys.

5. In an adding machine, the combination with adding mechanism including a toothed wheel, a sliding block, an oscillatory rack segment connected with said block and adapted to mesh with but normally out of mesh with said wheel, a locking device for said sliding block, a plurality of keys arranged to be depressed into the path of said block, connections between said keys and locking device for releasing the latter to free said block when it is depressed, a spring for actuating said segment, an operating lever connected with said segment to control movement thereof, a cam connected with and movable with said lever, and means cooperating with said cam and connected with said segments for moving the latter into and out of mesh with said wheel.

6. In an adding machine, the combination with adding mechanism, including a toothed wheel, a sliding block, an oscillating rack segment connected with said sliding block adapted to mesh with but normally out of mesh with said wheel, a plurality of keys arranged to be depressed into the path of said block, a spring for actuating said segment, an operating lever connected with said segment to control movement thereof, a cam connected with and movable with said lever, and means cooperating with said cam and connected with said segment for moving the same into and out of mesh with said wheel.

7. In an adding machine, the combination with adding mechanism including a toothed wheel, a sliding block, an oscillating rack segment connected with said sliding block adapted to mesh with but normally out of

mesh with said wheel, a plurality of keys each arranged to be depressed into the path of and arrest movement of said block, a spring for actuating said segment, an operating lever connected with said segment to control movement thereof, and means for moving said segment into mesh with said wheel and subsequently moving the same out of mesh with said wheel.

8. In an adding machine, the combination with adding mechanism including a toothed wheel, a sliding block, an oscillating rack segment connected with said block and adapted to mesh with but normally out of mesh with said wheel, a plurality of keys each arranged to be depressed into the path of and arrest movement of said block, a spring for actuating said segment, an operating lever arranged to swing forwardly and backwardly and connected with said segment to control movement thereof, and means for moving said segment into mesh with said wheel during the rearward movement of said lever and moving said segment out of mesh with said wheel during forward movement of said lever.

9. In an adding machine, the combination with adding mechanism including a toothed wheel, a sliding block, an oscillating rack segment connected with said block and adapted to mesh with but normally out of mesh with said wheel, a plurality of keys each arranged to be depressed into the path of said block to arrest movement of the same, a spring for operating said segment, an operating lever arranged to move forwardly and backwardly and connected with said segment to control movement thereof, and means actuated by said lever for moving said segment into mesh with said wheel during rearward movement of said lever and out of mesh with said wheel during forward movement of said lever.

10. In an adding machine, the combination with an adding mechanism, an oscillating member for actuating said mechanism, an operating lever connected with said member, a ten advancing device for said mechanism, an oscillating element for actuating said device, and means operatively connecting said element with said lever.

11. In an adding machine, the combination with an adding mechanism, an oscillating member for actuating said mechanism, an operating lever connected with said member, a ten advancing device for said mechanism, an oscillating element for actuating said device, and means operatively connecting and disconnecting said element with and from said lever.

12. In an adding machine, the combination with an adding mechanism, including a toothed wheel, an oscillating rack segment for actuating said wheel, an operating lever connected with said segment and arranged

to move to and fro, a ten advancing device for said mechanism, an oscillating element for actuating said device, means operatively connecting said element with said lever during one movement, and disconnecting said element during movement of said lever in such direction, and a spring for moving said element in an opposite direction.

13. In an adding machine, the combination with an adding mechanism, a rack for actuating said mechanism, an operating lever for controlling movement of said rack, a ten advancing device for said mechanism, a trip device, means included in said adding mechanism for throwing said trip device into an operative position, and means acting through said trip device for operating said ten advancing device and subsequently throwing said trip device out of an operating position.

14. In an adding machine, the combination with an adding mechanism, a rack for actuating said mechanism, an operating lever connected with said rack, a ten advancing device for said mechanism, a trip device, means included in said adding mechanism for throwing said trip device into an operative position, and means operated by said lever and acting through said trip device for operating said ten advancing device.

15. In an adding machine, the combination with an adding mechanism, a rack for actuating said mechanism, an operating lever connected with said rack, a ten advancing device for said mechanism, a trip device, means included in said mechanism for setting said trip device, a cam acting upon said trip device for operating said ten advancing device and for throwing said trip device out of an operative position, and means operated by said lever for actuating said cam.

16. In an adding machine, the combination with an adding mechanism, an oscillating rack for actuating said mechanism, an operating lever connected with said rack, a ten advancing device for said mechanism, a trip device for said advancing device, means included in said mechanism for setting said trip device, a cam acting through said trip device for operating said ten advancing mechanism and for throwing said trip device out of an operative position, an oscillating member for said cam, means operatively connecting said oscillating member with said lever to operate said cam in one direction, and a spring connected with said member to operate said cam in a direction opposite to said first mentioned direction.

17. In an adding machine, the combination with adding mechanism, a rack for operating said adding mechanism, a ten advancing device for said mechanism, a trip device for said advancing device, means in-

cluded in said mechanism for setting said trip device, a cam acting through said trip device for operating said advancing device and serving to throw said trip device out of an operative position, a spring controlled oscillating element for operating said cam, an operating lever, means connecting said oscillating element with said lever to operate said ten advancing device during an adding operation, means for returning said adding mechanism to zero position after the completion of an adding operation, and mechanism connecting said means with said oscillating element to finally throw said trip device out of an operative position.

18. In an adding machine, the combination with adding mechanism, a rack for operating said mechanism, a ten advancing device for said mechanism, a trip device for said advancing device, means included in said mechanism for setting said trip device, oppositely rotating means acting through said trip device to operate said advancing device and serving to throw said trip device out of an operative position, an operating lever adapted for connection with said oppositely rotating means to operate the same during an adding operation, means for returning said adding mechanism to a rearward position at the completion of an adding operation, and mechanism connecting said means with said oppositely rotating means for finally throwing said trip out of an operative position after the adding operation has been completed.

19. In an adding machine, the combination with adding mechanism, a rack for operating said adding mechanism, a ten advancing device for said mechanism, a trip device for said advancing device, means included in said mechanism for setting said trip device, a cam acting through said trip device to operate said advancing device and serving to throw said trip device out of an operative position, a spring controlled oscillating element for oscillating said cam in opposite directions, an operating lever, means connecting said oscillating element with said lever to operate said advancing device during an adding operation, means for returning said adding mechanism to zero position after completion of an adding operation, and links connecting said means with said element for operating the same to finally throw said trip device out of operative position after the completion of an adding operation.

20. In an adding machine, the combination with adding mechanism, a rack for operating said mechanism and normally out of driving relation therewith, a lever for operating said rack, a cam operating with said lever and provided with throw-in and throw-out cam surfaces, and transfer surfaces connecting said throw-in and throw-

out surfaces, a roller riding on said cam surfaces, means operated by said roller for moving said rack into and out of driving connection with said adding mechanism, and means for maintaining said roller out of engagement with said surfaces, substantially as and for the purposes set forth.

21. In an adding machine, the combination with adding mechanism, a rack for operating said mechanism normally out of driving relation therewith, a lever for operating said rack, a cam operating with said lever and provided with throw-in and throw-out cam surfaces, and transfer cam surfaces connecting said throw-in and throw-out surfaces, a roller riding on said surfaces, and means operated by said roller for moving said rack into and out of driving connection with the adding mechanism substantially as and for the purpose set forth.

22. In an adding machine, the combination with a plurality of main keys, an adding mechanism, a main operating lever for operating said adding mechanism, mechanism for locking said keys in depressed position, and mechanism for releasing depressed keys, a releasing key for operating said mechanism, means for operating said releasing key, a device actuated from said lever for operating said means to release depressed keys on the return stroke of said lever, and a device for throwing said adding mechanism out of operation and serving to throw said means out of the path of said device actuated from said lever for operating said means.

23. In an adding machine, the combination with a plurality of main keys, an adding mechanism, an operating lever for operating said adding mechanism, mechanism for locking said keys in depressed position, and mechanism for releasing depressed keys, a manually operable key for operating said mechanism, means for automatically operating said releasing key, a lever actuated by said main operating lever for operating said means, and a throw-out lever for said adding mechanism arranged to move said means out of operative relation with said first mentioned levers.

24. In an adding machine, the combination with a plurality of main keys, an adding mechanism, a main operating lever for said machine, mechanism for locking said keys in depressed position, and mechanism for releasing depressed keys, a manually operable releasing key for operating said mechanism, a device for operating said releasing key, a member actuated by said main lever for operating said device and means for throwing said adding mechanism out of operative relation and also serving to throw said device out of relation with said member.

25. In an adding machine, the combina-

5
10
15
20
25
30
35
40
45
50
55
60
65

70
75
80
85
90
95
100
105
110
115
120
125
130

tion with a sliding block, a plurality of keys arranged to be depressed into the path of said block to arrest movement thereof, a movable frame, a printing device carried by said frame, a pad arranged to receive the impact of said device, means connected with said block for operating said printing device, a main operating lever for said machine, and a member actuated from said lever for moving said device into a printing position.

26. In an adding machine, the combination with a sliding block, a plurality of keys arranged to be depressed into the path of said block to arrest movement thereof, a pivotally mounted frame, a printing device including a printing wheel and a toothed wheel carried by said frame, a pad arranged to receive the impact of said printing wheel, links connected with said block and including a rack engaging said toothed wheel for operating the same, a main operating lever for said machine, a member actuated from said lever for moving said wheel into a sitting position.

27. In an adding machine, the combination with a sliding block, a plurality of keys arranged to be depressed into the path of said block to arrest movement thereof, a pivotally mounted frame provided with a printing device including a printing wheel and a pinion therefor, a pad arranged to receive the impact of said device, an inking pad for said wheel, links connected with said block and including a rack meshing with said pinion for operating said wheel, a main operating lever provided with means for moving said printing wheel into a printing position, and means supporting said inking pad and actuated by said pivoted frame for withdrawing said inking pad from engagement with said wheel during printing operation.

28. In an adding machine, the combination with a sliding block, a plurality of keys arranged to be depressed into the path of said block to arrest movement thereof, a pivotally mounted frame, a printing device carried by said frame, a lever for moving said frame to bring said printing device into a printing position, means connected with said block for operating said printing device, a main operating lever, and a member carried by said main operating lever for operating said first mentioned lever to move said printing device into a printing position.

29. In an adding machine, the combination with a sliding block, a plurality of keys arranged to be depressed into the path of said block to arrest movement thereof, a pivotally mounted frame, a printing device carried by said frame, a main operating shaft, a lever arm mounted on said main operating shaft for depressing said frame to bring said

device into a printing position, a main operating lever mounted on said shaft, and a member carried by said main operating lever for engaging said lever arms to depress said frame into a printing position.

30. In an adding machine, the combination with a sliding block, a plurality of keys arranged to be depressed into the path of said block to arrest movement thereof, a movable frame, a printing device carried by said frame, means connected with said block for operating said printing device, a main operating lever, and means carried by said main operating lever for operating said frame to move the same into a printing position, said means being arranged for adjustment out of relation with said frame.

31. In an adding and printing machine, the combination with an adding mechanism, a sliding block, a plurality of keys arranged to be depressed into the path of said block, a member connected with said block for actuating said adding mechanism, a printing device, means connected with said sliding block for adjusting said printing device, and a main operating lever for controlling movement of said member and actuating said printing device.

32. In an adding and printing machine, the combination with an adding mechanism, a sliding block, a plurality of keys arranged to be depressed into the path of said block, a member connected with said block for actuating said adding mechanism, a printing device, means connected with said sliding block for adjusting said device, a main operating lever for controlling movement of said member and actuating said printing device, and means for rendering said adding mechanism operative.

33. In an adding and printing machine, the combination with an adding mechanism, a sliding block, a plurality of keys arranged to be depressed into the path of said block, a member connected with said block for actuating said adding mechanism, a printing device, means connected with said sliding block for adjusting said device, a main operating lever for controlling movement of said member and actuating said printing device, and means for rendering said printing device inoperative.

34. In an adding and printing machine, the combination with an adding mechanism, a sliding block, a plurality of main keys arranged to be depressed into the path of said block, a manually operable releasing key for releasing said depressed keys, means for releasing said manually operable key, a printing device, a member connected with said block for operating said adding mechanism, means connected with said block for adjusting said printing device, a main operating lever for controlling movement of said member and actuating said printing device, and

an element operated from said lever for operating said releasing key at the completion of each adding operation.

35. In an adding and printing machine, the combination with an adding mechanism, a sliding block, a plurality of main keys arranged to be depressed into the path of said block, a manually operable releasing key for releasing depressed main keys, means for releasing said manually operable key, a printing device, a member connected with said block for operating said adding mechanism, means connected with said block for adjusting said printing device, a main operating lever for controlling movement of said member and actuating said printing device, an element operated from said lever for operating said releasing key at the completion of each adding operation, and a device for rendering said adding mechanism inoperative and moving said releasing means out of operative relation from said elements.

36. In an adding and printing machine, the combination with a printing device, an adding mechanism, and means for preventing the printing of certain characters of said device, of a main operating lever coöperatively connected with said device and said mechanism and with said means for actuating the same.

37. In an adding and printing machine, the combination of a printing device, an adding machine, spring actuated means for preventing the printing of certain of the characters of said device, and a main operating lever coöperatively connected with said device and with said mechanism and said means for actuating the same.

38. In an adding machine, the combination of a printing device therefor, means operating the weft to be printed step by step, an adjustable cover interposed between the weft and said device for printing certain characters of said device on said weft, and a main operating lever coöperatively connected with said device and with said means and with said cover for actuating the same.

39. In an adding and printing machine, the combination with an adding mechanism, a printing device, a plurality of keys, sliding blocks controlled by said keys and opera-

tively connected with said device and mechanism, locking devices for said blocks controlled by said keys, a cover plate for preventing the printing of certain characters of said device, and spring actuated means controlled by said locking devices for effecting adjustment of said plate.

40. In an adding and printing machine, the combination with an adding mechanism, a printing device, a plurality of keys, sliding blocks controlled by said keys and operatively connected with said device and mechanism, a main operating lever, locking devices for said blocks controlled by said keys, a cover plate for preventing the printing of certain characters of said device, and spring actuated means operated by said lever and controlled by said locking devices for effecting adjustment of said plate.

41. In an adding and printing machine, the combination with an adding mechanism and a printing device, a main operating lever for operating said mechanism and device, a machine frame supporting said mechanism, device and lever, a base for said frame, said frame being loosely connected with said base at one side, a web roller on said base, a web roller on said frame engaging said base roller and arranged to support one side of the frame and receive between said rollers webs of different thickness, and means operated from said lever for imparting a step by step movement of the webs between said rollers.

42. In an adding machine, the combination of a plurality of rows of depressible main keys, locking means for locking said keys in their depressed position, a releasing key for each row of the main keys for disengaging the depressed keys from said locking means, means for depressing all of the releasing keys simultaneously, and a main operating lever coöperatively connected with the main keys, and locking means for actuating the same and for releasing the keys.

In testimony whereof, I have hereunto set my hand in presence of two witnesses.

ADOLF BORDT,

Witnesses:

S. H. SHANK,
N. R. SHANK.