

No. 656,872.

Patented Aug. 28, 1900.

G. R. & W. C. WILLIAMS.

AUTOMATIC MECHANISM FOR FEEDING SHEETS OF PAPER.

(Application filed Jan. 5, 1900.)

(No Model.)

3 Sheets—Sheet 1.

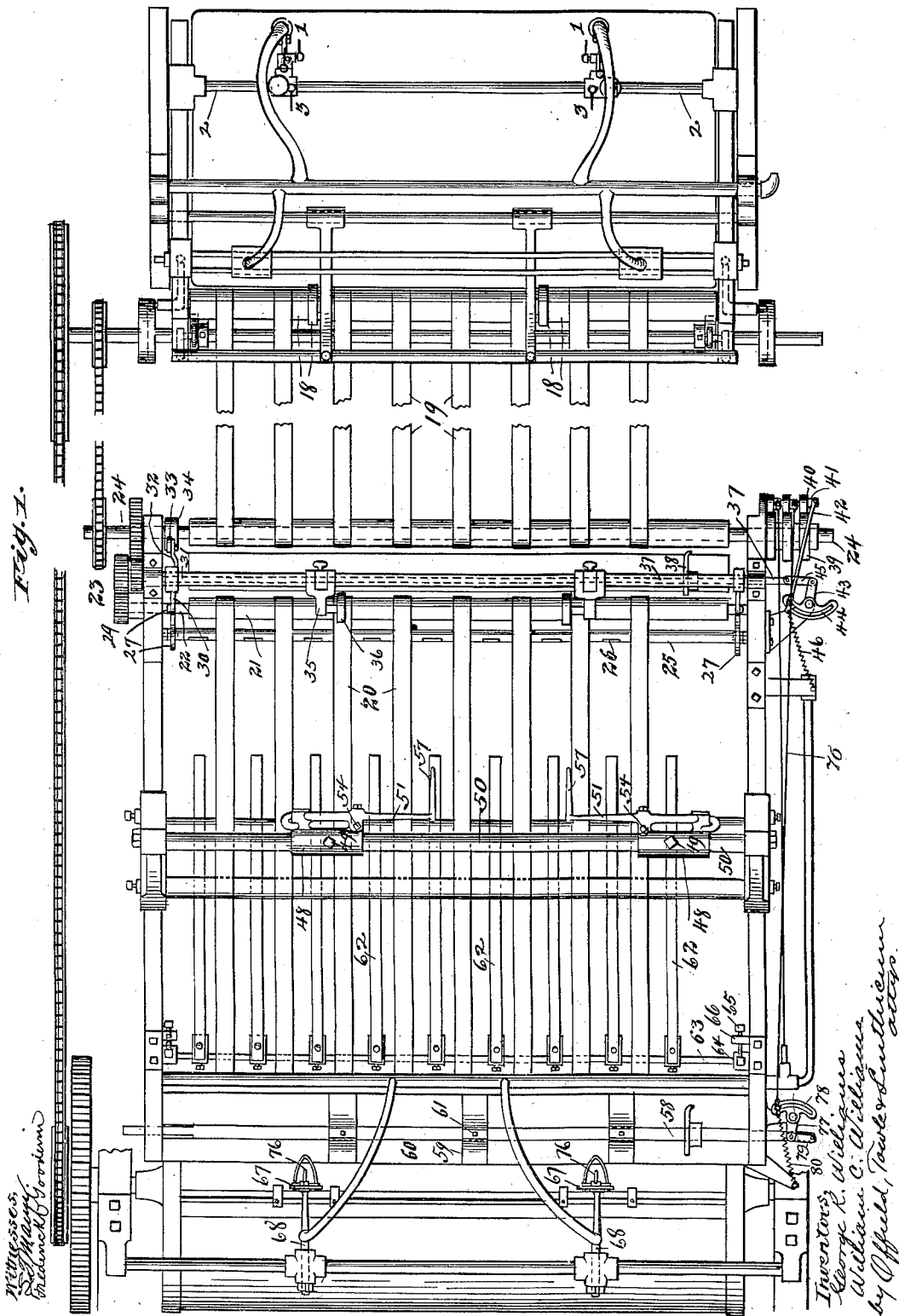

No. 656,872.

Patented Aug. 28, 1900.

G. R. & W. C. WILLIAMS.

AUTOMATIC MECHANISM FOR FEEDING SHEETS OF PAPER.

(Application filed Jan. 5, 1900.)

(No Model.)

3 Sheets—Sheet 2.

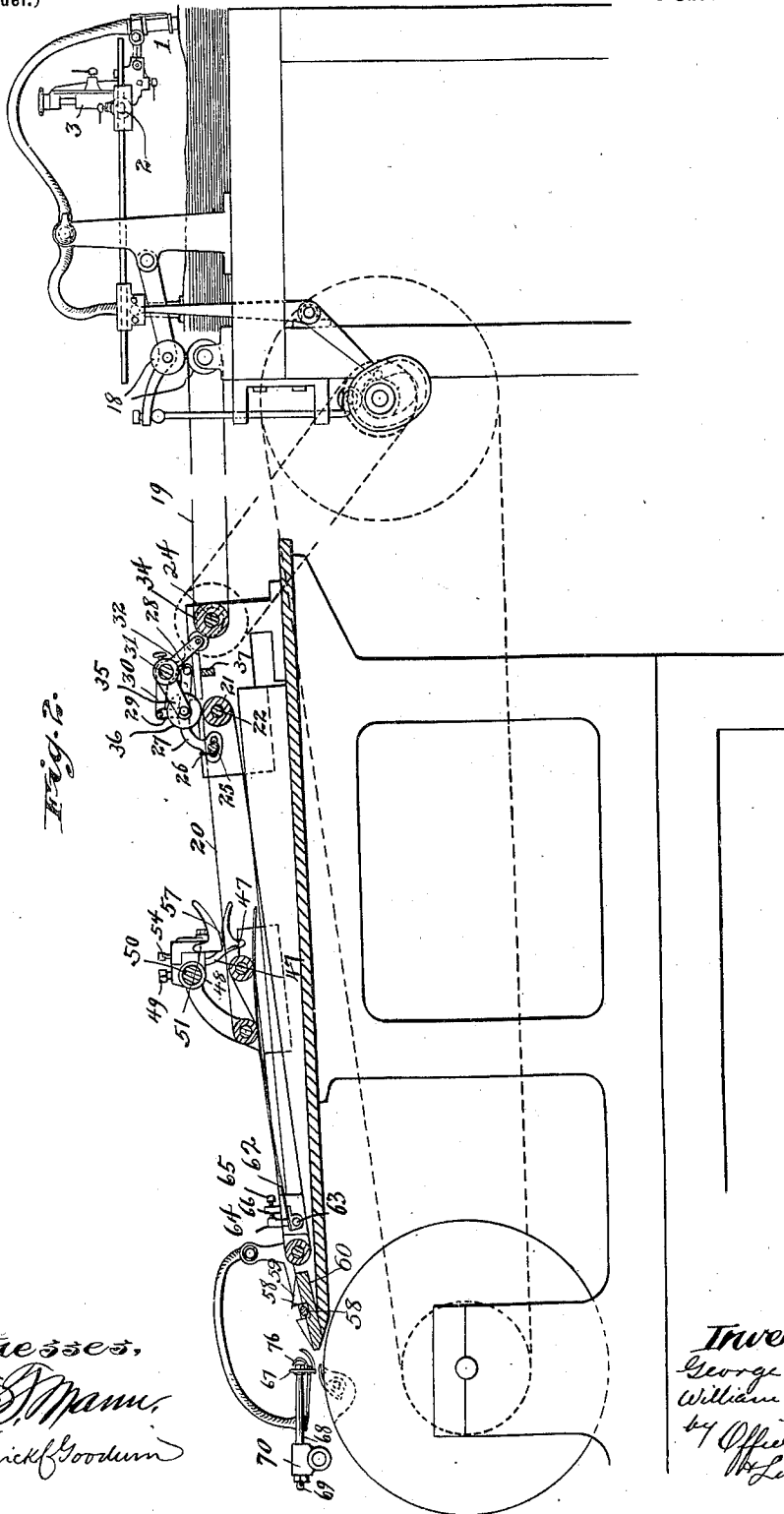

Fig. 2.

Witnesses,
F. Munn
Frederick Goodrum

Inventors,
George R. Williams
William C. Williams
by *Offield, Towle*
W. Luthierum,
attys.

No. 656.872.

Patented Aug. 28, 1900.

G. R. & W. C. WILLIAMS.

AUTOMATIC MECHANISM FOR FEEDING SHEETS OF PAPER.

(Application filed Jan. 5, 1900.)

(No Model.)

3 Sheets—Sheet 3.

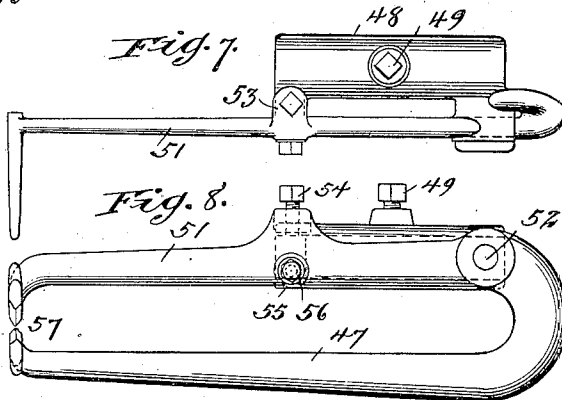
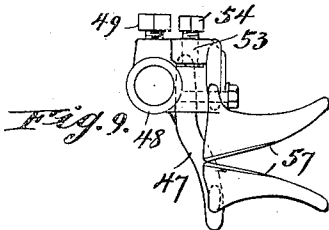
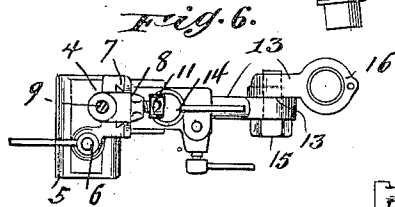
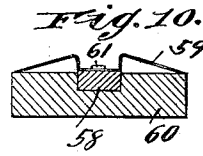
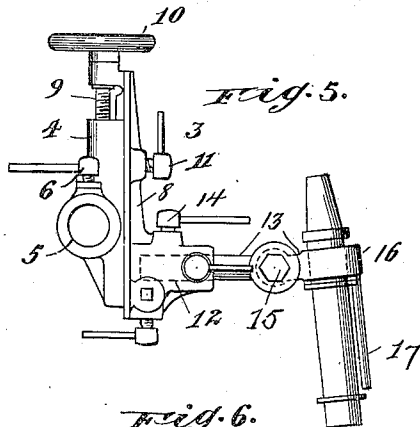
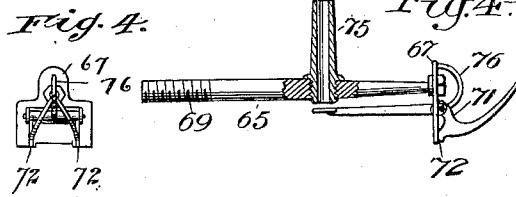
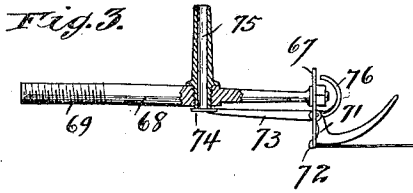

Witnesses,
J. S. Mann,
Fredrick Goodrum

Inventors
George R. Williams,
William C. Williams,
Toy Office, Towle & Linticum,
Attys.

UNITED STATES PATENT OFFICE.

GEORGE R. WILLIAMS AND WILLIAM C. WILLIAMS, OF NEW YORK, N. Y.,
ASSIGNORS, BY MESNE ASSIGNMENTS, TO B. V. BECKER.

AUTOMATIC MECHANISM FOR FEEDING SHEETS OF PAPER.

SPECIFICATION forming part of Letters Patent No. 656,872, dated August 28, 1900.

Application filed January 5, 1900. Serial No. 464. (No model.)

To all whom it may concern:

Be it known that we, GEORGE R. WILLIAMS and WILLIAM C. WILLIAMS, of New York, (Brooklyn,) in the county of Kings and State
5 of New York, have invented a certain new and useful Improvement in Automatic Mechanism for Feeding Sheets of Paper, of which the following is a specification.

This invention relates to automatic mechanism for feeding sheets of paper, being more particularly adapted for use in feeding such sheets one at a time from a pile to a printing-press, folding-machine, or other similar apparatus.

15 The chief object of our invention is to accomplish such feeding with great accuracy and to reduce the delays usual in the operation of such machinery to a minimum.

To these ends our invention consists in certain novel features which we will now proceed to describe, and will then particularly point out in the claims.

In the accompanying drawings, Figure 1 is a plan view of a structure embodying our invention. Fig. 2 is a view of the same, partly in elevation and partly in section. Figs. 3 and 4 are respectively side and front elevations of the combined front guide and stop. Fig. 4^a is a view similar to Fig. 3, showing
30 the parts in their normal position. Fig. 5 is a side elevation, and Fig. 6 a plan view, of the suction-cup bracket; and Figs. 7, 8, and 9 are respectively plan, front, and side elevations of the sheet-gaging devices.

35 The class of machines to which our present invention relates is a well-known one in which suction-cups are employed to pick up in succession the top sheets of a pile of paper and transfer them one by one by means of
40 feed-rollers and feed-tapes to a printing-press or folding-machine. The general structure of these machines is so well known as to require no particular description, and we will therefore describe only those particular portions of the machine to which our invention
45 relates.

In the said drawings the rear suction-cups are indicated at 1 and the carriage with which they are connected at 2, this connection being effected by means of a bracket 3, which

is shown in detail in Figs. 5 and 6 of the drawings. These brackets are in duplicate, and we will therefore describe the construction of a single one, the same description being applicable to both. Each bracket consists of a
55 base 4, having a sleeve 5, by means of which it may be adjustably connected with the carriage 2, being secured after adjustment by means of a set-screw 6. This base is provided with vertical ways 7, in which is mounted to
60 slide vertically the bracket proper, 8, which may be adjusted in said ways by means of a feed-screw 9, provided with a hand-wheel 10, and which may be securely locked after adjustment by means of a set-screw 11. This
65 bracket proper, 8, is provided with a horizontal socket 12 to receive one end of an arm 13, which may be longitudinally and axially adjusted in said socket and which may be secured after adjustment by means of a set-
70 screw 14. The arm 13 is provided intermediate its ends with a joint and a horizontal clamping-screw 15, by means of which the angle of the outer portion of the arm to the
75 horizontal may be adjusted as desired, and said outer portion is provided with a sleeve or collar 16 to receive the suction-cup 17. It will be seen that the suction-cup may be adjusted vertically, horizontally, and axially
80 around two axes at right angles to each other, so that its position may be varied as desired or as the circumstances require.

The individual sheets are fed from the suction-cups to the carrying-tapes by means of
85 feed-rollers 18. In mechanisms of this class as ordinarily constructed the feeding-tapes are continuous or in a single series between the feed-rollers 18 and the press or folding-machine. In our improved construction we
90 divide these transfer-tapes into two sets or series, of which that set or series adjacent to the lifting mechanism has a comparatively high speed in order to remove the sheets from above the pile before the suction-cups
95 are lowered to lift the next sheet. The second series has a slower speed, being equal to that of the press or folding-machine, so as to deliver the sheets into the machine at the same rate at which the machine runs. By
100 this means the delivery of the sheet from the

pile by shoving it over tapes which move at a lower rate of speed than the advance of the sheet is avoided. The first section or series of these tapes is indicated at 19, and its speed is equal to that of the feed or delivery rollers 18 of the sheet-lifting mechanism. The second or slower section or series of tapes is indicated at 20, these tapes being driven from feed-rollers 21 on a shaft 22, connected by suitable speed-reducing gearing 23 with the shaft 24, which drives the tapes 19. It will be seen that the sheets as they come from the delivery-rollers 18 are delivered upon the tapes 19, which travel at the same rate of speed as the sheet being delivered, so that the difficulties just referred to as attendant upon the old mode of delivery of the sheet upon tapes moving more slowly than itself are avoided.

We have also provided stop mechanism for arresting the movement of the sheet before its delivery from the first section of the carrying-tapes to the second section and means whereby the sheet may be shifted laterally while its motion is thus arrested to one side or the other of the apparatus, as may be desired, so that it may be delivered to the press or folding-machine in proper position for printing or folding without involving the shifting of the position of the pile of sheets upon their supporting-table when it is desired to shift laterally the line of delivery of the sheets. To accomplish these ends, we employ a stop-bar 25, having upwardly-extending stop-fingers 26, which may be projected above the level of the tapes 20 at a point in front of the feed-rollers 22. This stop-bar is suitably actuated by means of arms 27, pivoted at 28 to the side frames of the apparatus and connected by a link 29 with an arm 30 on a transverse rock-shaft 31. This rock-shaft 31 is actuated by means of an arm 32, provided with a roller 33, which bears upon a cam 34 on the shaft 24. This rock-shaft 31 is also provided with arms 35, carrying feed-rollers 36, which are adapted to be pressed against the tapes 20 and rollers 21 at suitable intervals to cause the forward feed of the sheets.

Between the two sets of tapes is located the shifting-bar 37, which is provided with the usual side edge guide 38, which may be transposed thereon from one side of the apparatus to the other. This shifting-bar is provided with means for engaging and carrying with it the sheet at proper intervals. In the present instance the guide 38 serves this purpose by bearing against the edge of the sheet. This shifting-bar is operated from the shaft 24 by means of a cam 39 thereon, which acts upon a roller 40 on the upper end of a pivoted arm 41. This arm 41 is connected, by means of a rod 42, with a lever 43, having a transverse slotted arm 44, by means of which the connection of the rod 42 with said lever may be adjusted from one side of its pivot to the

other. The other or radial arm of the lever 43 is connected by a link 45 with the shifting-bar 37. A spring 46 serves to hold the roller 40 against the cam 39. It will be seen that by the operation of the mechanism described the shifting-bar will at intervals be moved laterally, carrying along with it the sheet, and returning to its original position after the sheet has been fed forward. It will also be seen that by transferring the guide 38 to the other end of the bar and reversing its position thereon and at the same time transferring the connection of the rod 42 from one end of the slotted arm 44 to the other the movement of the shifting-bar will be reversed and the sheet will be laterally shifted to the opposite side. This change may be readily and quickly made and dispenses with the necessity of shifting the entire pile of sheets from one side of the table to the other, the pile remaining central and the shifting being rapidly and effectually accomplished by the mechanism described. While the sheets are being carried along by the second set or series of carrying-tapes they pass between the jaws of calipers so adjusted as to permit the passage of a single sheet only between them. One of these calipers is shown in detail in Figs. 7, 8, and 9 of the drawings. It consists of a fixed arm 47, having a sleeve 48 and set-screw 49, by means of which it is secured to a cross-bar 50. In conjunction with this fixed arm, which is the lower arm of the calipers, we employ a movable arm 51, hinged to the fixed arm at 52 and provided with a lug or extension 53, which bears upon the fixed arm without screwing into the same. The movable arm 51 is also provided with a downwardly-extending open-mouthed slot 55, through which passes a clamping-bolt 56, taking into the fixed arm. The calipers are provided with jaws 57, of any approved construction, at the free ends of the arms. It will be seen that the distance between the fixed and movable arms may be readily and accurately adjusted by means of the screw 54, which may be provided with a micrometer-scale to determine the adjustment. It will also be seen that in case of the clogging of paper in the calipers the movable arms of these latter may be readily raised by loosening the clamping-bolts 56, whereupon the paper may be removed and the movable arms immediately returned to their adjusted position, which is determined by the contact of the screws 54 with the fixed arms. Heretofore these jaws have been adjusted by means of an adjusting-screw which takes into the fixed arm, so that when it is desired to disengage a sheet the adjustment is disturbed in the act of separating the arms for this purpose and must be again obtained before the machine can operate. With our improved construction the arms always return to their adjusted position as soon as dropped, in which position they may be readily secured by the

clamping-bolts 56, and owing to the fact that the slots 55 are open-mouthed the bolts do not need to be withdrawn, but are simply loosened to permit the raising of the arms.

5 At the discharge end of the mechanism is located a second shifting-bar 58, which is operated in the same manner as the shifting-bar 37 and by a substantially-identical mechanism. The rod 42 is connected, by means of
 10 a wire or the like 76, with a lever 77, having a transverse slotted arm 78, by means of which the connection of the rod 42 with said lever may be adjusted from one side of its pivot to the other. The other or radial arm
 15 of the lever 77 is connected by a link 79 with the shifting-bar 58. A spring 80 serves to maintain a tension upon the parts. These parts operate, as in the case of the mechanism operating the shifting-bar 37, to move
 20 the said bar laterally at intervals to shift the sheet and also permit the reversal of the movement of the shifting-bar, so as to shift the sheet in the reverse direction, as already described in connection with the shifting-bar
 25 37. This shifting-bar is provided at intervals with bridge-pieces 59, secured to and moving with said bar and extending outward therefrom in each direction over the bed-plate 60, in which the shifting-bar travels. The
 30 central portion of each bridge-piece is depressed to receive the fastening-screw 61, which connects it with the bar, and those portions of said bridge-piece immediately adjacent to its central portion are elevated, the
 35 extremities being inclined outward and downward toward the surface of the plate in each direction, as shown in Fig. 10. The bridge-pieces are preferably constructed of some elastic metal, such as brass, and serve to hold
 40 the sheets above the bed-plate 60 and prevent adhesion to the same.

In order to effectually control the feed of the tapes, we employ between them intermediate slats 62, which are capable of being vertically adjusted relatively to the plane of the tapes, so as to control the bearing of the sheets upon said tapes. This adjustment may be effected in any suitable manner; but we prefer for this purpose the construction
 50 shown, in which the slats are secured at one end to a rock-shaft 63, having a vertical arm 64 at each end, against which arm an adjusting-screw 65 bears, said screw passing through a threaded lug 66 on the frame of the machine. By this means the slats may be readily
 55 and quickly adjusted relatively to the tapes and will thereby control the frictional contact between the sheets and tapes, and consequently the feed.

60 Heretofore it has been customary to employ with machines of this description front guides to determine the position of the front edge of the sheet at the time when it is seized by the feed mechanism of the press or folder, and such guides have been adjustable for
 65 the purpose of varying this position. It has

also been proposed to employ at this point a stop mechanism which will stop the press or folder in case of the non-arrival of the sheet at a position which will bring it in contact
 70 with these guides. These devices have, however, been mounted separately from the guides, and as a consequence whenever the guides have been adjusted it has also been necessary to readjust the stop devices and
 75 bring them into proper relative position with the guides, a matter requiring considerable time and skill. We have avoided this difficulty by combining the stop-motion-controlling device with the guide in such a manner
 80 that its position relatively to the guide is permanent and that it is adjusted along with the guide by the same act which adjusts this latter. In Figs. 3 and 4 of the drawings we have shown in detail a front guide comprising a guide-plate 67, against which the
 85 front edges of the sheets successively abut, said plate being carried by an arm 68, threaded, as shown, at 69, and adjustable in a sleeve 70 to determine the position of the guide-plate. Mounted on the face of the plate 67
 90 is a pivoted arm 71, having contact-pieces 72, which when said arm is depressed are flush with the face of the plate, which latter is slotted to permit them to recede to this position. 73 represents an arm extending rearward from the pivoted arm 71 and carrying a valve 74, which controls the mouth of an exhaust-tube 75. The parts are so constructed
 95 that the arm 73 is normally depressed and the valve 74 normally open, as shown in Fig. 4^a, while the contact-pieces 72 project beyond the face of the plate 67, their position being controlled by a stop-arm 76, which contacts
 100 with the face of the plate when the parts are in this position. The mechanical connections, which are old and well known, are such that if the exhaust-tube 75 remains open at the time when a sheet should come
 105 into contact with the guide 67 the press or folder will stop. It will be understood, of course, that when the coming sheet reaches the front guides its front edge will come into contact with the contact-pieces 72 and will raise the lever 73 and close the mouth of the
 110 exhaust-tube 75 by means of the valve 74, as shown in Fig. 4. In case of the non-arrival of a sheet the tube will not be closed and the press or folder will stop. It will be at once seen that the front guides may be adjusted
 115 without disturbing the relation between them and the stop-motion-controlling devices, these relations being permanent, so that said devices are adjusted along with the guides and are always in proper operative position. 125

We do not wish to be understood as limiting ourselves to the precise details of construction hereinbefore described and shown in the accompanying drawings, as these may obviously be modified without departing from
 130 the principle of our invention.

We claim—

1. In a machine of the character described, a pneumatic-suction-cup bracket comprising a base having vertical ways, a bracket proper mounted to slide on said ways and carrying the suction-cup, and means for adjusting the bracket proper relatively to said base, substantially as described. 5
2. In a machine of the character described, a pneumatic-suction-cup bracket comprising a base having vertical ways, a bracket proper carrying the suction-cup and adapted to slide on said ways, a feed-screw for adjusting the bracket proper on said ways, and means for securing the bracket proper after adjustment, substantially as described. 10 15
3. In a machine of the character described, the combination, with a suction-cup bracket, of an arm secured to said bracket at one end, carrying the cup at its other end, and provided with an intermediate joint and clamping means whereby the angle of the cup may be varied, substantially as described. 20
4. In a machine of the character described, the combination, with a suction-cup bracket having a horizontal socket, of an arm adjustable both longitudinally and angularly in said socket, said arm carrying the suction-cup and being provided with a joint and clamping devices whereby the two sections of said arm may be adjusted at varying angles, substantially as described. 25 30
5. In a machine of the character described, a suction-cup bracket comprising a base, and a bracket proper vertically adjustable thereon, said bracket proper being provided with a horizontal socket, in combination with a jointed arm longitudinally and angularly adjustable in said socket and having its two sections angularly adjustable relatively to each other, and the outermost or free end being provided with a suction-cup, substantially as described. 35 40
6. In a machine of the character described, the combination, with a press or folding-machine, a suction mechanism for lifting the sheet from the pile and its delivery-rollers, of sheet-transferring tapes intermediate said devices divided into two sections having different speeds, that section adjacent to the lifting mechanism having a speed equal to the delivery thereof and that section adjacent to the press or folding-machine having a slower speed, substantially as described. 45 50
7. In a machine of the character described, the combination, with a press or folding-machine and a pneumatic lifting mechanism and its delivery-rollers, of a sheet-transferring mechanism intermediate the two consisting of two sections having differing speeds, that one adjacent to the lifting mechanism having a speed equal to that of its delivery and the other section a slower speed, and stop mechanism for arresting the sheet before its delivery from the first section to the second section, substantially as and for the purpose described. 55 60 65
8. In a machine of the character described, the combination, with a transferring mechanism comprising two sections or sets of tapes of different speed, of stops for arresting the sheet at the end of the first section, means for shifting the sheet laterally while thus arrested and means for delivering the laterally-shifted sheet to the second or slower-moving section, substantially as described. 70 75
9. In a machine of the character described, means for shifting the sheet laterally comprising a shifting-bar, a lever having a link connection with said bar and provided with a transverse arm, and an operating-rod having an adjustable connection with said lever, whereby its point of attachment may be shifted from one side of the pivot to the other to reverse the direction of movement of the shifting-bar, substantially as described. 80 85
10. In a machine of the character described, delivery-calipers comprising a fixed arm and a movable arm pivotally connected therewith and provided with an adjusting-screw bearing on the fixed arm, substantially as described. 90
11. In a machine of the character described, delivery-calipers comprising a fixed arm, a movable arm pivotally connected therewith and provided with an adjusting-screw bearing on the fixed arm and with a vertical open-mouthed slot, and a clamping-screw passing through said slot into the fixed arm, substantially as described. 95
12. In a machine of the character described, the combination, with a transverse plate and a shifting-bar movable therein, of bridge-pieces secured to and moving with the shifting-bar and having their surfaces elevated above said plate, substantially as described. 100 105
13. In a machine of the character described, the combination, with a transverse plate and a shifting-bar movable therein, of bridge-pieces having their central portions depressed and secured to the shifting-bar and their body portions adjacent thereto elevated above the plate and inclined downward toward the surface of the same in each direction, substantially as described. 110
14. In a machine of the character described, the combination, with the transfer-tapes, of intermediate stationary slats and means for adjusting said slats relatively to the plane of the tapes to relieve the tapes of more or less of the weight of the sheets, substantially as described. 115 120
15. In a machine of the character described, the combination, with the transfer-tapes, of intermediate slats, a transverse rock-shaft to which said slats are secured at one end, and means for angularly adjusting said rock-shaft, substantially as described. 125
16. In a machine of the character described, the combination, with the transfer-tapes, of intermediate slats, a rock-shaft to which said slats are secured at one end, said rock-shaft being provided with a radial arm, and an ad- 130

justing-screw bearing against said arm, substantially as described.

17. In a machine of the character described, the combination, with a press or other mechanism to be fed having an adjustable front guide, of a sheet-feeding mechanism for feeding the sheets against said guide, and a stop-motion-controlling device mounted on said

guide and adjustable along with the same, substantially as described.

GEORGE R. WILLIAMS.
WILLIAM C. WILLIAMS.

Witnesses:

L. F. MCCREA,
FREDERICK C. GOODWIN.