

(19)



(11)

EP 2 319 347 B1

(12)

EUROPEAN PATENT SPECIFICATION

(45) Date of publication and mention of the grant of the patent:
27.11.2019 Bulletin 2019/48

(51) Int Cl.:
A44C 5/00 (2006.01) G04B 37/00 (2006.01)

(21) Application number: **10185960.1**

(22) Date of filing: **07.01.2004**

(54) Snapping and hinging arrangements for watches

Schnapp- und Gelenkanordnungen für Uhren

Agencements d'encliquetage et de charnière pour des montres

(84) Designated Contracting States:
AT BE BG CH CY CZ DE DK EE ES FI FR GB GR HU IE IT LI LU MC NL PT RO SE SI SK TR

(30) Priority: **07.01.2003 US 438755 P**
31.10.2003 US 516661 P

(43) Date of publication of application:
11.05.2011 Bulletin 2011/19

(62) Document number(s) of the earlier application(s) in accordance with Art. 76 EPC:
04700640.8 / 1 594 381

(73) Proprietor: **Disney Enterprises, Inc.**
Burbank, CA 91520 (US)

(72) Inventors:
• **Kraus, Stephanie**
Glendale, CA 91206 (US)

- **Heatherly, Chris**
Pasadena, CA 91104 (US)
- **Ouye, Randal**
La Crescenta, CA 91214 (US)
- **Nishioka, Julie**
Glendale, CA 91208 (US)
- **Holland, John**
San Francisco, CA 94103 (US)
- **Sand, Jeffrey**
San Francisco, CA 94107 (US)

(74) Representative: **Nederlandsch Octrooibureau**
P.O. Box 29720
2502 LS The Hague (NL)

(56) References cited:
GB-A- 2 112 549 GB-A- 190 926 723
US-A- 2 094 322 US-A- 2 512 992

EP 2 319 347 B1

Note: Within nine months of the publication of the mention of the grant of the European patent in the European Patent Bulletin, any person may give notice to the European Patent Office of opposition to that patent, in accordance with the Implementing Regulations. Notice of opposition shall not be deemed to have been filed until the opposition fee has been paid. (Art. 99(1) European Patent Convention).

Description

BACKGROUND

Field of the disclosure

[0001] The present application relates to snapping and hinging arrangements. More particularly, the present application is directed to snapping and hinging arrangements to be used in fastenable articles, and their associated construction and uses. The present application or disclosure also relates to watches and arrangements, uses and methods associated therewith.

Description of the background art

[0002] When using a fastenable article, it is often desirable to use fastening means which are easy and simple to use. This is particularly true when the fastenable articles are clothing items, such as shoes, belts, phone holders and time pieces.

[0003] With reference to the latter case, for example, watches have been typically provided with various buckle-type fastening means in order to fasten portions of the band together and thus secure the timepiece to a wearer's wrist, for example. While this method is sufficient to secure timepieces to a wrist, the intricacies involved in using a buckle/clasp-type of fastening mechanism may prove to be too difficult/complex to operate without encountering difficulty and frustration, especially for young children or persons with limited manual dexterity.

[0004] Generally the concept of time is also often difficult and complex for children to comprehend.

[0005] A configuration that provides secure fastening and ease of operation, both for fastening and unfastening, as well as a method to teach children how to tell the time and to relate time to various daily events, is clearly needed.

[0006] Also, in the case of wristwatches, it is sometimes desirable to transfer the watch from one band to another, for example, to use a band that better coordinates with other fashion items. However, most existing mechanisms used to attach watches to watchbands use very small pins, making the band difficult and time consuming to remove and install. Hence, there is a need for an improved attachment mechanism that provides for quick and easy removal and installation of different watchbands on a wristwatch. An example of a watch assembly having a housing and a spring element is known from GB2112549

[0007] Furthermore, other fashion items, such as pins and broaches are typically attached to clothing and other items using pins, and other mechanisms, that are awkward and difficult to use. The pins can also damage the fabric through which it is inserted. There is need for an improved attachment mechanism for pins and broaches that is easy to use and does not damage the fabric of the item to which it is attached.

SUMMARY OF THE DISCLOSURE

[0008] The present disclosure relates to a snapping arrangement and a hinging arrangement to be used in connection with items. In particular, the disclosure relates to a snapping arrangement to be applied on a strap.

[0009] The strap can be used for fastening clothing items such as shoes, belts, phone holders etc. One embodiment refers to time measuring devices, such as watches. With reference to watches, the snapping mechanism allows the strap to be secured on a portion of the human body, such as the wrist or the ankle.

[0010] The snapping mechanism utilizes cooperation of two assemblies on the strap, a magnet assembly and a metal assembly. The magnet assembly is located proximate to or at one end of the strap. The metal assembly is located proximate to or at the other end of the strap. During use, the magnet assembly is secured to the metal assembly. The magnet assembly becomes secured to the metal assembly through a snap action, where contact between the magnet assembly and the metal assembly is achieved at least in part by means of a magnetic engagement between the magnet assembly and the metal assembly.

[0011] Various embodiments are provided due to the different shape and functions of magnet/metal assemblies.

[0012] According to a first unclaimed aspect, a magnet assembly suitable to be connected to a metal assembly in an engaging fashion is disclosed, comprising: an upper portion; and a lower magnetic portion connected with the upper portion.

[0013] The magnet assembly is preferably located on a strap, and the lower magnetic portion is preferably connected with the upper portion through the strap.

[0014] The upper portion of the magnet assembly preferably includes a protruding element and the lower portion, a recessed region. The protruding element can then engage with the recessed region to secure the magnet assembly in position. The upper portion and lower magnetic portion can also be secured to the strap by means of pressure forces resulting in a press fit, pop-in fit magnet assembly.

[0015] According to a second unclaimed aspect, a magnet assembly suitable to be connected to a substantially flat item, is disclosed, comprising: a cap having an upper part and a lower part; and a lower magnetic portion contacting the cap, the cap securing the assembly to the substantially flat item.

[0016] In one preferred embodiment, the lower magnetic portion is partially recessed into the cap.

[0017] According to a third unclaimed aspect, a magnet assembly suitable to be connected to a substantially flat item, is disclosed, comprising: a tip; a lower magnetic portion; and a retention pin.

[0018] According to a fourth unclaimed aspect, a metal assembly, suitable to be secured to a substantially flat item, is disclosed, comprising: one or more rivets; and

one or more metal elements. Each of the one or more metal elements has a mating portion and an engaging portion and each of the one or more rivets is connected to each of the one or more metal elements by the engaging portion, thereby securing the assembly to the item. The metal assembly is further connectable to a magnet assembly in a mating fashion.

[0019] The metal element and rivets can be switched in the assembly so that the upper part of the rivets constitute the mating portion and the lower part the engaging portion, and the metal elements connect and secure the assembly to the item.

[0020] The metal assembly can also comprise a rib connecting the metal elements, preferably adjacent to the metal elements. The rib of the disclosure can be an additional part of the metal elements or integral to the metal element and comprises a spine portion having a plurality of holes and a plurality of mating portions.

[0021] Preferred embodiments are ones where the lower magnetic part as well as the mating portion of the metal element/rivet are arc-bean shaped.

[0022] According to a fifth unclaimed aspect, a snapping mechanism or arrangement suitable to secure portions of a substantially flat item, is disclosed. In particular the snapping mechanism or arrangement is suitable to secure portions of the band of a watch, which comprises the magnet assembly and a metal assembly described in the present disclosure. The watch band, including the snapping mechanism, can easily be put on and taken off. This is particularly advantageous when the watch band is used by children and people with limited manual dexterity.

[0023] According to a sixth unclaimed aspect, a substantially flat item, in particular the band of watch, is disclosed, comprising the disclosed snapping mechanism or arrangement.

[0024] According to a further unclaimed aspect, a process is disclosed for manufacturing a substantially flat item herein disclosed. The process comprises including the snapping mechanism disclosed herein in the substantially flat portion of said item.

[0025] The present disclosure also provides a hinging assembly, to be connected to an item, for example to a watch case. In this example, the watchcase including the hinging assembly can be attached to items, for example a strap, in particular the strap described above. Other exemplary items to which the hinging assembly may be attached include, without limitation, clothing items, backpacks and other accessories, for example. An advantage of the hinged watch case is the ease in removing and replacing watch bands from the hinged watch case.

[0026] In one embodiment, the hinging assembly is combined with and attached to a watch case. However other embodiments are possible, where the hinging assembly is able to be attached to other objects such as jewelry, buttons, fashion items etc.

[0027] In particular, the hinging assembly described below is attached to an element to be displayed, shown

or just carried, and allows that element to be applied, by means of a spring action exerted through the hinging assembly, on items such as clothing items, bags, books, hats, back pack, straps etc. In case the element is a watch case, the hinging assembly makes the hinged watch case applicable to various items other than a watch band.

[0028] Therefore according to the invention a leaf spring element according to claim 1 is disclosed, having a first lateral portion, a second lateral portion and a central portion acting as a spring and located between the first lateral portion and the second lateral portion.

[0029] Each first and second lateral portions have a substantially rectangular shape and comprise a first corner facing the central portion and a slanted leg. Each slanted leg comprises a first leg portion substantially lying in a first plane, and a second leg portion substantially lying on a second plane different from the first plane. In a preferred embodiment the first plane is substantially perpendicular to the second plane. The second leg portion of each slanted leg ends with an hollow section or aperture.

[0030] The central portion of the leaf spring element is a bent central portion having a substantially trapezoidal shape and having a first slanted edge and a second slanted edge.

[0031] The leaf spring element of the invention further comprises first and second cut sections that separate the central portion from the first and second lateral portions respectively. Each of first and second cut sections have a distal end and a proximate end, wherein the distal end is located between the first or second slanted edge and the first corner of the first or second lateral portions.

[0032] In a preferred embodiment of the leaf spring element of the invention, each of the first and second lateral portions comprises a second corner and a third corner, both distal to the central portion. A first tooth located adjacent the second corner and a second tooth located adjacent to the third corner, are also comprised in each first and second lateral portion. In particular the first and second teeth are located in a third plane and the first and second lateral portions located in a fourth plane different from, and preferably perpendicular to, the third plane.

[0033] According to a further unclaimed aspect, a process for manufacturing a leaf-spring element, is still disclosed, comprising: annealing a material; cutting the annealed material; bending the cut annealed material; and heat treating the bent cut annealed material. Cutting may be accomplished by any appropriate method known in the art. An exemplarily useful method utilizes a laser or lasers to cut.

[0034] The leaf spring element manufactured by the process of the disclosure is preferably the leaf spring element of the disclosure.

[0035] According to a further unclaimed aspect, a hinging assembly is disclosed, comprising the leaf spring element described herein and a hinge pin allowing connection with an item.

[0036] In one unclaimed aspect, an item comprising

the hinging assembly herein described is disclosed, in particular a watch.

[0037] According to a further unclaimed aspect, a base element to be used with a watch case, is disclosed. The base element comprises a substantially circular central portion and two side portions, often referred to as cuffs, connected and integral with the central portion.

[0038] The central portion has a first curved edge and a second curved edge and comprises along the first curved edge a hinging region and in proximity of the second curved edge a recessed region. The hinging region allows the base element to be hingedly connected with the watch case and the recessed region provides further connection between the base element and the watch case.

[0039] In particular the recessed region can be a locking region which allows locking between the base element and the watch case. The recessed region can also provide a recess for a crown of the watch case.

[0040] The side portions of the base element of the disclosure can be substantially trapezoidally shaped. A substantially rectangular region, which can be centrally disposed and slightly raised with respect to a remaining part of the internal side can be included as part of the base element.

[0041] According to a further unclaimed aspect, a hinging assembly is disclosed, which comprises a watch case and the base element described herein.

[0042] In particular, a hinge-pin can be positioned in the hinging region of the base element, and connect the watch case with the base element. The watch case can comprise an external side visible during normal use of the watch and an internal side not visible during normal use of the watch. The internal side can have an overall peripheral shape substantially matching a peripheral shape of the base element.

[0043] The watch case in the hinging assembly can comprise a crown. In this case the internal side can be so shaped to allow the crown to come into engageable connection with the recessed region of the base element.

[0044] The internal side of the watch case of the hinging assembly may also comprise a substantially rectangular region, which can be centrally disposed and slightly raised with respect to a remaining part of the internal side.

[0045] The hinging assembly can be adapted to be used with a watch band. The watch band can be inserted between the watch case and the base element. In particular, the watch band may be hosted in the substantially rectangular region of the watch case, and/or in the substantially rectangular region in the base element. The watch band may comprise a magnet assembly, a metal assembly of the disclosure, or a snapping mechanism of the disclosure.

[0046] According to a further unclaimed aspect, a watchband is disclosed, comprising a portion having a shape substantially matching the shape of a watchcase. The watchband of the disclosure can be advantageously used with the hinging assembly of the disclosure.

[0047] The portion of the strap matching the shape of a watchcase is preferably substantially circular or substantially oval.

[0048] According to a further unclaimed aspect, a watch system is disclosed, including a first visual display showing a time, and a second visual display showing indication of an event associated with the time shown by the first display. The event is variable in accordance with the time shown by the first display.

[0049] The first display may show time in an analog or in a digital manner according to a 12-hour and/or a 24-hour arrangement. The arrangement may show time only by means of an hour arrangement, or also by means of a hours-minutes or hours-minutes-seconds arrangements. The watch system may also comprise a sound emitting assembly.

[0050] The indication of an event in the second display can be an icon thematically associated with the time shown in the first display, as well as a wording, an animation, a sound effect or a combination thereof. An assembly providing at least one of those effect can be comprised in the watch system.

[0051] The event can also be variable in accordance with the skills of the user.

[0052] According to a further unclaimed aspect, a method to teach a user how to tell the time, is disclosed. The method comprises the use of the watch system herein described.

[0053] According to a further unclaimed aspect a watch band is also disclosed, to be used in conjunction with a watchcase having an upper surface and a lower surface. The watch band of the disclosure comprises a portion having a shape substantially matching a shape of the lower surface of the watchcase.

[0054] Such portion is preferably located in a substantially central position in the strap, and has preferably a substantially circular or a substantially oval shape.

[0055] The foregoing and other objects, features and advantages of the present disclosure will be apparent to those of skill in the art from the following detailed description which makes reference to several figures which are exemplary and non-limiting and of which Figures 33 to 42 depict the leaf spring of the invention.

45 BRIEF DESCRIPTION OF THE DRAWINGS

[0056]

50 Figure 1 shows a perspective view of an embodiment of a magnet assembly;

Figure 2 shows a sectional perspective view of a the magnet assembly of Figure 1 on a strap;

55 Figure 3 shows a cross-sectional view of a magnet arrangement comprising the magnet assembly of Figure 1 and the strap;

Figure 4 shows a top view of a further embodiment of the magnet arrangement;

Figure 5 shows a bottom view of the embodiment shown in Figure 4;

Figure 6 shows a bottom view of a further embodiment of the magnet arrangement;

Figure 7 shows a top view of the further embodiment of Figure 6;

Figure 8 shows a top view of a still further embodiment of the magnet arrangement;

Figure 9 shows a bottom view of the still further embodiment of Figure 8;

Figure 10 shows a perspective view of a magnet portion;

Figure 11 shows a perspective cross-sectional view of a magnet arrangement including the magnet portion of Figure 10;

Figure 12 shows a further cross-sectional view of the magnet arrangement of Figure 11;

Figure 13 shows a top view of an embodiment of an exemplary metal arrangement;

Figure 14 shows a bottom view of the embodiment of Figure 13;

Figure 15 shows an exploded cross-sectional view of the embodiment of Figures 13 and 14;

Figure 16 shows a top perspective view of the metal arrangement of Figures 13 to 15;

Figure 17 shows a top view of a further embodiment of the metal arrangement;

Figure 18 shows a bottom view of the further embodiment of Figure 17;

Figure 19 shows a top view of a still further embodiment of the metal arrangement;

Figure 20 shows a bottom view of the still further embodiment of Figure 19;

Figure 21 shows a partial cross-sectional view of another embodiment of the metal arrangement;

Figure 22 shows a partial perspective cross-sectional view of the embodiment of Figure 21;

Figure 23 shows a front cross-sectional view of another embodiment of the metal arrangement;

Figures 24A-24C show a metal element in a stamped and tumbled condition, in a bent condition and in a folded condition;

Figure 25 shows insertion of the metal element of Figure 24B in a strap;

Figure 26 shows a partial bottom perspective view of a strap and a metal element;

Figure 27 shows a cross-sectional view of a strap;

Figures 28-32C show watches embodying exemplary snapping arrangements;

Figure 33-36 show a leaf-spring element according to the invention;

Figure 37 shows a perspective view of a first embodiment of a hinging assembly;

Figure 38 shows a cross-sectional view of the hinging assembly of Figure 37;

Figure 39 shows a possible use of the hinging assembly of Figures 37 and 38;

Figure 40 shows an exploded view of a strap with a magnet assembly and a metal assembly;

Figures 41 and 42 show cut sectional view of a watch case;

Figure 43 shows a top view of a base element to be used in a further embodiment of the hinging assembly;

Figures 44A and 44B show two different embodiments of hinging assemblies comprising a base element;

Figure 45A and 45B show a hinging assembly in an open condition hosting a watch band;

Figures 46 and 47 show exemplary uses of the hinging assembly;

Figures 48 and 49 show a "first level" system to teach how to tell time;

Figures 50 and 51 show a "second level" system to teach how to tell time; and

Figures 52 and 53 show a third level system to teach how to tell time.

DETAILED DESCRIPTION OF THE DISCLOSURE

[0057] A snapping arrangement is initially disclosed. The arrangement comprises a strap and two cooperating assemblies on the strap, a magnet assembly and a metal assembly. The magnet assembly is located proximate to or at one end of the strap. The metal assembly is located proximate to or at the other end of the strap. During use of the strap, for example on the wrist or ankle of a user, the magnet assembly is secured to the metal assembly. The magnet assembly becomes secured to the metal assembly through a snap action, where contact between the magnet assembly and the metal assembly is achieved at least in part by means of a magnetic engagement between the magnet assembly and the metal assembly.

[0058] Several embodiments are shown in the present disclosure exhibiting different shapes and functions of the magnet/metal assemblies.

1. Magnet assembly

[0059] Figures 1-3 show a first embodiment of a magnet assembly (1) on a strap (2), comprising an upper portion (3) and a lower portion (4). The upper portion (3) is usually button-shaped and does not need to be magnetic. For example, it can be made of plastic. The lower portion (4) is magnetic and can be cylindrical in shape.

[0060] The lower portion (4) can be connected with the upper portion (3) in a variety of ways.

[0061] For example, the upper portion (3) can have an element protruding from its bottom surface and engaging with a recess in the upper surface of the lower portion (4). To this effect, a hole will be formed in the strap (2), near a tip (5) of the strap. Therefore, the upper portion (3) and the lower magnetic portion (4) pop into place and engage one another, thus forming the magnetic assembly.

[0062] Figures 4-5 show in more detail an upper surface (6) and a lower surface (7) of the strap. With reference to those figures, and alternatively to what is disclosed above, the upper portion (3) of the magnet assembly can be glued together with the upper surface (6) of the strap, and the lower magnetic portion (4) of the magnet assembly can be glued together with the lower surface (7) of the strap. Figure 5 also shows a rib (8), which could be added to the magnetic assembly to increase stability of the assembly on the strap. A further kind of connection between the upper portion (3) and the lower magnetic portion (4) is a "press fit" connection, where the upper portion (3), the portion of the strap (2) close to the tip (5), and the lower magnetic portion (4) are kept into place by means of pressure forces.

[0063] Figures 6-7 show a second embodiment of the magnet assembly on the strap (2), comprising a cap (9), enclosing both the upper portion (3) and the lower magnetic portion (4). The cap (9) forms a space (not shown), between the upper portion (3) and the lower magnetic

portion (4), for an end portion of the strap (2) to be inserted before the components of the magnet assembly are snapped into place. Also in this case, a hole will be formed in the strap (2).

[0064] It should be noted that the presence of the cap (9) under the upper portion (3) and above the strap (2) on the non-magnetic side of the magnet assembly provides a pleasant aesthetic, mushroom-like aspect. Additionally, stability of the end portion of the strap is improved. Alternatively the cap itself could also provide a tip of the strap, thus not requiring the strap to be placed in the middle of the cap. Connection between the cap/tip and the strap (2) can be achieved by mechanical means, such as screws (10,11) as schematically shown in Figure 7.

[0065] Alternatively to what is shown in Figures 6 and 7, the cap (9) can be provided instead of (and not in addition to) the upper portion (3). In this case, the aesthetic effect due to the presence of the upper portion can be obtained by suitable reshaping of the cap element (9).

[0066] Figures 8-12 show a third embodiment of the magnet assembly on the strap (2), where cap (9) also acts as upper portion. In this embodiment, the lower magnetic portion of the magnet assembly is provided by an arc- or bean-shaped element (13). The shape of the element (13) is better shown in perspective in the enlargement of Figure 10. Figures 11 and 12 are partial cross sections better showing some of the details of the third embodiment. In particular, the cap (9) comprises a recessed area (14) on its top. Additionally, a retention pin (15), preferably a metal retention pin, is provided to connect the strap (2) with the cap (9). In this way the whole assembly, including lower magnetic portion (13), is kept in place by means of mechanical forces. If desired, an upper portion, as shown in the previous Figures 1-4, can be provided in place of the recessed area (14). It should be noted that the connection between the upper portion and the lower magnetic portion (12) can be obtained in a variety of ways, easily determinable by the person skilled in the art upon reading of the present disclosure. For example, the arc-shaped portion could be press-fit into the cap portion, or partially recessed into the cap portion.

2. Metal assembly

[0067] The metal assembly is located on an end of the strap (2) opposite the end on which the magnet assembly is located. In this way, when the strap (2) is closed, in a circular fashion, one assembly will mate with the other.

[0068] Figures 13-16 show a first embodiment of a metal assembly on the strap (2). The metal assembly comprises a plurality of rivets (16), each having a top or mating surface (17) and a bottom or engaging surface (18), as shown in the exploded view of Figure 15. Each rivet (16) engages into a corresponding metal element (19) by means of its engaging surface (18), as also shown in the exploded view of Figure 15. The metal elements (19) are

located on the lower surface (7) of the strap (2), proximal to the skin of the user. The rivets (16) are located on the upper surface (6) of the strap (2), distal to the skin of the user, during use. The substantially circular shape of the mating surfaces (17) corresponds to the substantially circular shape of the bottom surface of the lower magnetic portion (4) of the magnet assembly, shown in some of the previous Figures. Magnetic engagement of the bottom surface of the lower magnetic portion (4) with one of the mating surfaces (17), one of the mating surfaces (17) being chosen among the others in accordance with the desires or size of the wrist or ankle of the user, allows closure of the strap (2). Of course, stability of the closure of the strap (2) is maximized when there is geometric correspondence between the bottom surface of the lower magnetic portion (4) of the magnet assembly and the mating surface (17). However, geometric correspondence between the mating surfaces is just a preferred embodiment, and not a necessary feature of the present disclosure. Additionally, the person skilled in the art will recognize, upon reading of the present disclosure, many geometric alternative shapes, such as square, rectangular, triangular, hexagonal, etc. shapes, both for the bottom surface of the lower magnetic portion (4) of the magnet assembly and the mating surface (17), are possible.

[0069] Pressed rivet technology, preferably used to realize the assembly of Figures 13-16, is known to the person skilled in the art and does not need to be described in detail. For example, an overmolding process could be used, i.e. the strap (2) is first molded and then the rivets (16) and metal elements (19) are molded into the strap (2), on opposite surfaces (6, 7) thereof.

[0070] Figures 17-20 show different shapes of the rivets and metal elements. For example, the shape of the mating surfaces of Figure 17 is suitable for use with the lower magnetic portion (13) shown in Figure 10. Spacing between the rivets (16) determines the number of rivets and consequently, the number of different sizes of the strap (2). In case the shape of the rivets (16) is such that the mating portion (17) is circular, spacing between the rivets (16) cannot be less than the diameter of the rivets (16), thus reducing the available design choices. For example, spacing between the rivets (16) in these embodiments is usually about 10 mm (about .4"). However, it should be noted that an arc- or bean- shape allows a better stability of the metal elements (19) when pressed into the strap. In particular, arc/bean-shaped metal elements have less tendency to pivot than circularly-shaped metal elements. Additionally, the presence of arc/bean shaped metal elements instead of circular elements allows for tighter spacing between the rivets (16), thus permitting a higher number of different sizes to be provided on the strap (2).

[0071] The metal assembly structure can be reinforced by means of a rib or spine structure (20) placed in the strap (2) and mechanically connecting the various elements of the metal assembly, as shown, for example, in Figure 19. The presence of a reinforcing structure pro-

vides for a better stability of the assembly and helps avoid undesired pivoting movement of the rivets and metal elements during use of the strap (2). According to a first aspect (not shown in the Figures), the rib structure could be additional to, or independent from, the plurality of rivets (16) and metal elements (19), to be placed, for example, between the rivets (16) and the metal elements (19), and comprising a plurality of holes in correspondence with the junction between each metal element and its corresponding rivet.

[0072] Figures 21-22 show a partial cross sectional view and a partial perspective view, respectively, of a second embodiment (21) of the rib structure, where the rib structure (21) is integral with the plurality of metal elements. Therefore, according to this second embodiment as shown in detail in Figure 22, the integral rib structure (21) comprises a spine portion (22) comprising a plurality of holes (23) and a plurality of mating metal portions, each having a first side (24A) and a second side (24B), placed in correspondence with a hole (23) and having a shape matingly corresponding to the shape of a lower magnetic portion (4) of the magnet assembly (1).

[0073] According to a further embodiment of the metal assembly in accordance with the teachings of the present disclosure, the metal-element/rivet combination is replaced by a plurality of staple elements. Figure 23 is a cross-sectional view and shows one of the staple elements (25) inserted into corresponding openings or slots (26) of the strap (2). In particular, the strap (2) is provided with two slots (26) for each of the staple elements (25) to be placed.

[0074] Figures 24A-24C show the various shapes of each staple element (25) during a manufacturing process. During the manufacturing process, each staple element initially exhibits a first stamped and tumbled condition (A), Figure 24A, with an arcuated, for example substantially semi-circular, shape, having an outer periphery (27), an inner periphery (28), and two lateral ends (29, 30). The staple undergoes a first bending operation, Figure 24B, and is bent along its lateral ends (29, 30) to provide a bent condition (B) comprising an upper, unbent, mating portion (31), a first bent portion (32) and a second bent portion (33). Further to this, one or more staples are inserted into the strap (2), as shown in Figure 25. Each staple is placed or loaded into position by inserting its first and second bent portions (32, 33) into slots (26) provided in the strap (2) and shown in Figures 25 and 26. At the end of this step, the mating portions (31) of each loaded staple in its condition (B) have reached their position in the strap (2). Subsequent to this, the first and second bent portions (32, 33) are bent or folded again, this time around the strap (2), to reach a completely folded condition (C), as shown in Figure 24C, which shows a staple alone for clarity reasons. Figure 26 shows this last step in more detail, showing the bent portions (32, 33) both in their (B) condition (32B, 33B) and their (C) condition (32C, 33C).

[0075] As shown in Figures 23 and 25, the preferred

embodiment also provides for a particular structure of the area surrounding the slots (26) for each staple (25). In particular, for each staple (25), the region comprising the two slots (26) is recessed and comprises a step-like structure with two raised or stepped portions (34, 35) and one lower flat portion (36), on which the staple (25) is to be placed. Each slot (26) is placed in correspondence to the region between a stepped portion (34, 35) and the flat portion (36). In this way, a more stable mechanical structure is obtained, and the overall shape also has a more pleasant aesthetic aspect.

3. The Strap

[0076] The magnetic and metal assembly have been described heretofore with reference to a strap. However, it should be noted that they could be applied on any arrangement for which a cooperation between two mating elements is required. Key-holders, wallets, belts, etc. represent possible, non-limiting examples, of elements on which the assemblies could cooperate.

[0077] With reference to the strap, such strap could be of any material or shape. Should printing on the strap be required, a preferred embodiment shown in cross-section of the strap is shown in Figure 27 and provides for a smooth convex upper surface (37) of the strap and a smooth concave lower surface (38) of the strap.

[0078] In a further preferred embodiment, the strap of the disclosure may include a portion having a shape that matches the shape of the interior surface of a watchcase. Such portion is preferably substantially centrally located in the strap. In particular the portion can have a substantially circular or oval shape and may be used with a hinging assembly later disclosed in the present disclosure. See, for example, the embodiments shown in Figures 40 and 45B, below.

4. The watch

[0079] The strap described heretofore can be used to attach clothing items such as shoes, belts, phone holders etc. In particular, the strap of the present disclosure can be the band of a watch.

[0080] Figures 28-32C show various watches embodying exemplary snapping arrangements described according to the present disclosure, and will not be described herein in detail, as these embodiments are understandable to the person skilled in the art, in light of the present disclosure.

5. The Hinging Mechanism

[0081] The present disclosure also provides a hinging mechanism to be connected to an item, such as a watch case. The hinging mechanism allows the watch case to be attached, for example, to a strap as described above or to other straps and also allows the watch case to be applied to items unrelated to the watch, such as clothing

items.

[0082] The hinging mechanism according to the present disclosure is shown in perspective in Figure 37 and may comprise a leaf spring element, as shown in Figures 33-36, which disclose a multi-step process for forming the leaf spring element.

[0083] Figure 33 shows the leaf spring element (39) after a first annealing and cutting operation. The leaf spring element can be made of steel. Cutting can be performed by laser cutting, or any other appropriate cutting operation, as known in the art, and will not be here described in detail. The leaf spring element (39) of Figure 33 comprises three main portions: a first lateral portion (40), a second lateral portion (41) and a central portion (42). The central portion (42) will act as a spring and is located between the first lateral portion (40) and the second lateral portion (41). The central portion (42) has a substantially trapezoidal shape, with an upper edge (43) and two slanted edges (44, 45). Each of the two lateral portions (40, 41) has a substantially rectangular shape. Preferably, one of the two lateral portions (40, 41) is the mirror image of the other. A first cut section (46) and a second cut section (47) separate the central portion (42) from the first and second lateral portions (40, 41), respectively. Preferably the first and second cut sections (46, 47) are specular to each other. The first cut section (46) is substantially parallel to the first (44) of the two slanted edges of the central portion (42). The second cut section (47) is substantially parallel to the second (45) of the two slanted edges of the central portion (42). In a preferred embodiment, both cut sections (46, 47) extend only along a part of the slanted edges (44, 45) of the central portion (42). Each cut section (46, 47) has an upper or distal end (48, 49) and a lower or proximate end (50, 51). The upper or distal end (48, 49) of each cut section (46, 47) is formed by a combination of a part of the shape of the slanted edge (44, 45) of the central portion (42) with one of the first corners (52, 53) of the first or respectively second lateral portion (40, 41). The lower or proximate end (50, 51) of each cut section has a circular contour.

[0084] The bottom region (54) of the leaf spring element (39) is an integral combination of the bottom regions of the central portion (42) and the two lateral portions (40, 41). In particular, the bottom region (54) has a semicircular overall shape, trifurcated at the top. In other words, the top portion of the bottom region (54) merges with the lower portions of the central portion (42) and the two lateral portions (40, 41). More specifically, the lower edge of the central portion (42) completely merges into the bottom region of the leaf spring element (39), while the lower edge of each of the lateral portions (40, 41) only partially merges into the bottom region (54) of the leaf spring element, the remaining portion of each lower edge forming two specular bottom side edges (55, 56) of the leaf spring element (39).

[0085] A small trapezoidal region (57) is also present, in correspondence with the central portion of the lower or outer semicircular edge (58) of the bottom region (54).

Finally a protruding slanted leg (59, 60) is formed on the top edge (61, 62) of each of the lateral portions (40, 41). Each leg (59, 60) ends with a hollow section (63, 64). The hollow sections (63, 64) will cooperate with a hinge pin, later shown, to allow engagement of the leaf spring element (39) with a watch case, for example.

[0086] Figure 34 shows the leaf spring element after a bending operation of legs (59, 60). In particular, only a portion of the legs (59, 60) is bent, so that each leg now comprises a first leg portion (65, 66) substantially lying on a first plane and a second leg portion (67, 68), substantially lying on a second plane different from, and preferably substantially perpendicular to, the first plane. The second plane where the second leg portions (67, 68) lie, is also preferably substantially perpendicular to a plane formed by the two lateral portions (40, 41). Additionally, the two second leg portions (65, 66) are substantially parallel to each other, to allow a correct lining up of a hinge pin, to be later described, once the hinge pin is inserted into the circular hollow sections (63, 64).

[0087] Figure 35 shows the leaf spring element after a further bending operation, where an upper part of the central trapezoidal portion (42) is bent towards the plane formed by the second leg portions (67, 68). Once bending of the central portion (42) is terminated, the central portion will exhibit a bending along its surface which attenuates as it approaches the proximity of its lower edge and is maximum in proximity of its upper edge (43).

[0088] A further bending operation (not shown) of the first and second lateral portions (40, 41) may be performed. Once bending of the first and second lateral portions (40, 41) is terminated, each lateral portion will exhibit a bending along its surface which attenuates as it approaches its lateral side edges (300, 301) and is maximum as it approaches the central portion.

[0089] Figure 36 shows a further step, where the leaf spring element of Figure 35 is heat treated. Preferably, before heat treating, teeth are formed, through bending (not shown) of second corners (303, 304) and third corners (305, 306) of the first and second lateral portions (40, 41).

[0090] Figure 37 shows a perspective view of the leaf spring element (39) when connected to a watch case (69), for example by means of the bent upper edge (43) and a hinge pin (70) placed through the hollow sections (63, 64) shown in the previous Figures. Figure 37 also shows teeth (71) on the spring leaf element (39), for example square or rectangular teeth. The teeth (71) are preferably formed before cutting and bending of the second and third corners of the lateral portions (40, 41). The teeth (71) allow better grasping of the item which will contact the spring element (39), to be placed, during use, between the spring element (39) and the watch case (69).

[0091] Figure 38 shows a partial cross sectional view of the arrangement shown in Figure 37, showing, in better detail the leaf spring element (39), one of the second leg portions (67) and the hinge pin (70).

[0092] Figure 39 shows one of the possible uses of the

hinging assembly, e.g., on a shirt of a user.

[0093] Figure 40 shows a perspective exploded view of a strap (2), with a magnetic assembly (72) and a metal assembly (73). The two assemblies have already been described with reference to some of the previous figures. The strap (2) also comprises a central circular recessed region (74), hosting the watch case (75). Also the watch case (75) is shown in an exploded view and comprises a lower plate or back plate (76), a casing (77), a crown (78), a watch surface or dial surface (79), and a lens (80). It will be appreciated that the structure of the watch case (75) is modular and easily assemblable. In particular, the lower plate (76) will fit into the recessed region (74), the casing (77) will be placed above the lower plate (76), the watch surface (79) will fit into the lower plate (76) and the casing (77) and the lens (80) will be placed above the watch surface (79). Also shown is an exploded view of the leaf spring element 39 and the hinge pin 70.

[0094] Figures 41 and 42 show cut sectional views of the watch case (75), together with the leaf spring element (39) and the pin (70).

[0095] A further embodiment of the hinging mechanism of the present disclosure may also comprise a base element as shown in Figure 43 to replace the leaf spring element shown in the previous figures.

[0096] Figure 43 shows a top view of a base element (81), i.e. a view of the internal side of the base element (81). The base element (81) comprises a substantially circular central portion (82) and two side portions (83, 84) connected with the central portion and integral therewith. In particular, the central portion (82) exhibits curved edges (85, 86). The central portion (82) comprises, along its curved edge (85) a hinging region (87), for example hinging cavities, which allow the base element (81) to be hingedly connected with the watch case. The central portion (82) further comprises a recessed region (88) located in proximity of its curved edge (86) to either allow locking of the base element (81) with the watch case or to provide a recess for the crown of the watch case.

[0097] The edges of the side portions (83, 84) may be bent to allow a better grasping of the item to be hosted in the hinging assembly (81).

[0098] The base element (81) may also comprise a path-providing region (203) allowing an item, such as a watch band, to be inserted. In particular, the region (203) can be a recessed region and include slightly raised edges. Preferably the shape of the region (203) matches the shape of the watchband to be hosted.

[0099] Figure 44A and Figure 44B show two different embodiments of the hinging assemblies comprising a base element. In the embodiment of Figure 44A, the base element (81) is flat. In the embodiment of Figure 44B the base element is slightly concave. In particular, Figure 44A shows a hinging assembly (89) comprising the base element (81) connected with a watch case (90) by means of a hinge-pin (91) positioned in the hinging region (87). The hinge-pin (91) can be a spring-hinge. The watch case (90) has an external side (92) visible during normal use

of the watch and an internal side (93) not visible during normal use of the watch. The internal side (93) has an overall peripheral shape substantially matching the peripheral shape of the base element (81). The internal side (93) allows the crown (94) to come into engageable connection with the recessed region (88) of the base element (81), for example after a watch band is inserted between the watch case (90) and the base element (81), as shown in the following figures.

[0100] The internal side (93) of the watch case (90) also differs from the base element (81) in that it comprises a region (95), for example a substantially rectangular region (95) centrally disposed. The region (95) has slightly raised edges in order to better allow the watch band to be inserted within the assembly (89). The region (95) could also be slightly recessed with respect to the remaining part of the internal side (93). The region (95) substantially corresponds to the region (203) of the base element (81) previously discussed in Figure 43. Region (95) may have different shapes matching the shape of the item to be inserted in the hinging assembly. When the item is a strap including a substantially oval portion matching the oval shape of a watchcase, the region (95) has preferably a substantially oval shape.

[0101] Figure 44B shows a further embodiment of the hinging assembly (89), wherein the watch case (90) does not include a region such as region (95) of Figure 44A and the base element (81) includes the region (203) already described with reference to Figure 43. In this embodiment, the region (203) is recessed with respect to the remaining part of the internal side of the base element (81), has a substantially oval shape, and no slightly raised edges. The side portions (83,84) are bent along upper edges (204,205) and lower edges (206,207) to allow a better grasping of the watch band to be hosted in the region (203).

[0102] Figures 45A and 45B show the hinging assembly (89) in an open condition hosting a watch band (96). Figure 45A shows a first embodiment, where the hinging assembly according to the embodiment of Figure 44A is employed, and where the watch band (96) is a strap having a substantially rectangular portion in the portion matching with region (95). Figure 45B shows a further embodiment, where a hinging assembly substantially similar to the hinging assembly according to the embodiment of Figure 44B is employed, and where the watch band is a strap having a central substantially oval portion (201). The oval portion (201) matches with an oval embodiment (202) of the region (95). The oval portion (201) lies on the region (203) in the base element.

[0103] Figures 46 and 47, show other uses of the hinging assembly (89), where the overall shape of the watch band is different from the shape of the watch band (96) of Figure 45 or where supports different from a watch band are used, such as the support (97) of Figure 47. The support (97) also shows an upper hollow region (98) to allow the support to be attached to other items. The portion of support (97) hosted in the hinging assembly

may have other shapes, in particular a substantially circular oval shape matching the shape of the region (95) in the watchcase and/or region (203) in the base element.

[0104] The person skilled in the art will understand, upon reading of the present disclosure, that the base element (81) of Figures 43-45 can be replaced by the leaf spring element exemplarily shown in Figures 33-37. On the other hand, the person skilled in the art will also understand, upon reading of the present disclosure, that the leaf spring element, such as the leaf spring element of Figure 27, can be replaced by the base element (81) exemplarily shown in Figure 43-45.

[0105] Both the hinge mechanism used to hingedly connect the elements of the hinging assembly of the disclosure and the locking mechanism used to secure the elements of the hinging assembly of the disclosure are known as such to the person skilled in the art and will not be described in detail.

6. System and method to teach how to tell time

[0106] The present disclosure also provides a watch system and method to teach a user how to tell the time, particularly useful for users having difficulties in learning the concept of time, such as children and persons with learning disabilities.

[0107] The watch system includes a first display showing the time in an analog or digital manner and a second display showing indication of an event associated with the time shown by the first display. The configuration and dimensions of the first and second display may vary and differ in complexity. The system may also emit sounds accompanied with the indications shown by means of a sound-emitting assembly.

[0108] Figure 48 and the enlarged portion of Figure 48 shown in Figure 49 show a "first level" system where the first display (99) shows a plurality of hour hands (150) and the second display (100) shows a picture or icon that relates to a specific time of day, e.g., sun rising, snack time, nap time, play time, bed time, moon. The picture or icon shown on the second display (100) relates to events in a child's day that are events/milestones in the child's day, thus helping the child to grasp time by tying it to such events/milestones. Preferably, the system is assembled according to one of the embodiments previously discussed. When the second display (100) shows a specific icon, such as a sun rising, the other icons not shown on the display (100) may either be hidden from or visible to the user. In case the other icons are hidden from the user, an opaque cover 160 may be provided. In case the other icons are not hidden from the user, a cover (160) is not necessary, or if provided, it may be transparent.

[0109] Figure 50 and the enlarged portion of Figure 50 shown in Figure 51 show a "second level" system where also minutes and seconds are shown in one of the displays, for example a digital display such as display (101) of Figure 51. The other display (102) shows an icon (103) thematically associated with the time shown in the display

(101).

[0110] Figure 52 and the enlarged portion of Figure 52 shown in Figure 53 show a "third level" system where one of the displays shows the time, for example in an analog manner as indicated by display (104) and the other display (105) shows an area for different modes that may include information thematically related with the time shown in display (104) and variable according to the skill of the user. The enlarged portions of the system of Figure 52, shown in Figure 53, are examples of multiple modes of the area shown in display (105) aiding a child in the learning and incorporating of time into the child's day.

[0111] For example, the enlargement (106) shows the area of the display (105) in an animation mode; the enlargement (107) shows the area of display (105) in an activity mode where the watch counts down a major event in a child's day, for example lunch time; in the enlargement (108), the area of display (105) is in a time quiz game mode; in the enlargement (109) the area of display (105) shows, in a digital format, a time relating to the time shown in display (104) in an analog format; and in the enlargement (110) the area of display (105) is in an alarm mode.

[0112] Additionally, sounds and animation may also be displayed in all of the embodiments of the system.

[0113] The system may be assembled to other items, and in particular to any watch band known in the art, possibly including the snap mechanism according to the present disclosure. The assembly may be made using a technology known in the art and identifiable by the person skilled in the art or by realizing a hinging assembly in accordance with the teachings of the present disclosure.

[0114] The relative size of the first and second display can vary. The first display can have a size which is greater than, less than or equal to the size of the second display.

[0115] In summary, a magnet assembly connectable to a metal assembly in an engaging fashion, a metal assembly connectable with the magnet assembly in an engaging fashion and a snapping mechanism comprising the magnet assembly and the metal assembly are disclosed, to be used with a strap and a watch case. A leaf spring element and a base element to be used with a watch case are also disclosed, together with manufacturing processes and a system and method to teach the concept of time.

[0116] The present disclosure has been explained with reference to specific embodiments. Other embodiments will be apparent to those of ordinary skill in the art in view of the foregoing description. The scope of protection of the present disclosure is defined by the appended claims.

Claims

1. A leaf spring element (39) having a first lateral portion (40), a second lateral portion (41) and a central portion (42) acting as a spring and located between the first lateral portion and the second lateral portion,

each of the first and second lateral portions having a substantially rectangular shape and comprising a slanted leg (59, 60), each slanted leg comprising a first leg portion and a second leg portion, the first leg portion substantially lying in a first plane, the second leg portion substantially lying on a second plane different from the first plane, the second leg portion ending with a hollow section (63, 64), each of the first and second lateral portions comprising a first corner (52, 53) substantially facing the central portion; the central portion being a bent central portion having a substantially trapezoidal shape with a first slanted edge (44) and a second slanted edge (45); the leaf spring element further comprising first and second cut sections (46, 47) separating the central portion from the first and second lateral portions respectively, each of the first and second cut sections having a distal end (48, 49) and a proximate end (50, 51), the distal end being located between the first or second slanted edge and the first corner of the first and second lateral portions.

2. The leaf spring element of claim 1, wherein the second plane is substantially perpendicular to the first plane.
3. The leaf spring element of claim 1 or claim 2, wherein each of the first and second lateral portions comprises a second corner and a third corner, distal to the central portion, each of the first and second lateral portions comprising a first tooth (71) located adjacent the second corner and a second tooth (71) located adjacent to the third corner, the first and second teeth located in a third plane and the first and second lateral portions located in a fourth plane different from the third plane.
4. The leaf spring element of claim 3, wherein the third plane is substantially perpendicular to the fourth plane.

Patentansprüche

1. Blattfederelement (39) mit einem ersten seitlichen Abschnitt (40), einem zweiten seitlichen Abschnitt (41) und einem mittleren Abschnitt (42), der als Feder fungiert und sich zwischen dem ersten seitlichen Abschnitt und dem zweiten seitlichen Abschnitt befindet, wobei jeder der ersten und zweiten seitlichen Abschnitte eine im Wesentlichen rechteckige Form und ein abgeschrägtes Bein (59, 60) aufweist, wobei jedes abgeschrägte Bein einen ersten Beinabschnitt und einen zweiten Beinabschnitt aufweist, wobei der erste Beinabschnitt im Wesentlichen in einer ersten Ebene liegt, wobei der zweite Beinabschnitt im Wesentlichen auf einer zweiten Ebene liegt, die sich von der ersten Ebene unterscheidet, wobei der zweite

Beinabschnitt mit einem Hohlbereich (63, 64) abschließt;

wobei jeder der ersten und zweiten seitlichen Abschnitte eine erste Ecke (52, 53) aufweist, die im Wesentlichen dem mittleren Abschnitt zugewandt ist; wobei der mittlere Abschnitt ein gebogener mittlerer Abschnitt ist, der im Wesentlichen eine Trapezform mit einer ersten abgeschrägten Kante (44) und einer zweiten abgeschrägten Kante (45) aufweist; wobei das Blattfederelement ferner erste und zweite ausgeschnittene Bereiche (46, 47) aufweist, die den mittleren Abschnitt jeweils von dem ersten und dem zweiten seitlichen Abschnitt trennen, wobei jeder der ersten und zweiten ausgeschnittenen Bereiche ein distales Ende (48, 49) und ein proximales Ende (50, 51) aufweist, wobei sich das distale Ende zwischen der ersten oder zweiten abgeschrägten Kante und der ersten Ecke des ersten oder zweiten seitlichen Abschnitts befindet.

2. Blattfederelement nach Anspruch 1, wobei die zweite Ebene im Wesentlichen senkrecht zur ersten Ebene ist.
3. Blattfederelement nach Anspruch 1 oder 2, wobei jeder der ersten oder zweiten seitlichen Abschnitte eine zweite Ecke und eine dritte Ecke aufweist, distal zu dem mittleren Abschnitt, wobei jeder der ersten und zweiten seitlichen Abschnitte eine erste Zahn (71) aufweist, der sich benachbart zu der zweiten Ecke befindet, und einen zweiten Zahn (71) aufweist, der sich benachbart zu der dritten Ecke befindet, wobei sich der erste und der zweite Zahn in einer dritten Ebene befinden und wobei sich die ersten und zweiten seitlichen Abschnitte in einer vierten Ebene befinden, die sich von der dritten Ebene unterscheidet.
4. Blattfederelement nach Anspruch 3, wobei die dritte Ebene im Wesentlichen senkrecht zur vierten Ebene ist.

64), chacune des première et deuxième parties latérales comprenant un premier coin (52, 53) faisant sensiblement face à la portion centrale; la partie centrale étant une partie centrale courbe ayant une forme sensiblement trapézoïdale avec un premier bord incliné (44) et un second bord incliné (45); l'élément de ressort à lame comprenant en outre des première et seconde sections coupées (46, 47) séparant la partie centrale respectivement des première et seconde parties latérales, chacune des première et seconde sections coupées ayant une extrémité distale (48, 49) et une extrémité proximale (50, 51), l'extrémité distale étant située entre le premier ou le second bord incliné et le premier coin des première et seconde parties latérales.

2. L'élément de ressort à lame selon la revendication 1, dans lequel le deuxième plan est sensiblement perpendiculaire au premier plan.
3. L'élément de ressort à lame selon la revendication 1 ou la revendication 2, dans lequel chacune des première et seconde parties latérales comprend un second coin et un troisième coin, en position distale par rapport à la partie centrale, chacune des première et seconde parties latérales comprenant une première dent (71) disposés de façon adjacente au deuxième coin et une deuxième dent (71) situés à proximité du troisième coin, les première et deuxième dents étant situées dans un troisième plan et les première et deuxième parties latérales étant situées dans un quatrième plan différent du troisième plan.
4. L'élément de ressort à lame selon la revendication 3, dans lequel le troisième plan est sensiblement perpendiculaire au quatrième plan.

Revendications

1. Un élément de ressort à lame (39) comportant une première partie latérale (40), une deuxième partie latérale (41) et une partie centrale (42) jouant le rôle d'un ressort et situé entre la première partie latérale et la deuxième partie latérale, chacune des première et seconde parties latérales ayant une forme sensiblement rectangulaire et comprenant une jambe inclinée (59, 60), chaque jambe inclinée comprenant une première partie de jambe et une seconde partie de jambe, la première partie de jambe s'étendant sensiblement dans un premier plan, la seconde partie de jambe reposant sensiblement dans un deuxième plan différent du premier plan, la deuxième partie de jambe se terminant par une section creuse (63,

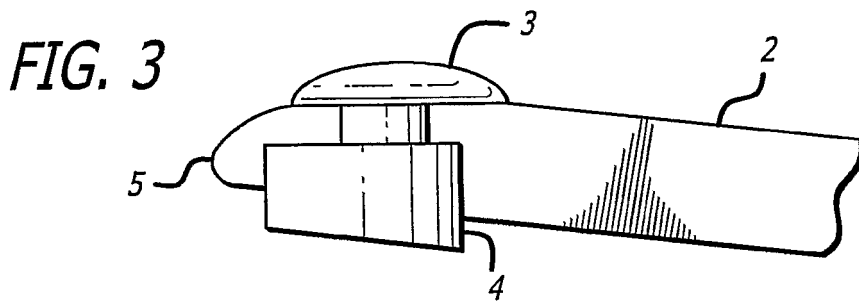
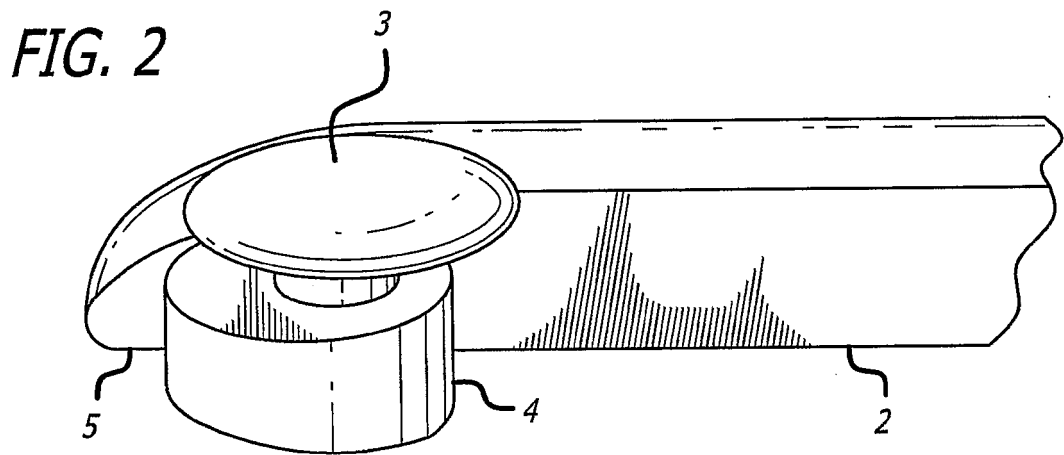
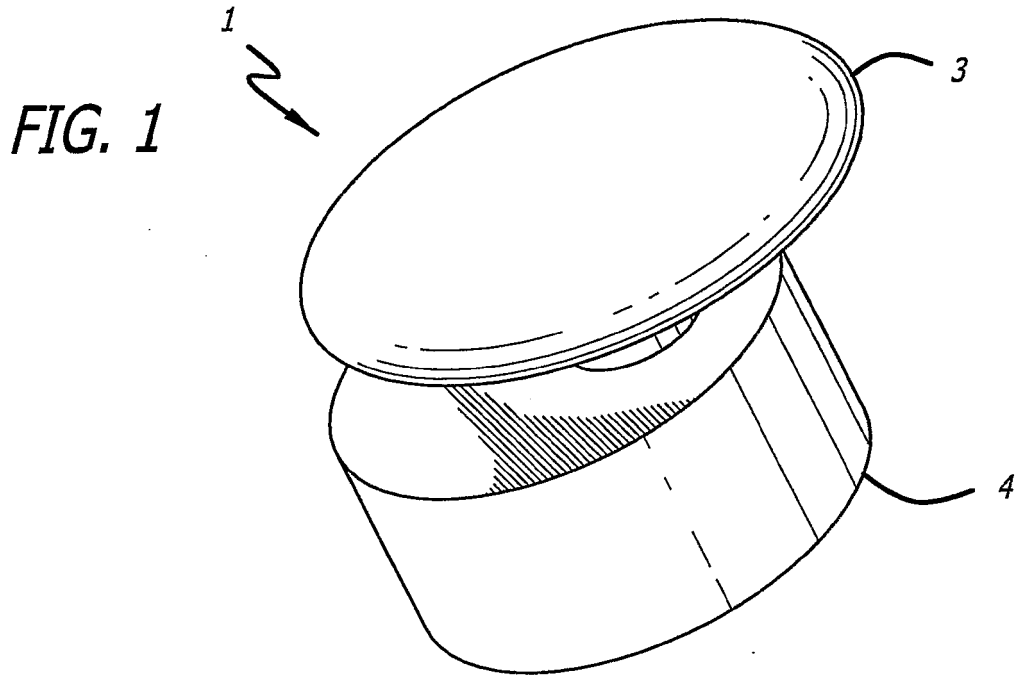

FIG. 4

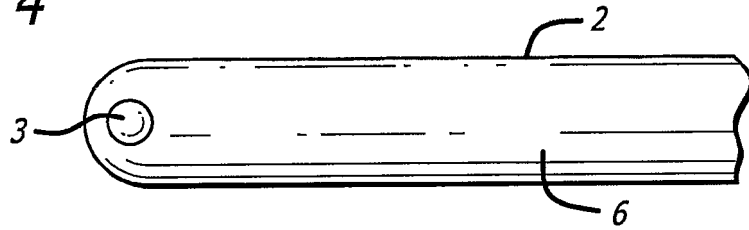

FIG. 5

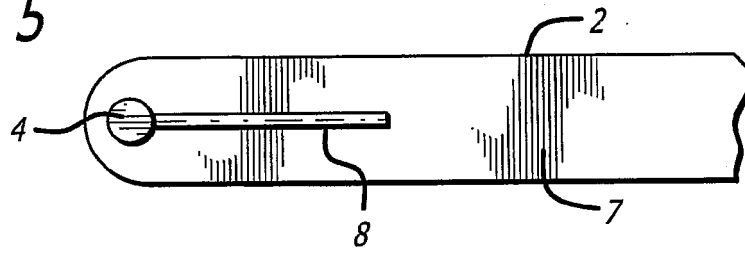

FIG. 6

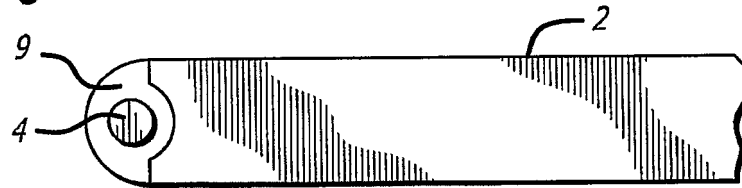

FIG. 7

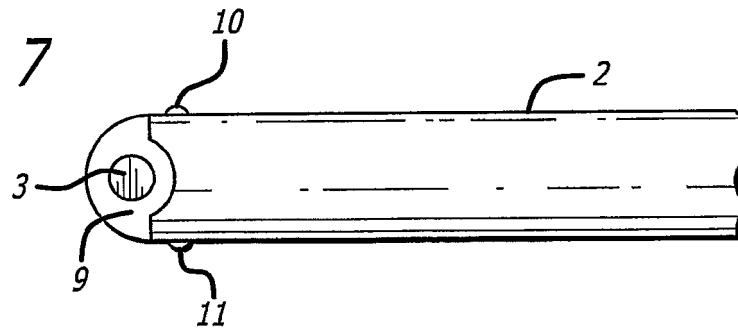
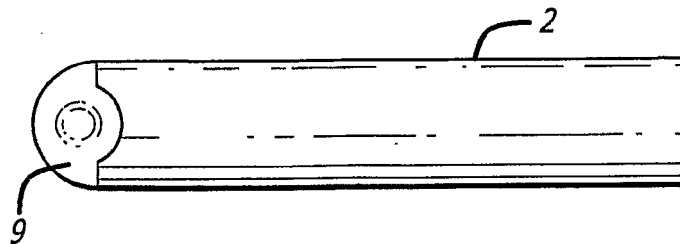

FIG. 8



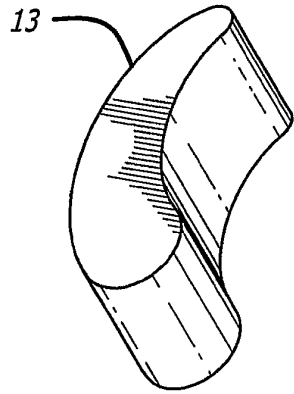
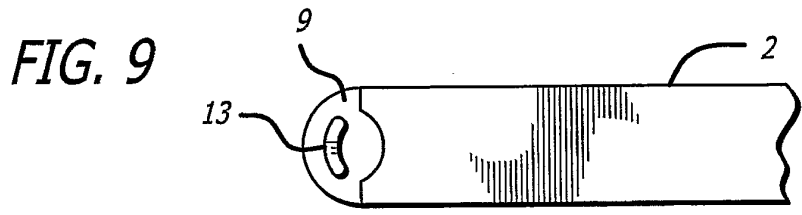

FIG. 10

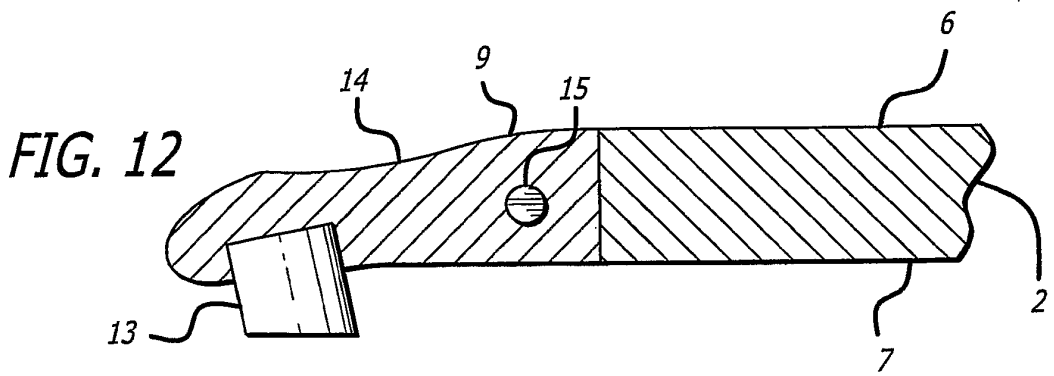
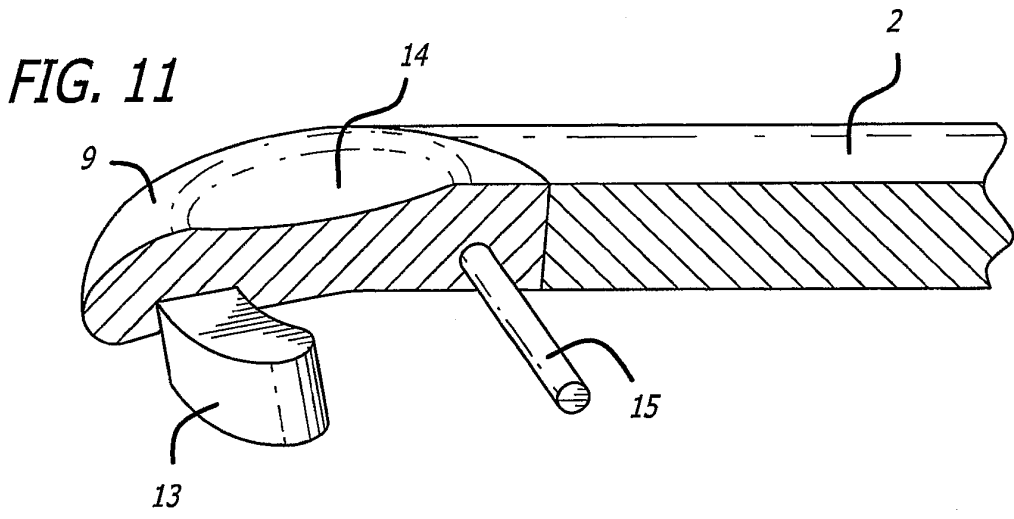

FIG. 13

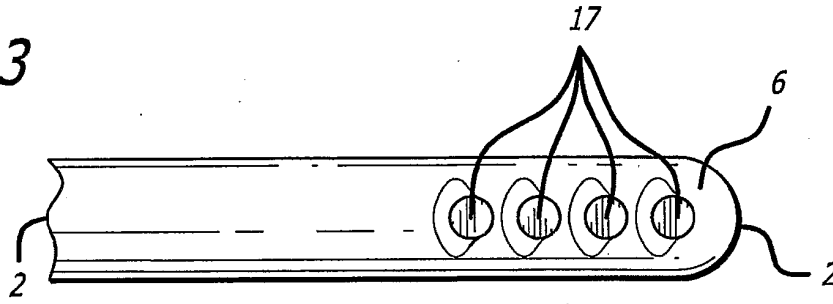

FIG. 14

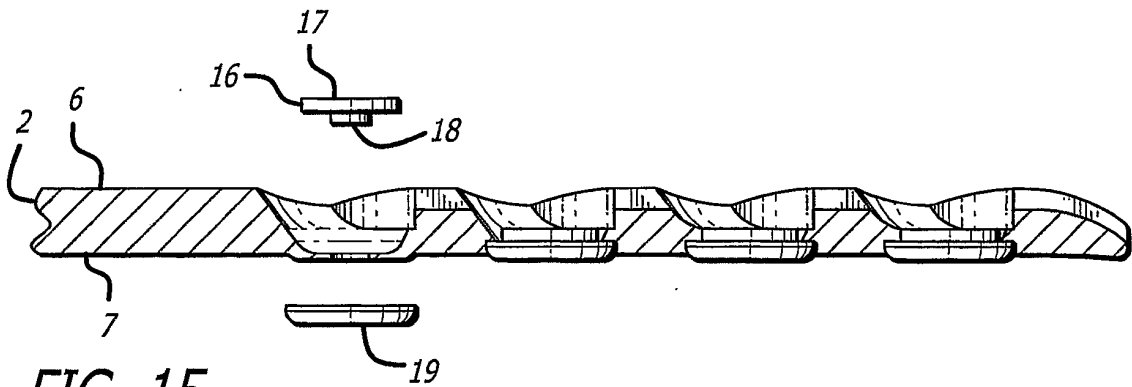
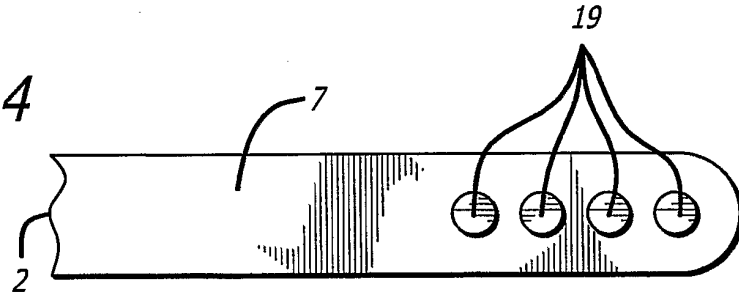

FIG. 15

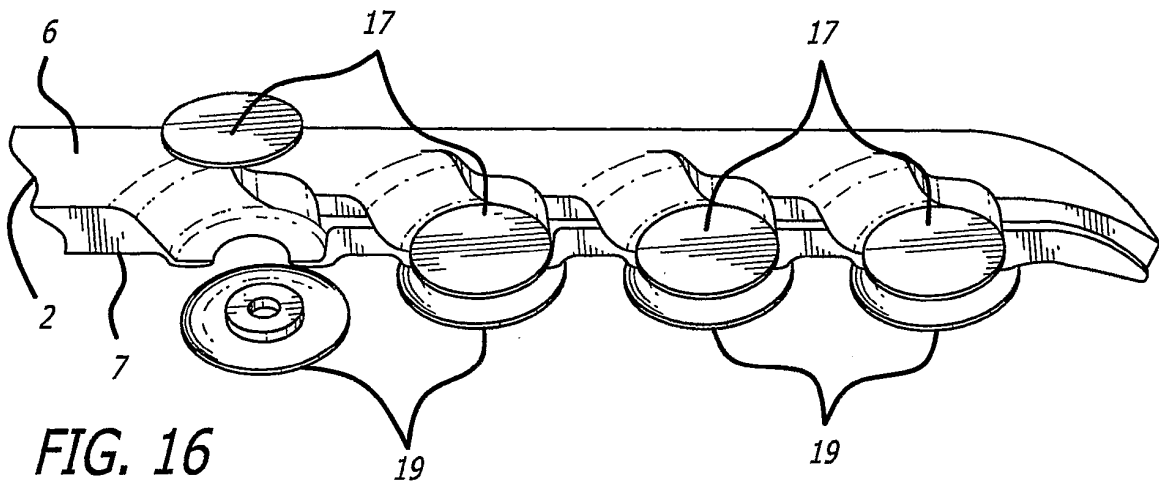

FIG. 16

FIG. 17

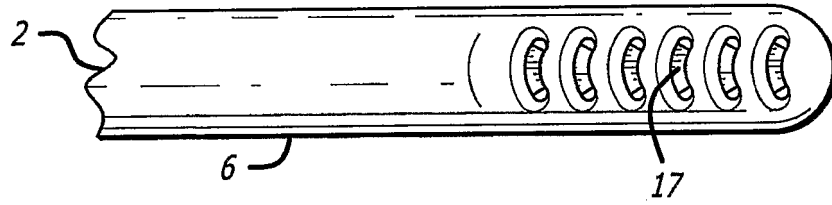

FIG. 18

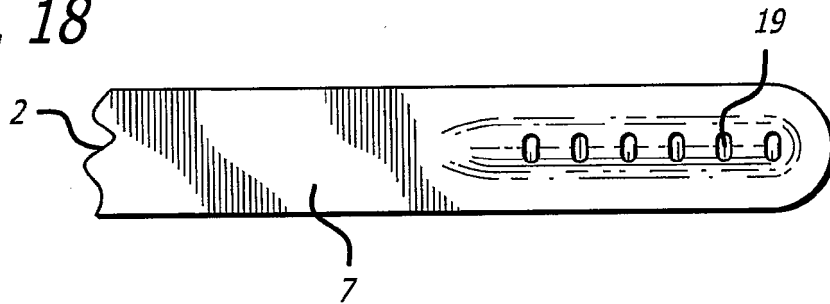

FIG. 19

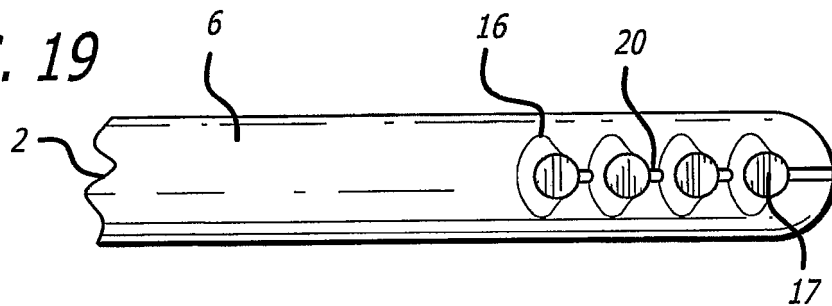
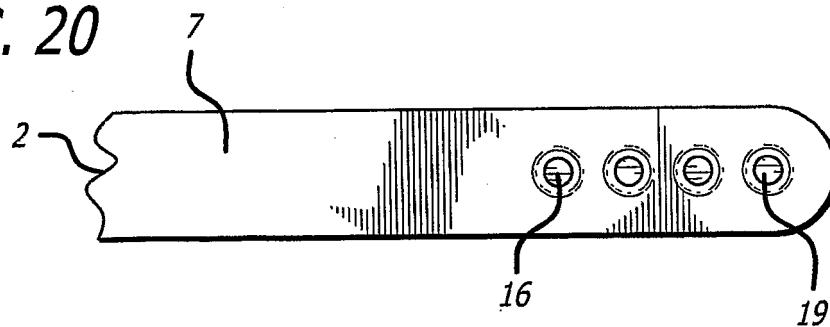

FIG. 20



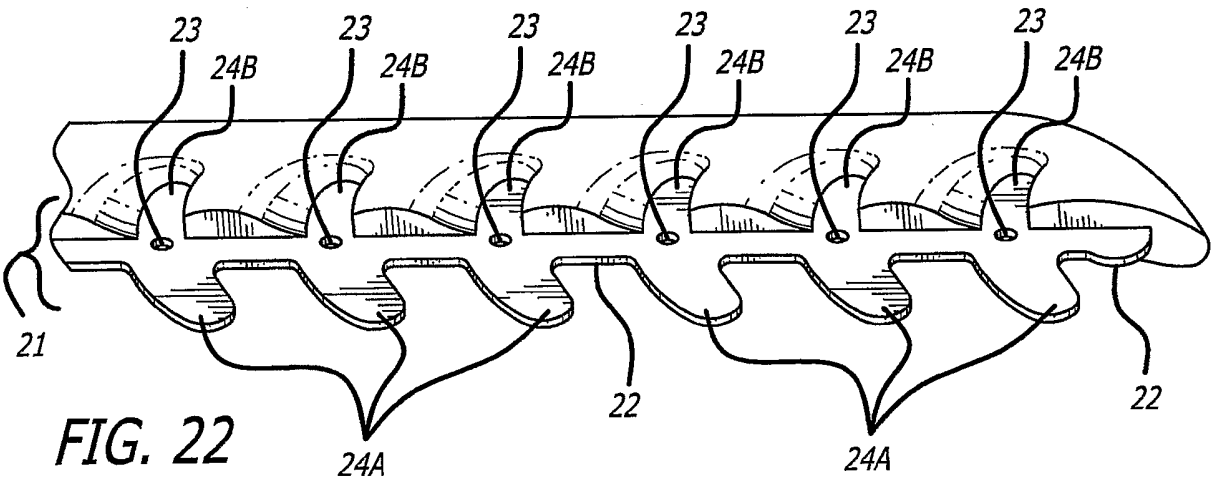
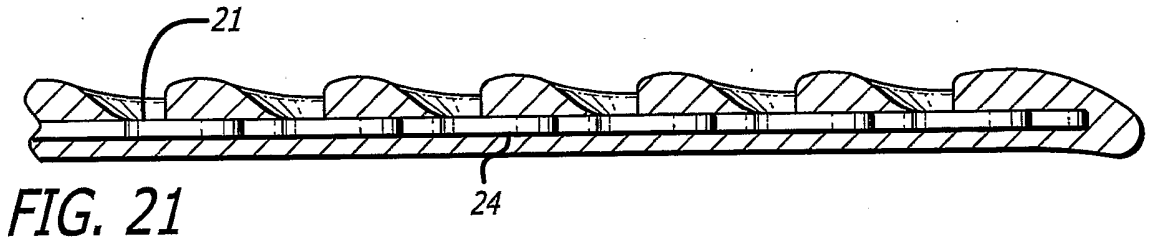
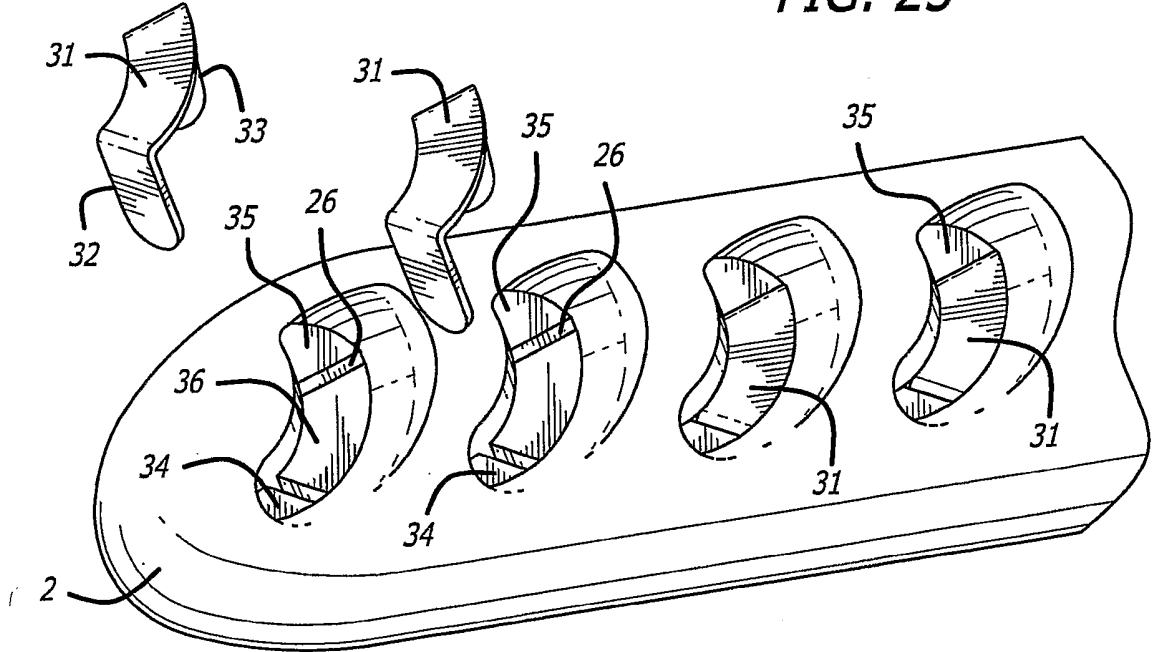
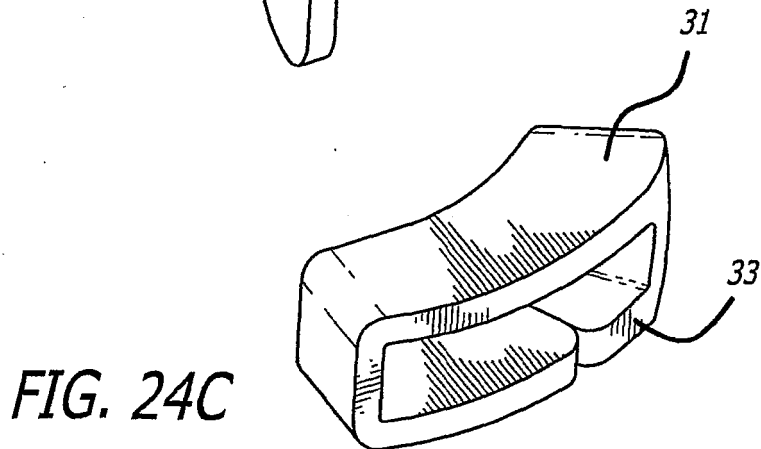
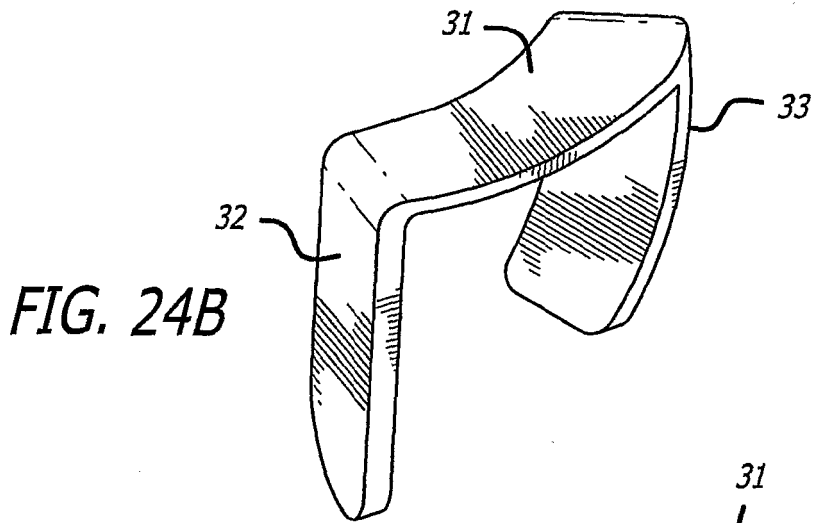
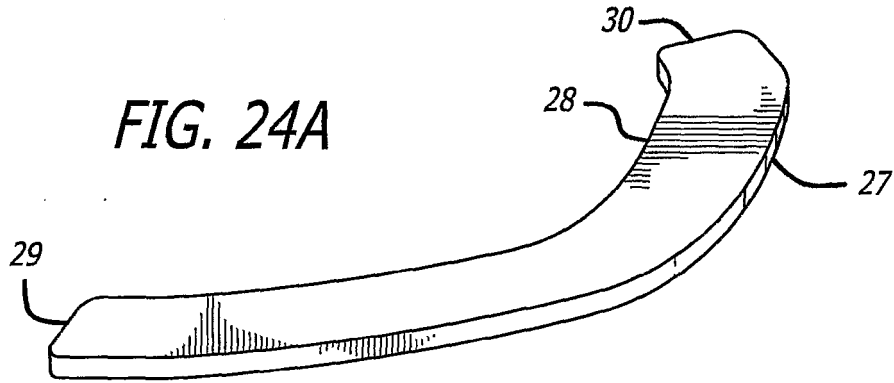
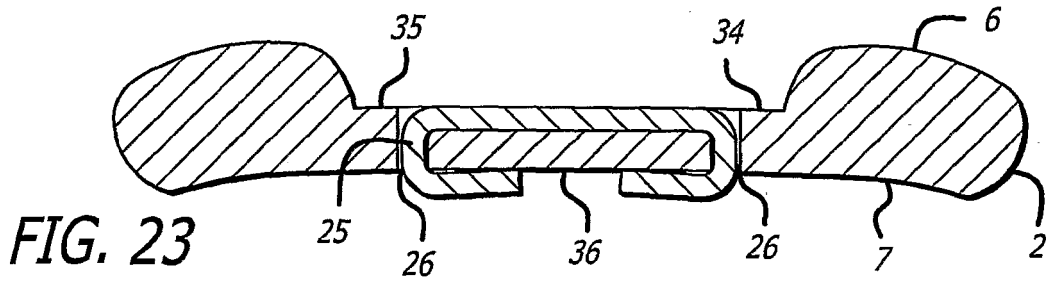

FIG. 22

FIG. 25





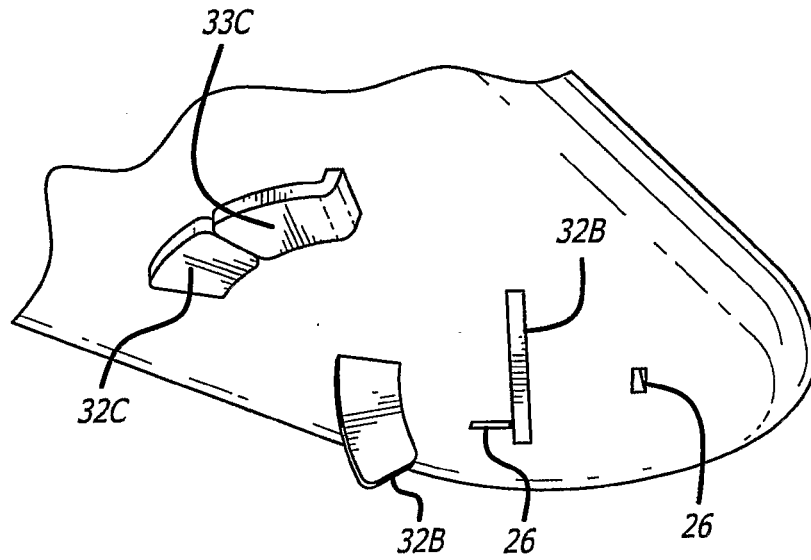

FIG. 26

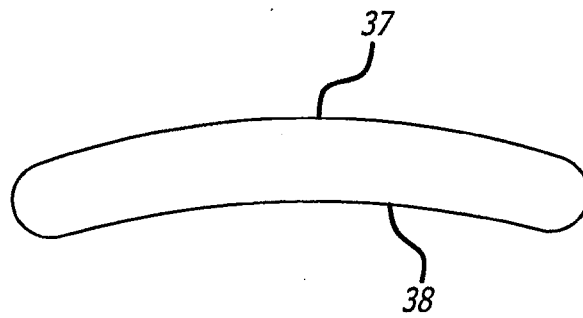

FIG. 27

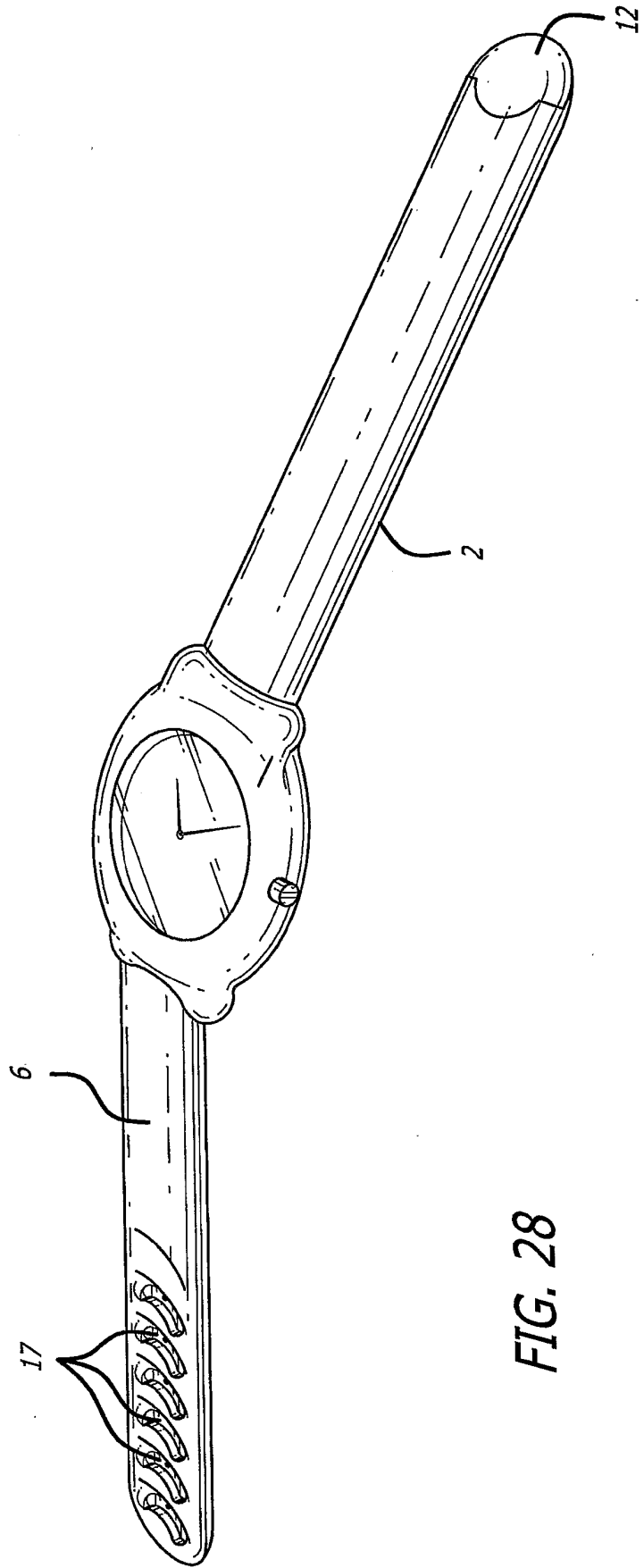

FIG. 28

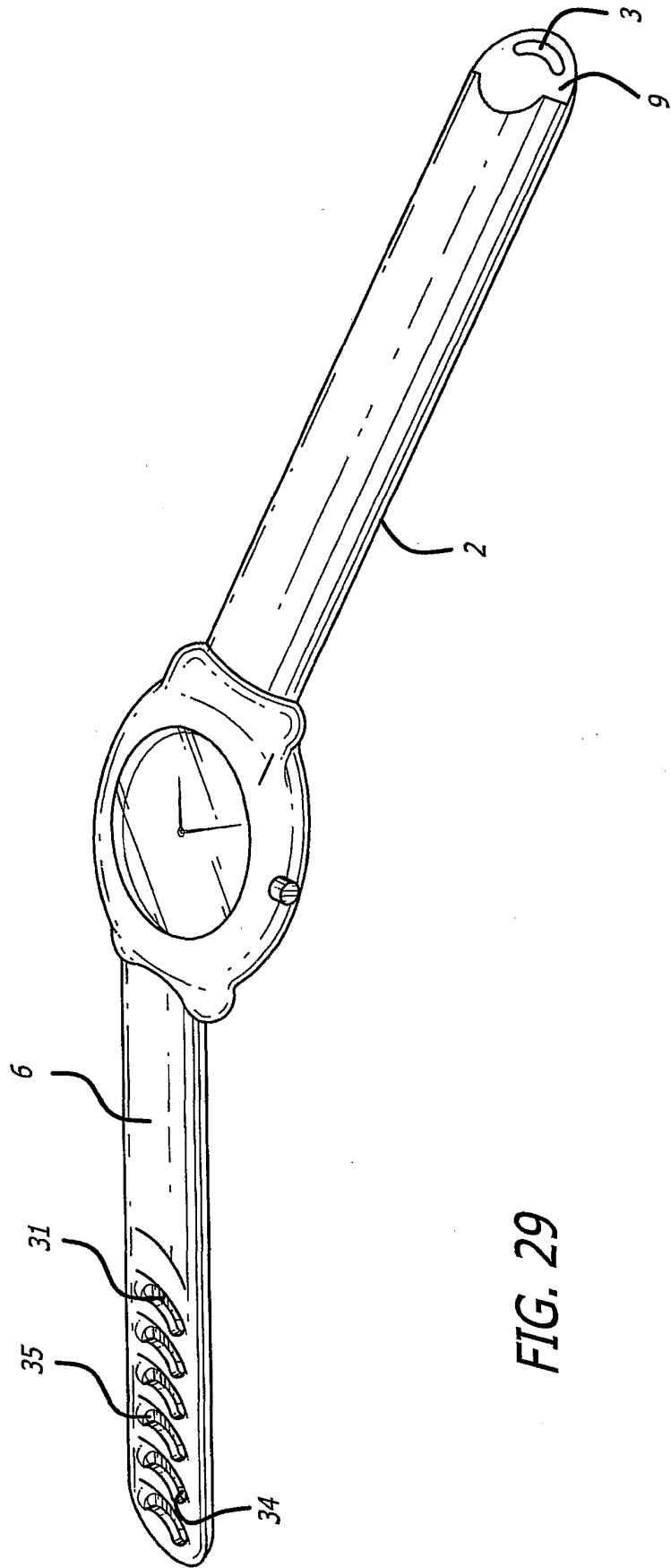
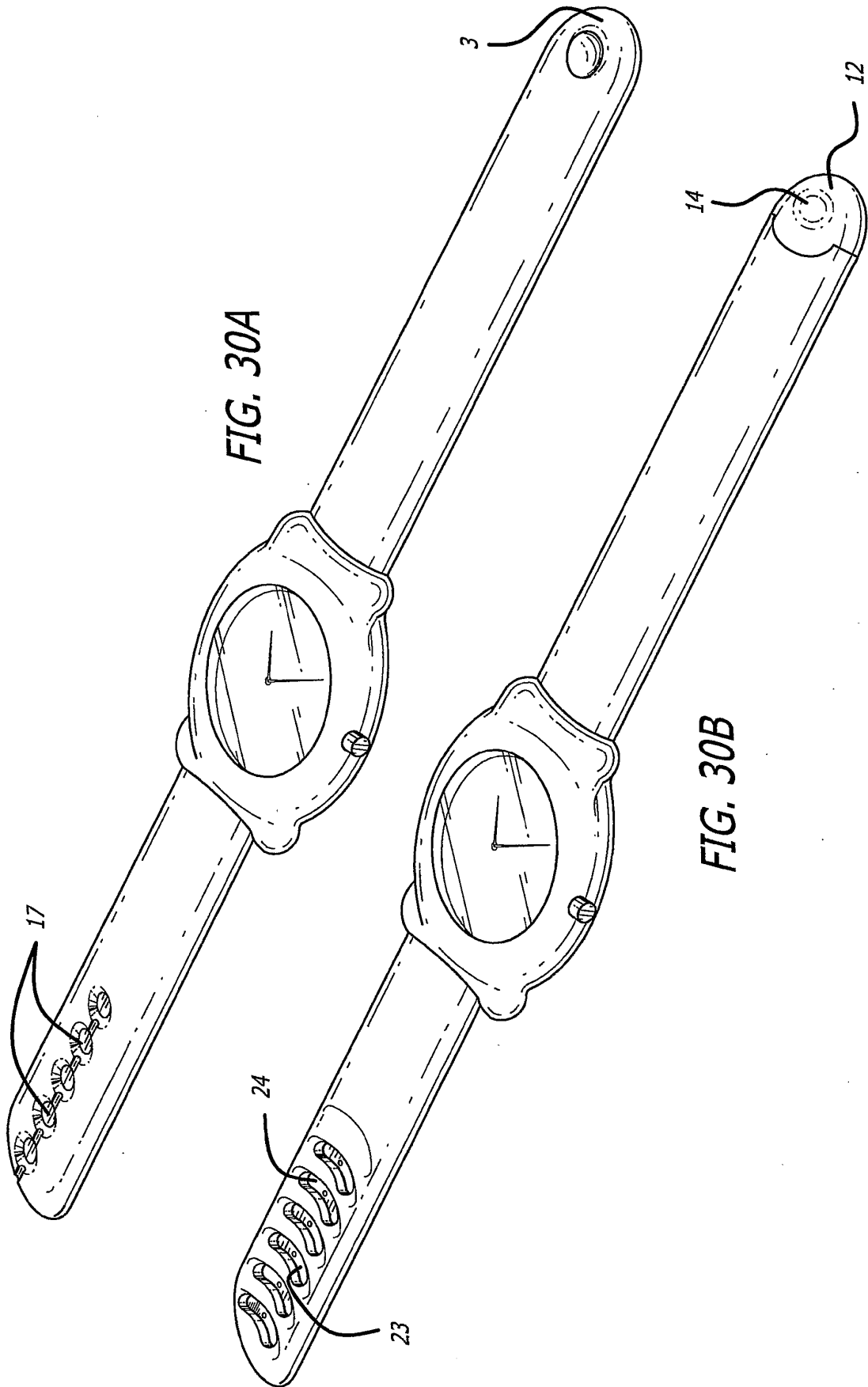

FIG. 29



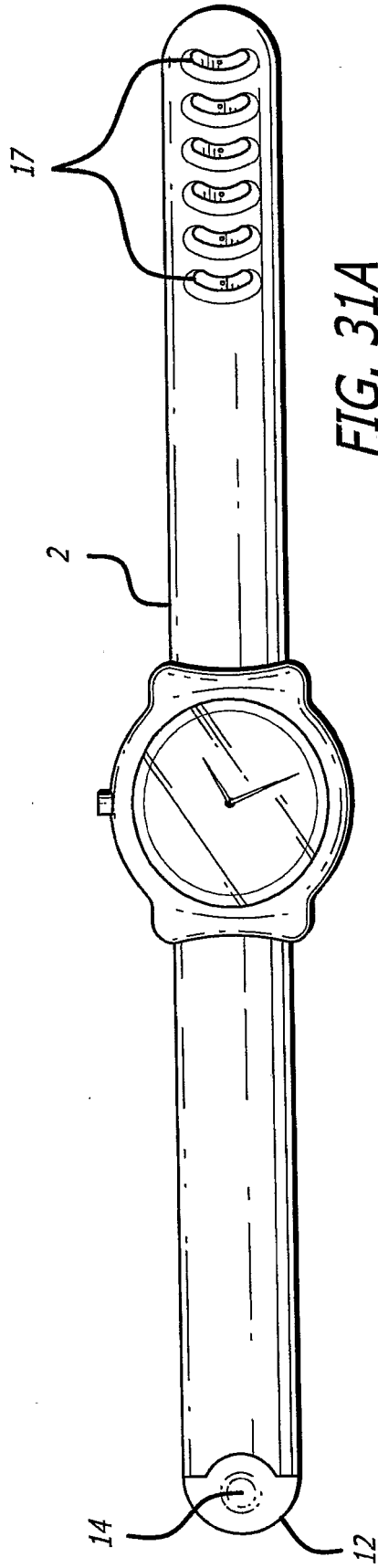

FIG. 31A

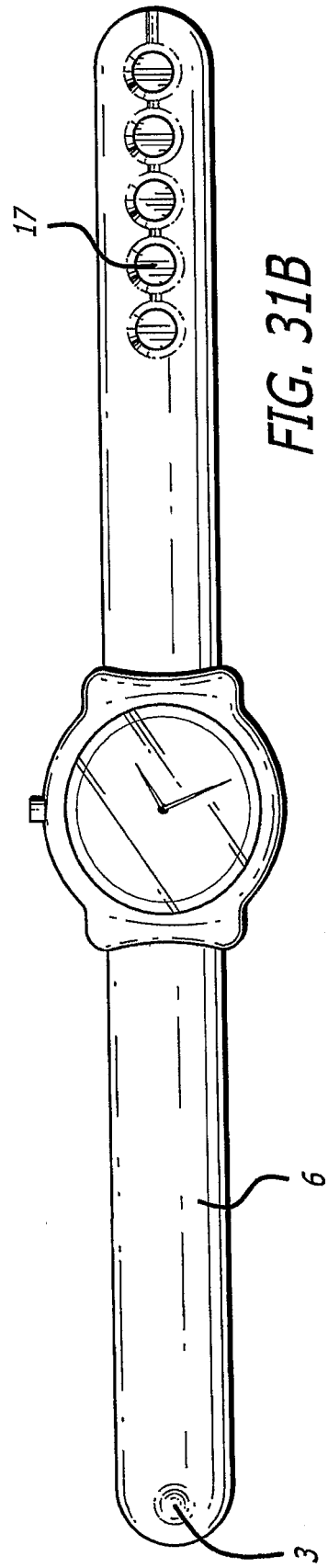
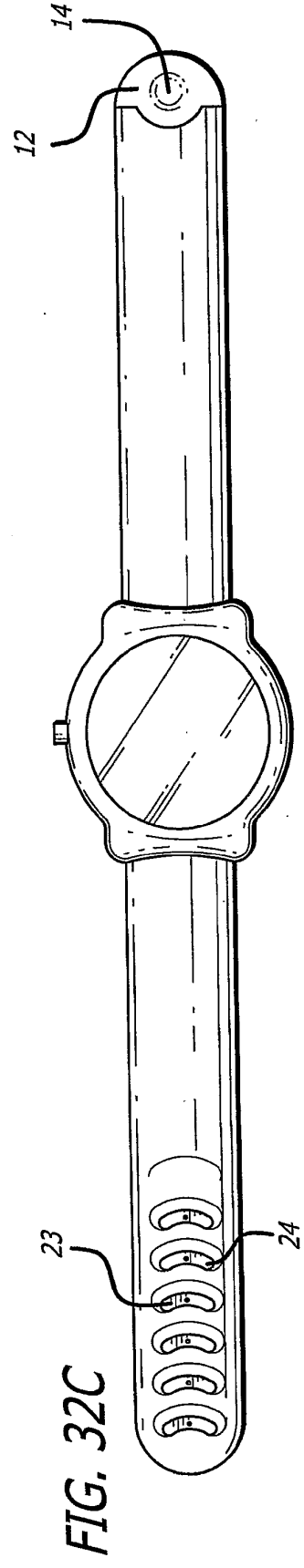
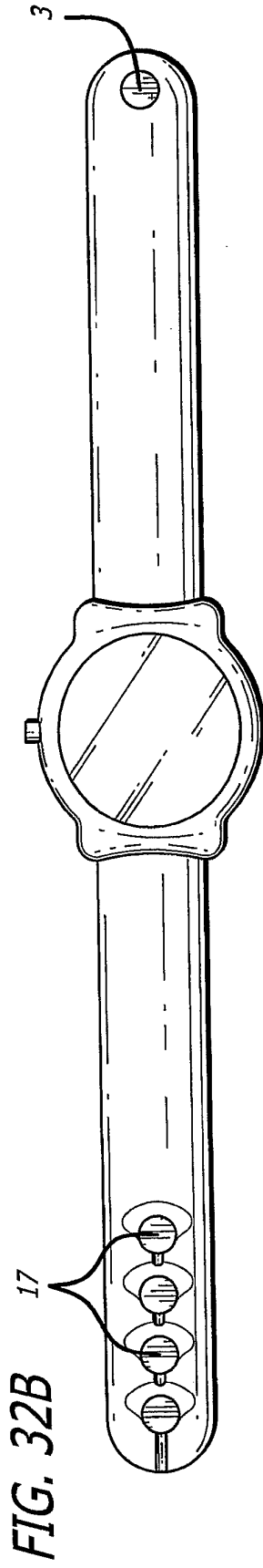
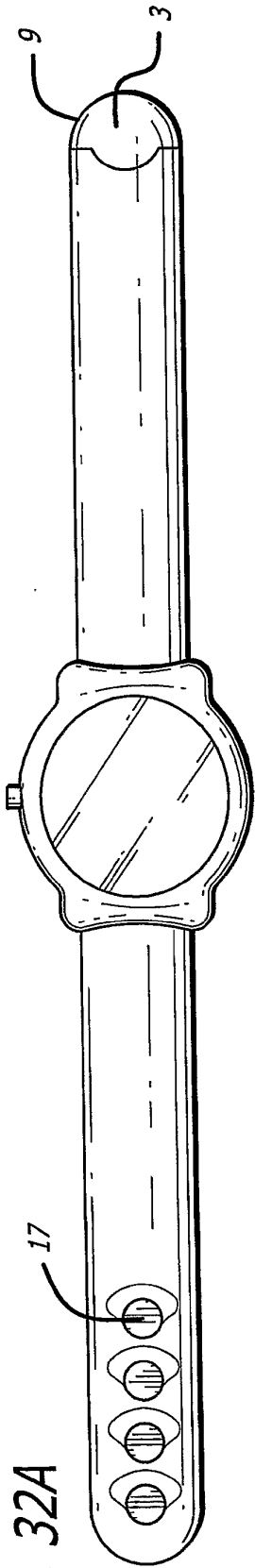

FIG. 31B



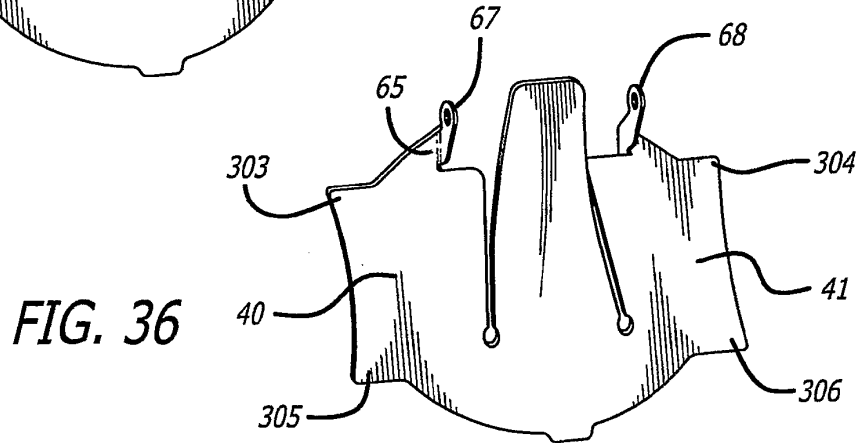
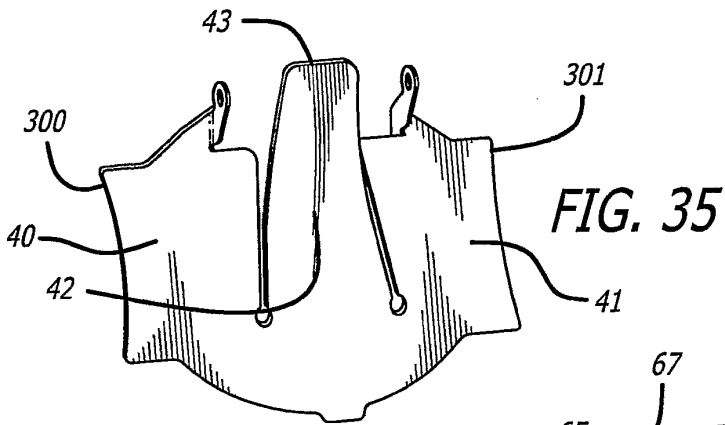
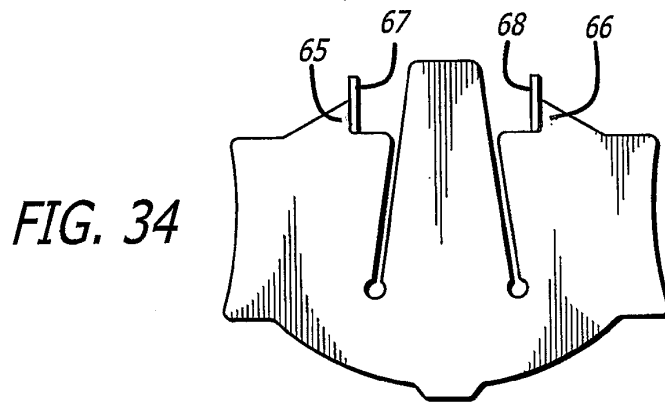
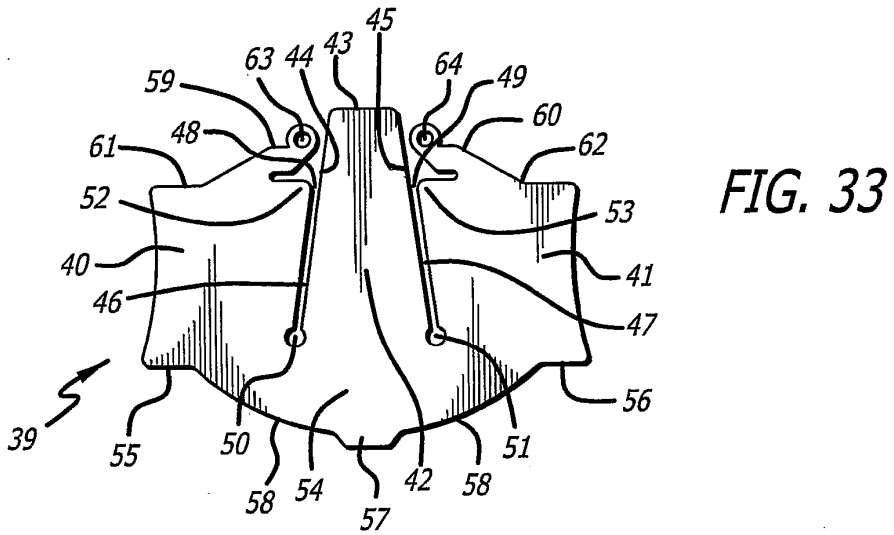

FIG. 37

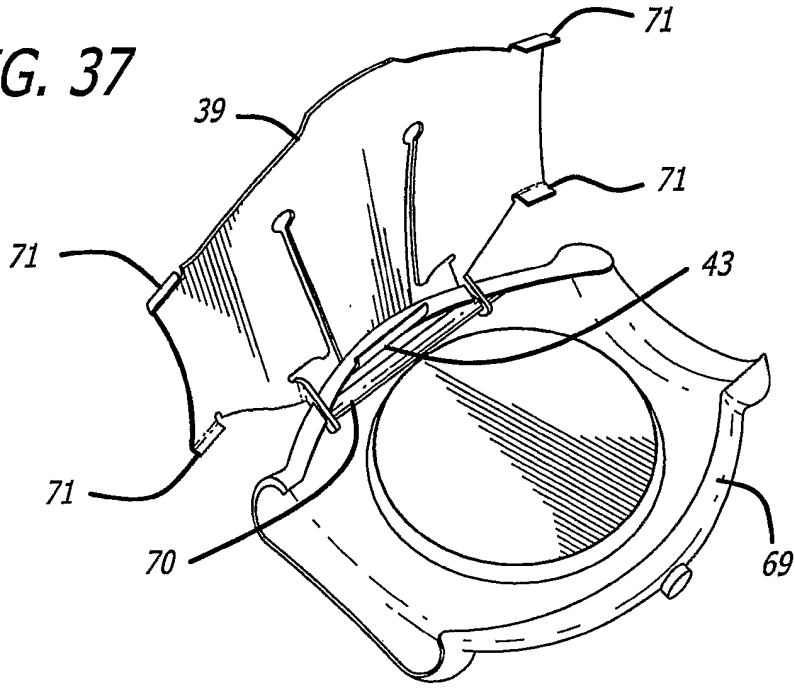

FIG. 38

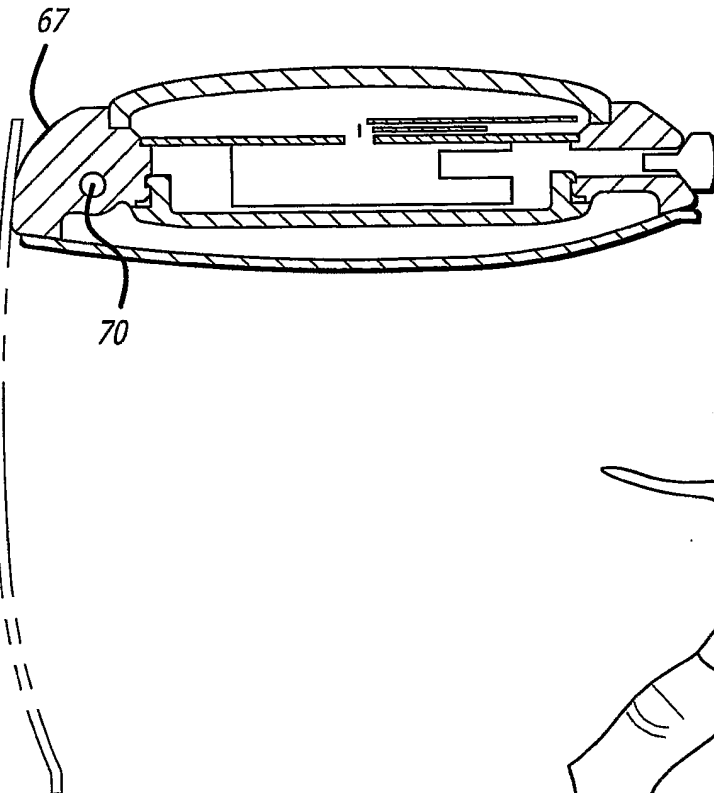
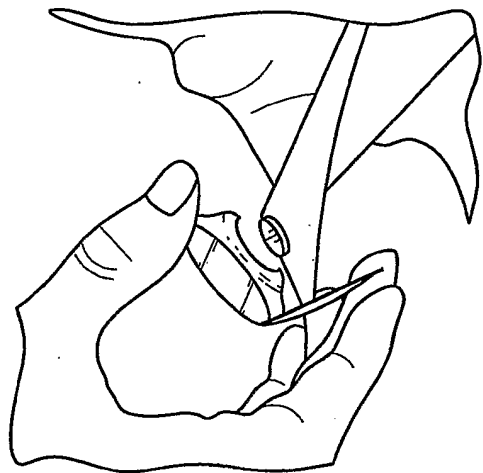

FIG. 39



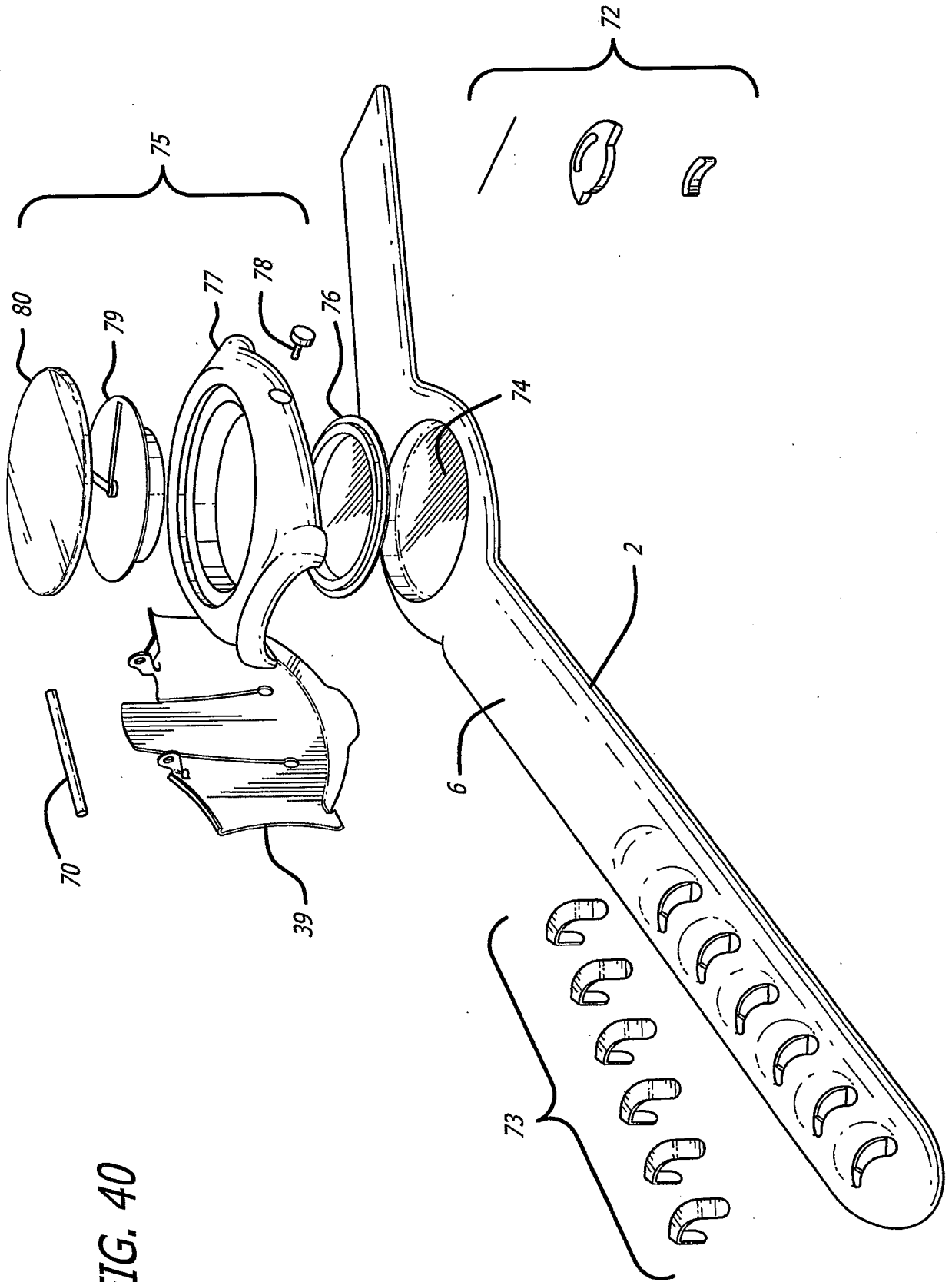

FIG. 40

FIG. 41

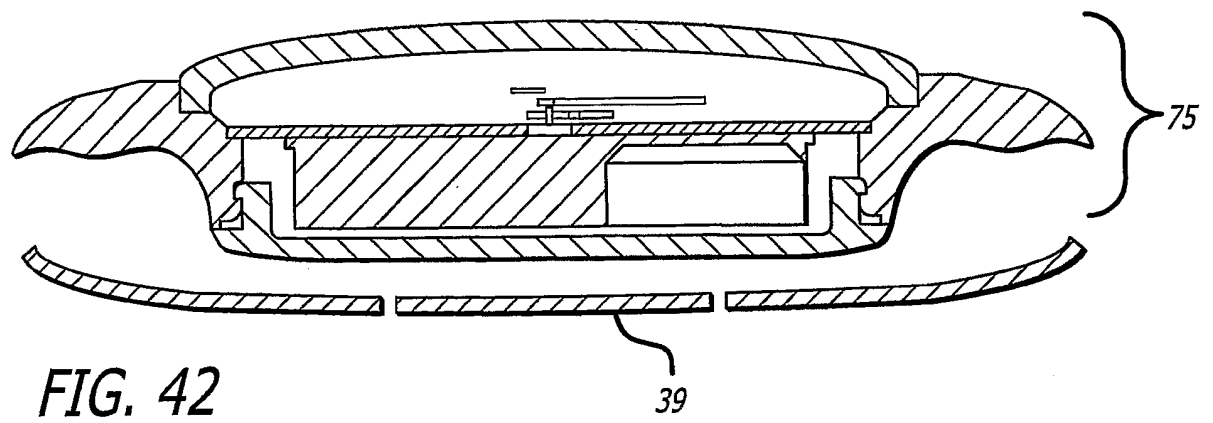
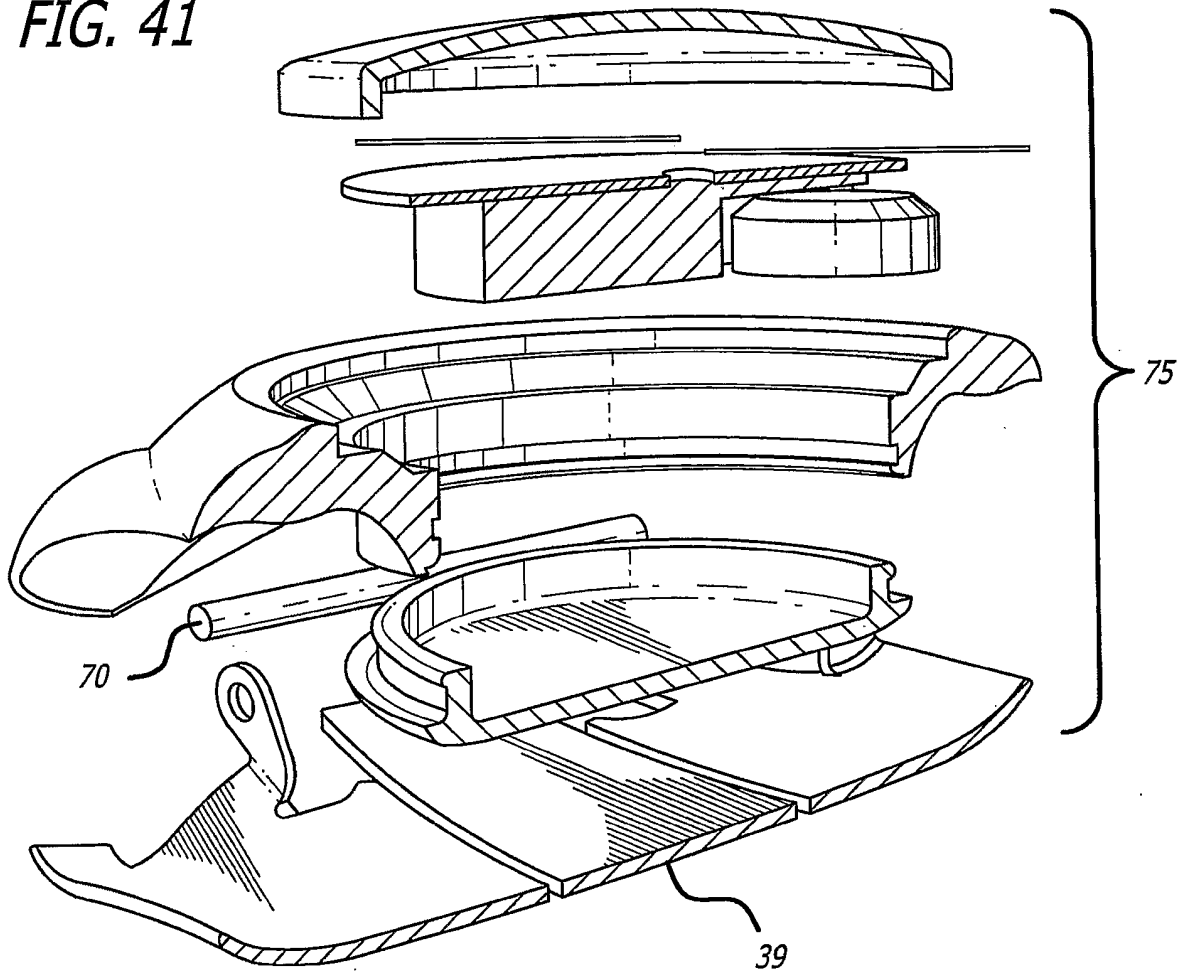

FIG. 42

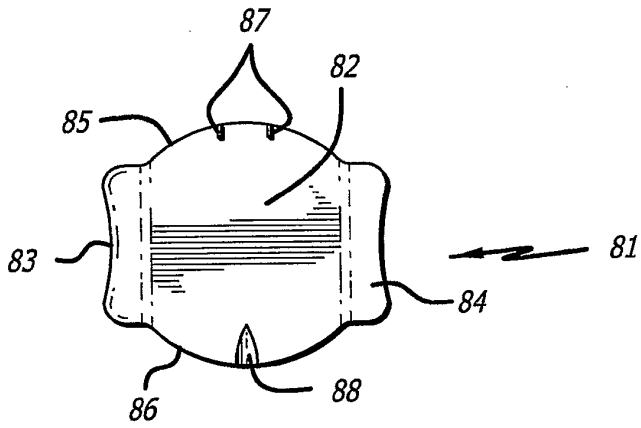

FIG. 43

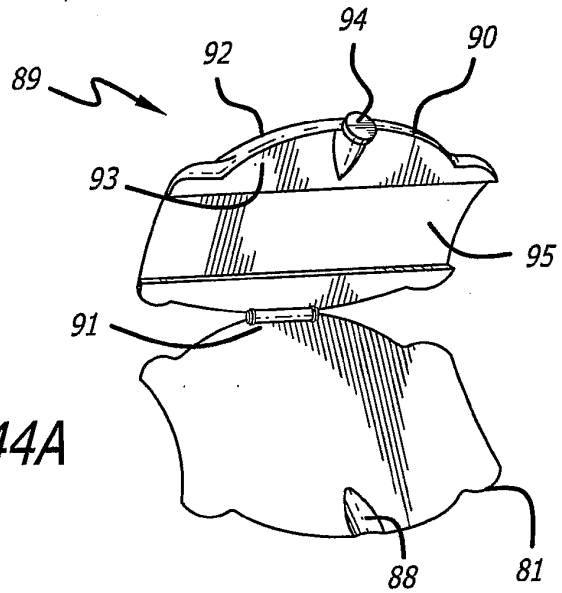

FIG. 44A

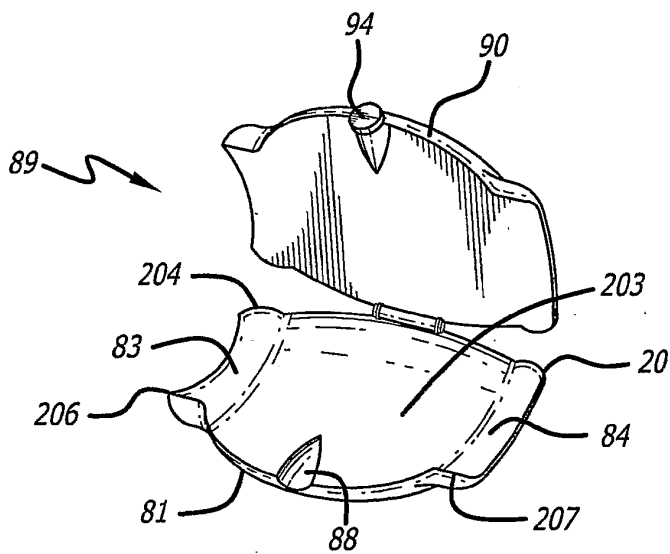

FIG. 44B

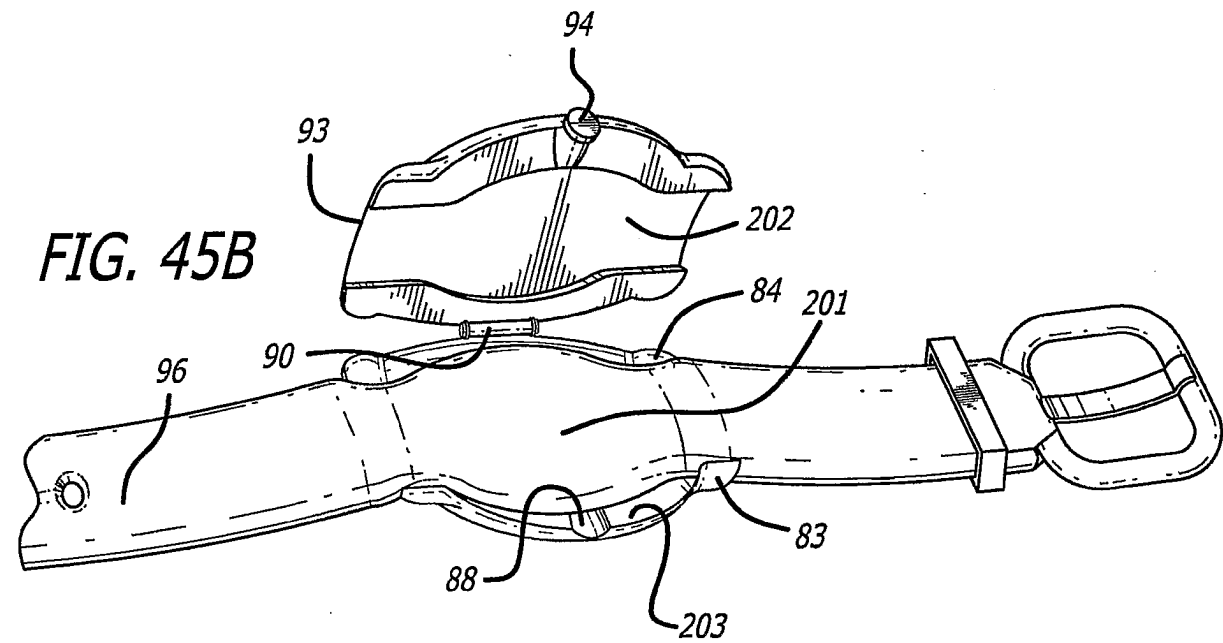
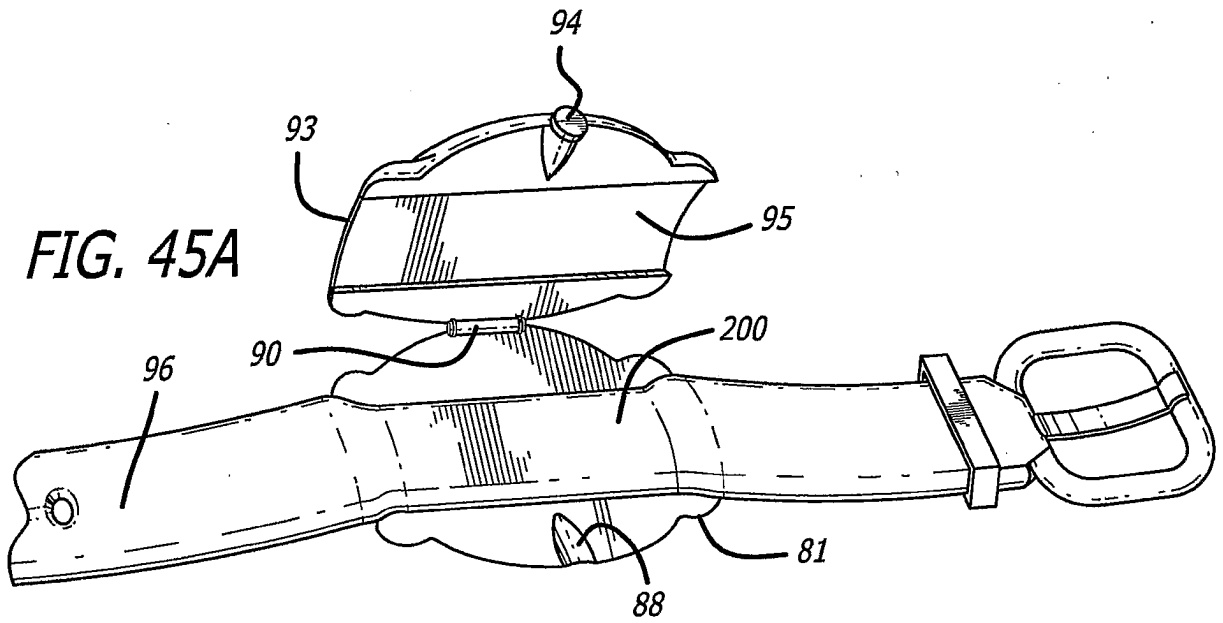

FIG. 46

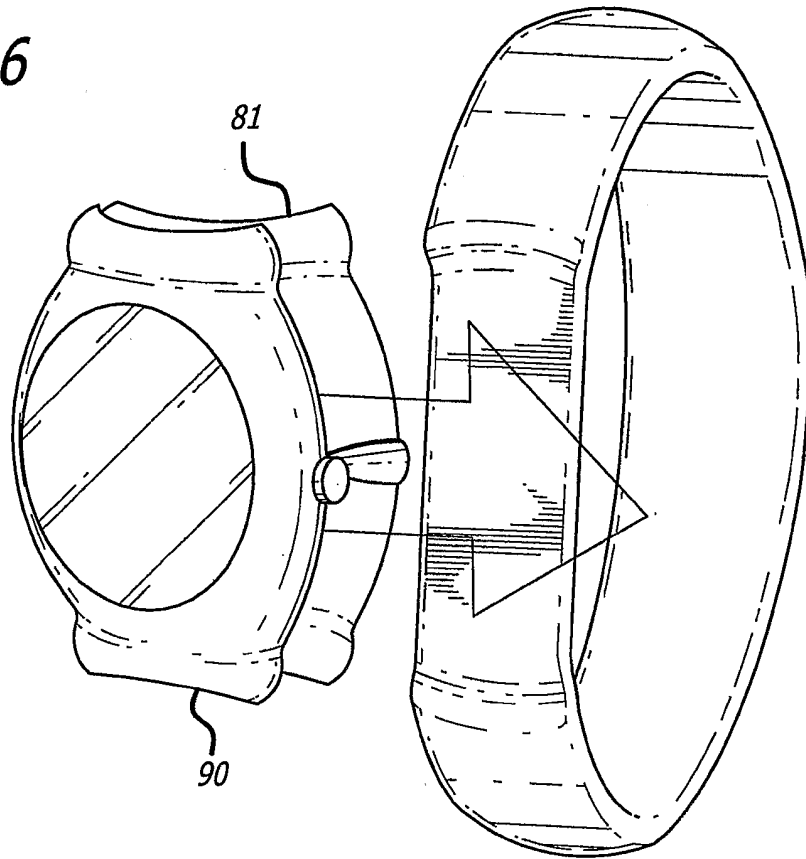
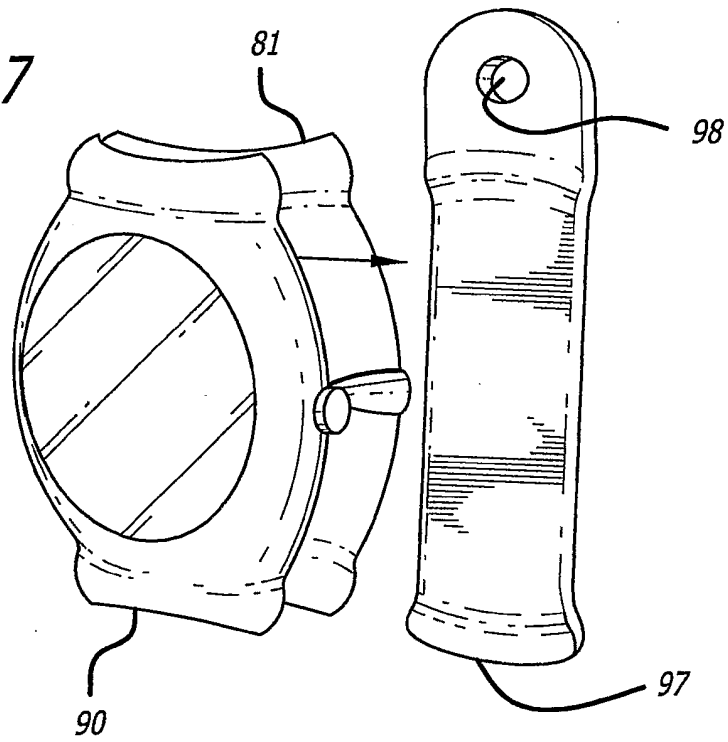

FIG. 47



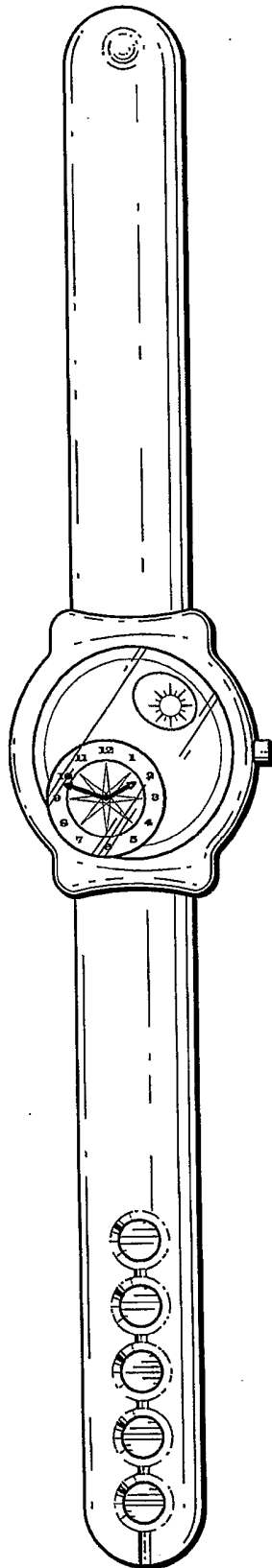

FIG. 48

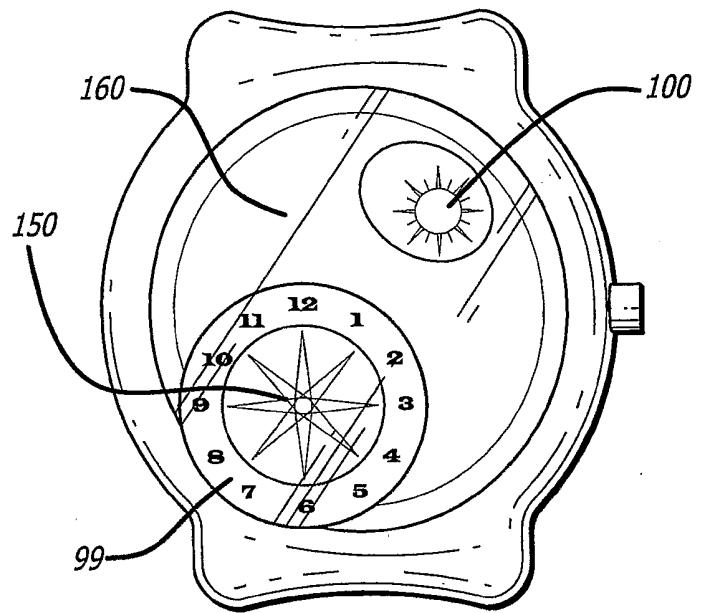

FIG. 49



FIG. 50

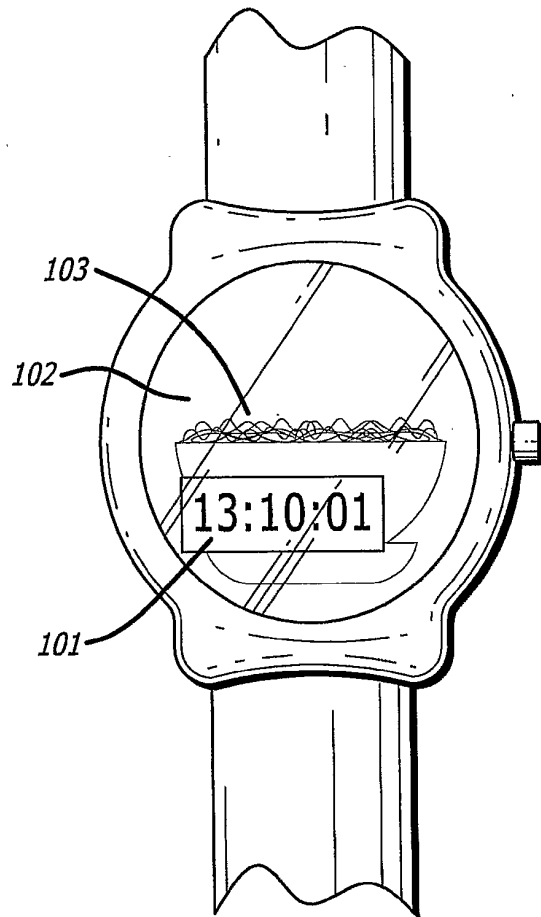

FIG. 51

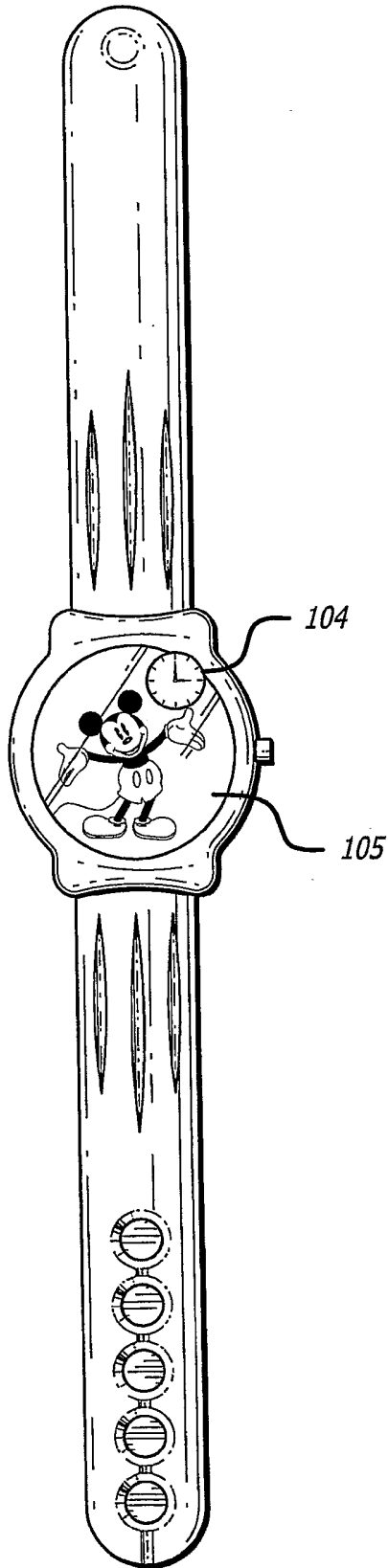

FIG. 52

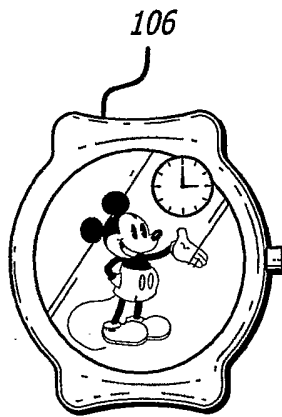

FIG. 53A

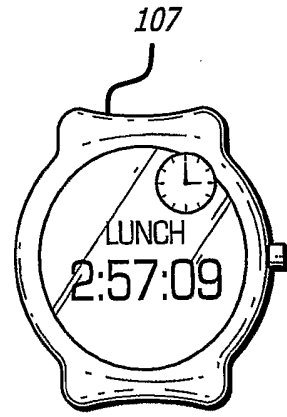

FIG. 53B

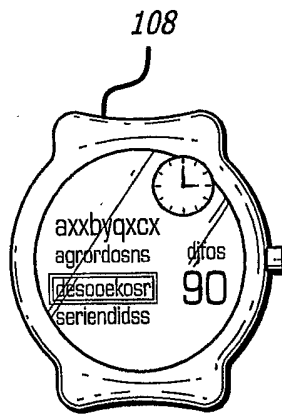

FIG. 53C

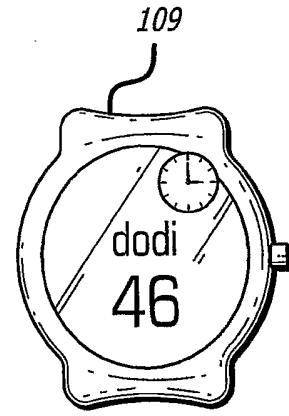

FIG. 53D

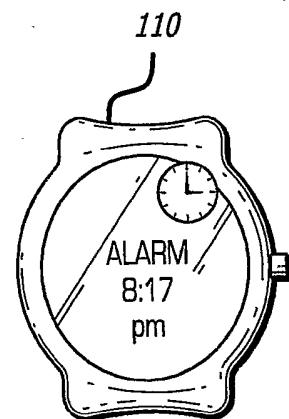

FIG. 53E

REFERENCES CITED IN THE DESCRIPTION

This list of references cited by the applicant is for the reader's convenience only. It does not form part of the European patent document. Even though great care has been taken in compiling the references, errors or omissions cannot be excluded and the EPO disclaims all liability in this regard.

Patent documents cited in the description

- GB 2112549 A [0006]