

(12) PATENT
(19) AUSTRALIAN PATENT OFFICE

(11) Application No. AU 199675937 B2
(10) Patent No. 705236

(54) Title
Method for manufacturing diffusers for shower heads

(51)⁶ International Patent Classification(s)
B05B 001/18

(21) Application No: 199675937 (22) Application Date: 1996 .11 .11

(87) WIPO No: W097/18041

(30) Priority Data

(31) Number	(32) Date	(33) Country
9504004	1995 .11 .13	SE

(43) Publication Date : 1997 .06 .05
(43) Publication Journal Date : 1997 .07 .31
(44) Accepted Journal Date : 1999 .05 .20

(71) Applicant(s)
Nils Larsson

(72) Inventor(s)
Nils Larsson

(74) Agent/Attorney
FISHER ADAMS KELLY,GPO Box 1413,BRISBANE QLD 4001

(56) Related Art
US 5405089
DE 2235217
DE 3044310

OPI DATE 05/06/97 APPLN. ID 75937/96
AOJP DATE 31/07/97 PCT NUMBER PCT/SE96/01450



AU9675937

(CT)

(51) International Patent Classification 6 :

B05B 1/18

A1

(11) International Publication Number:

WO 97/18041

(43) International Publication Date:

22 May 1997 (22.05.97)

(21) International Application Number: PCT/SE96/01450

(22) International Filing Date: 11 November 1996 (11.11.96)

(30) Priority Data:
9504004-4 13 November 1995 (13.11.95) SE

(71)(72) Applicant and Inventor: LARSSON, Nils [SE/SE];
Dalavägen 50, S-421 68 Västra Frölunda (SE).

(74) Agent: GÖTEBORGS PATENTBYRÅ AB; P.O. Box 5005,
S-402 21 Göteborg (SE).

(81) Designated States: AL, AM, AT, AU, AZ, BA, BB, BG, BR,
BY, CA, CH, CN, CU, CZ, DE, DK, EE, ES, FI, GB, GE,
HU, IL, IS, JP, KE, KG, KP, KR, KZ, LC, LK, LR, LS,
LT, LU, LV, MD, MG, MK, MN, MW, MX, NO, NZ, PL,
PT, RO, RU, SD, SE, SG, SI, SK, TJ, TM, TR, TT, UA,
UG, US, UZ, VN, ARIPO patent (KE, LS, MW, SD, SZ,
UG), Eurasian patent (AM, AZ, BY, KG, KZ, MD, RU, TJ,
TM), European patent (AT, BE, CH, DE, DK, ES, FI, FR,
GB, GR, IE, IT, LU, MC, NL, PT, SE), OAPI patent (BF,
BI, CF, CG, CI, CM, GA, GN, ML, MR, NE, SN, TD, TG).

Published

With international search report.
In English translation (filed in Swedish).

(54) Title: METHOD FOR MANUFACTURING DIFFUSORS FOR SHOWER HEADS

(57) Abstract

The present invention relates to a method for manufacturing a jet diffuser for a shower head or the like, which jet diffuser is manufactured by two parts, a hole washer (13) of a hard plastic material and a nozzle washer (14) of an elastic rubber or plastic material. The nozzle washer (14) is manufactured, preferably by injection moulding, with a plain bottom disk (21) and with socket shaped nozzles (22) substantially perpendicularly arranged in relation to this, and raised from the bottom disk socket shaped nozzles (22). The hole washer (13) is manufactured, preferably by injection moulding, with at least one arched underside (15) and with the holes (16) arranged in diverging directions. The nozzle washer is brought to contact with the arched underside of the hole washer, so that the socket shaped nozzles are pressed into and partially through the holes, whereby the nozzles are subjected to a directional change according to the holes in the hole washer. The nozzles (22) provided with an expanded end section (23) are pressed so far into the holes (16) of the hole washer (13) that the end section is expanded behind a shoulder (19) provided in the hole.

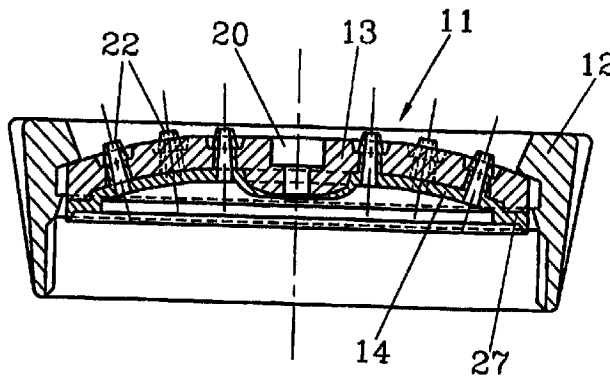

METHOD FOR MANUFACTURING DIFFUSORS FOR SHOWER HEADS

TECHNICAL FIELD

5

The present invention relates to a method for manufacturing a jet diffuser for a shower head or the like, which jet diffuser is manufactured by two parts, a hole washer (13) of a hard plastic material and a nozzle washer (14) of an elastic rubber or plastic material.

10

BACKGROUND OF THE INVENTION

For long, it has been desired to clean the holes in a jet diffuser to shower armatures in an easy way. In the patent literature there are some different suggestions, of which only a few have been used in practice, however. Besides pollution, which can block the holes in the jet diffuser, lime deposits are the big problem. In DE 3107808 C2 a self cleaning head is suggested, where the water outlet openings are constituted by rubber elastic, pipe-like nozzle, which in an uninfluenced manner are closed and opened under the influence of water pressure. Since the nozzle are closed when the water is off, the thought was that the deposits would not be able to dry and get stuck in the nozzle. In a later development of a shower head according to DE 3943062 A1 it is suggested that the rubber elastic nozzle can be influenced by a device (a slide) which sweeps over the end sections of the nozzle, so that lime deposits can be broken loose and be rinsed.

25

Further, in the DE 4308599 A1 a shower head is suggested of above described type, i.e. comprising a hole washer of a hard plastic material and a nozzle washer of a rubber elastic material, where the nozzle washer with the help of an injection moulding tool is shaped directly toward the hole washer. Since the jet pattern of the shower is given, i.e. the single jets shall have diverging directions in relation to each other, complicated moulds are required, giving each nozzle an exact alignment.

30

DE 30 44 310 A1 describes a shower device with jet openings comprising elastic, pivotable piece of a hose, which by a slide or the like can be pivoted or turned for optional directional control of the jets.

5

DE 22 35 217 A discloses a shower device, which diffuser consists of a flexible washer, which by a means active at the center of the washer, can be brought to adopt a concave or a convex position, with the purpose to control the jet openings of the washer in different directions.

10

PURPOSE OF THE INVENTION AND MOST CHARACTERISING PARTS

The purpose of the invention is to provide a cheap product, which can be manufactured with simple injection moulding methods and tools keeping the established jet pattern of the shower. This object has been solved by manufacturing the nozzle washer, preferably by injection moulding, with a plain bottom disk and with socket shaped nozzles substantially perpendicularly arranged in relation to this, and raised from the bottom disk socket shaped nozzles, that the hole washer is manufactured, preferably by injection moulding, with at least one arched underside and with the holes arranged in diverging directions, that the nozzle washer is brought to contact with the arched underside of the hole washer, so that the socket shaped nozzles are pressed into and partially through the holes, whereby the nozzles are subjected to a directional change according to the holes in the hole washer.

25

DESCRIPTION OF THE DRAWINGS

The invention will be further described in an embodiment referring to the drawings.

30

Fig. 1 shows a section through the jet diffuser according to the invention and its means of attachment.

Fig. 2 shows a section through the hole washer of the jet diffuser.

Fig. 3 shows a section through the nozzle washer of the jet diffuser.

Fig. 4 shows a view from above of the jet diffuser according to fig. 1.

5 Fig. 5 and 6 show an enlarged portion of the hole washer and the nozzle washer before and after the mounting.

DESCRIPTION OF THE PREFERRED EMBODIMENT

10 In Fig. 1 only a part of a shower head is visualised, namely the jet diffuser 11 and a means of attachment 12, in the form of a ring shaped nut, with which jet diffuser is fixed to the housing of the shower head, which is not shown, alternatively the means of attachment can also have the purpose of controlling the amount of the water percolation.

15 The jet diffuser 11 consists of two parts, a hole washer 13 and a nozzle washer 14, which under operation are connected to each other as presented in figure 1.

20 The hole washer 13 är manufactured of a hard plastic material, which even at temperatures at approximately 100 degrees centigrade is stable in form and which at least underside 15 is arched. In the hole washer 13, a number of holes 16 are arranged, which are arranged in diverging directions in relation to one another in accordance with the jet pattern, which the jet diffuser will have. The holes 16 are divided into an upper conical part 17 and a lower conical part 18, the first mentioned part having larger diameter than the lower part, so that that in the transition between these a shoulder 19 is arranged. Further, the hole washer can be provided with a central hole 20 for a screw, which fixes the hole washer to the shower head.

25 The nozzle washer 14 consists of a rubber elastic material and comprises a plain bottom disk 21 and from this raised socket shaped nozzles 22. These are designed with an expanded section 23 which via a flange 26 passes to a neck 24, which substantially is of the same length as the axial length of the hole part 18. The inner channel 25 of the

nozzle is slightly conical in the direction of the nozzle openings. The expanded section 23 is dimensioned so that the flange 26 in the transition to the neck 24 can catch behind over the shoulder 19, when the hole washer and the nozzle washer are assembled.

5 The nozzle washer 14 is manufactured, suitably by injection moulding in a plain position with the nozzles 22 arranged substantially perpendicularly in relation to the bottom disk 21. This design and choice of conicity of the expanded section 23 and the inner channel 25 of the nozzles results in that the nozzle washer 14 can be manufactured by simple form tools, high manufacturing capacity and at low price. The
10 same goes for the hole washer 13, where the double, opposite conicity of the hole parts 17 and 18 facilitates using simple form tools.

At the mounting of the nozzle washer 14 against the hole washer 13, which is accomplished by pressing the overside against the underside of the other part, the
15 nozzles 22 will be forced to adjust to the position, which holes 16 of the hole washer take, so that the desired jet pattern of the jet diffusor is obtained.

Any further special fixing of the nozzle washer in relation to the hole washer is not required, since the snap action of the flange 26 of the expanded section 23 behind the
20 shoulder 19 of the holes 16 is fully adequate. The nozzle washer 14 can also be designed with a peripheral sealing ring 27, which seals against the housing of the shower head.

3. Shower jet diffuser arranged to perform the method according to claim 2,
c h a r a c t e r i z e d i n,
that each nozzle (22) is designed with an expanded end section (23) on a neck (24), the
length of which corresponds to the axial length of the lower hole part (18) of the hole
5 washer, and which transition (26) between the neck (24) and the expanded end section
(23) is snapped in behind a shoulder (19) in one of the holes of the hole washer (13).

CLAIMS

THE AUSTRALIAN PATENT OFFICE

PO1/ SE 96/ 0145
7 1 1997

1. Method for manufacturing a jet diffusor for a shower head or the like, which jet diffusor is manufactured by two parts, a hole washer (13) of a hard plastic material and a nozzle washer (14) of an elastic rubber or plastic material, whereby the nozzle washer (14) is manufactured, preferably by injection moulding, with a plain bottom disk (21) and with socket shaped nozzles (22) substantially perpendicularly arranged in relation to this, and raised from the bottom disk socket shaped nozzles (22), that the nozzle washer is brought into contact with the arched underside of the hole washer, so that the socket shaped nozzles are pressed into and partially through the holes, characterized in that the hole washer (13) is manufactured, preferably by injection moulding, with at least one arched underside (15) and with the holes (16) arranged in diverging directions, whereby when introducing nozzle washer (14) into the hole washer (13) the nozzles are subjected to a directional change according to the holes in the hole washer (13), and that the nozzles (22) provided with an expanded end section (23) are pressed so far into the holes (16) of the hole washer (13) that the end section is expanded behind a shoulder (19) provided in the hole.

2. Method according to claim 1, characterized in, that the holes (16) in the hole washer (13) are divided into two parts, an upper part (17) with larger diameter and a lower part (18) with smaller diameter, that a shoulder (19) is arranged in the transition between the hole parts, and that the hole parts (17, 18) are arranged with double, opposite conicity.



AMENDED SHEET

FIG. 1

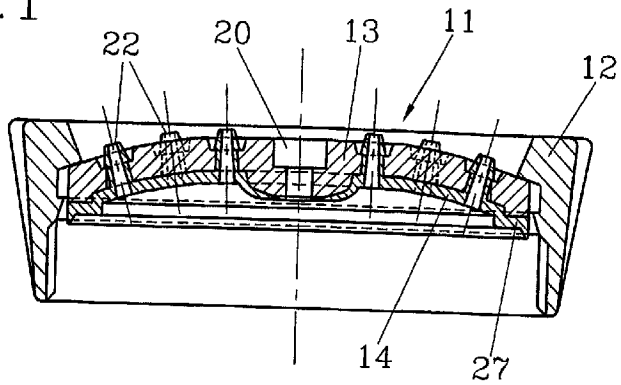

FIG. 2

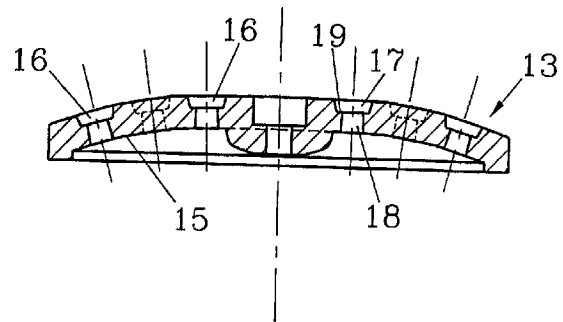

FIG. 3

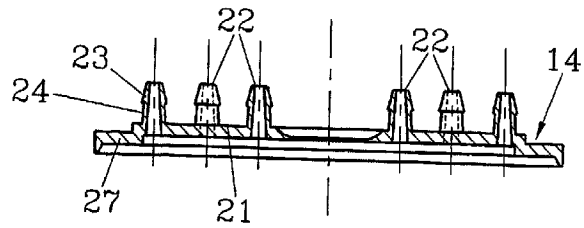

FIG. 4

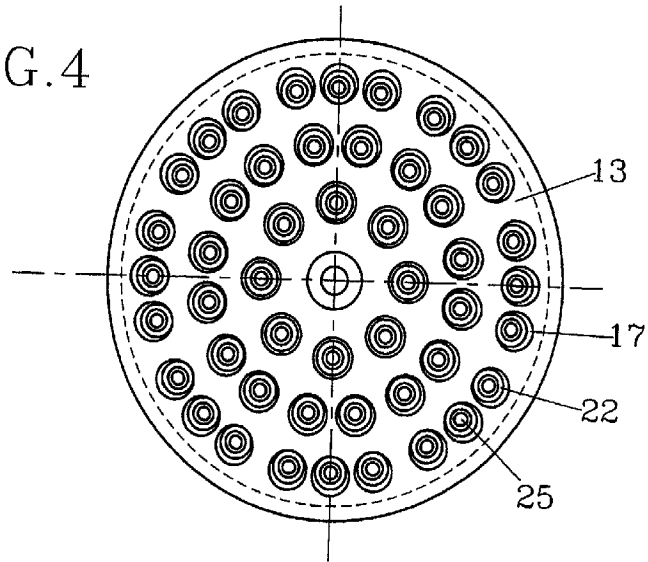

FIG. 5

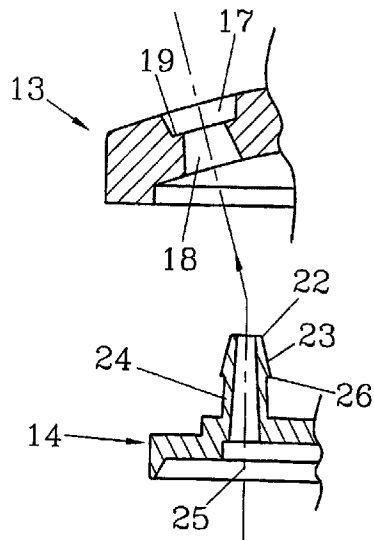

FIG. 6

