

L. B. MILLER.
DEVICE FOR MAKING JEWELS.
APPLICATION FILED NOV. 12, 1917.

1,298,540.

Patented Mar. 25, 1919.

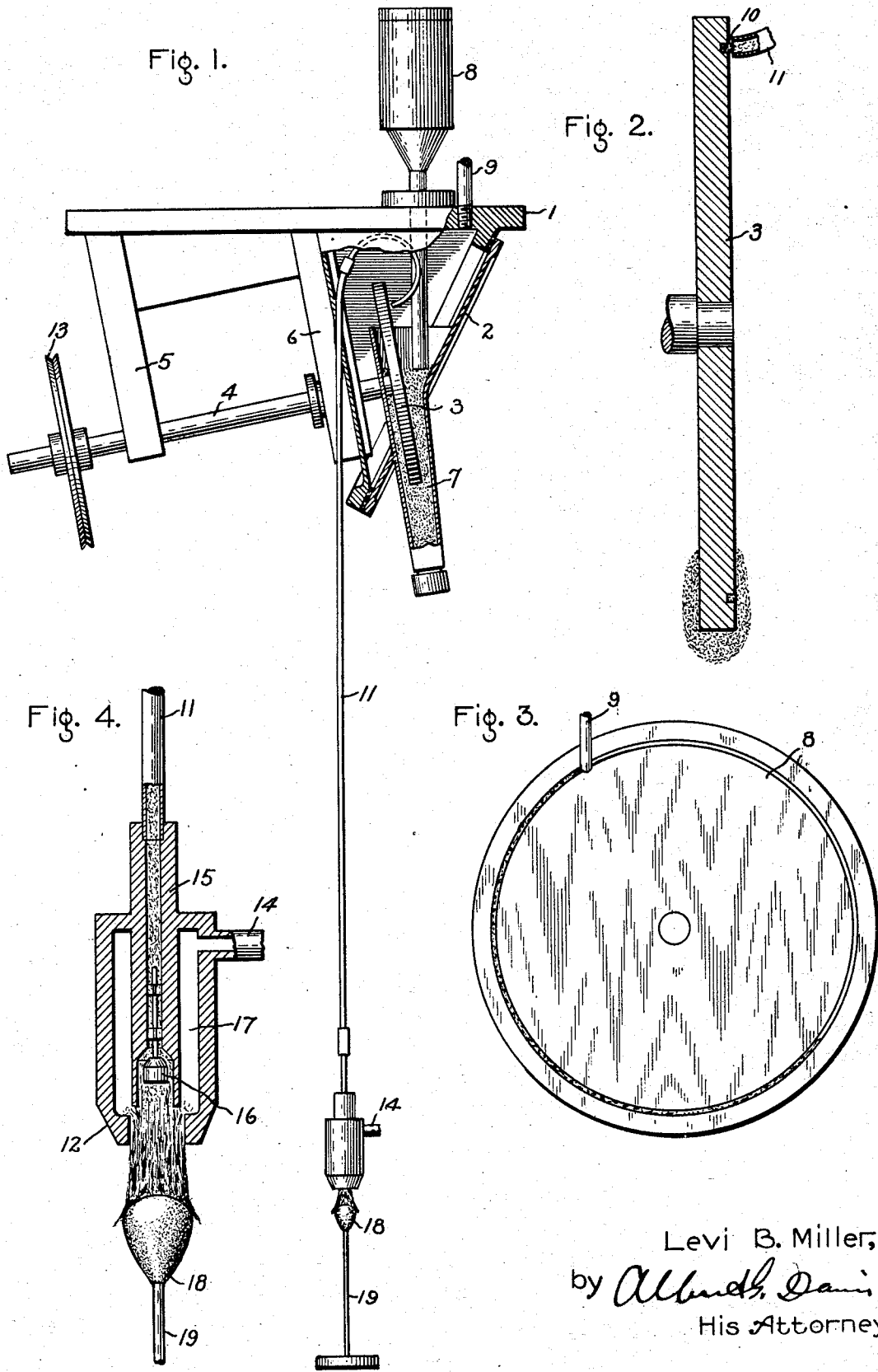

Levi B. Miller,
by *Alfred Davis*
His Attorney.

UNITED STATES PATENT OFFICE.

LEVI B. MILLER, OF LYNN, MASSACHUSETTS, ASSIGNOR TO GENERAL ELECTRIC COMPANY, A CORPORATION OF NEW YORK.

DEVICE FOR MAKING JEWELS.

1,298,540.

Specification of Letters Patent. Patented Mar. 25, 1919.

Application filed November 12, 1917. Serial No. 201,619.

To all whom it may concern:

Be it known that I, LEVI B. MILLER, a citizen of the United States, residing at Lynn, in the county of Essex, State of Massachusetts, have invented certain new and useful Improvements in Devices for Making Jewels, of which the following is a specification.

The present invention relates to an apparatus for making artificial sapphires, or similar jewels, by fusing in a flame finely divided alumina or other suitable powdered jewel-forming material, and the main objects of the invention are to prepare jewels free from bubbles or other flaws and of suitable shape and size for use as bearings for instruments or for ornamental purposes.

Two main features of the invention constitute improved means for securing a steady feed of powder and a proper distribution of powder in a flame in which the powder is fused and built up into a clear mass or jewel body.

In accordance with one of the features of my invention the charge of powdered jewel forming material is fed to a gas stream leading to the burner by means of a rotating wheel or disk provided with an annular recess in which the powder is picked up by rotation of the wheel, and carried to a gas-conveying tube.

In accordance with another feature of my invention the distribution of the jewel forming charge in the gas is made more uniform by providing in the inner tube of the burner a deflector for spreading the powder from the center of the gas stream to the periphery.

My invention will be more clearly understood by reference to the following description taken in connection with the accompanying drawing in which Figure 1 is a perspective view partly in section of the entire apparatus; Fig. 2 is a sectional view of the distributing disk; Fig. 3 is a side elevation of the disk; and Fig. 4 is an enlarged detailed sectional view of the burner.

The apparatus shown in Fig. 1 comprises a frame 1 consisting of wood, metal or other suitable material on which is mounted the closed receptacle 2, containing a distributing disk or wheel 3 which is rotatably mounted by means of shaft 4 on the supports 5, 6, which are in turn attached to the frame-work 1. The disk 3 projects into a pocket 7 containing the charge of aluminum

oxid or other material which is to be built up into a jewel. This charge is introduced through a hopper 8 in the desired amounts.

One of the gases which is used for producing heat in the burner is introduced by means of a tube 9 under suitable pressure into the receptacle 2. I prefer to introduce into this chamber oxygen at suitable pressure but in a similar manner hydrogen may be introduced and the oxygen added to the burner. The rotating disk 3 is provided with a recess or groove 10, shown in Figs. 2 and 3, in which a small quantity of the powdered charge is picked up by the rotation of the disk. To make a filling of the groove more certain the disk is slightly tipped, as indicated in the drawing. As any portion of the periphery of the disk emerges from the charge the portion of the charge picked up by the groove is retained due to its cohesion and its adhesion to the disk. Near the top of the disk and very close to the groove is the entrance of the gas outlet tube 11 which in some cases may be contracted. The gas under pressure in the receptacle 2 flowing into this tube causes a suction which picks up the powder and conveys the same with the gas to the burner 12, as shown more clearly in Fig. 4. The rate of feed of the powdered material may be adjusted by the speed of rotation of the disk which is driven by pulley 13 belted to any suitable motor.

At the lower end of the oxygen-conveying chamber 15 within the gas burner there is provided a deflector 16, the upper part of which is somewhat cone-shaped. This deflector by being suitably positioned within the widened outlet of the chamber 15 counteracts the tendency of the powdered charge to concentrate near the center of the gas stream. The material is spread toward the periphery of the gas stream adjacent the wall of the tube a short distance from the outlet of the chamber 15 where the flowing oxygen gas comes into contact with hydrogen gas supplied from the annular chamber 17 in the burner through a supply tube 14. The powder is deposited on a jewel mass 18 which is supported on the end of a refractory rod 19.

By the time the powder has reached the point of admixture where the combustion of the commingling gas occurs the powder has scattered so that it is nearly evenly distributed within the flame. This construction also

causes the outside of the oxygen stream to move at somewhat greater velocity thereby increasing the temperature at this region and thus counteracting the tendency of too great a concentration of heat in the center of the flame. In this way the heated zone through which the powder passes and the area on the jewel mass 18 on which the heated powder falls is maintained at a more uniform temperature instead of having the center too hot and the outside too cool. The speed of the particles is also reduced, which facilitates the working out of bubbles in the fused jewel mass.

15 What I claim as new and desire to secure by Letters Patent of the United States, is:—

1. An apparatus for making artificial jewels, comprising a closed receptacle, adapted to contain a charge of powdered jewel-forming material, a wheel having a recess, rotatably mounted within said receptacle, and located to pick up powder in said recess during rotation, a gas-conveying tube having an inlet adjacent said groove, means for rotating said wheel, means for introducing gas into said receptacle, and a burner for receiving the gas conveyed by said tube for producing combustion under conditions adapted to fuse and build up a charge of jewel-forming powder in said gas into a jewel body.

2. An apparatus for making artificial jewels, comprising a closed receptacle, adapted to contain a charge of powdered jewel-forming material, a grooved wheel rotatably mounted within said receptacle, and located to pick up powder in said groove during rotation, a gas-conveying tube having an inlet adjacent said groove, means for rotating said wheel, means for introducing gas into said receptacle, a jewel-forming burner for receiving gas conveyed by said tube and a centrally located deflector at the outlet of said powder-conveying tube for spreading said powdered material.

3. An apparatus for making jewels comprising a burner, a conduit for conveying a combustible gas to said burner, a second con-

duit for conveying a combustion-supporting gas to said burner, a chamber communicating with one of said conduits adapted to receive a charge of jewel-forming powder, a conveyer located within the chamber for delivering powder to the communicating conduit at a practically uniform rate, and means for receiving a deposit of said material by a flame from said burner.

4. A burner for forming jewels comprising a gas-conveying tube having an enlarged terminal section for receiving a gas charged with powder to be fused, a deflector located in said enlarged section and an annular chamber communicating with said section for supplying a gas capable of combining with said powder-carrying gas.

5. A burner for a jewel-forming apparatus, comprising means for supplying a combustible gas and a combustion supporting gas, one of said gases bearing a charge of powder, and means for deflecting said powder away from the center of the gas stream conveying the same.

6. A feed mechanism for a jewel-forming device comprising a closed chamber adapted to contain a charge of powdered jewel-forming material, a conduit having an inlet located in said chamber for conveying said material to a jewel-forming flame, and means for supplying to the inlet of said conduit jewel-forming material limited at all times not to exceed a predetermined amount.

7. The process of making artificial jewels which consists in conveying a current of combustible gas and a current of combustion-supporting gas to a burner through separate conduits, continuously supplying at a substantially uniform predetermined rate a charge of powdered jewel-forming material to one of said gas currents, producing combustion of said gases, and building up said material in a fused state into a jewel body by the heating effect of said combustion.

In witness whereof, I have hereunto set my hand this 7th day of November 1917.

LEVI B. MILLER.