



(11) **EP 3 567 185 B1**

(12) **EUROPEAN PATENT SPECIFICATION**

(45) Date of publication and mention of the grant of the patent:

14.06.2023 Bulletin 2023/24

(21) Application number: **19183301.1**

(22) Date of filing: **09.07.2012**

(51) International Patent Classification (IPC):

E04F 15/02^(2006.01) E04F 15/04^(2006.01)

(52) Cooperative Patent Classification (CPC):

E04F 15/02038; E04F 2201/0146; E04F 2201/0153; E04F 2201/0176; E04F 2201/0535; E04F 2201/0547

(54) **MECHANICAL LOCKING SYSTEM FOR FLOOR PANELS**

MECHANISCHES ARRETIERUNGSSYSTEM FÜR BODENPLATTEN

SYSTÈME DE VERROUILLAGE MÉCANIQUE POUR PANNEAUX DE PLANCHER

(84) Designated Contracting States:

AL AT BE BG CH CY CZ DE DK EE ES FI FR GB GR HR HU IE IS IT LI LT LU LV MC MK MT NL NO PL PT RO RS SE SI SK SM TR

(30) Priority: **11.07.2011 SE 1150660**

11.07.2011 US 201161506282 P

(43) Date of publication of application:

13.11.2019 Bulletin 2019/46

(62) Document number(s) of the earlier application(s) in accordance with Art. 76 EPC:

12811602.7 / 2 732 109

(73) Proprietor: **Ceraloc Innovation AB**

263 64 Viken (SE)

(72) Inventor: **PERVAN, Darko**

SE-263 61 VIKEN (SE)

(74) Representative: **Välinge Innovation AB**

Patent Department

Prästavägen 513

263 64 Viken (SE)

(56) References cited:

WO-A1-03/025307

WO-A1-03/089736

WO-A1-2006/043893

WO-A1-2006/123988

WO-A1-2008/060232

WO-A2-2007/015669

US-A- 2 430 200

US-A1- 2008 010 931

Note: Within nine months of the publication of the mention of the grant of the European patent in the European Patent Bulletin, any person may give notice to the European Patent Office of opposition to that patent, in accordance with the Implementing Regulations. Notice of opposition shall not be deemed to have been filed until the opposition fee has been paid. (Art. 99(1) European Patent Convention).

EP 3 567 185 B1

Description

TECHNICAL FIELD

[0001] The disclosure generally relates to the field of mechanical locking systems for floor panels and building panels. Furthermore, floorboards, locking systems, installation methods and production methods are shown.

FIELD OF APPLICATION OF THE INVENTION

[0002] The present invention is particularly suitable for use in floating floors, which are formed of floor panels which are joined mechanically with a locking system integrated with the floor panel, i.e. mounted at the factory, are made up of one or more upper layers of veneer, decorative laminate or decorative plastic material, an intermediate core of wood-fibre-based material or plastic material and preferably a lower balancing layer on the rear side of the core. The following description of known technique, problems of known systems and objects and features of the invention will therefore, as a non-restrictive example, be aimed above all at this field of application and in particular at laminate flooring formed as rectangular floor panels with long and short edges intended to be mechanically joined to each other on both long and short edges. The long and short edges are mainly used to simplify the description of the invention. The panels may be square. It should be emphasised that the invention may be used in any floor panel and it may be combined with all types of known locking systems, where the floor panels are intended to be joined using a mechanical locking system connecting the panels in the horizontal and vertical directions on at least two adjacent sides. The invention may thus also be applicable to, for instance, powder based floors, solid wooden floors, parquet floors with a core of wood or wood-fibre-based material and a surface of wood or wood veneer and the like, floors with a printed and preferably also varnished surface, floors with a surface layer of plastic or cork, linoleum, rubber. Even floors with hard surfaces such as stone, tile and similar materials are included and floorings with soft wear layer, for instance needle felt glued to a board. The invention may also be used for joining building panels which preferably contain a board material for instance wall panels, ceilings, furniture components and similar.

BACKGROUND OF THE INVENTION

[0003] Laminate flooring usually comprise a core of a 6-12 mm fibre board, a 0.2-0.8 mm thick upper decorative surface layer of laminate and a 0.1-0.6 mm thick lower balancing layer of laminate, plastic, paper or like material. A laminate surface may comprise melamine-impregnated paper. The most common core material is fibreboard with high density and good stability usually called HDF - High Density Fibreboard. Sometimes also MDF - Medium Density Fibreboard - is used as core.

[0004] Traditional laminate floor panels of this type have been joined by means of glued tongue-and-groove joints.

[0005] In addition to such traditional floors, floor panels have been developed which do not require the use of glue and instead are joined mechanically by means of so-called mechanical locking systems. These systems comprise locking means, which lock the panels horizontally and vertically. The mechanical locking systems are usually formed by machining of the core of the panel. Alternatively, parts of the locking system may be formed of a separate material, for instance aluminium or HDF, which is integrated with the floor panel, i.e. joined with the floor panel in connection with the manufacture thereof.

[0006] The main advantages of floating floors with mechanical locking systems are that they are easy to install. They may also be disassembled and used once more at a different location. However, there is still a need to improve the locking strength and to reduce the material costs.

DEFINITION OF SOME TERMS

[0007] In the following text, the visible surface of the installed floor panel is called "front side", while the opposite side of the floor panel, facing the sub floor, is called "rear side". The edge between the front and rear side is called "joint edge". By "horizontal plane" is meant a plane, which extends parallel to the outer part of the surface layer. Immediately juxtaposed upper parts of two adjacent joint edges of two joined floor panels together define a "vertical plane" perpendicular to the horizontal plane. By "vertical locking" is meant locking parallel to the vertical plane in D1 direction. By "horizontal locking" is meant locking parallel to the horizontal plane in D2 direction. By "first horizontal locking" is meant a horizontal locking perpendicular to the joint edges in D2 direction. By "second horizontal locking" is meant a horizontal locking in the horizontal direction along the joint which prevents two panels to slide parallel to each other when they are laying in the same plane.

[0008] By "locking systems" are meant co acting connecting elements, which connect the floor panels vertically and/or horizontally. By "mechanical locking system" is meant that joining may take place without glue. Mechanical locking systems may also be joined by gluing. By "integrated with" means formed in one piece with the panel or factory connected to the panel.

[0009] By "*up or upward*" means toward the surface and by "*down or downward*" means toward the rear side. By "*inwardly*" is meant towards the centre of the floorboard and by "*outwardly*" means in the opposite direction.

[0010] By "*carving*" is meant a method to form a groove or a protrusion on an edge of a panel by carving a part of the edge to its final shape by one or several carving tool configurations comprising several non-rotating and fixed chip-removing surfaces located along the feeding

direction.

RELATED ART AND PROBLEMS THEREOF

[0011] A flooring system according to the preamble of claim 1 is known from WO2008/060232.

[0012] For mechanical joining of long edges as well as short edges in the vertical and in the first horizontal direction perpendicular to the edges several methods may be used. One of the most used methods is the angle-snap method. The long edges are installed by angling. The panel is then displaced in locked position along the long side. The short edges are locked by horizontal snapping. The vertical connection is generally a tongue and a groove. During the horizontal displacement, a strip with a locking element is bent and when the edges are in contact, the strip springs back and a locking element enters a locking groove and locks the panels horizontally. Such a snap connection is complicated since a hammer and a tapping block may need to be used to overcome the friction between the long edges and to bend the strip during the snapping action.

[0013] Similar locking systems may also be produced with a rigid strip and they are connected with an angling-angling method where both short and long edges are angled into a locked position.

[0014] Recently new and very efficient locking systems have been introduced with a separate flexible or displaceable integrated tongue on the short edge that allows installation with only an angling action, generally referred to as "vertical folding". Such a system is described in WO 2006/043893 (Välinge Innovation AB). Several versions are used on the market as shown in figures 1a-1f. 1a, 1b shows a flexible tongue 30 with a flexible snap tab extending from the edge. Figure 1c, 1d shows a displaceable tongue with an inner flexible part that is bendable horizontally in a cross section of the tongue or along the joint. Such systems are referred to as vertical snap systems. The locking system may also be locked with a side push action such that a displaceable tongue 30 is pushed into a locked position from the long side edge when adjacent short side edges are folded down to the sub floor. Figure 1e shows a fold down system with a flexible tongue 30 that is made in one piece with the core. Figure 1f shows a long edge locking system in a fold down system that is connected with angling.

[0015] All such locking systems comprise a horizontal locking, which is accomplished by cooperating hook element in the form of a strip with a locking element cooperating with a locking groove.

[0016] Several versions of fold down systems are described in WO2006/104436, WO2007/015669, WO2008/004960, WO2010/087752 (Välinge Innovation AB).

[0017] Although such systems are very efficient, there is still room for improvements. It is difficult to insert the separate tongue 30 during production into a groove 40 over a strip 6 comprising a locking element 8. The locking

groove 14 reduces the strength and the edges may crack.

[0018] The protruding locking strip with the locking element causes a waste when the edges are machined and such waste may be considerable in wide tile-shaped floorboards.

[0019] It is a major advantage if the strip 6 is more compact and shorter and if the locking element 8 and the locking groove 14 are eliminated.

[0020] One of the main advantages with the fold down systems is that there is no requirement that the long edges should be displaceable. In fact it is an advantage if the long edges do not slide during angling since a flexible tongue that is used in some systems presses the short edges apart during folding.

[0021] WO 2006/043893 describes a fold down system with an essentially horizontal protruding strip that does not have a locking element. Such fold down system has no horizontal connection and the short edges may be locked by for example gluing or nailing to the sub floor. It would be an advantage if such floorboards could be installed in a floating manner.

[0022] Such a floating installation may be accomplished according to this disclosure with a locking system that comprises long edges that are locked in a first horizontal direction perpendicular to the edge and in a second horizontal direction along the edge. Long edges that are not displaced after locking will also keep the short edges together and prevent separation.

[0023] It is known that a separation of short edges of floor panels may be prevented with increased friction or with projections and spaces between the long edges that will counteract mutual displacements along the edge and consequently prevent the short edges to slide apart.

[0024] It is for example known from Wilson US 2,430,200 that several projections and recesses between a tongue and a groove in a mechanical locking system may be used to prevent displacement along the joint. Such projections and recesses are difficult to produce, the panels can only be locked in well-defined positions against adjacent long edges and they cannot be displaced against each other in angled position when top edges are in contact.

[0025] Terbrack US 4,426,820 describes an impractical locking system with a perfect fit in a panel made of plastic material. The perfect fit may prevent displacement along the joint.

[0026] WO1994/026999 (Välinge Innovation AB) describes a mechanical locking system that locks vertically and horizontally and where a rubber strip or any other sealing device is applied in the groove or between the flat projection part of the strip and the adjacent panel edge as shown principally in figure 1f. A rubber strip may be used to increase friction along the joint.

[0027] WO98/22677 (Golvabia) describes a tongue and groove joint where several different types of materials are used to increase friction in order to prevent the edges from sliding apart perpendicularly to the edge. Example of materials inserted or applied in the tongue and

groove joint are flock, strip-shaped bands of rubber, plastic, foamed rubber adhesive coated surfaces in which friction-increasing material is fixed such as sand, plastic or rubber particles. Roughened or coarsened surfaces may also be used.

[0028] WO03/025307 and WO03/089736 (Välinge Innovation AB) describe that displacement along long edges may be counteracted or prevented by means of high friction, glue, mechanical means etc. and that the short edges may be formed merely with vertical locking means or completely without locking means. WO03/012224 (Välinge Innovation AB) describes that flexible elastic sealing compounds based on acrylic plastics, elastomers of synthetic rubber, polyurethane-based hot-melt adhesives, etc. may be applied between the horizontal locking surfaces in order to compensate moisture movements due to swelling or shrinking. Such elastically material will increase the friction and prevent displacement of long edges along the joint.

[0029] Wernersson WO2004/083557 discloses floor panels with mechanical locking means wherein predetermined surfaces of the edges are provided with splines. There is no disclosure of the geometry of such mechanical locking means, how such splines are formed and on which surfaces they are applied.

[0030] WO 2006/123988 (Välinge Innovation AB) describes a panel with a slide locking system comprises a plurality of small local protrusions that prevents displacement along the joint edges when the panels are laying flat on the sub floor. The protrusions may lock against a flexible rubber material at the adjacent panel. The short edges are provided only with a vertical locking comprising a tongue made in one piece with the core. The panels may be locked with vertical folding and the slide lock prevents sliding along the joint after folding. A folding system at the short edges that only locks vertically and which comprise a flexible separate tongue is not described.

[0031] These known technologies to prevent displacement along the long edges suffer from several disadvantages. Friction created by pressure and small hard materials is not reliable since swelling and shrinking in wood fibre based panels may change the friction forces, thus the panels may as time goes slide and the short edges separate from each other. Friction material that is applied on surfaces that form active horizontal locking surfaces, such as the locking surfaces of the locking element and the locking groove and upper adjacent joint edges may change the locking geometry and prevent an easy installation.

SUMMARY

[0032] A first overall objective of the present invention is to provide a locking system for primarily rectangular floor panels with long and short edges installed in parallel rows, which allows that the short edges may be locked to each other with a vertical movement without a horizontal connection and that such horizontal connection is

accomplished by the locking system on the long edges comprising a first and second horizontal locking perpendicular to the edges and along the edges.

[0033] The invention is based, in part, on the discovery that since displacement of the long edges is not needed in a fold down locking system, there is more freedom to design the long edges locking system.

[0034] The costs and functions should be favourable compared to known technology. A part of the overall objective is to improve the function and costs of those parts of the locking system that locks in the second horizontal direction along the joint when panels are installed on a sub floor.

[0035] More specifically the object is to provide a second horizontal locking system on the long edges, hereafter referred to as "slide lock" where one or several of the following advantages are obtained.

[0036] The slide lock on the long edges should be activated when a panel is brought in contact with an already installed panel and then angled down to the sub floor.

[0037] The slide lock function should be reliable over time and the panels should be possible to lock and unlock in any position when two adjacent long edges are brought into contact with each other.

[0038] The slide lock should be strong and prevent short edges of two locked panels from separating when humidity changes or when people walk on a floor.

[0039] The slide lock should be possible to lock with high precision and without the use of tools.

[0040] The locking system and the slide lock should be designed in such a way that the material and production costs are low and that flexible materials may be applied in a safe way without the risk that such separate materials will be included in the active locking surfaces in an uncontrolled way.

[0041] The invention is based on a general approach that the locking element and the locking groove at the long edges should be used to accomplish a horizontal locking perpendicular to the edge but also along the edge.

[0042] The above objects of the invention are achieved by the flooring system as set out in claim 1.

[0043] Embodiments of the invention are evident from the description and drawings.

[0044] A first aspect of the invention is a flooring system comprising a plurality of rectangular floor panels with short edges and long edges. The panels are adapted to be installed on a sub floor and connected to each other with a mechanical locking system for locking the panels vertically and horizontally. Said locking system comprising a tongue and a tongue groove for mechanically locking together adjacent edges vertical to the horizontal plane, thereby forming a vertical mechanical connection between the panels. A locking element at a first long edge and a locking groove at an opposite second long edge form a first horizontal mechanical connection between adjacent long edges locking the panels to each other in a direction parallel to the horizontal plane and at right angles to said adjacent long edges. The panels are pro-

vided with a short edge locking connection comprising a separate tongue for locking adjacent short edges in a first vertical direction, inserted in a fixation groove at a short edge of a panel. The tongue is preferably at least partly flexible and/or displaceable. The short edge locking connection further comprises a locking strip and a locking cavity for locking adjacent short edges in a second vertical direction. The short edge locking connection is configured to lock the adjacent edges in a vertical direction only. The long edges are provided with a second horizontal mechanical connection locking the panels to each other along said adjacent long edges, in a direction parallel to the horizontal plane and parallel to said adjacent long edges, when the panel are laying flat on the sub floor.

[0045] Said second horizontal mechanical connection at the long edges may comprises a locking element and locking groove with two sets of cooperating locking surfaces, wherein a first set is located closer to a vertical plane (VP) and the upper joint edges than a second set.

[0046] The two sets of locking surfaces may be inclined such that a lower part of the locking element is larger than an upper part.

[0047] The vertical extension of the second set of locking surfaces may be essentially the same or larger than the vertical extension of the first set of locking surfaces. The long edge locking system may comprises a third set of cooperating locking surfaces located at the outer and lower part of the strip.

[0048] There may be a space between the upper part of the locking element and the locking groove.

[0049] Said second horizontal mechanical connection may comprise a flexible material which is applied in an essentially vertical groove.

[0050] Said second horizontal mechanical connection may comprise a flexible material, which is compressed horizontally in two opposite directions

[0051] Said second horizontal mechanical connection may comprise a flexible material, which is located in an essentially vertical groove that is complementary with a wedge shaped locking element.

[0052] Said second horizontal mechanical connection may comprise a friction element located on the upper part of the locking element that cooperates with a friction groove. The friction groove may comprise a flexible material.

[0053] Said second horizontal mechanical connection may comprise friction cavities located at the locking element.

[0054] Said second horizontal mechanical connection may comprise compressible material that is applied in the locking system at surfaces that do not comprise cooperative active locking surfaces that lock the panels vertically and horizontally.

[0055] The short edge locking connection may be locked with a vertical snap action where the separate tongue is displaced in the fixation groove during vertical displacement.

[0056] The short edge locking connection may be locked when the separate tongue is displaced in the fixation groove along the short edge.

[0057] According to the invention, the locking system at the long edges comprises a locking element and locking groove with two sets of cooperating locking surfaces. A first set is located closer to a vertical plane and the upper joint edges than a second set. The locking surfaces are preferably inclined such that a lower part of the locking element is larger than an upper part. It is preferred that there is a space between the upper part of the locking element and the locking groove. Such a space may be used to give more production tolerances. Preferably, the vertical extension of the second set of locking surfaces is essentially the same or larger than the vertical extension of the first set of locking surfaces.

[0058] According to the invention the long edge locking system comprises a flexible material located in a vertical groove that prevents displacement along the edges. The flexible material is preferably located between cooperating surfaces of the locking element and the locking groove.

[0059] According to a third embodiment of the invention the long edge locking system comprises at least three sets of cooperative locking surfaces between a locking element located on a strip and a locking groove. The first and the second sets are located in the upper part of the locking element wherein the first set is closer to the upper edges than the second set. The third set is located on the lower and outer part of the strip. This geometry is used to accomplish a strong press fit between the locking element and the locking groove and the panels will be tightly secured to each other such that displacement along the long edges and perpendicular to the short edges will be prevented.

[0060] Such a locking system with a press fit may be made much stronger than conventional locking systems with hooks at the short edges.

[0061] Said second mechanical connection may comprise a flexible tongue which is inserted in a fixation groove formed in the locking groove.

[0062] The above-described locking system at the long edges may also be used just individually to lock one pair of two adjacent edges, preferably the long edges, horizontally perpendicularly to the edges and along the edges. Such a locking system may be used together with many other types of locking systems at the other pair of adjacent edges, preferably the short edges, and may contribute to increase the horizontal locking strength at the short edges considerably. This is especially an advantage in large floors, with a length or width exceeding for example 20 m, and which are for example installed in commercial areas where the load on the floor may be considerable.

[0063] A second aspect of the invention is two floor panels provided with a locking system comprising a tongue and a tongue groove for mechanically locking together adjacent edges vertical to the horizontal plane,

thereby forming a vertical mechanical connection between the panels. The locking system further comprises a first horizontal mechanical connection between adjacent edges for locking the panels to each other in a direction parallel to the horizontal plane and at right angles to said adjacent edges. The first horizontal mechanical connection comprises a locking element at a first edge and a locking groove at an opposite second edge. The tongue may be a separate tongue, preferably at least partly flexible and/or displaceable, inserted in a fixation groove at an edge of a panel. The locking system further comprises a second horizontal mechanical connection locking the panels to each other along said first and second edge, in a direction parallel to the horizontal plane and parallel to said adjacent edges, when the panels are laying flat on a sub floor.

[0064] The locking element and the locking groove preferably comprise two sets of cooperating locking surfaces, wherein a first set is located closer to a vertical plane (VP) and the upper joint edges than a second set.

[0065] At least one of the two sets of cooperating locking surfaces may comprise a flexible material. The flexible material may be a flexible tongue inserted in a fixation groove. The fixation groove may be formed in the locking groove.

[0066] The two sets of locking surfaces may be inclined such that a lower part of the locking element is larger than an upper part.

[0067] The vertical extension of the second set of locking surfaces may be essentially the same or larger than the vertical extension of the first set of locking surfaces. The locking system may comprise a third set of cooperating locking surfaces located at the outer and lower part of the strip.

[0068] There may be a space between the upper part of the locking element and the locking groove.

[0069] According to the invention, said second horizontal mechanical connection comprises a flexible material, which is applied in an essentially vertical groove, said flexible material is compressed horizontally in two opposite directions. The flexible material may be complementary with a wedge shaped locking element.

[0070] Said second horizontal mechanical connection may comprise a friction element located on the upper part of the locking element that cooperates with a friction groove. The friction groove may comprise a flexible material.

[0071] Said second horizontal mechanical connection may comprise friction cavities located at the locking element.

[0072] Said second horizontal mechanical connection may comprise compressible material that is applied in the locking system at surfaces that do not comprise cooperative active locking surfaces that lock the panels vertically and horizontally.

[0073] The edges may be locked with a vertical snap action where the separate tongue is displaced in the fixation groove during vertical displacement.

[0074] The edges may be locked when the separate tongue is displaced in the fixation groove along the short edge.

5 BRIEF DESCRIPTION OF THE DRAWINGS

[0075] The disclosure will in the following be described in connection to exemplary embodiments and in greater detail with reference to the appended exemplary drawings, wherein:

10 Figs 1a-f illustrate locking systems according to known technology.

Figs 2a-d illustrate a short edge locking system according to preferred embodiments of the invention.

15 Figs 3a-3f illustrate a long edge locking system.

Figs 4a-c illustrate an preferred embodiment of short edge locking system.

20 Figs 5a-f illustrate exemplary separate tongues that may be used in to lock short edges.

Figs 6a-f illustrate preferred embodiments of the invention.

25 Figs 7a-c illustrate a long edge locking system according to an embodiment of the invention.

Figs 8a-8b illustrate vertical folding with a conventional locking system and a locking system according to an embodiment of the invention.

30 Figs 9a-9d illustrate preferred embodiments of the invention.

DESCRIPTION OF EMBODIMENTS OF THE INVENTION

35 **[0076]** To facilitate understanding, several locking systems in the figures are shown schematically. It should be emphasised that improved or different functions may be achieved using combinations of the preferred embodiments. The inventor has tested all known and especially
40 all commercially used locking systems on the market that are installed with vertical folding in all type of floor panels, especially laminate and wood floorings and the conclusion is that at least all these known locking systems which have one or more locking elements cooperating with locking grooves may be adjusted to a system with a slide lock on the long edges which prevents displacement along the adjacent edges and with fold down locking system on short edges that only locks vertically. The most preferable embodiments are however based on floorboards
45 with a surface layer of laminate, powder based paper free surfaces or wood surfaces, a core of HDF or wood and a locking system on the long edge with a strip extending beyond the upper edge which allows locking by angling combined with a tongue and groove joint on the short edges comprising a separate tongue which preferably only locks vertically.

50 **[0077]** All embodiments may be used separately or in combinations. Angles, dimensions, rounded parts, spac-

es between surfaces, etc. are only examples and may be adjusted within the basic principles of the invention.

[0078] Figures 2a -2d show a first preferred embodiment of a short edge locking system provided with a flexible and displaceable tongue 30 in a first edge 1 inserted in a fixation groove 40 that cooperated with a tongue groove 20 in an adjacent second panel 1' and locks the panels in a first vertical direction according to known technology. The first panel 1 (strip panel) comprises a protruding strip 6 that extends outwardly beyond a vertical plane VP. The second panel 1' comprises a locking cavity 7 that cooperates with the locking strip 6 and locks the panels in a second vertical direction. Figure 2e show that the panels are only locked vertically and that they may be released or connected horizontally in essentially the same plane since there is no locking element on the strip and no hook connections in the locking system that prevents such horizontal displacement.

[0079] Such a locking system may be more cost efficient than convectional fold down systems since there is no need for a protruding strip with a locking element. Softer, thinner and less costly core materials may be used in a locking system that only is used for vertical locking. The horizontal locking may be obtained with a slide lock system at the long edges.

[0080] Figure 3a and 3b show a slide lock system according to the invention comprising a tongue 10 and a tongue groove 9, a locking strip 6, a locking element 8 and a locking groove 14. A flexible and compressible material 16 such as synthetic or natural rubber or plastic foam is applied in the upper part of the locking groove 14 as a layer on the upper part of the locking element 8. The upper part of the locking element 8 is formed such that two horizontally opposite edges press against the compressible material 16a, 16b. In a wood floor with a lamella core, the locking element and the locking groove will be formed across the fibre orientation. The swelling and shrinking in the horizontal direction along the wood fibres is extremely small and will not cause any dimensional changes of the fitting tolerances between the locking element 8 and the locking groove 14. The counter pressure will not have any effect on the locking tolerances and swelling and shrinking of this part of the locking system will easily be compensated by the flexibility of the compressible material even in other wood based materials such as HDF, chipboard or plywood. It is preferred that the upper part of the locking element is wedge formed and that it cooperates with a complementary groove 14. It is preferred that the inner part of the groove 14 is smaller than the groove opening. This design may be used to create a friction connection even without compressible material.

[0081] Figures 3c and 3d show a locking system with at least three sets of cooperative locking surfaces between the locking element 8 and the locking groove 14. The first 11,12 and the second 21,22 sets are located in the upper part of the locking element wherein the first set is closer to the upper edges 4,5 than the second set. The

third set 23,24 is located, preferably below the first and the second sets, preferably on the lower and outer part of the strip 6. The locking surfaces are essentially flat but they may also be curved. The locking surfaces are preferably inclined. Preferably the angle A1 against a horizontal plane HP of the first set of cooperated surfaces should be slightly smaller than the angle A3 of the third set. This geometry may be used to accomplish an easy locking with angling and a strong press fit between the locking element 8 and the locking groove 14 and the panels will be tightly secured to each other such that displacement along the long edges and perpendicular to the short edges will be prevented. Preferably all or some of the cooperating sets of surfaces are made with angles A1, A2, A3 that are between 40 - 80 degrees against the horizontal plane or even more preferably between 45 and 75 degrees.

[0082] In wood cores, such as plywood or wood lamella core, it is preferred the fibre orientation is mainly perpendicular to the length direction of the edges. Layers in the plywood core may be adapted such that at least one set of cooperation surfaces comprises such fibre orientation that will provide a very high friction and a strong locking along the joint.

[0083] Such a locking system with a press fit with or without additional preferably flexible friction increasing materials between the locking element and the locking groove, may be made much stronger than conventional locking systems with hooks at the short edges. A horizontally extending groove 35 may be formed in a wall or the locking groove 14 in order to increase the flexibility of one of the locking surfaces 23 in the third set of locking surfaces. A similar mainly vertical groove 35a may also be formed in the strip 6. The forming may be made with rotating tools or carving tools.

[0084] The locking element and the locking groove may be formed in a very precise manner if high precision profiling is used where several tools are positioned at the same tool station such that the upper edge 4 and the locking element are formed at the same time in order to eliminate turning of the panels during machining. The locking groove and the upper edge 5 may be formed in the same way.. The locking system may also be formed partly or completely with carving tools that allow forming of more complex geometries with undercuts.

[0085] The above described slide lock systems are preferably used on long edges and in combination with a fold down locking system on short edges as shown in figures 2a - 2d.

[0086] Figures 3e,f show that the flexible material may be combine with or replaced by with a flexible and preferable displaceable tongue 30 in one of the edges that is inserted in a fixation groove 40 and comprises a part, preferably an outer part, that is in contact with an adjacent edge and prevents displacement of the edges along the joint. The flexible tongue 30 is preferably inserted in a fixation groove 40 that is formed in the locking groove 14. The outer part of the tongue preferably comprises

small and sharp locking protrusions that increase the longitudinal friction. The tongue may be fixed into the fixation groove 40 with friction and/or glue. One or several tongues 30 may be attached to a one edge, preferably the long edge of a floor panel.

[0087] Figure 3e shows a locking system comprising a tongue 10 and a strip on the same edge 2. This geometry saves material when the locking system is formed. The adjacent panel 2' comprises a tongue groove 9 with an upper 9a and a lower lip 9b that cooperates with the tongue 10 for vertical locking. The locking groove 14 comprises a fixation groove 40 that may be inclined in order to facilitate easy insertion of the flexible tongue 30 into the fixation groove 40. An outer sliding surface 30a of the flexible tongue 30 is during angling sliding against a siding surface 8a on the locking element and the flexible tongue is displaced inwardly and outwardly in the fixation groove. All types of tongues, which comprise at least one part that is flexible, may be used. The outer part of the flexible tongue may be wedge formed and may in locked position press with pre tension into the tongue groove 20a. The upper part of the tongue groove 20a is in this example inclined upwards and outwardly such that the panels may be unlocked with an angling action.

[0088] The fixation groove may be formed in the outer part of the strip 6 and it is also possible to replace the flexible tongue 30 with a sharp nail made of for example plastic or metal, preferably aluminium.

[0089] Figure 3f shows a locking system with a flexible tongue 30 that presses against an upper part 21 of the locking element 8. Such a locking system may have a flexible tongue that may only be displaced with a distance of less than 0,5 mm. Even 0,1-0,2 mm may be sufficient to provide a locking.

[0090] All described embodiments may be combined. The slide lock system may also be combined with a conventional one piece tongue 10 and groove 9 system on the short edges. The flexible tongue may be designed such that it allows some displacement especially if a hammer and a tapping block is used. Two panels may also be connected with the short edges partly or completely and may thereafter be angled into a locked position at long edges.

[0091] The fixation groove may extend along the whole length or may be a local groove with a length that may be slightly longer than the length of the flexible tongue 30.

[0092] The slide lock system may also be used independently to lock panels at one pair of opposite edges and may be combined with any type of locking system at another pair of edges, preferably short edges. The slide lock system may be used to improve the overall locking of the panels and to increase the locking strengths at another pair of edges. This may be an advantage in thin panels or soft core material such as for example PVC where it is difficult to form large locking element. It is also suitable for narrow panels where the length of the locking element is rather small. Material savings may be obtained in for example a lamella core wood material where a sep-

arate, stronger and more expensive material usually is used at the short edges to form the strip and the locking element.

[0093] Figure 4a-4c show that the separate tongue may be attached to the fold panel 1'.

[0094] Figures 5a-5d show that all known tongues may be used in the short edge locking system. Figure 5a shows a bow shaped tongue and figure 5b shows a bristle tongue. Such tongues are bended in length direction during locking. Figure 5c shows a wedge tongue that is displaced with a side push action from the long edge such that it is displaced both along and perpendicular to the edge into the tongue groove 20. Figure 5d shows a side push rigid tongue that is only displaced along the edge such that the protrusions on the tongue overlap the protrusions formed in the tongue groove 20.

[0095] Figure 5e shows a flexible tongue 30 that may be used to prevent displacement along the edge. The tongue comprises friction connections 31 that are located in the inner part of the fixation groove 40 and locking protrusion 32 that may be in contact with the adjacent edge, preferably an outer part of the locking element 8. Tongues as shown in figures 5a and 5b may also be used.

[0096] Figure 5f shows a locking system that comprises a flexible tongue 30 and that is in a locking position whereby one of the edges 2' is angled to the sub floor. The flexible tongue 30 is in contact with the outer part of the strip when the locking element 8 and the locking groove 14 overlaps each other. This specific geometry prevents separation of the edges during angling.

[0097] Figures 6a-6f show that all known fold down systems may be adapted to a locking system according to an embodiment of the invention by removing a part the locking element and preferably a part of the strip 6. This will provide cost savings due to less waste and a stronger joint. It is also possible to form a fold down system in very thin floorboards for example with a thickness of about 4-6 mm.

[0098] Figure 6d shows a side push system with a wedge shaped tongue and figure 6e shows a side push system with a tongue comprising protrusions. Even one-piece systems with a machined tongue as shown in figure 6f may be used. A short strip 6 provides a much easier machining of the undercut groove 41. This groove 41 may also be formed with carving

[0099] Figure 6d shows that all shown fold down locking systems may be adjusted such that the edge 6a may be formed without a protruding strip 6 and the tongue 30 may lock vertically upwards and downwards.

[0100] Figures 7a-7b show preferred embodiments. The long side locking system comprises a friction element 15, which in this embodiment is located on the upper part of the locking element 8, and that cooperates with a friction groove 17. One advantage is that no compressible material 16 is applied in the active locking surfaces 9a,9b,10a,10b,3,4,11,12 that lock the panels vertically and horizontally.

[0101] Figure 7c shows that the friction may be im-

proved if friction cavities 18 are formed on the upper part of the locking element 8 or in the friction element 15. Such cavities form expansion spaces for the flexible material 16 that may be applied with lower requirements on production tolerances. The cavities are preferably formed with a screw cutter as describe in WO2010/087752. Friction cavities 18' may also be formed on other parts of the locking system for example the outer part of the strip 6. Figures 8a and 8b show that known locking systems, as shown in figure 8a, may easily be converted to a locking system according to an embodiment of the invention, as shown in figure 8b, and that the new locking system may be compatible with the old locking system. Friction cavities 18 are formed in the upper part of the locking element with a screw cutter, compressible material 16 is preferably inserted essentially in the groove along the whole long edge or in parts thereof and the locking element on the short edges is removed. A flexible tongue may also be inserted into the long edge as described above.

[0102] The panels are installed such that a long edge 2" of a new panel in a second row is put at an angle against a long edge 2 of a first panel installed in a previous row and displaced until its short edge 1' is in contact with a short edge 1 of a second panel installed in the second row. The new panel is angled down whereby the flexible tongue 30 locks the short edges 1, 1' vertically. The long edges comprise a locking system with a friction connection that prevents displacement of the panels along the long edges 2, 2', 2".

[0103] Figure 9a shows that several friction elements 15, 15' and friction grooves 17, 17' with compressible material 16, 16, may be provided.

[0104] Figure 9b shows that the protruding strip 6 at short edges may be replaced by overlapping upper edges 33, 34 above the separate tongue 30. It is of course possible to use both overlapping edges and a locking strip 6 cooperating with a locking cavity 7.

[0105] Figure 9c shows that flexible and compressible material 16 may be applied on the friction element 15.

[0106] The long edge locking along the edge may be accomplished with a tight fit, with high friction or with all known methods to prevent displacement along the joint.

[0107] Wood floor with a lamella core that generally has a rough surface may be formed with a locking system with tight fit and with rather large cooperating locking surfaces. No flexible materials are needed to obtain sufficient friction. Such long side locking system is extremely difficult to displace, especially when the floor boards are long, for example 1.8 - 2.4 m and the friction force is generally sufficient to accomplish a locking which keeps the short edges together during the lifetime of the floor. Only a few small flexible tongues 30 may be provided at the long edges in order to give the necessary extra locking that may be needed in some applications and in very dry conditions when the wood material shrinks.

[0108] The locking strength of the slide lock may be increased considerably with a locking strip that is slightly

bended and that causes a permanent vertical pressure as shown in figure 9d. Sufficient friction may be created even in HDF material that generally is formed with rather smooth surfaces. A strip 6 that in locked position is bended backwards will press the locking element 8 into the locking groove 14 when people walk on the floor or when furniture is applied on the surface. This will increase the locking strength of the second horizontal connection along the long edges. The locking strength may be increased further if for example a pressing protrusion 23 is formed on the lower part of the strip, preferably under the locking element. Such pressing protrusion 23 may be applied as a separate material on essentially the whole strip 6 or on separate parts along the edge.

[0109] Wedge shaped locking elements 8 that are pressed into a cooperating locking groove 14 as shown in figure 9d may create a sufficient friction even without a compressible friction material. Figure 9d shows embodiment that comprises a locking element 8 and locking groove with two sets of cooperating locking surfaces. A first set 11, 12 is located closer to the vertical plane than a second set 21, 22. The locking surfaces are preferably inclined such that a lower part of the locking element is larger than an upper part. The locking surfaces may be essentially plane or curved. It is preferred that there is a space S between the upper part of the locking element and the locking groove. Such a space S may be used to give more production tolerances. The angle A1, A2 of the cooperating surfaces, or tangent line in case the surfaces are curved, should preferably be larger than about 45 degrees. Preferably the vertical extension of the second set 21, 22 of locking surfaces is essentially the same or larger than the vertical extension of the first set 11, 12 of locking surfaces. The second set should preferably extend downwards to a level, which is below the first set.

[0110] A flexing groove 34, 34' may be formed in the locking element 8 and/or behind the locking groove 14 in order to increase the flexibility of the walls of the locking element 8 or the locking groove 14. Such flexing groove may also be filled with a flexible material that increases the flexibility further.

[0111] A wedge shaped locking element as described above may be used to position the upper edges with a small play of for example of about 0.01 - 0.10 mm. Such a play will allow the top edges to swell and damages on the upper edges or squeaking sound will be eliminated. Such locking system is also very suitable to use in glue down floor installations or in combination with bevels between the upper joint edges.

[0112] The above-described embodiment may of course be combined with friction cavities 18 and flexible material 16 may be inserted between the locking element and the locking groove

[0113] The locking system may be formed with two or more sets of locking elements and locking grooves in order to increase the friction. Small friction grooves 23 parallel with the joint edge may also increase the friction.

[0114] Glue or wax that cures after some time is also

possible to use and may eliminate problems with shrinking and swelling of a pre tensioned locking system. Wax mixed with aluminium oxide particles, which are applied in the locking system, increases the friction considerably.

[0115] The long edge locking system may be used with all known vertical folding systems that lock the short edges vertically and horizontally.

[0116] The separate tongues are generally factory connected into an edge. Separate loose tongues that are inserted prior to folding or when two short edges are laying flat on the sub floor are not excluded.

[0117] The long edge locking system may be formed such that it is displaceable in an angle of 3-5 degrees. This facilitates installation around doors and similar.

[0118] The invention has been described above by way of example only and the skilled person will appreciate that various modifications may be made within the scope of the invention as defined by the appended claims.

Claims

1. A flooring system comprising a plurality of rectangular floor panels with short edges (1, 1') and long edges (2, 2', 2''), wherein

the panels are adapted to be installed on a sub floor and connected to each other with a long edge mechanical locking system for locking the panels vertically and horizontally, said locking system comprising a tongue (10, 30) and a tongue groove (9, 20) for mechanically locking together adjacent edges vertical to the horizontal plane (HP), forming a vertical mechanical connection between the panels, and a locking element (8) at a first long edge (2) and a locking groove (14) at an opposite second long edge (2') thereby forming a first horizontal mechanical connection between adjacent long edges (2, 2') locking the panels to each other in a direction parallel to the horizontal plane and at right angles to said adjacent long edges, wherein the panels are provided with a short edge locking connection comprising a separate tongue (30), for locking adjacent short edges (1, 1') in a first vertical direction, inserted in a fixation groove (40) at a short edge(1, 1') of a panel, wherein the separate tongue is at least partly flexible and/or displaceable, and a locking strip (6) and a locking cavity (7) for locking adjacent short edges (1, 1') in a second vertical direction, wherein the long edges are provided with a second horizontal mechanical connection locking the panels to each other along said adjacent long edges, in a direction parallel to the horizontal plane and parallel to said adjacent long edges, when the panel are laying flat on the sub floor,

characterised in that

the short edge locking connection is configured to lock the adjacent edges in the vertical directions only,

said second horizontal mechanical connection comprises a flexible and compressible material (16, 16a, 16b) which is applied in an upper part of said locking groove (14) as a layer, and wherein an upper part of said locking element (8) is formed such that two horizontally opposite edges of said locking element (8) press against said flexible and compressible material (16, 16a, 16b).

2. The flooring system as claimed in claim 1, wherein said second horizontal mechanical connection at the long edges comprises the locking element (8) and the locking groove (14) with two sets of cooperating locking surfaces (11,12 - 21, 22), wherein a first set (11,12) is located closer to a vertical plane (VP) and upper joint edges of two joined floor panels than a second set (21,22), wherein the vertical plane (VP) is defined by said upper joint edges, the vertical plane (VP) being perpendicular to the horizontal plane (HP).
3. The flooring system as claimed in claim 2, wherein the two sets of locking surfaces are inclined such that a lower part of the locking element (8) is larger than an upper part.
4. The flooring system as claimed in claim 2 or 3, wherein the vertical extension of the second set of locking surfaces (21,22) is essentially the same or larger than the vertical extension of the first set of locking surfaces (11,12).
5. The flooring system as claimed in any one of the claims 2-4, wherein the long edge locking system comprises a third set of cooperating locking surfaces (23,24) located at the outer and lower part of the strip (6).
6. The flooring system as claimed in any one of the claims 2-5, wherein there is a space (S) between the upper part of the locking element (8) and the locking groove (14).
7. The flooring system as claimed in claim 1, wherein said flexible material (16) is located in an essentially vertical groove (14) that is complementary with a wedge shaped locking element (8).
8. The flooring system as claimed in any one of the claims 1-7, wherein said second horizontal mechanical connection comprises a friction element (15) located on the upper part of the locking element (8) that cooperates with a friction groove (17).

9. The flooring system as claimed in claim 8, wherein the friction groove comprises a flexible material (16).
10. The flooring system as claimed in any one of the claims 1-9, wherein said second horizontal mechanical connection comprises friction cavities (18) located on the locking element (8).
11. The flooring system as claimed in any one of the claims the 1-10, wherein said second horizontal mechanical connection comprises compressible material that is applied in the locking system at surfaces that do not comprise cooperative active locking surfaces (3,4,9a,9b,10,10b,11, 12), which lock the panels vertically to the horizontal plane and horizontally in a direction parallel to the horizontal plane and at right angles to said adjacent long edges.
12. The flooring system as claimed in any one of the claims 1-11, wherein the short edge locking connection is locked with a vertical snap action where the separate tongue (30) is displaced in the fixation groove (40) during vertical displacement.
13. The flooring system as claimed in any one of the claims 1-11, wherein the short edge locking connection is locked when the separate tongue (30) is displaced in the fixation groove (40) along the short edge.

Patentansprüche

1. Bodenbelagsystem, umfassend eine Vielzahl von rechteckigen Bodenplatten mit kurzen Kanten (1, 1') und langen Kanten (2, 2', 2''), wobei die Platten angepasst sind, um auf einem Unterboden installiert zu werden und mit einem mechanischen Verriegelungssystem mit langer Kante zum vertikalen und horizontalen Verriegeln der Platten miteinander verbunden zu werden, das Verriegelungssystem umfassend eine Feder (10, 30) und eine Federnut (9, 20) zum mechanischen miteinander Verriegeln angrenzender Kanten vertikal zu der horizontalen Ebene (HP), was eine vertikale mechanische Verbindung zwischen den Platten ausbildet, und ein Verriegelungselement (8) an einer ersten langen Kante (2) und eine Verriegelungsnut (14) an einer gegenüberliegenden zweiten langen Kante (2'), wobei dadurch eine erste horizontale mechanische Verbindung zwischen angrenzenden langen Kanten (2, 2') ausgebildet wird, die die Platten in einer Richtung parallel zu der horizontalen Ebene und in rechten Winkeln zu den angrenzenden langen Kanten miteinander verriegeln, wobei

die Platten mit einer Verriegelungsverbindung mit kurzen Kanten versehen sind, umfassend eine separate Feder (30) zum Verriegeln angrenzender kurzer Kanten (1, 1') in einer ersten vertikalen Richtung, die in eine Fixierungsnut (40) an einer kurzen Kante (1, 1') einer Platte eingesetzt ist, wobei die separate Feder mindestens teilweise flexibel und/oder verschiebbar ist, und einen Verriegelungsstreifen (6) und ein Verriegelungshohlraum (7) zum Verriegeln angrenzender kurzer Kanten (1, 1') in einer zweiten vertikalen Richtung, wobei die langen Kanten mit einer zweiten horizontalen mechanischen Verbindung versehen sind, die die Platten entlang der angrenzenden langen Kanten in einer Richtung parallel zu der horizontalen Ebene und parallel zu den angrenzenden langen Kanten miteinander verriegelt, wenn die Platte flach auf dem Unterboden platziert sind,

dadurch gekennzeichnet, dass

die Verriegelungsverbindung mit langer Kante konfiguriert ist, um die angrenzenden Kanten nur in den vertikalen Richtungen zu verriegeln, die zweite horizontale mechanische Verbindung ein flexibles und komprimierbares Material (16, 16a, 16b) umfasst, das in einem oberen Teil der Verriegelungsnut (14) als eine Schicht aufgebracht ist, und

wobei ein oberer Teil des Verriegelungselements (8) derart ausgebildet ist, dass zwei horizontal gegenüberliegende Kanten des Verriegelungselements (8) gegen das flexible und komprimierbare Material (16, 16a, 16b) drücken.

2. Bodenbelagsystem nach Anspruch 1, wobei die zweite horizontale mechanische Verbindung an den langen Kanten das Verriegelungselement (8) und die Verriegelungsnut (14) mit zwei Sätzen zusammenwirkender Verriegelungsoberflächen (11, 12-21, 22) umfasst, wobei sich ein erster Satz (11, 12) näher an einer vertikalen Ebene (VP) und oberen Fugenkanten zweier gefügter Bodenplatten als ein zweiter Satz (21, 22) befindet, wobei die vertikale Ebene (VP) durch die oberen Fugenkanten definiert ist, wobei die vertikale Ebene (VP) zu der horizontalen Ebene (HP) senkrecht ist.
3. Bodenbelagsystem nach Anspruch 2, wobei die zwei Sätze von Verriegelungsoberflächen derart geneigt sind, dass ein unterer Teil des Verriegelungselements (8) größer als ein oberer Teil ist.
4. Bodenbelagsystem nach Anspruch 2 oder 3, wobei die vertikale Erstreckung des zweiten Satzes von Verriegelungsoberflächen (21, 22) im Wesentlichen gleich oder größer als die vertikale Erstreckung des

ersten Satzes von Verriegelungsoberflächen (11, 12) ist.

5. Bodenbelagsystem nach einem der Ansprüche 2 bis 4, wobei das Verriegelungssystem mit langen Kanten einen dritten Satz zusammenwirkender Verriegelungsoberflächen (23, 24) umfasst, der sich an dem äußeren und unteren Teil des Streifens (6) befindet. 5
6. Bodenbelagsystem nach einem der Ansprüche 2 bis 5, wobei ein Raum (S) zwischen dem oberen Teil des Verriegelungselements (8) und der Verriegelungsnut (14) vorhanden ist. 10
7. Bodenbelagsystem nach Anspruch 1, wobei sich das flexible Material (16) in einer im Wesentlichen vertikalen Nut (14) befindet, die mit einem keilförmigen Verriegelungselement (8) komplementär ist. 15
8. Bodenbelagsystem nach einem der Ansprüche 1 bis 7, wobei die zweite horizontale mechanische Verbindung ein Reibelement (15) umfasst, das sich auf dem oberen Teil des Verriegelungselements (8) befindet, das mit einer Reibungsnut (17) zusammenwirkt. 20
9. Bodenbelagsystem nach Anspruch 8, wobei die Reibungsnut ein flexibles Material (16) umfasst. 25
10. Bodenbelagsystem nach einem der Ansprüche 1 bis 9, wobei die zweite horizontale mechanische Verbindung Reibungshohlräume (18) umfasst, die sich auf dem Verriegelungselement (8) befinden. 30
11. Bodenbelagsystem nach einem der Ansprüche 1 bis 10, wobei die zweite horizontale mechanische Verbindung komprimierbares Material umfasst, das in dem Verriegelungssystem an Oberflächen aufgebracht wird, die keine zusammenwirkenden aktiven Verriegelungsoberflächen (3, 4, 9a, 9b, 10, 10b, 11, 12) umfassen, die die Platten vertikal mit der horizontalen Ebene und horizontal in einer Richtung parallel zu der horizontalen Ebene und in rechten Winkeln zu den angrenzenden langen Kanten verriegeln. 35
12. Bodenbelagsystem nach einem der Ansprüche 1 bis 11, wobei die Verriegelungsverbindung mit kurzer Kante mit einem vertikalen Schnappvorgang verriegelt ist, bei dem die separate Feder (30) während einer vertikalen Verschiebung in der Fixierungsnut (40) verschoben wird. 40
13. Bodenbelagsystem nach einem der Ansprüche 1 bis 11, wobei die Verriegelungsverbindung mit kurzer Kante verriegelt ist, wenn die separate Feder (30) in der Fixierungsnut (40) entlang der kurzen Kante ver- 45

schoben wird.

Revendications

1. Système de plancher comprenant une pluralité de panneaux de plancher rectangulaires avec des bords courts (1, 1') et des bords longs (2, 2', 2''), dans lequel

les panneaux sont conçus pour être installés sur un sous-plancher et reliés les uns aux autres avec un système de verrouillage mécanique de bord long pour verrouiller les panneaux verticalement et horizontalement, ledit système de verrouillage comprenant une languette (10, 30) et une rainure de languette (9, 20) pour verrouiller mécaniquement ensemble des bords adjacents verticalement par rapport au plan horizontal (HP), formant une liaison mécanique verticale entre les panneaux, et un élément de verrouillage (8) au niveau d'un premier bord long (2) et une rainure de verrouillage (14) au niveau d'un second bord long opposé (2') formant de ce fait une première liaison mécanique horizontale entre les bords longs adjacents (2, 2') verrouillant les panneaux les uns aux autres dans une direction parallèle au plan horizontal et à angles droits par rapport auxdits bords longs adjacents, dans lequel

les panneaux sont pourvus d'une liaison de verrouillage de bord court comprenant une languette séparée (30), pour verrouiller des bords courts adjacents (1, 1') dans une première direction verticale, insérée dans une rainure de fixation (40) au niveau d'un bord court (1, 1') d'un panneau, la languette séparée étant au moins partiellement souple et/ou déplaçable, et une bande de verrouillage (6) et une cavité de verrouillage (7) pour verrouiller des bords courts adjacents (1, 1') dans une seconde direction verticale,

dans lequel les bords longs sont pourvus d'une seconde liaison mécanique horizontale verrouillant les panneaux les uns aux autres le long desdits bords longs adjacents, dans une direction parallèle au plan horizontal et parallèle auxdits bords longs adjacents, lorsque les panneaux sont posés à plat sur le sous-plancher, **caractérisé en ce que**

la liaison de verrouillage de bord court est configurée pour verrouiller les bords adjacents uniquement dans les directions verticales, ladite seconde liaison mécanique horizontale comprend un matériau souple et compressible (16, 16a, 16b) qui est appliqué dans une partie supérieure de ladite rainure de verrouillage (14) en guise de couche, et

- dans lequel une partie supérieure dudit élément de verrouillage (8) est formée de telle sorte que deux bords opposés horizontalement dudit élément de verrouillage (8) appuient contre ledit matériau souple et compressible (16, 16a, 16b).
2. Système de plancher selon la revendication 1, dans lequel ladite seconde liaison mécanique horizontale au niveau des bords longs comprend l'élément de verrouillage (8) et la rainure de verrouillage (14) avec deux ensembles de surfaces de verrouillage coopérantes (11, 12 à 21, 22), dans lequel un premier ensemble (11, 12) est situé plus près d'un plan vertical (VP) et des bords de jonction supérieurs de deux panneaux de plancher joints qu'un deuxième ensemble (21, 22), dans lequel le plan vertical (VP) est défini par lesdits bords de jonction supérieurs, le plan vertical (VP) étant perpendiculaire au plan horizontal (HP).
 3. Système de plancher selon la revendication 2, dans lequel les deux ensembles de surfaces de verrouillage sont inclinés de telle sorte qu'une partie inférieure de l'élément de verrouillage (8) est plus grande qu'une partie supérieure.
 4. Système de plancher selon la revendication 2 ou 3, dans lequel l'extension verticale du deuxième ensemble de surfaces de verrouillage (21, 22) est essentiellement identique ou plus grande que l'extension verticale du premier ensemble de surfaces de verrouillage (11, 12).
 5. Système de plancher selon l'une quelconque des revendications 2 à 4, dans lequel le système de verrouillage de bord long comprend un troisième ensemble de surfaces de verrouillage coopérantes (23, 24) situé au niveau de la partie extérieure et inférieure de la bande (6).
 6. Système de plancher selon l'une quelconque des revendications 2 à 5, dans lequel il y a un espace (S) entre la partie supérieure de l'élément de verrouillage (8) et la rainure de verrouillage (14).
 7. Système de plancher selon la revendication 1, dans lequel ledit matériau souple (16) est situé dans une rainure (14) essentiellement verticale qui est complémentaire d'un élément de verrouillage en forme de coin (8).
 8. Système de plancher selon l'une quelconque des revendications 1 à 7, dans lequel ladite seconde liaison mécanique horizontale comprend un élément de friction (15) situé sur la partie supérieure de l'élément de verrouillage (8) qui coopère avec une rainure de friction (17).
 9. Système de plancher selon la revendication 8, dans lequel la rainure de friction comprend un matériau souple (16).
 10. Système de plancher selon l'une quelconque des revendications 1 à 9, dans lequel ladite seconde liaison mécanique horizontale comprend des cavités de friction (18) situées sur l'élément de verrouillage (8).
 11. Système de plancher selon l'une quelconque des revendications 1 à 10, dans lequel ladite seconde liaison mécanique horizontale comprend un matériau compressible qui est appliqué dans le système de verrouillage au niveau de surfaces qui ne comprennent pas de surfaces de verrouillage actives coopérantes (3, 4 9a, 9b, 10, 10b, 11, 12), qui verrouillent les panneaux verticalement par rapport au plan horizontal et horizontalement dans une direction parallèle au plan horizontal et à angles droits par rapport auxdits bords longs adjacents.
 12. Système de plancher selon l'une quelconque des revendications 1 à 11, dans lequel la liaison de verrouillage de bord court est verrouillée avec une action d'encliquetage vertical où la languette séparée (30) est déplacée dans la rainure de fixation (40) pendant un déplacement vertical.
 13. Système de plancher selon l'une quelconque des revendications 1 à 11, dans lequel la liaison de verrouillage de bord court est verrouillée lorsque la languette séparée (30) est déplacée dans la rainure de fixation (40) le long du bord court.

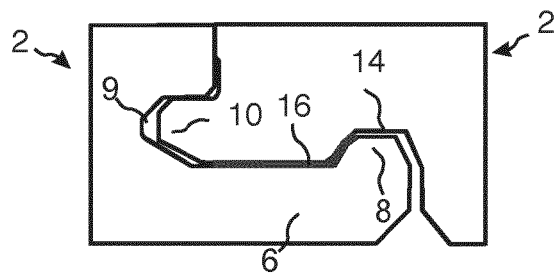
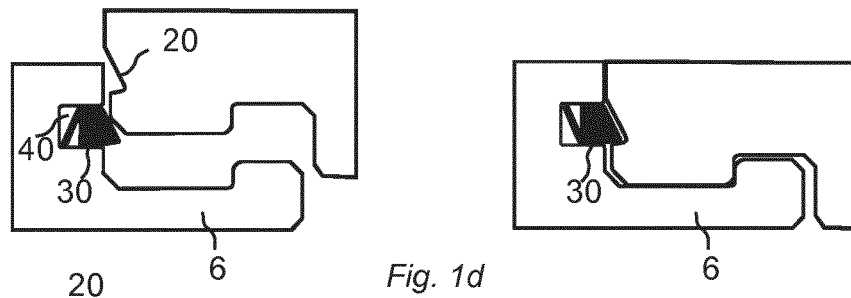
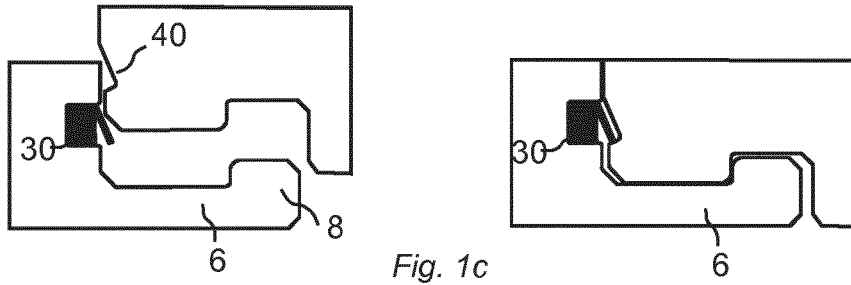
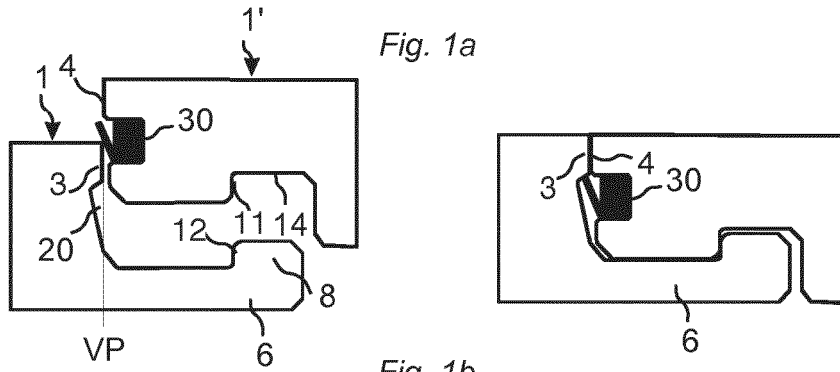

Fig. 2a

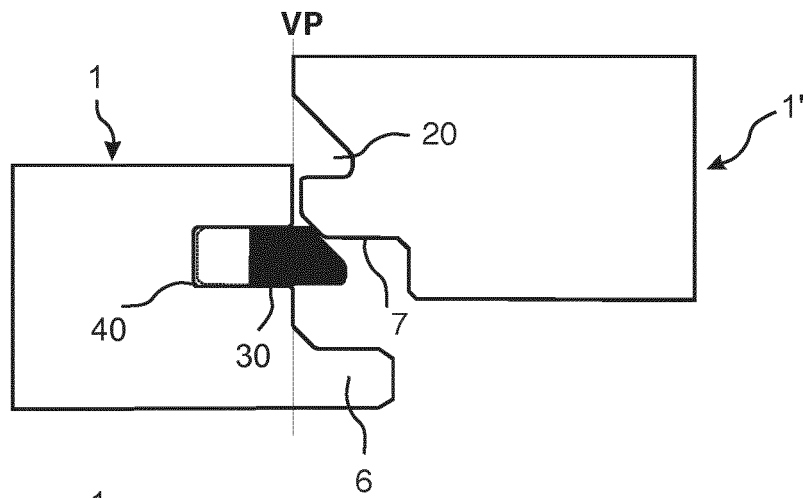

Fig. 2b

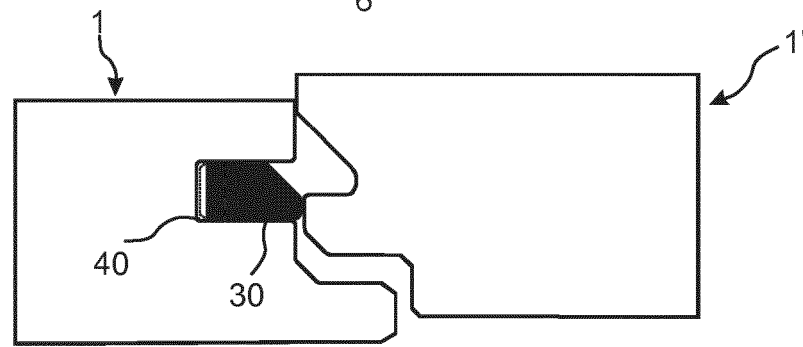

Fig. 2c

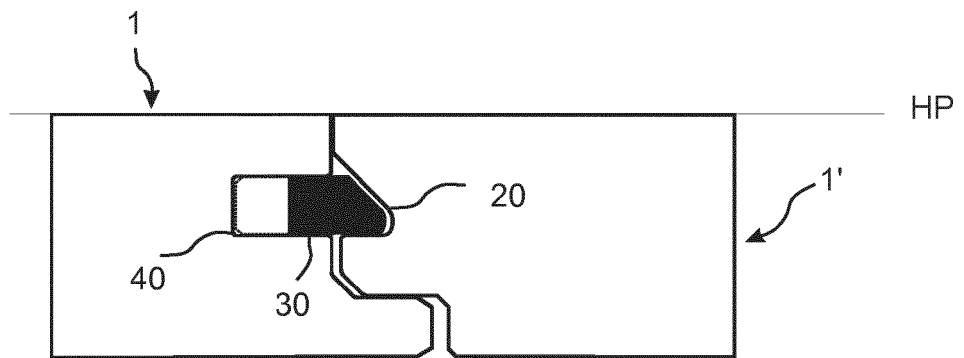

Fig. 2d

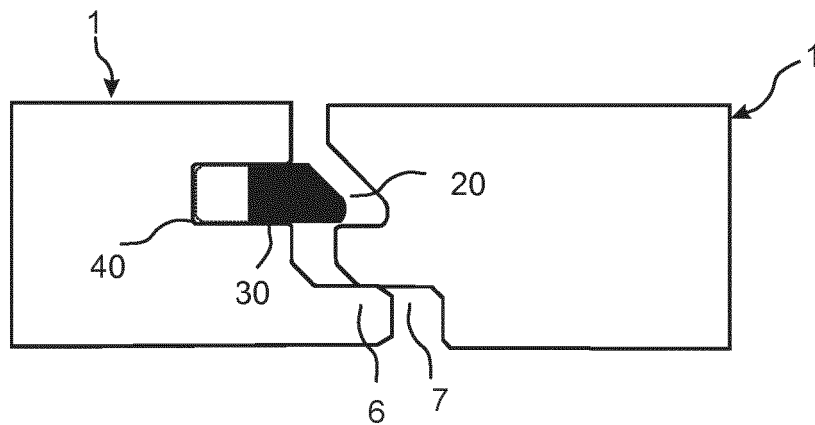

Fig. 3a

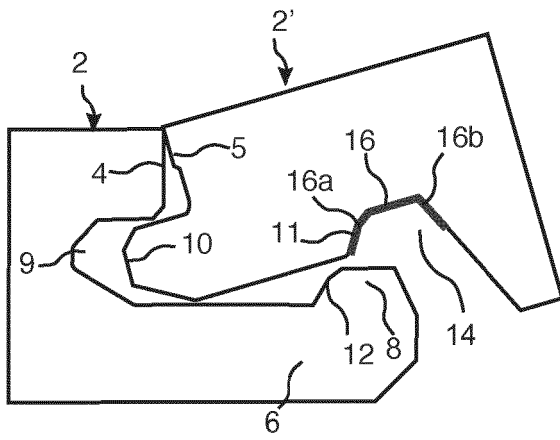

Fig. 3b

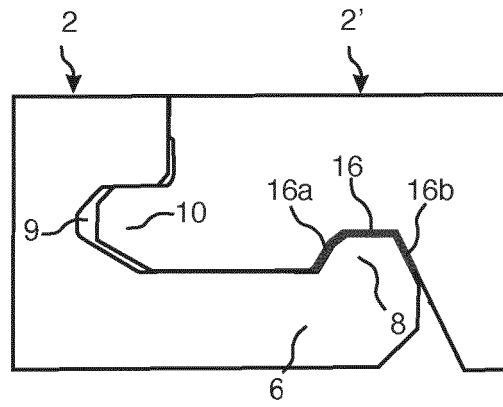

Fig. 3c

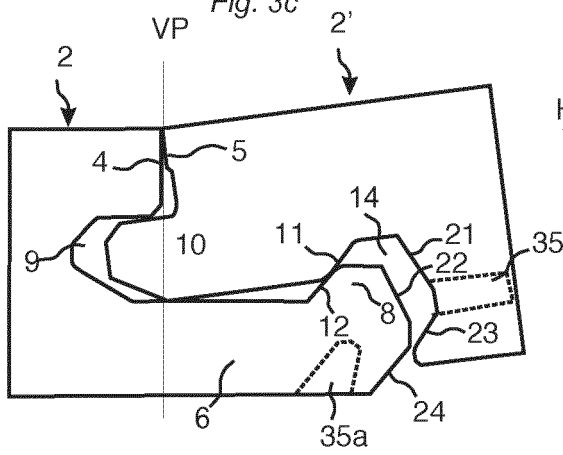

Fig. 3d

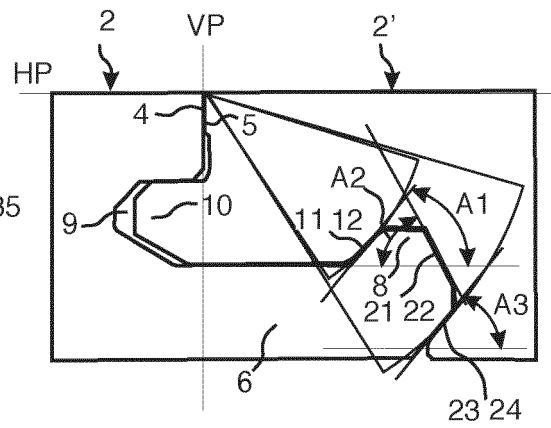

Fig. 3e

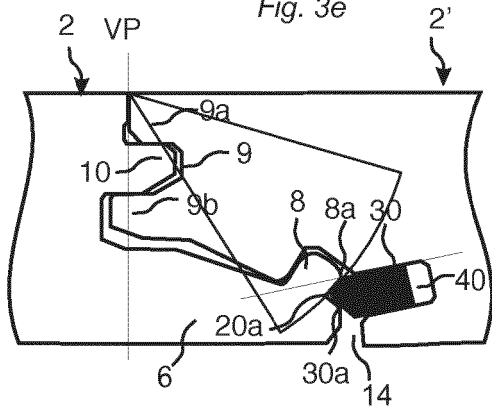

Fig. 3f

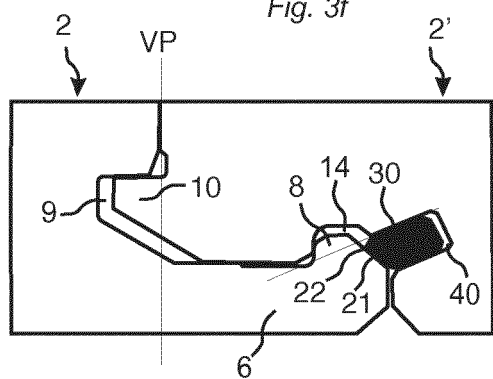

Fig. 4a

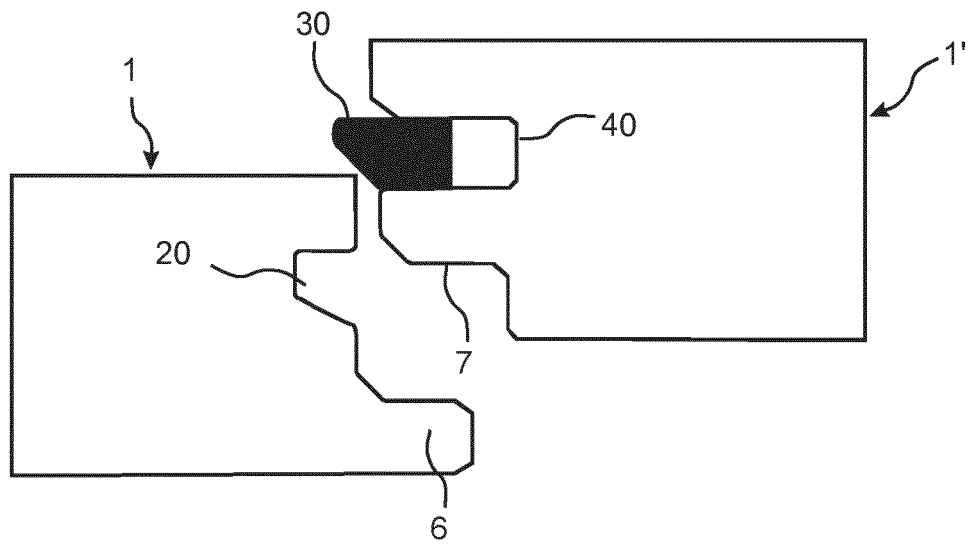

Fig. 4b

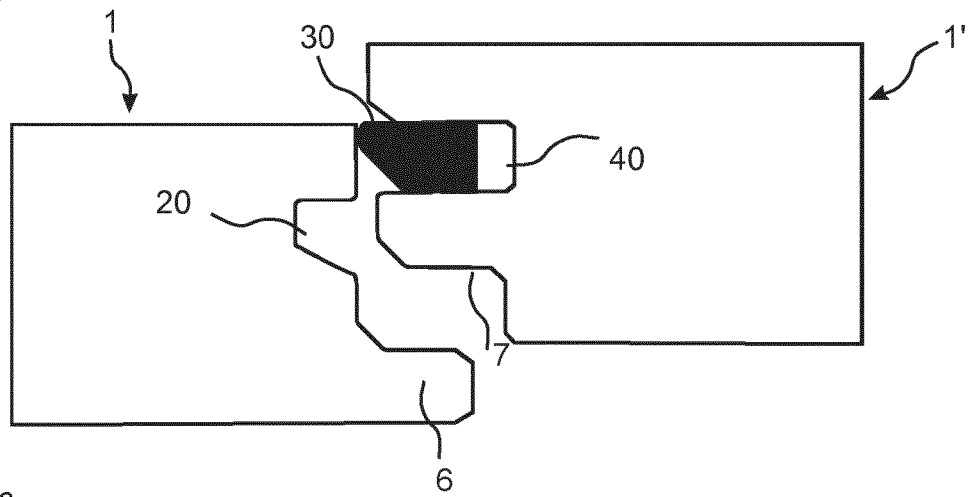

Fig. 4c

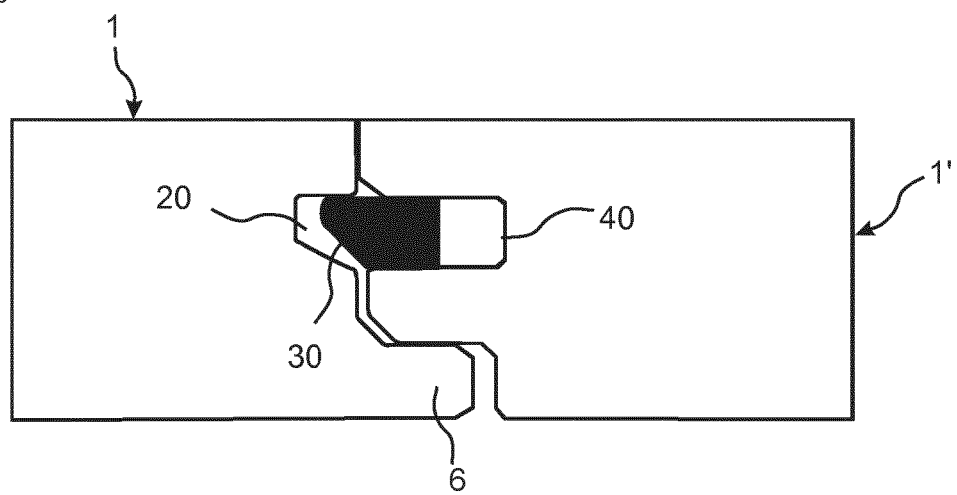

Fig. 5a

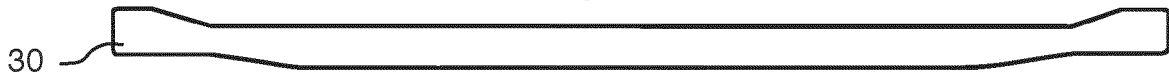

Fig. 5b

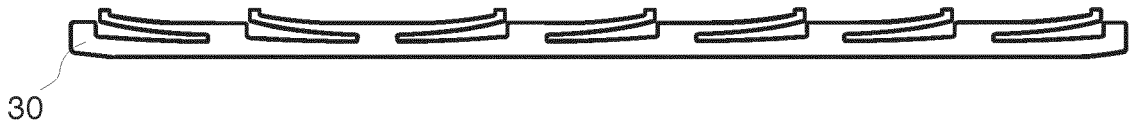

Fig. 5c

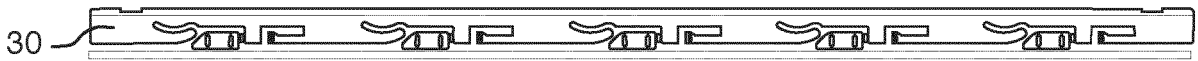

Fig. 5d



Fig. 5e

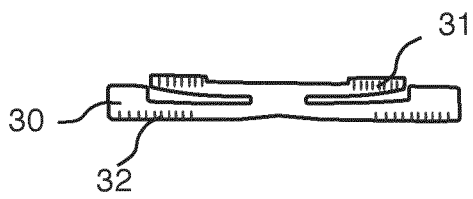

Fig. 5f

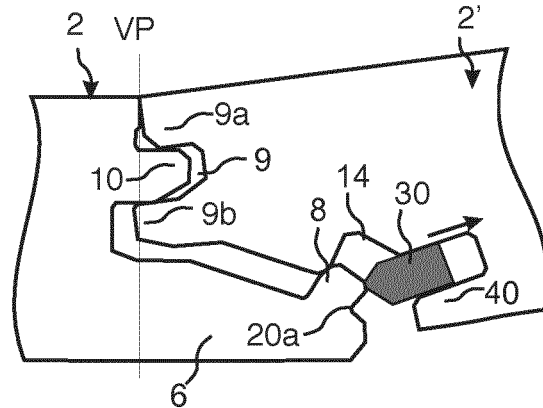

Fig. 6a

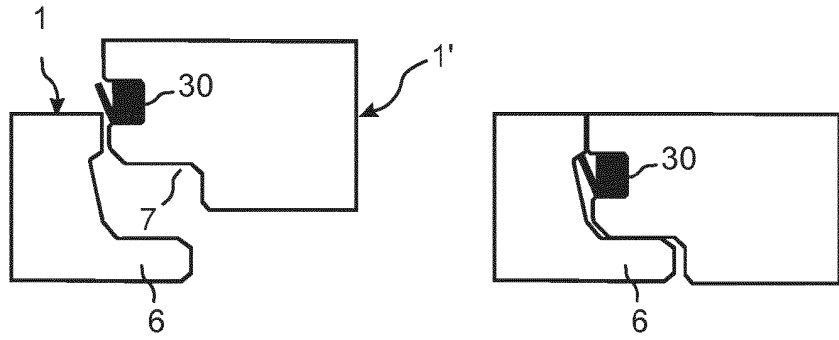

Fig. 6b

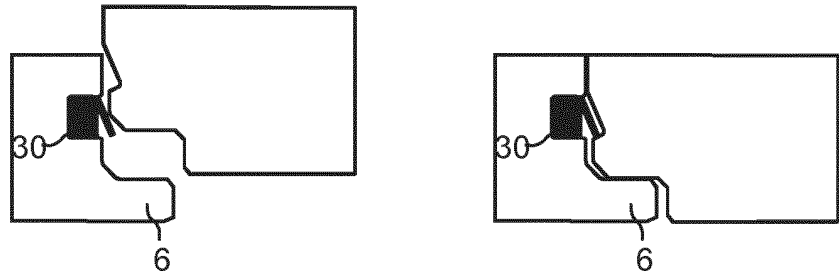

Fig. 6c

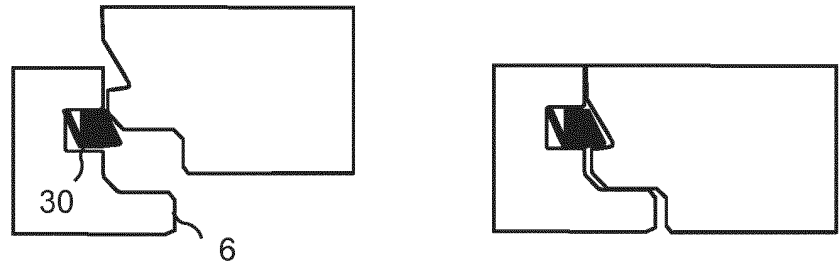

Fig. 6d

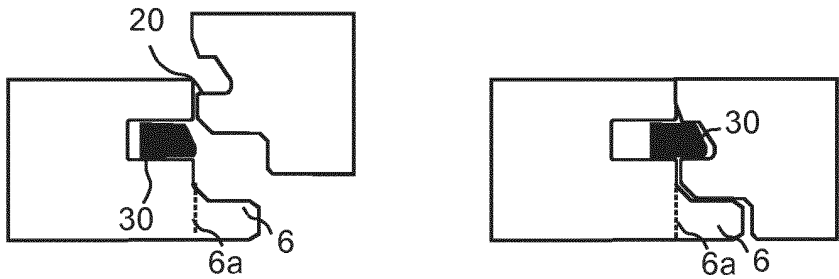

Fig. 6e

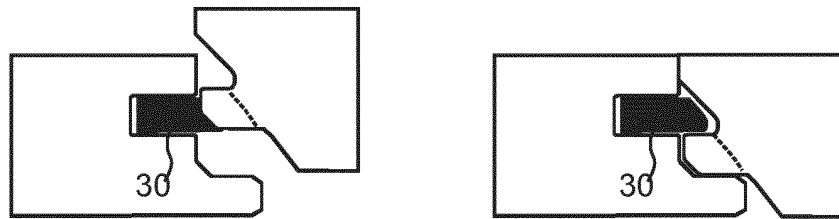

Fig. 6f

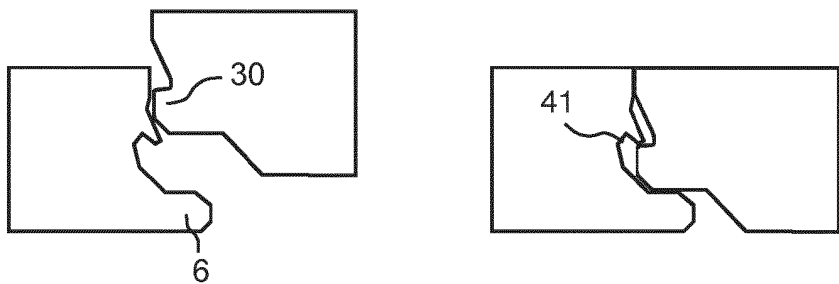

Fig. 7a

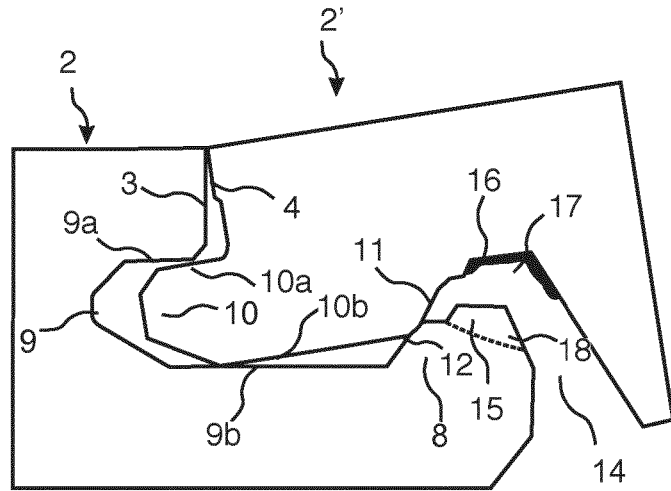

Fig. 7b

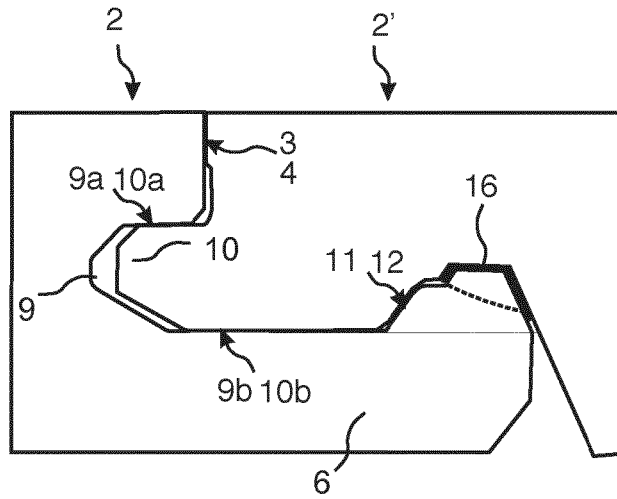

Fig. 7c

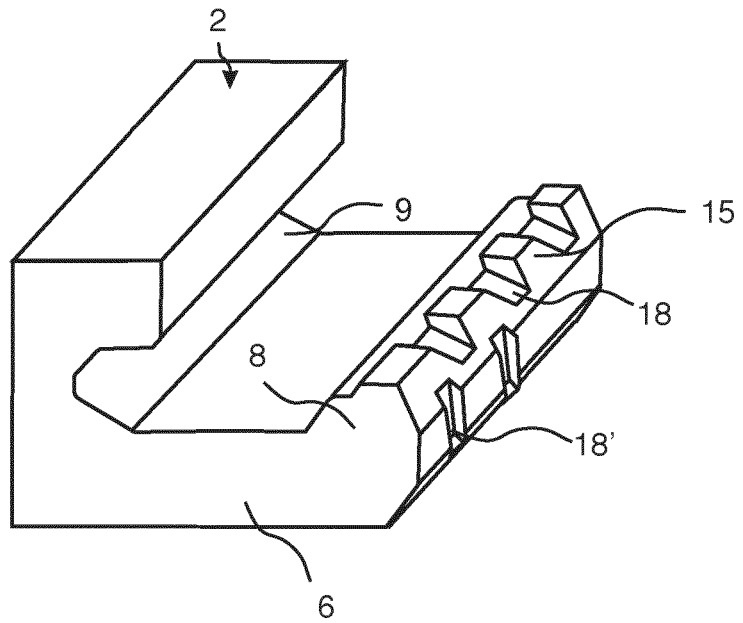

Fig. 8a

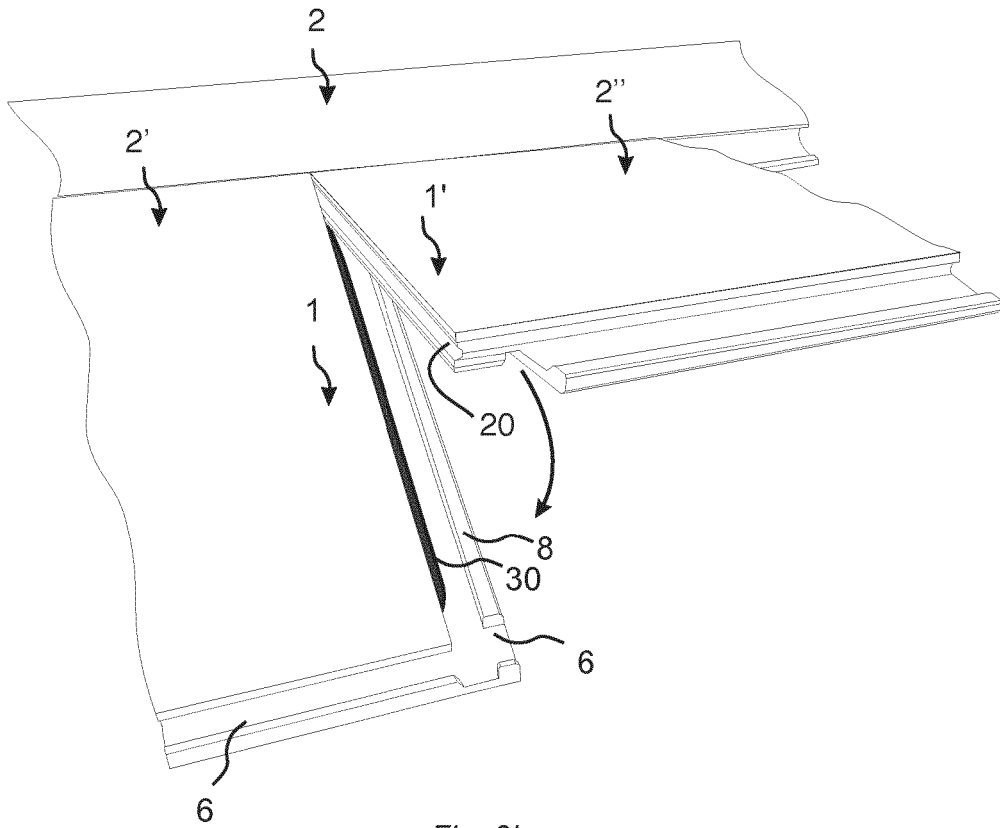

Fig. 8b

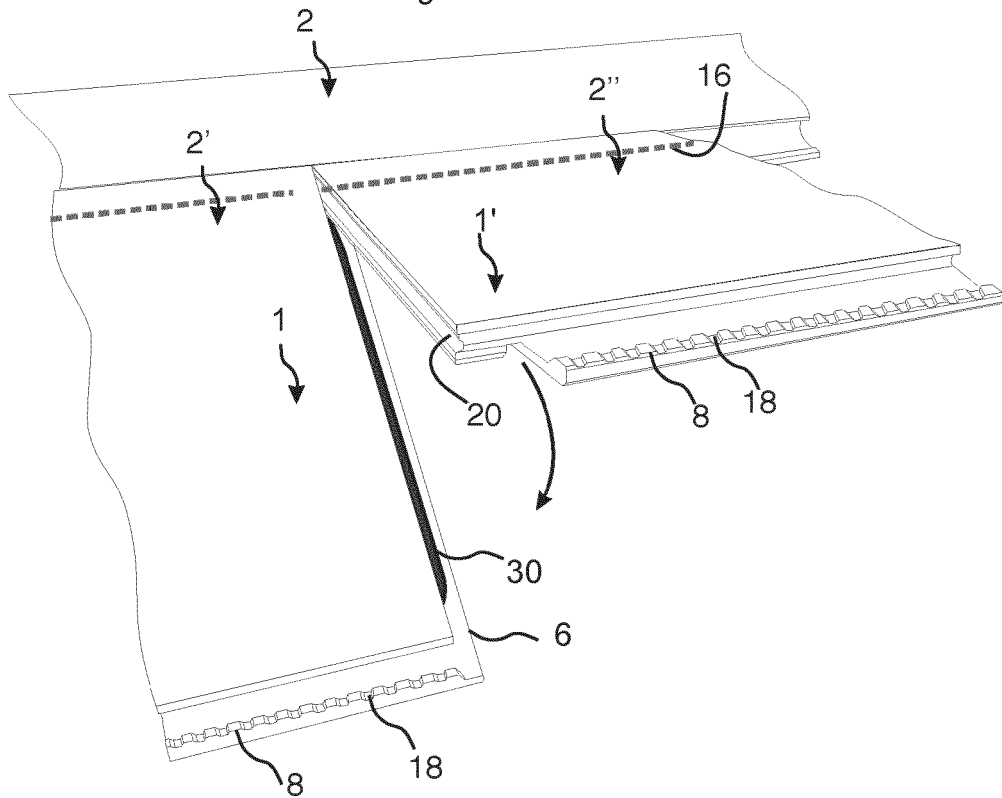

Fig. 9a

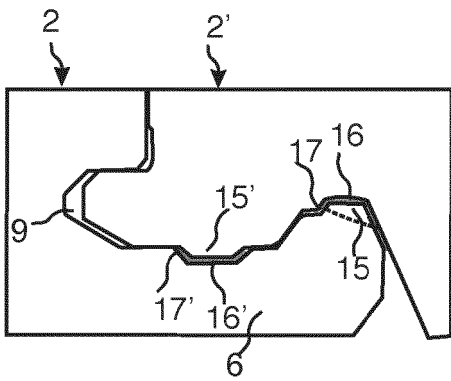

Fig. 9b

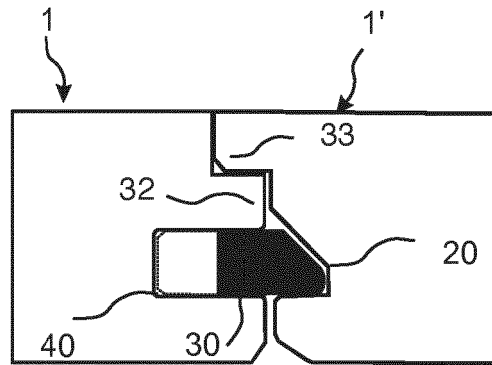

Fig. 9c

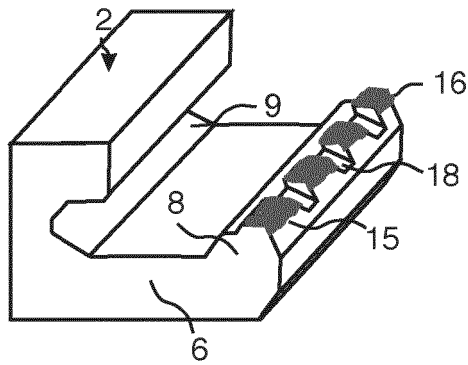
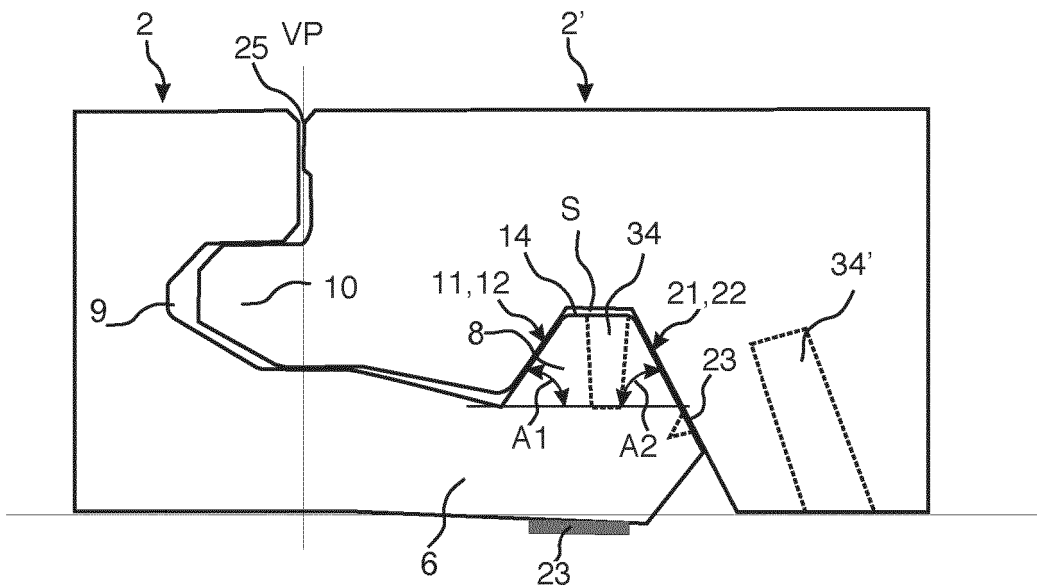

Fig. 9d



REFERENCES CITED IN THE DESCRIPTION

This list of references cited by the applicant is for the reader's convenience only. It does not form part of the European patent document. Even though great care has been taken in compiling the references, errors or omissions cannot be excluded and the EPO disclaims all liability in this regard.

Patent documents cited in the description

- WO 2008060232 A [0011]
- WO 2006043893 A, Välinge Innovation AB [0014]
[0021]
- WO 2006104436 A [0016]
- WO 2007015669 A [0016]
- WO 2008004960 A [0016]
- WO 2010087752 A, Välinge Innovation AB [0016]
[0101]
- US 2430200 A [0024]
- US 4426820 A [0025]
- WO 1994026999 A [0026]
- WO 9822677 A [0027]
- WO 03025307 A [0028]
- WO 03089736 A [0028]
- WO 03012224 A [0028]
- WO 2004083557 A [0029]
- WO 2006123988 A [0030]