

(12) **United States Patent**
Campbell et al.

(10) **Patent No.:** **US 10,983,046 B2**
(45) **Date of Patent:** ***Apr. 20, 2021**

(54) **ENHANCED OPTICAL DATA CAPTURE USING NDIR FOR LIQUIDS**

2021/3148 (2013.01); G01N 2201/10 (2013.01); G01N 2201/127 (2013.01)

(71) Applicant: **Airware, Inc.**, Newbury Park, CA (US)

(58) **Field of Classification Search**
CPC G01N 2021/3148; G01N 21/3577; G01N 2201/10; G01N 2201/127; G01N 33/49
See application file for complete search history.

(72) Inventors: **Thomas G. Campbell**, Newbury Park, CA (US); **Jacob Y Wong**, Goleta, CA (US)

(73) Assignee: **Airware, Inc.**, Goleta, CA (US)

(56) **References Cited**

(*) Notice: Subject to any disclaimer, the term of this patent is extended or adjusted under 35 U.S.C. 154(b) by 0 days.

This patent is subject to a terminal disclaimer.

U.S. PATENT DOCUMENTS

6,067,463 A 5/2000 Jeng et al.
6,509,567 B2* 1/2003 Boudet G01M 3/002 250/343

(Continued)

FOREIGN PATENT DOCUMENTS

CN 1275200 A 11/2000
CN 101263388 A 9/2008
CN 102455286 A 5/2012

OTHER PUBLICATIONS

International Search Report issued in corresponding International Patent Application No. PCT/US2020/023914, dated Apr. 20, 2020 (2 pages).

Primary Examiner — Mark R Gaworecki

(74) *Attorney, Agent, or Firm* — Greenberg Traurig, LLP; Chinh H. Pham; Brian J. Assessor

(21) Appl. No.: **16/600,466**

(22) Filed: **Oct. 12, 2019**

(65) **Prior Publication Data**

US 2020/0150033 A1 May 14, 2020

Related U.S. Application Data

(63) Continuation of application No. 16/359,350, filed on Mar. 20, 2019, now Pat. No. 10,473,586, which is a continuation-in-part of application No. 16/056,531, filed on Aug. 7, 2018, now Pat. No. 10,241,044, which is a continuation-in-part of application No.

(Continued)

(51) **Int. Cl.**

G01N 33/49 (2006.01)
G01N 21/35 (2014.01)
A61B 5/145 (2006.01)
G01N 21/3577 (2014.01)
A61B 5/1455 (2006.01)
G01N 21/31 (2006.01)

(52) **U.S. Cl.**

CPC **G01N 21/3577** (2013.01); **A61B 5/1455** (2013.01); **G01N 33/49** (2013.01); **G01N**

(57) **ABSTRACT**

The concentration of a targeted molecule (such as glucose) in a liquid medium having at least one interfering molecule coexisting with the targeted molecule is detected by use of NDIR and a sampling technique in which an imposed location of a pulse beam from a signal source, an interference source and a reference source is varied over a plurality of sites of a sampling area.

28 Claims, 13 Drawing Sheets

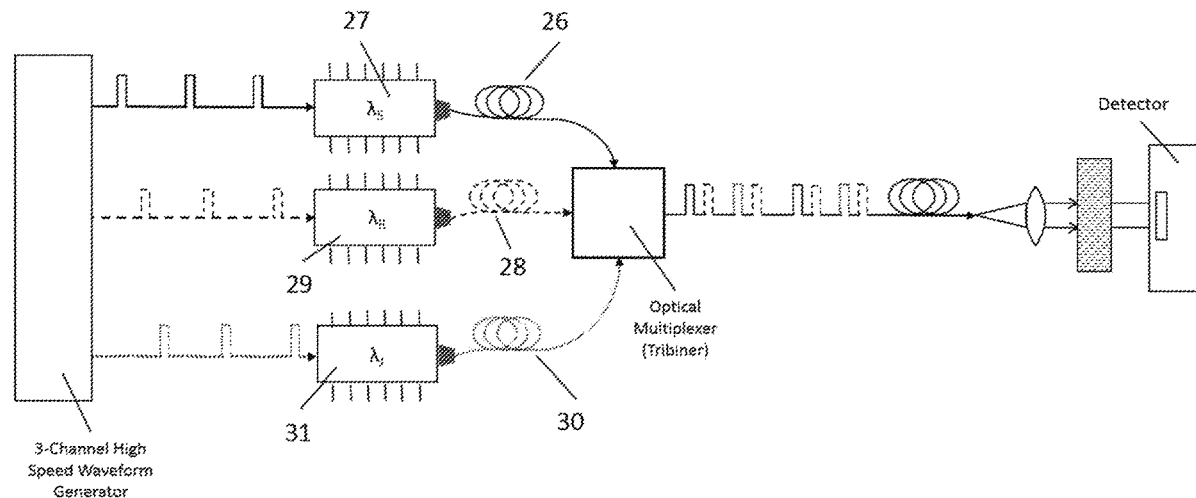

Related U.S. Application Data

15/785,829, filed on Oct. 17, 2017, now Pat. No. 10,041,881, which is a continuation-in-part of application No. 15/644,775, filed on Jul. 8, 2017, now Pat. No. 9,823,185, which is a continuation-in-part of application No. 15/594,418, filed on May 12, 2017, now Pat. No. 9,726,601, which is a continuation-in-part of application No. 15/444,136, filed on Feb. 27, 2017, now Pat. No. 9,678,000, which is a continuation-in-part of application No. 15/358,873, filed on Nov. 22, 2016, now Pat. No. 9,606,053.

(56)

References Cited

U.S. PATENT DOCUMENTS

9,606,053	B1	3/2017	Wong et al.	
9,678,000	B1	6/2017	Wong et al.	
9,726,601	B1	8/2017	Wong et al.	
9,823,185	B1	11/2017	Wong et al.	
10,041,881	B2*	8/2018	Wong	G01N 21/274
10,241,044	B2*	3/2019	Wong	G01N 33/49
10,473,586	B2	11/2019	Campbell et al.	
2005/0012042	A1	1/2005	Weckstrom et al.	
2016/0132617	A1	5/2016	Liu et al.	
2017/0265787	A1	9/2017	Wong	

* cited by examiner

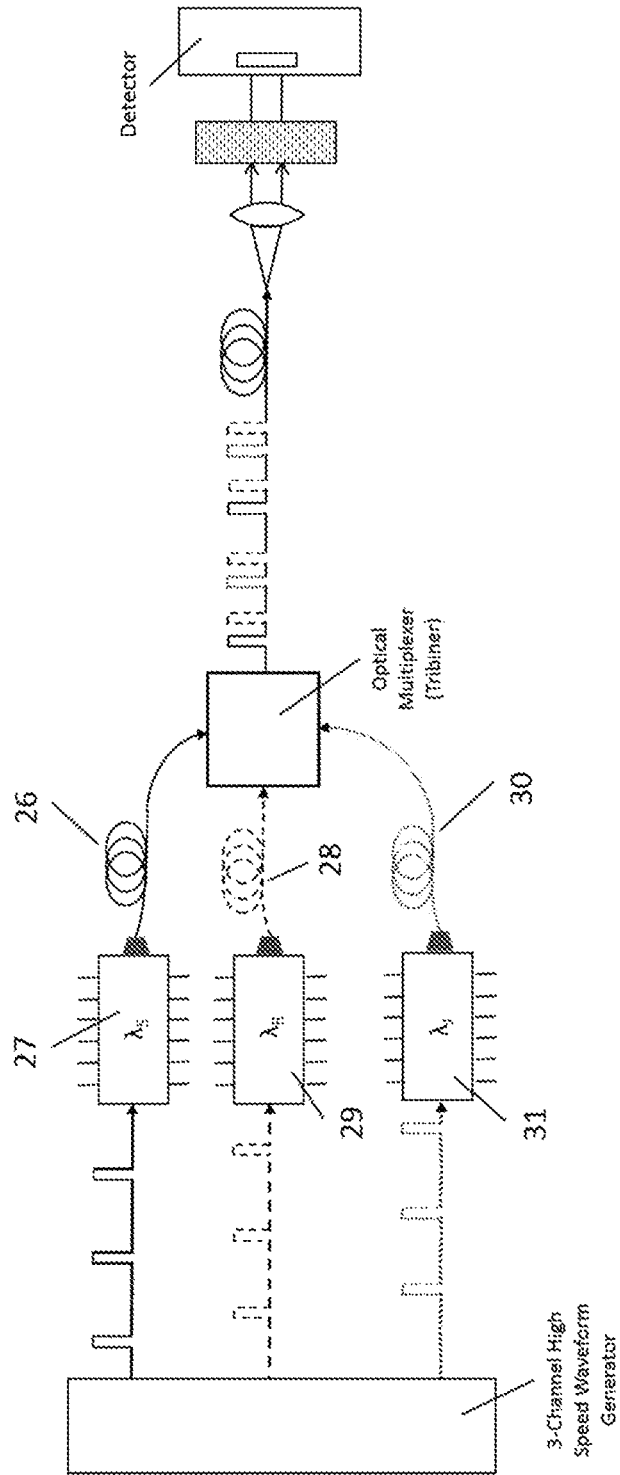

Fig. 1

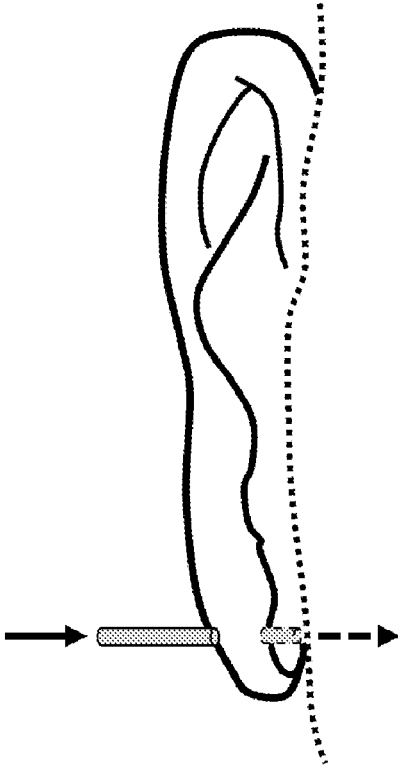

Fig. 2

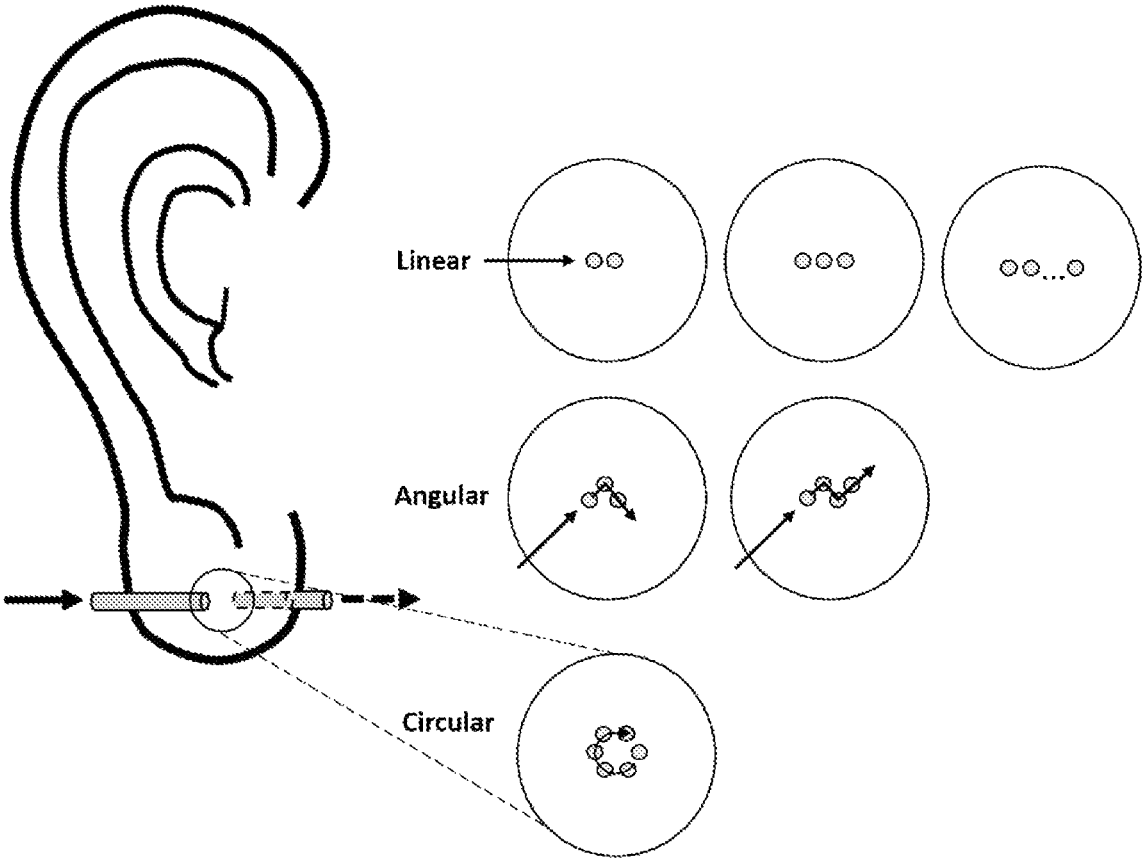

Fig. 3

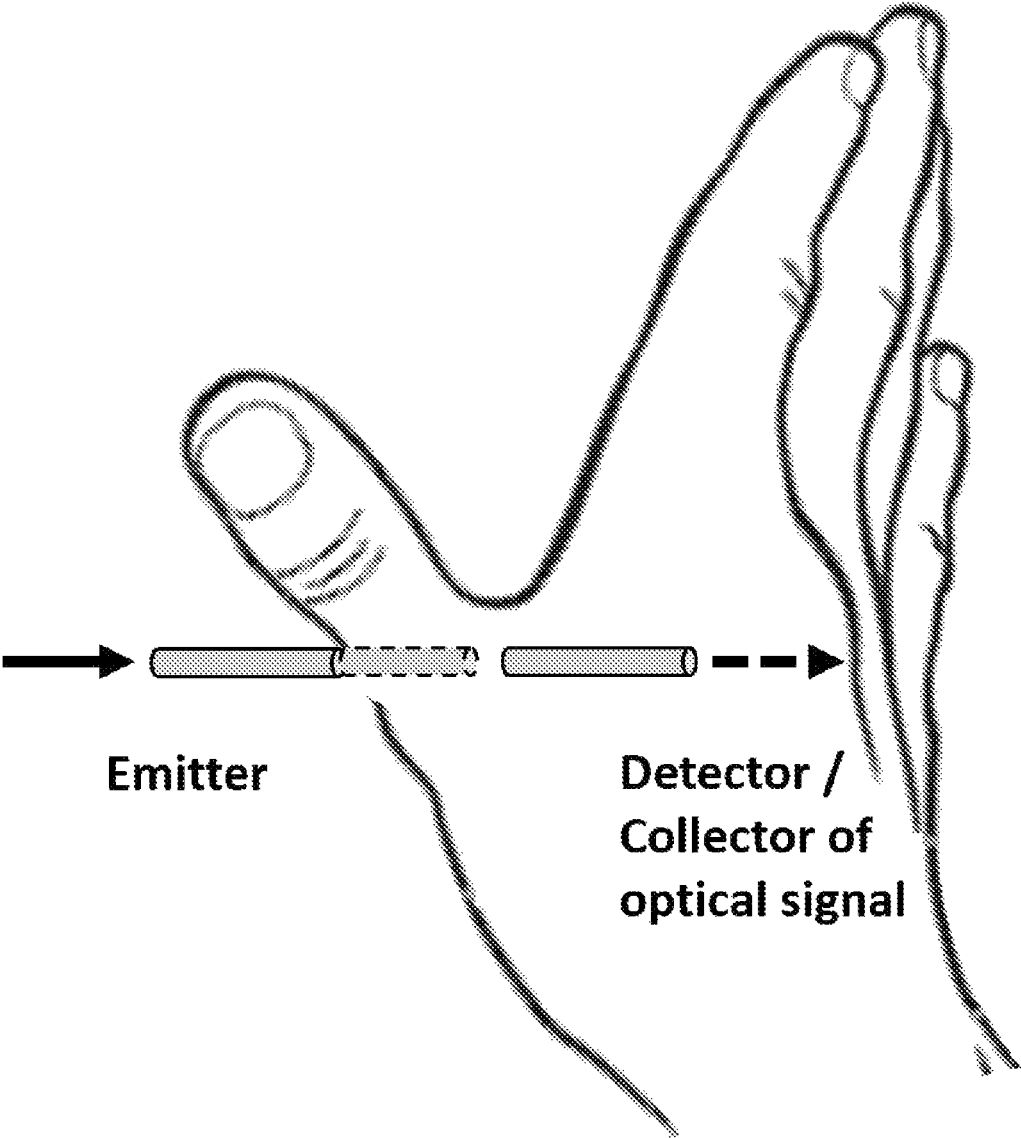

Fig. 4

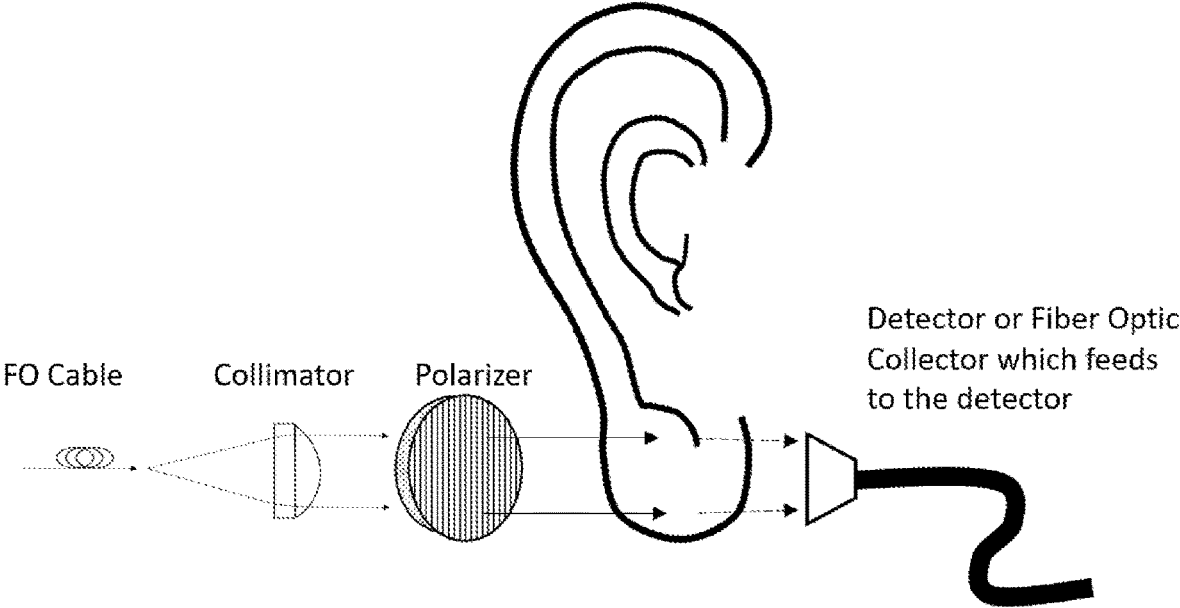

Fig. 5

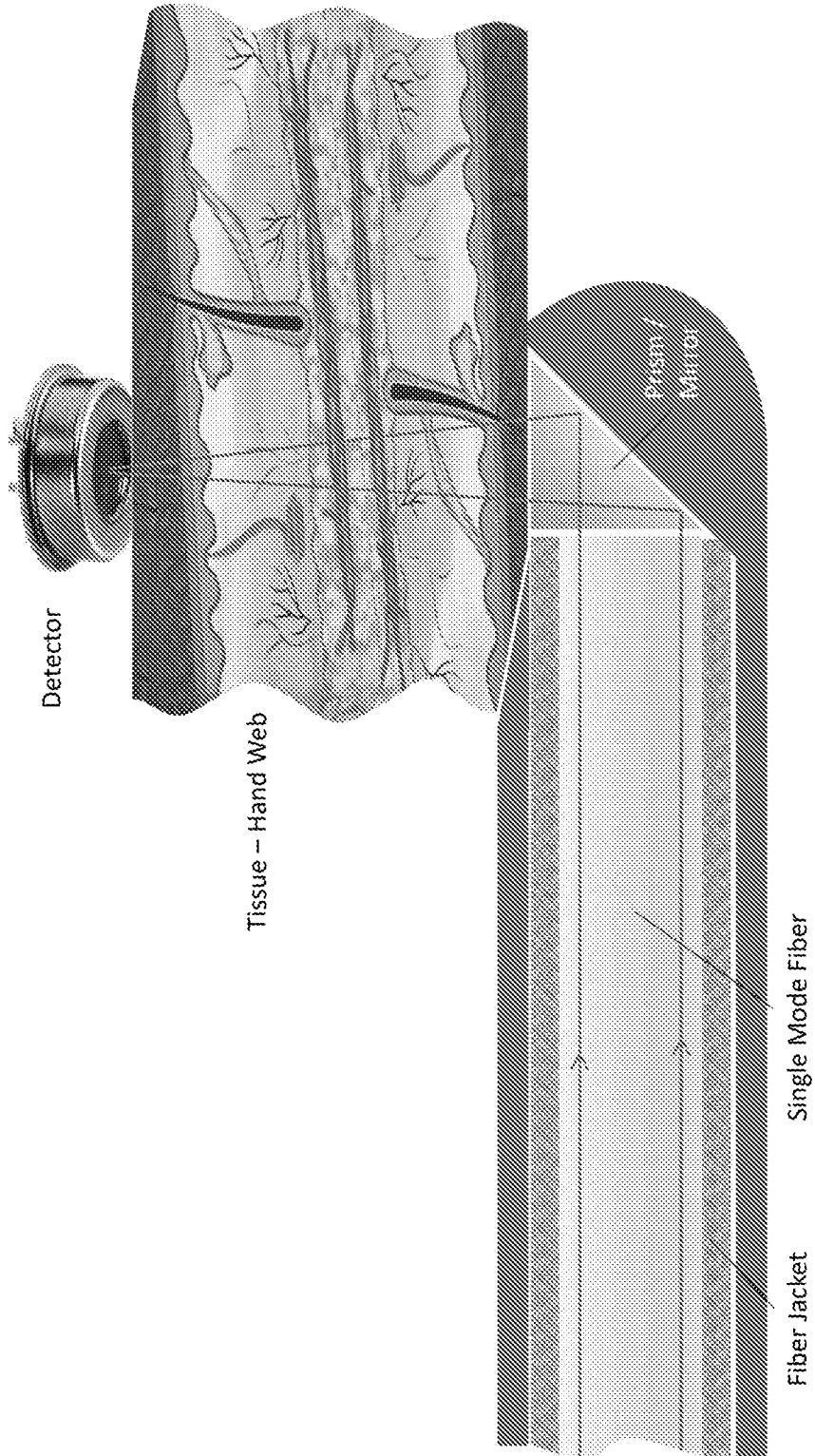

Fig. 6

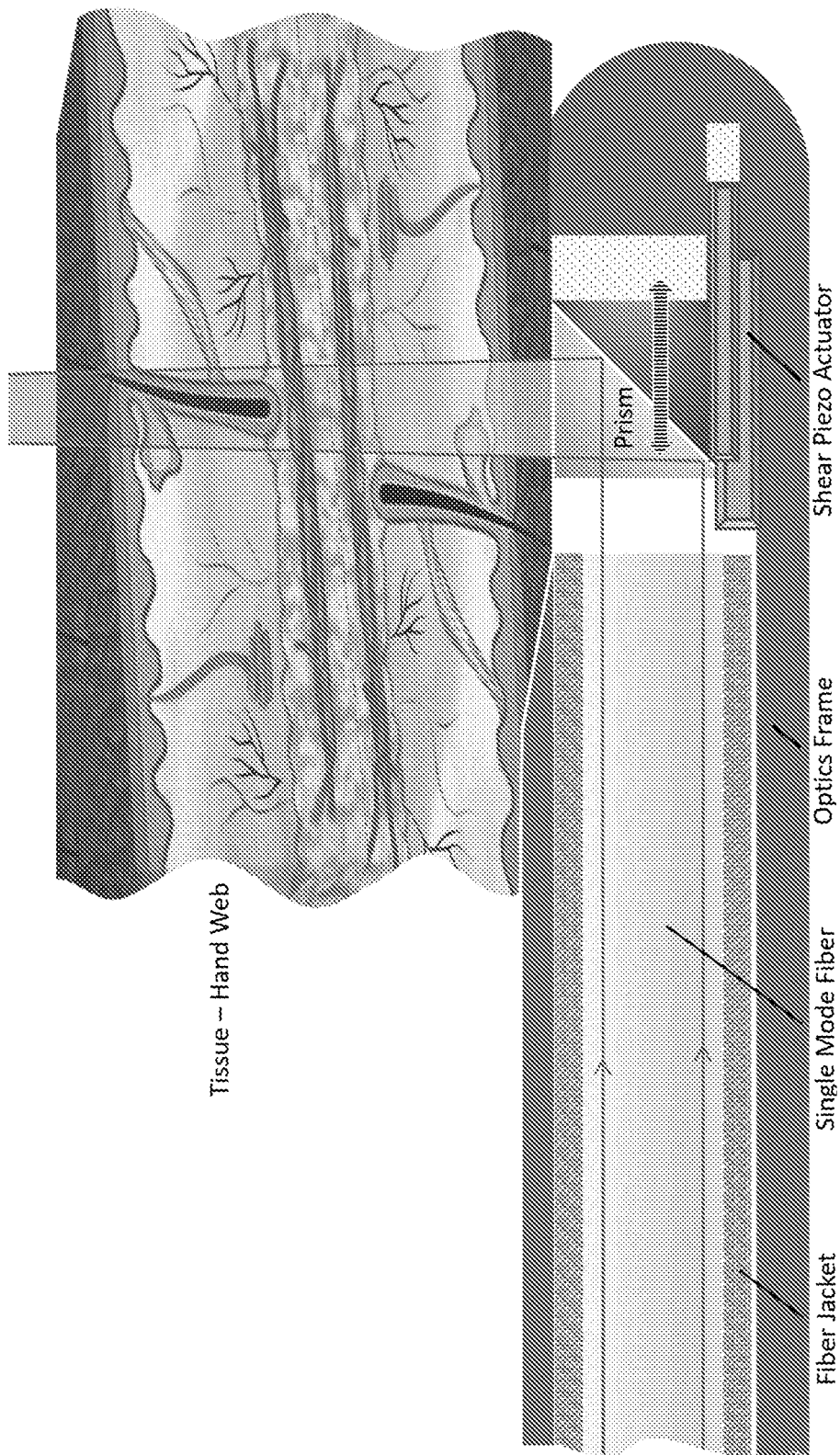

Fig. 7

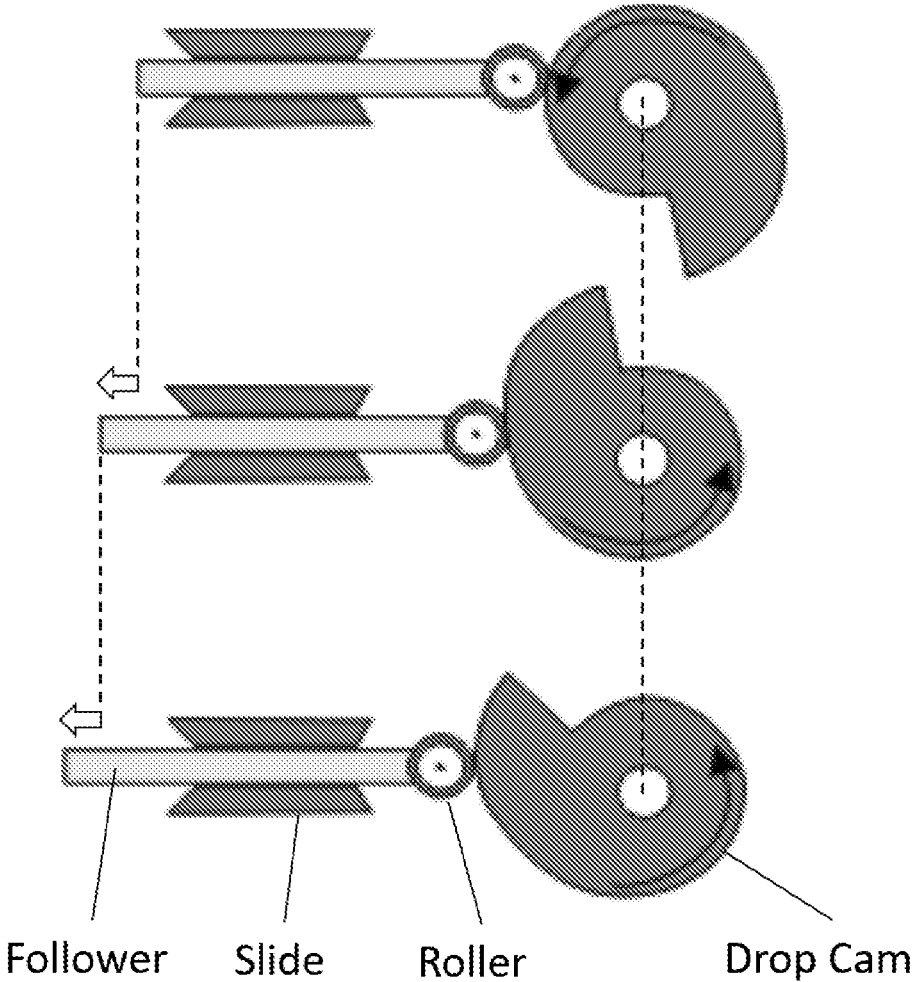
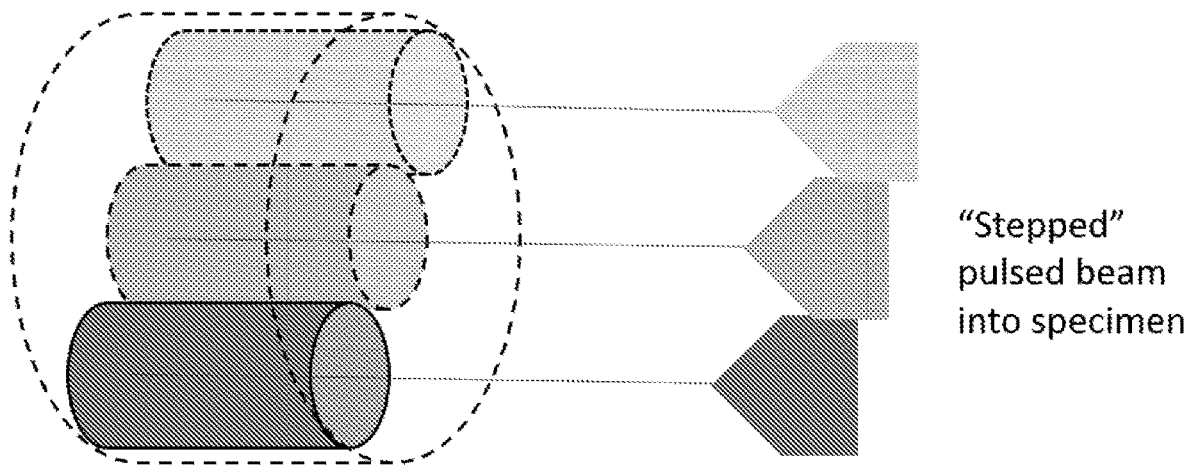

Fig. 8



Constant "illumination volume"
maintained in test specimen

Fig. 9

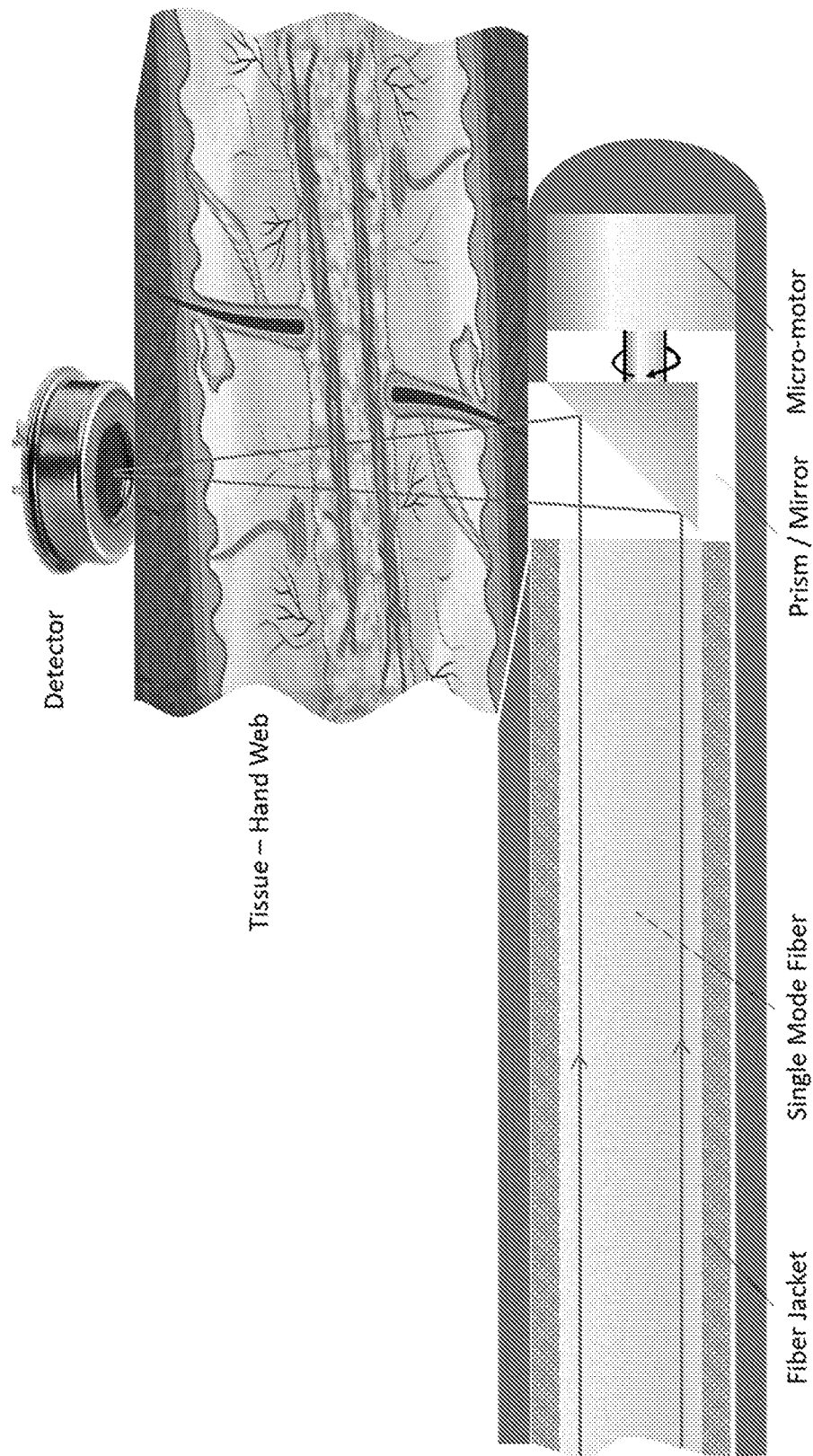

Fig. 10

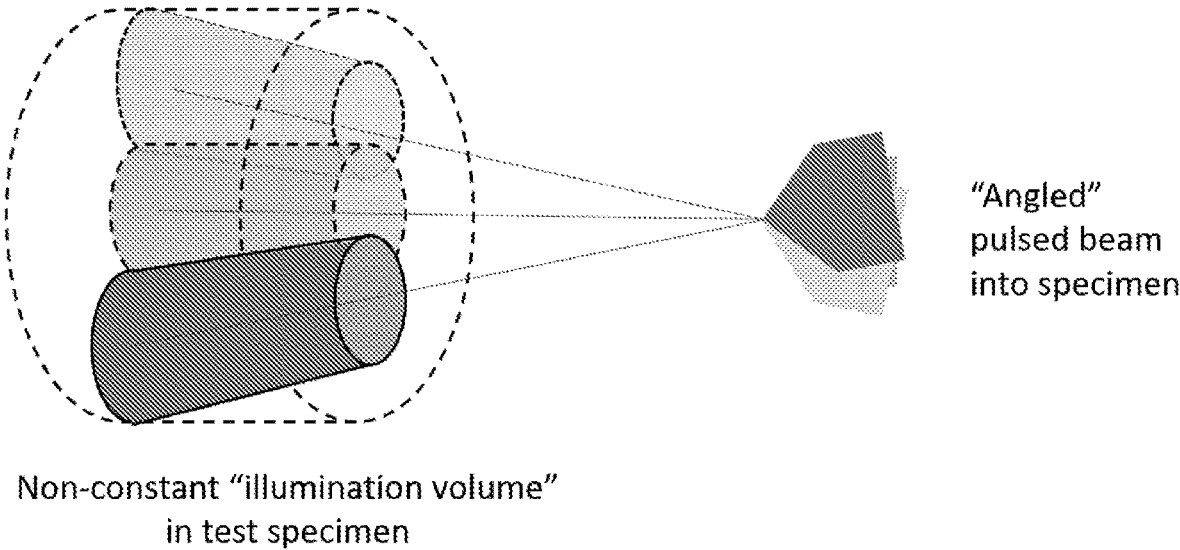

Fig. 11

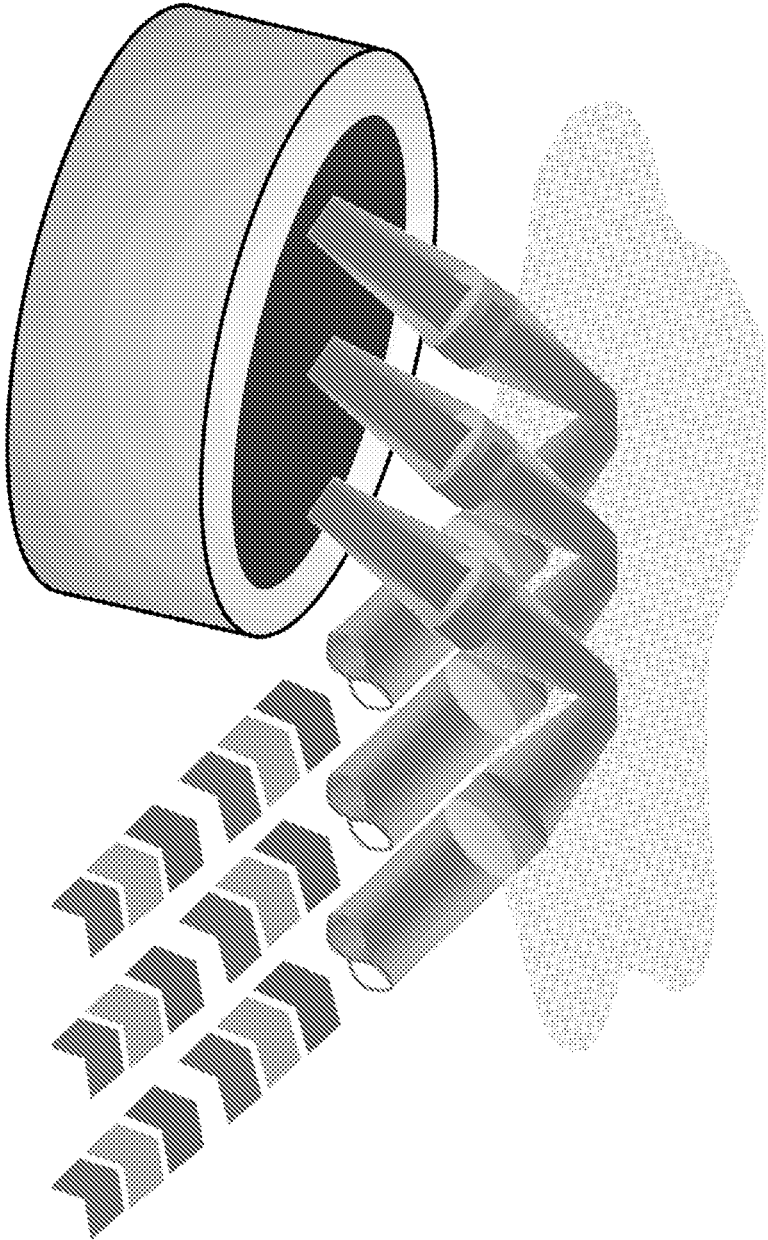

Fig. 12

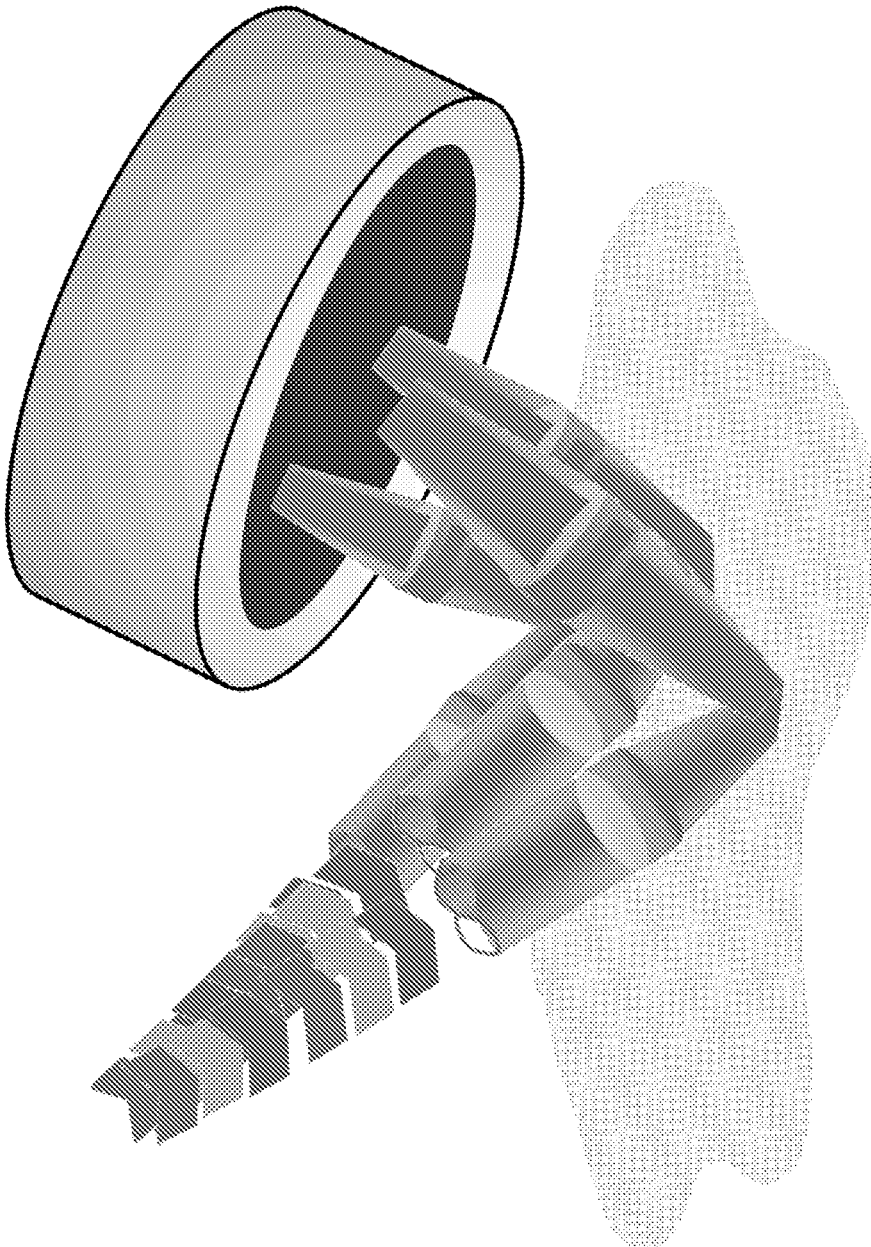

Fig. 13

ENHANCED OPTICAL DATA CAPTURE USING NDIR FOR LIQUIDS

CROSS-REFERENCE TO RELATED APPLICATIONS

The present invention is a continuation of U.S. Ser. No. 16/359,350, filed Mar. 20, 2019, which is a continuation-in-part application of U.S. Ser. No. 16/056,531, filed Aug. 7, 2018, which is a continuation-in-part of U.S. Ser. No. 15/785,829 filed Oct. 17, 2017, which was issued on Aug. 7, 2018 as U.S. Pat. No. 10,041,881, which is a continuation-in-part of U.S. Ser. No. 15/644,775 filed Jul. 8, 2017, which was issued on Nov. 21, 2017 as U.S. Pat. No. 9,823,185, which is a continuation in part of U.S. Ser. No. 15/594,418 filed May 12, 2017, which was issued on Aug. 8, 2017 as U.S. Pat. No. 9,726,601, which is a continuation-in-part application of U.S. Ser. No. 15/444,136 filed Feb. 27, 2017, which was issued on Jun. 13, 2017 as U.S. Pat. No. 9,678,000, which is a continuation-in-part application of U.S. Ser. No. 15/358,873, filed Nov. 22, 2016, which was issued on Mar. 28, 2017 as U.S. Pat. No. 9,606,053, the disclosures of all of which are specifically incorporated herein by reference.

FIELD OF THE INVENTION

The present invention relates to an improved Non-Dispersive Infra-Red (NDIR) absorption method to detect molecules in the liquid phase.

BACKGROUND OF THE INVENTION

Non-Dispersive Infra-Red (NDIR) is a common and excellent measurement technique for detecting gases in the atmosphere. NDIR sensors utilize the principle that various gas molecules exhibit substantial absorption at specific wavelengths in the infrared radiation spectrum. The term "non-dispersive" as used herein refers to the apparatus used, typically a narrow-band optical or infrared transmission filter, instead of a dispersive element such as a prism or diffraction grating. The optical filter isolates the radiation in a particular wavelength band that coincides with a strong absorption band of a gas species for the purpose of said gas species measurement.

The present invention builds upon past inventions disclosed in related applications to further advance use of NDIR to detect molecules in a liquid medium.

This and further objects and advantages will be apparent to those skilled in the art in connection with the figures and the detailed description of the invention set forth below.

SUMMARY OF THE INVENTION

The present invention is generally directed to a process and apparatus useful for determining a concentration of a targeted molecule M (such as glucose) within a given time period in a liquid sampling matrix in which at least one interfering molecule M_j coexists with the targeted molecule. A multiplexer and a collimator are configured to pulse infrared radiation from a signal source, an interference source and a reference source into a pulsed beam which is directed at a first inclined angle (θ_{i1}) to a normal of a first spot of the liquid sampling matrix. A detector is configured to detect infrared radiation after it emerges from the first spot as a first pulsed signal and reference channel output and a first pulsed interference signal and reference channel output

from the pulsed beam after it penetrates into the spot. The imposed location of the pulsed beam is changed so that it is directed at a second inclined angle (θ_{i2}) to a normal of a second spot of the liquid sampling matrix and the detector is configured to detect infrared radiation after it emerges from the second spot as a second pulsed signal and reference channel output and a second pulsed interference signal and reference channel output from the pulsed beam after it penetrates into the second spot. The imposed location of the pulsed beam can be changed without changing the physical location of either the pulsed beam or the detector by use of an optical device which itself can be moved by a piezo/electronic, electronic, magnetic or mechanical means; alternatively, the physical location of the pulsed beam and/or the detector can be changed. Signal processing is provided for: (1) obtaining a first average ratio value of $R_{ave}(t_1)$ for a first preselected period of time (" t_1 ") from the first pulsed signal and reference channel output, where $R_{ave}(t_1)$ =signal channel/reference channel output for the first preselected period of time; (2) obtaining a first average ratio value of $R_{Jave}(t_2)$ for a second preselected period of time (" t_2 ") from the first pulsed interference and reference channel output, where $R_{Jave}(t_2)$ =interference channel/reference channel output for the second preselected period of time; (3) obtaining a second average ratio value of $R_{ave}(t_3)$ for a third preselected period of time (" t_3 ") from the second pulsed signal and reference channel output, where $R_{ave}(t_3)$ =signal channel/reference channel output for the third preselected period of time; and (4) obtaining a second average ratio value of $R_{Jave}(t_4)$ for a fourth preselected period of time (" t_4 ") from the second pulsed interference and reference channel output, where $R_{Jave}(t_4)$ =interference channel/reference channel output for the fourth preselected period of time. Electronics are configured to use $R_{Jave}(t_2)$ and $R_{Jave}(t_4)$ to determine that a calibration curve is valid for the given time period and, if the calibration curve is valid, to calculate the concentration of the targeted molecule M in the liquid sampling matrix by use of $R_{ave}(t_1)$, $R_{ave}(t_3)$ and the calibration curve and provide the concentration of the targeted molecule M in the liquid sampling matrix as an output.

The object of the present invention is to provide an improved system and process for detection of molecules in a liquid medium using NDIR and a sampling technique in which an imposed location of a pulse beam is varied.

This and further objects and advantages will be apparent to those skilled in the art in connection with the figures and the detailed description of the invention set forth below.

BRIEF DESCRIPTION OF THE DRAWINGS

FIG. 1 illustrates an optical setup illustrating how a Signal diode laser, a Reference diode laser and an Interference diode laser are driven alternatively and successively by a 3-channel high speed waveform generator.

FIG. 2 is a side view which illustrates a pulsed beam as it passes through a liquid medium of an earlobe.

FIG. 3 is a front view of FIG. 2 and includes details of six different spot patterns for three options of multi-site scanning patterns: linear, non-linear, and circular.

FIG. 4 illustrates a pulsed beam as it passes through a liquid medium of a handweb.

FIG. 5 illustrates a concept showing how polarized light is collected to feed a detector and incorporated into the present invention.

FIG. 6 illustrates a pulsed beam according to the present invention being delivered by way of a single mode optical fiber to a prism or mirror such that the profile is kept low and

the controlled light beam can enter the specimen or media under test and transverse the specimen or media in the direction of a detector system that can capture the exiting light energy.

FIG. 7 illustrates the concept of using rotational motion to create a linear scan path by implementation of a rotary drop cam system illustrated in FIG. 8.

FIG. 9 illustrates multiple scan sites with a linear scan pattern where each separate scan site comprises a constant volume for equivalent and optimum data capture and comparison analysis.

FIG. 10 illustrates one possible method of using rotational motion to establish a scan range of the specimen or media under test by use of a rotating actuator a mirror or some element to redirect the pulsed beam in a precise and consistent fashion.

FIG. 11 demonstrates that adding any angularity to the progressive scanning method creates slightly different volumes illuminated in the specimen or media under test.

FIG. 12 illustrates using the pulsed beam in accordance with the present invention in a reflective approach to the specimen or media under test. Portrayed is a linear scan step pattern such that each illumination site is identical in illumination area leading to near-identical data capture at the detector.

FIG. 13 is another proposed reflective scanning pattern where the illuminating beam is angled in order to gather data from two or more scan sites. The angled beams create slightly different scan site areas (such that the data collected at the detector must be adjusted to account for these variations.)

DETAILED DESCRIPTION OF THE INVENTION

U.S. Pat. No. 9,606,053 (2017) discloses an NDIR method which significantly suppresses scattering noise attributable to the much higher molecular density which is encountered in a liquid medium, as opposed to a gaseous medium. The method utilizes alternating and successively pulsing infrared radiation from signal and reference sources which are multiplexed and collimated into a single pulsed beam directed through the liquid sample. The pulse frequency is set sufficiently fast so as to provide almost the same molecular configuration to both the signal and the reference beams. The scattering noise encountered by both beams is effectively the same and can be significantly reduced through processing the ratio of their respective pass-through outputs.

U.S. Pat. No. 9,678,000 (2017) discloses using an NDIR method to detect glucose in a liquid medium. Glucose has an overtone absorption band located at 1,150 nm which can be used as the center wavelength for the signal beam. This absorption band is desirable because it has a water absorption coefficient of no greater than $\sim 1.0 \text{ cm}^{-1}$, which is especially preferred, as it helps to minimize effects created by water absorption. A reference beam wavelength of 1,064 nm, where there is no glucose molecule absorption, can be used as the center wavelength for the reference beam.

U.S. Pat. No. 9,726,601 (2017) discloses an improved NDIR method for determining the concentration of targeted molecules labeled M in a liquid medium admixed with interfering molecules labeled M_I which uses an additional interference radiation source besides those of the signal and reference to significantly reduce the interference noise. U.S. Pat. No. 9,823,185 (2017) discloses an improvement to this

method with suppression of both scattering and absorption interference noise (AIN) via a reflection detection technique.

The present invention utilizes a signal source, an interference source, a reference source, a multiplexer and a collimator to pulse radiation in a pulsed beam which is detected by a detector as is described in greater detail in U.S. Pat. Nos. 9,606,053 and 9,823,185. The signal source emits radiation at a signal wavelength which is within a first absorption band of the targeted molecule M, the interference source emits radiation at an interference wavelength which is within a second absorption band of said at least one interfering molecule M_I , and the reference beam emits radiation at a reference wavelength which is neutral and is not within either the first absorption band or the second absorption band; at least one interfering molecule M_I absorbs radiation at the signal wavelength; and the signal source, the interference source and the reference source are each pulsed at a preselected frequency of at least N Hz which is sufficiently fast so that a given molecule of the targeted molecule M or said at least one interfering molecule M_I will not pass in and out of the liquid sampling matrix within the preselected frequency.

FIG. 1 (which is FIG. 8 in U.S. Pat. No. 9,823,185) illustrates an optical setup of a Signal diode laser, a Reference diode laser and an Interference diode laser which are driven alternately and successively in groups of two by a 3-channel high speed waveform generator. As shown in FIG. 1, output 26 of Signal diode laser 27 is driven alternately and successively with output 28 of Reference diode laser 29 as a pair; meanwhile output 30 of Interference diode laser 31 is driven alternately and successively with output 28 of Reference diode laser 29 as another pair. The rest of the optical and electronic processing system setup for a three-diode laser system to suppress both scattering noise and AIN is the same as the two-diode laser system disclosed in U.S. Pat. No. 9,606,053 (2017) for suppressing just the scattering noise.

U.S. Pat. No. 10,041,881 (2018) discloses an improved NDIR method for liquids in which scattering noise is reduced and an Absorption Interference Noise (AIN) is suppressed with a reflection technique.

U.S. Ser. No. 16/056,531 discloses a process for deciding the validity of the calibration curve for targeted molecules M_G in a liquid sample with interfering molecules. This value can further be used to adjust the calibration curve via a parameter linking the transmittances measured at the signal and interference wavelength channels in order to assure its validity.

A potential limitation of the techniques described in our earlier patents for optical sensing in liquids is a very small sample volume per measurement. In order to enhance the accuracy, precision and reliability of measurements with our inventive Direct Infrared Laser Absorptive Scattering Technique (DILAST) sensors, the present invention incorporates different sample capture techniques.

DILAST optical sensing for liquids can be applied to containerized samples, fluid flows, semi-solid materials, and solid materials all of which have optical permeability such that optical wavelengths can penetrate to some level that allows absorption of target elements or compounds so that detector measurements can be made of said absorption.

For the embodiment of sensing in human tissue, which for the purpose of the present invention will be defined as being a liquid medium which has a dynamic volume with considerable molecular motion incorporating a non-homogenous structure. Many elements and compounds comprise skin with arrangements according to their functions. Knowing

that DILAST sensor systems have to work with these complex samples, the present invention sets forth several methods for improving optical sensor data capture from such samples.

Of the various elements affecting optical absorption in skin, water is the primary absorber by volume. Accounting for hydration of the skin is necessary for highest detection accuracy of glucose in interstitial fluid. Next are various lipids including adipose tissue in skin, followed by melanin in the epidermis, then white blood cells and red blood cells (oxygenated and de-oxygenated) in arteries, veins, and capillaries. Lastly, we step down in volume to proteins, and glucose.

Minimization of the total optical energy imposed on skin is important to the functioning of the DILAST technique. Very specific reference and target species wavelengths are employed to accomplish scattering noise cancellation technique according to the present invention. And beyond the controlled wavelengths, the present invention employs a “relatively” small “beam” of optical energy whose resulting scattering and absorption effects are captured on “relatively” small detectors as shown in one configuration described by FIG. 6.

As data manipulation techniques improve with time, one may be able to employ larger beams and be able to process out the larger noise factors. With larger beams, one naturally captures a large sample volume which promotes the goal of high accuracy, precision, and reliability of measurements. However, if one is using a “relatively” small beam, one needs to, in some fashion, scan this beam across a “sample” such that one truly captures a representative data set of the non-homogenous “sample,” and such scanning can be linear, circular, or some combination or hybrid motion such that during the set measurement time, a “comprehensive” data set is captured for calculating values and averaging those values across said “comprehensive” data set. If the samples obtained are not of constant volume, it is especially preferred that non-constant volume illumination must be addressed in the analysis of the data captured to correct for the effects of either larger or smaller “illumination volumes”.

Mechanics of the scanning motion according to the present invention can be implemented with a linear, circular, or combination of linear and circular that best includes a suitable sample volume and subsequent suitable data set, and methods for linear, circular, or hybrid travel can be implemented with electronic, magnetic, or pressure forces. The goal with implementation is smallest size and cost to accomplish the necessary range of motion for a suitable set of scan sites.

One preferred embodiment for implementing scanning motion according to the present invention is to employ a piezo linear or rotary motor which offers high precision and repeatable positioning. There are many other motor elements that can be employed as well. FIG. 7 represents one implementation of a linear motor moving a mirror in a back and forth motion to obtain a linear scan pattern such that the scan sites are identical in volume. FIG. 8 represents the implementation of a rotary motion source to create a linear motion that likewise can move a mirror for stepping a beam across more than one scan sites.

The next step is choosing whether to apply the motion to just the emitter and/or emitter beam and scan across the detector or move the emitter and detector in tandem. The first requires that the detector area is suitable large as to capture data as the emitter and/or emitter beam travels. The second option allows the detector area to remain small and

cost-effective, but implementing the tandem travel of the emitter and the detector is more complex.

One embodiment of scanning can be accomplished with a small linear actuator moving a mirror element such that the emitter beam is scanned across multiple sample sites on the test sample or specimen.

A shear piezo actuator can linearly move a prism and beam across a scan zone. This scan zone portrayed in FIG. 9 is limited to the available detector area. Multiple sample sites are illuminated for some typical dwell time at each of the three sites in or on the tissue. As noted, the detector area must be sufficiently large to capture reflected and transmitted optical signals. With this technique, a more comprehensive sample is obtained of the tissue that includes interstitial fluid, tissue types, veins, capillaries, follicles, nerves, etc.

Another embodiment shown in FIG. 10 uses a rotary element to step the mirror element such that the single beam is directed onto the detector through separate pathways through the sample.

With a goal of ideal optical data capture from skin, one embodiment incorporates three or more illumination locations in the skin by simply moving the light beam and not the detector. The optics to move the light beam are smaller and more precise than moving the detector housing. The detector will require a sufficient surface area to receive energy from each of the scan sites. The use of a mirror should retain properties of the light beam better than a lens system. The actuator choice for moving the mirror should be precise, repeatable, small, and low power.

The scan zone portrayed in FIG. 11 is likewise limited to the available detector area, however, the scan volumes resulting from the angled beams are slightly different. Therefore, the “detected” results must be interpreted to allow for the slightly different reflection, absorption, transmission, and scattering results captured.

An import aspect of the inventive optical detection method is the application can be in both a transmissive approach as well as a reflective approach. Employing a reflective illumination data gathering method increases options for scanning configurations. With respect to the human body, transmission scanning is limited to certain accessible areas on the body such as the handweb, earlobe, nostril, cheek, eyelid, or fingers and toes, whereas reflective scanning expands typical locations on the human body to include the wrist, upper arm, abdomen, lower back, thigh, and calf as to where a sensor can be attached or worn for both spot and continuous monitoring. FIGS. 12 and 13 illustrate using the pulsed beam in accordance with the present invention in a reflective approach to the specimen or media under test. Both linear scan steps as well as angular scan patterns can be exercised for reflective data collection. As noted, with linear scan stepping, each illumination site is identical in illumination area leading to near-identical data capture at the detector as in FIG. 12. Another proposed reflective scanning pattern where the illuminating beam is angled in order to gather data from two or more scan sites is portrayed in FIG. 13. The angled beams create slightly different scan site areas (such that the data collected at the detector must be adjusted to account for these variations.)

The following is a set of parameters of the scanning pattern and hardware for especially preferred embodiments of the present embodiment: Range of motion: 1-3 mm with step-and-settle times plan of <1 ms to <1 second (depending on data capture); Pattern of motion: linear or arc, linear precision <0.01 mm or angular precision of <1 mrad; System volume: small as possible; Actuation: piezo-linear or motor-rotary; Very low power, battery operated; Ability to return to

set position and hold; Robustness for surviving temperature, shock, and humidity in field use; Embedded controller for ease of system integration.

Each "scan column" with the time-based narrow band spectroscopy sees a matrix of skin components. By moving the "scan column", data capture ensures a comprehensive inclusion of more skin conditions yielding better averaged values of glucose in interstitial fluid for each measurement "set."

One option of creating this emitter housing is with photo-definable glass-ceramics, machining of a metal or plastic, or by injection molding the housing.

The inventive concepts already described herein can be applied to a wearable device using a reflection technique or be used in a device that can, in essence, be clipped on to a suitable portion of the human body, examples of which include a handweb or earlobe, which are illustrated in FIGS. 2 and 4, respectively. If a clip-on type device is desired, it may be beneficial to also use a fiber optic collector, or some other collection device, which serves to make the skin clamp device smaller and lighter, may enable increasing the sample collection area and may serve to concentrate the collected optical data allowing use of a smaller detector element. It might also be desirable to use polarized light because it may enhance absorption by glucose molecules and/or it may help to prevent absorption by other compounds in skin. Different types of light polarization might be implemented to achieve optimum absorption and minimized scattering, so linear and/or circular polarization might enhance overall accuracy, precision, and reliability of target species measurement.

While the invention described herein with reference to certain preferred embodiments, these embodiments have been presented by way of example only, and not to limit the scope of the invention. Additional embodiments thereof will be obvious to those skilled in the art having the benefit of this detailed description. Further modifications are also possible in alternative embodiments without departing from the inventive concept.

What is claimed is:

1. A process for quantifying a concentration of a targeted molecule M in a liquid sampling matrix, comprising the steps of:

detecting, by a detector, a pulsed source signal, a pulsed interference signal, and a pulsed reference signal after they penetrate into a spot of the liquid sampling matrix; obtaining, using signal processing, i) a first average ratio value for a first preselected period of time from the pulsed source signal and the pulsed reference signal emerging from the spot and ii) a second average ratio value for a second preselected period of time from the pulsed interference signal and pulsed reference signal; and

calculating, using electronics, a concentration of the targeted molecule M in the liquid sampling matrix based on the first average ratio value for the first preselected period of time and a calibration curve validated using the second average ratio value for the second preselected period of time,

wherein a signal source emits radiation at a signal wavelength which is within a first absorption band of the targeted molecule M, an interference source emits radiation at an interference wavelength which is within a second absorption band of at least one interfering molecule M_j , and a reference beam emits radiation at a reference wavelength which is neutral and is not within either the first absorption band or the second absorption band.

2. The process of claim 1, further comprising providing, by the electronics, the concentration of the targeted molecule M in the liquid sampling matrix as an output.

3. The process of claim 1, further including a pulsed beam comprised of an alternate and sequential pulsing of a repeating pattern of the pulsed signal source signal, followed by the pulsed reference signal, followed by the pulsed interference signal, followed by the pulsed reference signal.

4. The process of claim 1, further including a pulsed beam comprised of an alternate and sequential pulsing of a repeating pattern of the pulsed source signal, the pulsed reference signal and the pulsed interference signal.

5. The process of claim 1, wherein the pulsed source signal, the pulsed interference signal and the pulsed reference signal are each pulsed at a preselected frequency of at least N Hz which is sufficiently fast so that a given molecule of the targeted molecule M or the at least one interfering molecule M_j , will not pass in and out of the liquid sampling matrix within the preselected frequency.

6. The process of claim 5, wherein the frequency of N Hz is greater than 1.0 KHz with a duty factor of at least 10%.

7. The process of claim 1, wherein the at least one interfering molecule M_j absorbs radiation at the signal wavelength.

8. The process of claim 1, further comprising a pulsed beam having a signal beam center wavelength of 1,150 nm (1.150 μ m) and the pulsed reference signal has a center wavelength of 1,064 nm (1.064 μ m).

9. The process of claim 8, wherein the pulsed interference signal has a center wavelength of 1,210 nm.

10. The process of claim 9, wherein the targeted molecule M is glucose.

11. The process of claim 10, wherein the at least one interfering molecule M_j is comprised of a plurality of interfering molecules contained in a body interstitial fluid.

12. The process of claim 1, wherein radiation emerging from the spot is collected by a lens onto the detector.

13. An apparatus for quantifying a concentration of a targeted molecule M within a given time period in a liquid sampling matrix in which at least one interfering molecule M_j coexists with the targeted molecule, comprising:

at least one emitter for directing to a single spot of the liquid sampling matrix i) a signal source having radiation at a signal wavelength which is within a first absorption band of the targeted molecule M, ii) an interference source having radiation at an interference wavelength which is within a second absorption band of the at least one interfering molecule M_j , and iii) a reference source having radiation at a reference wavelength which is neutral and is not within either the first absorption band or the second absorption band;

a detector configured to detect infrared radiation from a pulsed source signal, a pulsed interference signal, and a pulsed reference signal from a pulsed beam after penetration into the spot; and

signal processing for obtaining (i) a first average ratio value for a preselected period of time from the pulsed source signal and the pulsed reference signal, and (ii) a second average ratio value for a second preselected period of time from the pulsed interference and the pulsed reference signal, from which a concentration of the targeted molecule M in the liquid sampling matrix can be calculated.

14. The apparatus of claim 13, wherein the pulsed beam comprises:

a signal source emitting radiation at the signal wavelength;

an interference source emitting radiation at the interference wavelength; and
a reference source emitting radiation at the reference wavelength.

15. The apparatus of claim 13, further comprising a multiplexer and a collimator configured to pulse infrared radiation from the signal source, the interference source and the reference source into the pulsed beam which is directed at the spot of the liquid sampling matrix.

16. The apparatus of claim 13, wherein the pulsed beam is comprised of an alternate and sequential pulsing of a repeating pattern of the signal source, followed by the reference source, followed by the interference source, followed by the reference source.

17. The apparatus of claim 13, wherein the pulsed beam is comprised of an alternate and sequential pulsing of a repeating pattern of the signal source, the reference source and the interference source.

18. The apparatus of claim 13, wherein the signal source, the interference source and the reference source are each pulsed at a preselected frequency of at least N Hz which is sufficiently fast so that a given molecule of the targeted molecule M or the at least one interfering molecule M_j will not pass in and out of the liquid sampling matrix within the preselected frequency.

19. The apparatus of claim 18, wherein the frequency of N Hz is greater than 1.0 KHz with a duty factor of at least 10%.

20. The apparatus of claim 13, wherein the at least one interfering molecule M_j absorbs radiation at the signal wavelength.

21. The apparatus of claim 13, wherein the pulsed source signal has a signal beam center wavelength of 1,150 nm (1.150 μ m) and the pulsed reference signal has a center wavelength of 1,064 nm (1.064 μ m).

22. The apparatus of claim 21, wherein the pulsed interference signal has a center wavelength of 1,210 nm.

23. The apparatus of claim 22, wherein the targeted molecule M is glucose, the at least one interfering molecule M_j is comprised of a plurality of interfering molecules contained in a body interstitial fluid and radiation emerging from the spot is collected by a lens onto the detector.

24. A process for quantifying a concentration of a targeted molecule M in a sample, comprising the steps of:
directing a signal source radiation at a signal wavelength within an absorption band of the targeted molecule M at a spot of the sample and a reference source radiation at a reference wavelength which is neutral and is not within the absorption band of the targeted molecule M at the spot of the sample;

processing the signal source radiation and the reference source radiation exiting the sample to obtain a value over a preselected period of time; and
calculating a concentration of the targeted molecule M in the sample based on the value.

25. The apparatus of claim 24, further comprising directing an interference source radiation at an interference wavelength which is within a second absorption band of the at least one interfering molecule M_j .

26. An apparatus for quantifying a concentration of a targeted molecule M in a sample in which at least one interfering molecule M_j coexists with the targeted molecule, comprising:

a device configured to direct, to a single spot of the sample, a signal source emitting radiation at a signal wavelength which is within a first absorption band of the targeted molecule M and a reference source emitting radiation at a reference wavelength which is neutral and is not within either the first absorption band or the second absorption band of the at least one interfering molecule M_j ; and

a detector configured to detect both the signal source radiation and the reference source radiation exiting the sample;

signal processing configured to:

process the signal source radiation and the reference source radiation exiting the sample to obtain a value over a preselected period of time; and

calculate a concentration of the targeted molecule M in the sample based on the value.

27. The apparatus of claim 26, further comprising an interference source emitting radiation at an interference wavelength which is within the second absorption band of the at least one interfering molecule M_j .

28. A process for calibrating an apparatus for quantifying a concentration of a particular molecule in a liquid in which the concentration of the particular molecule varies over time, comprising the steps of:

selecting a sample of the liquid;

selecting a measurement time period for calibration;

determining a concentration level of the particular molecule in the sample for the measurement time period; and

calibrating the concentration level of the particular molecule versus a measured total transmittance contributed by interfering molecules of the sample to compensate for Absorption Interference Noise (AIN) arising from the interfering molecules in the sample.

* * * * *