

INVENTORS
Raymond W. Barton
Joe Thomas Hemmick
BY Hoffman, Wagner, Kelley, Stillman & DeCord
ATTORNEYS

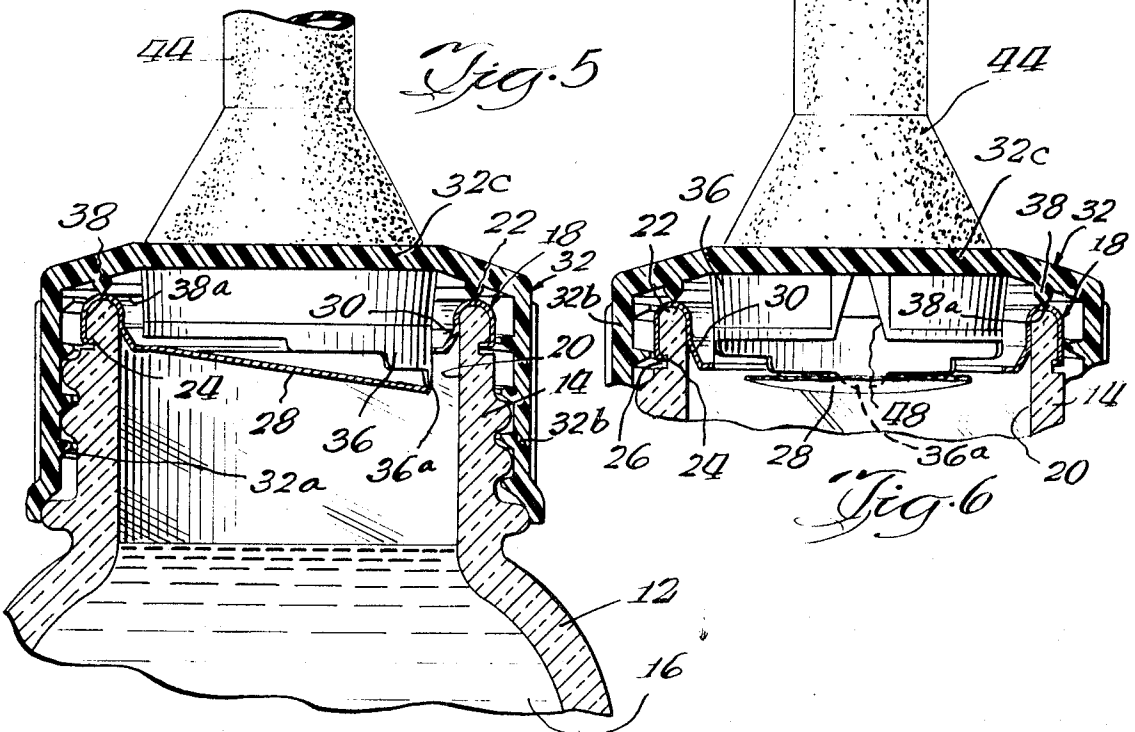

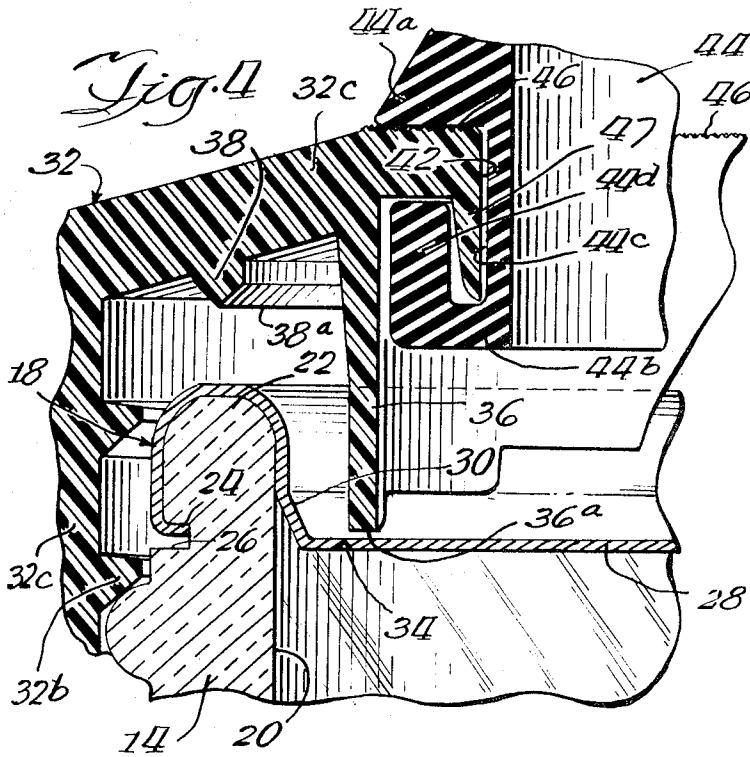
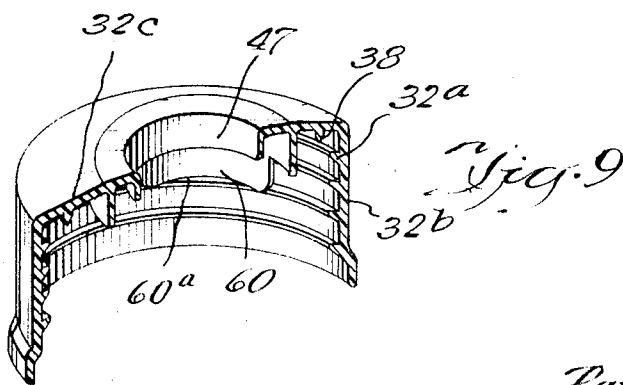
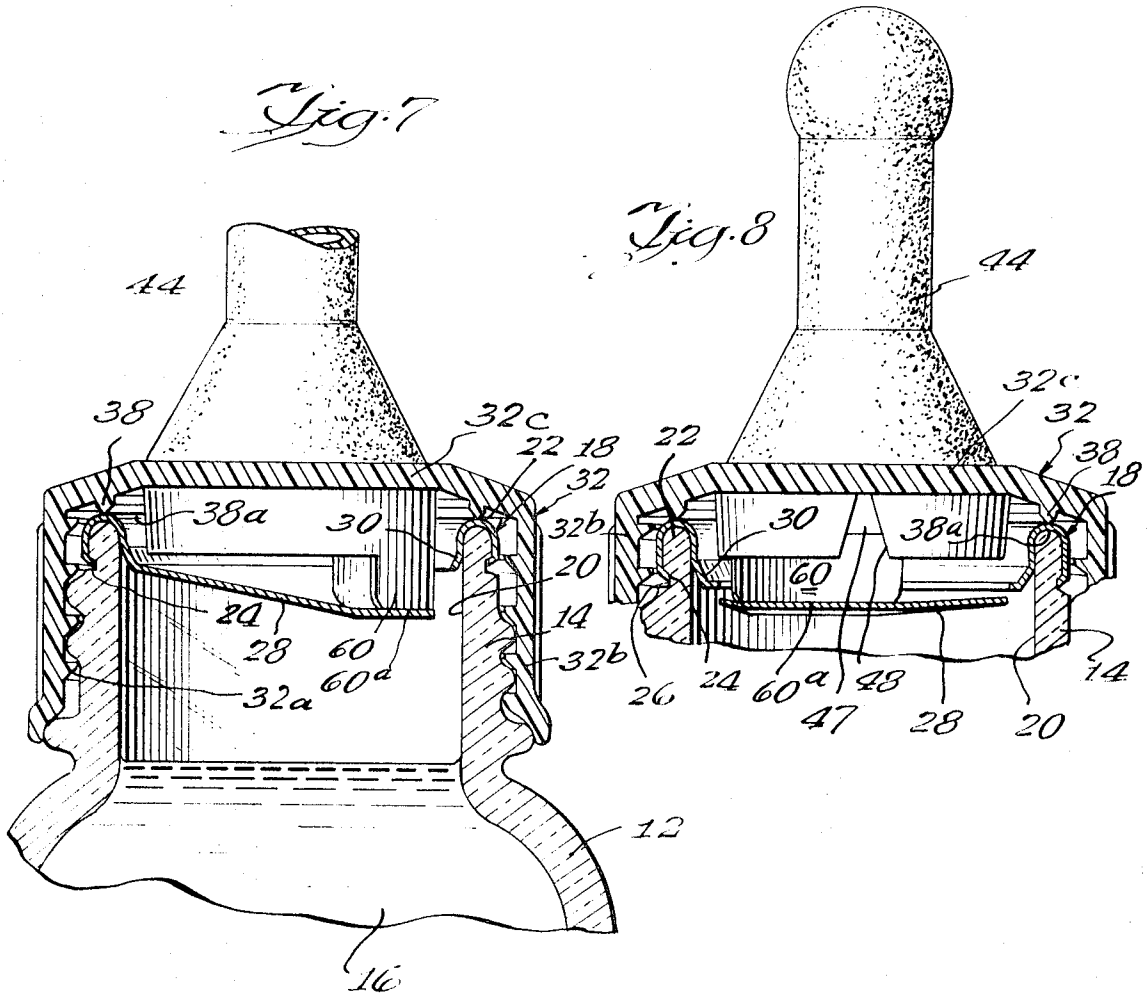

INVENTORS
Raymond W. Barlow
Joe Thomas Hemmick
Trey Loggins, Hequer, Allen, Stillman & Holard
ATTORNEYS

NURSER

SUMMARY OF THE INVENTION

This is a continuation-in-part application of our copending application, Ser. No. 809,183, filed Mar. 21, 1969, now abandoned and entitled "Nursur."

This invention relates to container means and more particularly to a nursing container assembly for infant feeding. The container and contents are presterilized and the container is designed to be discarded after use.

It is accordingly an object of the present invention to provide a food dispensing package in ready-to-use form for infant feeding to significantly eliminate home preparation.

Another object of the invention is to provide an infant feeding container which is easy and convenient to use and the parts thereof are so arranged for presterilization, and the container is rendered ready for use without contamination.

The above objects and other advantages of the invention are permitted by the provision of a nursing container assembly which includes a container member having an upstanding threaded neck portion, a relatively thin wall closing the upper end of the neck portion, score means on the underside of a portion of the wall for facilitating separation of the wall along the threaded neck portion, a nipple seated on the screwcap, and a projection on the underside of the screwcap for applying concentrated pressure adjacent the score means in response to rotation of the screwcap as the cap is turned onto full threaded engagement with the neck portion so that the wall will be separated along the score means and liquid within the container member can be extracted through the nipple. Preferably, the score means is formed in a circular pattern concentric with the axis of rotation of the screwcap and the projection on the underside of the screwcap is spaced from the axis of rotation and terminates in a blunt lower edge for engaging the wall adjacent to and internally concentric with, but not overlying, the score means to cause separation of the wall by breaking action along the score means and thereby avoid the forming of residue and therefore avoid depositing residue from the wall into the liquid in the container member.

The separable wall comprises a portion of a relatively thin crimp cap crimped over the outermost end of the threaded neck portion with the wall extending transversely across substantially the entire inside of the neck portion generally in a plane spaced from the outermost end of the neck so as to be recessed within the neck. An annular ridge depends from the underside of the screw cap and terminates in a sharp annular edge which abuts against the portion of the crimp cap which overlies the top marginal rim of the neck portion to provide a seal between the crimp cap and the screwcap as the screwcap is turned onto full threaded engagement with the neck portion.

An opening is formed centrally through the screwcap about which the nipple is seated. A marginal generally planar surface surrounds the opening and the nursing nipple has a bottom laterally extending peripheral flange portion dimensioned for overlying the marginal planar surface. A relatively fine scoring means, such as by sandblasting, is formed on the planar surface to provide a vent means between the nipple and the screwcap.

Other objects, features and advantages of the invention will become apparent from the following detailed description taken in connection with the accompanying drawings.

DESCRIPTION OF THE DRAWINGS

FIG. 1 is an elevational view of a nursing container assembly constructed in accordance with the principles of this invention;

FIG. 2 is a partial vertical section taken generally along the line 2-2 of FIG. 1;

FIG. 3 is a sectional view taken generally along the line 3-3 of FIG. 2, with a portion of the base of the nipple cut away to facilitate the illustration;

FIG. 4 is a fragmentary section, on an enlarged scale, of a portion of the nursing container assembly shown in FIG. 2;

FIG. 5 is a view similar to that of FIG. 2, but showing the assembly with the outer cover removed and the inner cap tightened onto the container neck;

FIG. 6 is a view similar to that of FIG. 5, but rotated 90°, as to be looking to the right in FIG. 5;

FIG. 7 is a view similar to that of FIG. 5, but showing a modified form of the invention;

FIG. 8 is a view similar to that of FIG. 6, but showing the form of the invention FIG. 7; and

FIG. 9 is a perspective view, partially broken away and on a reduced scale, of the screwcap shown in FIGS. 7 and 8.

DETAILED DESCRIPTION OF THE INVENTION

Referring now to the drawings, a nursing container assembly embodying the novel concepts of this invention is designated therein in its entirety generally by the numeral 10, and includes a bottlelike container member 12 which has a relatively rigid, upstanding threaded neck portion 14. As will be set forth in greater detail hereinafter, the nursing container assembly of this invention is designed in ready-to-use form, the container member 12 is prefilled with an infant formula 16 and the assembly is presterilized.

A seal means in the form of a crimp cap, generally designated 18 and preferably of thin metallic material, hermetically seals the container member 12 at the open mouth 20 of the threaded neck portion 14. The cap overlies the top marginal rim 22 of the neck portion 14, is crimp-sealed thereon and has an inwardly turned lip 24 crimped within an undercut groove 26 on the outside of the neck portion 14. The crimp cap includes a relatively thin wall 28 which extends transversely across substantially the entire inside of the neck portion, closing the open mouth 20, and lying generally in a plane which is spaced from the top marginal rim 22 of the neck portion 14. The infant formula 16 is processed while in the container member 12 and with the cap 18 crimped over the upstanding neck portion 14, with the wall 28 spanning a substantial portion of the open mouth 20 of the container member. During processing, the formula, the container member and the assembled crimp cap are subjected to rapidly fluctuating and widely ranging temperatures resulting in a wide and fluctuating range of pressures within the container member. Such fluctuations tend to cause the relatively thin wall 28 to flex back and forth during processing. It has been found that by "recessing" or spacing the wall 28 inwardly from the outermost end of the neck portion 14, this flexing is reduced to a minimum and thereby reducing the chances of accidental rupturing of the wall 28 at the scored area. The wall 28 is reinforced in its recessed position by an annular wall portion 30 of the crimp cap 18, the annular wall 30 extending around the inside of the neck portion 14 adjacent the top marginal edge thereof.

Threadably associated with the neck portion 14 of the container member 12 is an inner, internally threaded screwcap, generally designated 32, equipped at 32a with complementary threads on the inner diameter of an annular skirt 32b integral with a transverse wall or roof portion 32c. The screwcap 32 is of sufficient thickness to provide the requisite rigidity, and preferably is of plastic or like material.

Score means 34, as best illustrated in FIG. 4, is provided on the underside of the thin wall 28 of the crimp cap 18. The score means comprises a V-shaped cut on the underside of the wall and extending in a circular pattern concentric with the axis of rotation of the screwcap 32, essentially the radial center of the wall or roof portion 32c. The score means 34 facilitates separation of the wall 28 along the score means when the wall is subjected to a concentrated pressure internally adjacent the score means. The scoring 34 is something

less than a 360° circle to prevent wall separation over an entire circle and prevent the separated portion of the wall from falling into the formula. Formed integral with the screwcap 32 and spaced from the radial center of the wall portion 32c is means for applying concentrated pressure adjacent the score means 34 in response to rotation of the screwcap 32 as the cap is turned onto full threaded engagement with the neck portion 14 so that the wall 28 will be separated along the score means and the infant formula 16 within the container member 12 can pass through the wall 28. The pressure applying means shown herein comprises an annular projection 36 which depends from the underside of the roof portion 32c of the screwcap 32. The annular projection 36 is formed integral with the cap 32 and terminates in a relatively blunt lower edge portion 36a spaced from the axis of rotation of the screwcap and disposed internally adjacent to, but not overlying, the score means 34 to separate the wall 28 along the score means. The lower edge of the annular portion 36 on opposite sides of the lower edge portion 36a is stepped upwardly away from the lower edge portion to provide support and to provide relief on both sides of the lower edge portion so that only the edge 36a engages the wall 28. The pressure applying annular projection 36 is shown herein as disposed on the inside of the circular score means 34. With the score means formed on the underside of the wall 28 and with the projection 36 applying pressure adjacent to but not over the score means, separation of the wall 28 is effected by a breaking action, rather than a cutting action, along the score means and such action prevents the formation of residue from the wall 28 and consequently eliminates the deposit of any residue in the infant formula.

Formed integral with the capscrew 32 is an annular ridge 38 which depends from the underside of the roof portion 32c of the screwcap and terminates in a sharp annular edge 38a which, as the screwcap 32 is turned onto full threaded engagement with the neck portion 14, abuts against the portion of the crimp cap 18 which overlies the top marginal rim 22 of the neck portion 14 to provide a seal between the screwcap 32 and the crimp cap 18.

Referring to FIGS. 2 through 4, the transverse wall or roof portion 32c of the screwcap 32 has a central circular opening 42 about which is seated a nursing nipple 44. On the top surface of the transverse wall 32c and about the opening 42 is a circular, marginal planar portion 46 which has score means preferably disposed on substantially the entire area of the planar portion 46. In the form of the invention, the score means is formed by sandblasting so as to have a relatively fine scored surface. The nursing nipple 44 has a bottom laterally extending peripheral flange portion 44a dimensioned for overlying the marginal planar portion 46 and preferably within the bounds of the scoring whereby the scoring provides a vent means between the nipple flange 44a and the top surfaces of the transverse wall 32c of the screwcap.

Referring to FIGS. 3, 4 and 6, the nursing nipple 44 has a downwardly depending, U-shaped flange 44b which forms a vertically extending, upwardly opening groove 44c for receiving a downwardly depending annular flange 47 formed integral with the transverse wall portion 32c of the screwcap. The flange 47 thus is disposed in an overlapping relationship with an outer lip portion 44d of the nipple to facilitate holding the nipple in its seated position on the top wall portion 32c of the screwcap and about the opening 42. Referring to FIG. 6, the annular projection 36 has a generally V-shaped notch 48 formed therein at the short dimension of the projection, diametrically opposite the lower, blunt surface 36a which engages the rupturable wall 28. It has been found that this V-shaped notch 48 facilitates the venting of air from the atmosphere to the interior of the container member 12, past the nipple 44, when in use.

An outer cover member, generally designated 50, is provided for the nursing container assembly and is generally of cuplike form comprising a horn-shaped top portion 50a consisting of a generally frustoconical side wall 50b (FIG. 2) closed at its upper end by a top wall 50c (FIG. 1), and a

generally cylindrical skirt 50d depending from and formed integrally with the lower edge of the sidewall 50b. The cylindrical skirt 50d is undulated to mate with an outer undulated surface on the screwcap skirt 32b to provide a better grip on the exterior of the screwcap 32. The bottom of the outer cover member 50 is sealed with the lower portion of the threaded neck 14 and the upper extreme portion of the container member 12 by a bandlike closure member 52, shown to be transparent in FIG. 1. The band 52 is a heat shrinkable vinyl band which is heat shrunk to a position shown in FIG. 2 to provide a hermetic seal between the container member 12 and the outer cover member 50. Referring to FIG. 1, the heat shrink band 52 is provided with a pair of vertical scoring slits 52a which are generally parallel and flared at their upper end as at 52b to provide an easily accessible lip 52c which can be utilized to tear the heat shrink band 52 in the direction of arrow A (FIG. 1). The band 52 not only provides a seal from the atmosphere, but it provides a tamperproof seal to give visual evidence that the cap or cover has not been removed. The undulated skirt 50d of the outer cover member 50 is utilized to transfer hand pressure to the screwcap skirt 32b in order to turn the screwcap onto full threaded engagement with the neck portion 14 of the container member 12 so that the wall 28 will be separated and liquid within the container member can be extracted through the wall. In this manner, the nipple 44 is not touched when the screwcap is turned to separate the wall 28.

The container assembly 10, as shown in FIGS. 1 and 2, as was noted hereinabove, is filled to the desired level by admitting the infant formula 16 or other liquid food through the open mouth 20 in the neck portion 14 of the container member 12. The crimp cap 18 is then sealed in the position shown, the formula is processed and the filled container is sterilized. The assembly of the cap 32, nipple 44 and cover 50 are sterilized in a separate operation and the assembly is placed on the container 10 under aseptic conditions, with the screwcap 32 threaded upon the neck portion to the extent illustrated in FIG. 2, whereby the blunt, pressure applying edge 36a of the downwardly depending projection 36 is spaced slightly from the separable wall 28. The sealing strip 52 is then positioned about the skirt portion 50d of the outer cover member and the upper portion of the container member 12, at the juncture of the neck portion 14, and heat shrunk as shown. The nursing container assembly as thus assembled is suitably sterilized and housed in any desirable outer package.

To utilize the container assembly 10 after removal from the outer package, the heat shrink band 52 is torn along the scoring lines 52a. Then, by grasping the skirt portion 50d of the outer cover member 50 and turning the same in a tightening direction, the screwcap 32 correspondingly is tightened and the pressure applying edge 36a comes in contact with the upper surface of the separable wall 28 and further tightening causes the wall to separate by breaking, without cutting, along the circular score line 34. As noted above, during this tightening action, there is no necessity for the nipple to be exposed and thereby touched by the hands or other contaminating influence, as so often characterizes known nursing containers. It is to be further observed that, as above noted, no harmful residue from the separable wall 28, as would likely result from a cutting action, is deposited within the formula 16.

FIGS. 7 through 9 show a modified form of the invention. In these figures like numerals have been applied to like elements as described in relation to FIGS. 1 through 6. In FIGS. 1—6, the annular projection 36 for applying pressure to separate the wall 28 along the score means has a stepped shape which terminates in a relatively small radius lower edge portion 36a. In the form of the invention shown in FIGS. 7—9, a modified projection 60 is provided. This projection 60 is annularly shaped, but has a wider, flatter lower edge portion 60a which provides a greater pressure applying edge for separating the wall 28 along the score means. The projection 60 is rounded at its corners on approximately a one-fourth inch radius to facilitate camming the separated wall downwardly as shown in FIGS. 7 and 8.

The foregoing detailed description has been given for clearness of understanding only and no unnecessary limitations should be understood therefrom as some modifications will be obvious to those skilled in the art.

We claim:

1. In combination, a nursing container having an opening with a generally planar portion substantially entirely about said opening, a nursing nipple seated on the container about said opening and having an upstanding portion and a bottom laterally extending flange portion dimensioned for overlying said generally planar portion, and means defining a fine eroded planar surface on substantially the entire area of said planar portion to provide vent means between the nipple and the container adjacent said opening.

2. The combination of claim 1 wherein said generally planar portion of said container is formed of relatively rigid plastic material on which said means is formed as by sandblasting.

3. The combination of claim 1 wherein said nursing container includes a container member, and a cap member of relatively rigid plastic material, said opening being formed in said cap member, said means defining said planar portion being formed on said cap member about said opening, and said nursing nipple being seated on said cap member.

4. In combination, a nursing container, a nursing nipple, means defining complementarily engaging surfaces of substantial area on said container and said nipple, the surface on the container being formed of generally rigid material, and means defining a fine eroded surface portion on substantially the entire area of the engaging surface of said container for providing vent means between the container and the nipple.

5. A nursing container assembly, comprising a container member having an upstanding threaded neck portion terminating in an open mouth, a screwcap received on said neck portion, a nipple seated on said screwcap, and means defining an annular ridge depending from the underside of the screwcap and terminating in a sharp annular edge which abuts against the top marginal rim of said neck portion as the screwcap is turned onto full threaded engagement with said neck portion to provide a seal between said container member and said screwcap.

6. The nursing container of claim 5 wherein at least said annular ridge on said screwcap is formed of plastic material providing sufficient resiliency for said sharp edge to facilitate sealing.

7. A nursing container assembly comprising, a container member having an upstanding threaded neck portion, a relatively thin, generally rigid wall closing the upper end of said neck portion, a screwcap received on said threaded neck portion and having a transverse wall portion overlying said thin wall when received on said threaded neck portion, a nipple seated on said transverse wall portion of said screwcap about an opening in said wall portion, score means formed on said thin wall in a circular pattern concentric with the axis of rota-

tion of said screwcap, and projection means depending from the underside of the transverse wall portion of said screwcap, spaced from said axis adjacent to but not overlying said circular score means for applying concentrated pressure adjacent to and progressively along the score means in response to rotation of said screwcap as the cap is turned onto full threaded engagement with said neck portion so that said generally rigid thin wall will be separated by a breaking action along the score means and liquid within the container member can be extracted through the nipple.

8. The nursing container assembly of claim 7 wherein said thin wall is fabricated of metallic material, said score means is formed on the underside of the thin wall, and said projection means has a blunt lower edge for engaging said thin wall adjacent the circular score means to cause said separation of the wall by a breaking action along the score means and thereby avoid the forming of residue which might be deposited into the liquid in the container member.

9. The nursing container assembly of claim 8 wherein the lower blunt edge of said projection mean is disposed so as to engage said generally rigid thin wall on the inside of said circular score means.

10. A nursing container assembly comprising a container member having an upstanding threaded neck portion, a relatively thin wall closing the upper end of said neck portion, said wall comprising a portion of a relatively thin crimp cap for over the outermost end of said neck portion, said wall extending transversely across substantially the entire inside of said neck portion generally in a plane spaced from the outermost end of the neck portion so as to be recessed within said neck portion, score means on a portion of the wall for facilitating separation of the wall along the score means when the wall is subjected to a concentrated pressure adjacent the score means, a screwcap received on said threaded neck portion, a nipple seated on said screwcap, and means for applying concentrated pressure adjacent said score means in response to rotation of said screwcap as the cap is turned onto full threaded engagement with said neck portion so that the wall will be separated and liquid within the container member can be extracted through the nipple.

11. In a nursing container assembly which includes a container member having an upstanding neck portion, a relatively thin wall closing the upper end of the neck portion, a cap received on said neck portion, and a nipple seated on said cap, said thin wall being frangible to permit liquid within the container member to pass therethrough for extraction through the nipple, the improvement wherein said thin wall comprises a portion of a relatively thin crimp cap crimped over the outer end of said neck portion, said wall extending transversely across substantially the entire inside of said neck portion generally in a plane spaced inwardly from the outer end of the neck portion so as to be recessed within said neck portion.

55

60

65

70

75

UNITED STATES PATENT OFFICE
CERTIFICATE OF CORRECTION

Patent No. 3,586,196 Dated June 22, 1971

Inventor(s) Raymond W. Barton and Joe Thomas Herron

It is certified that error appears in the above-identified patent and that said Letters Patent are hereby corrected as shown below:

Claim 10, line 26, change "for" to -- crimped --.

Signed and sealed this 4th day of January 1972.

(SEAL)

Attest:

EDWARD M. FLETCHER, JR.
Attesting Officer

ROBERT GOTTSCHALK
Acting Commissioner of Patents