

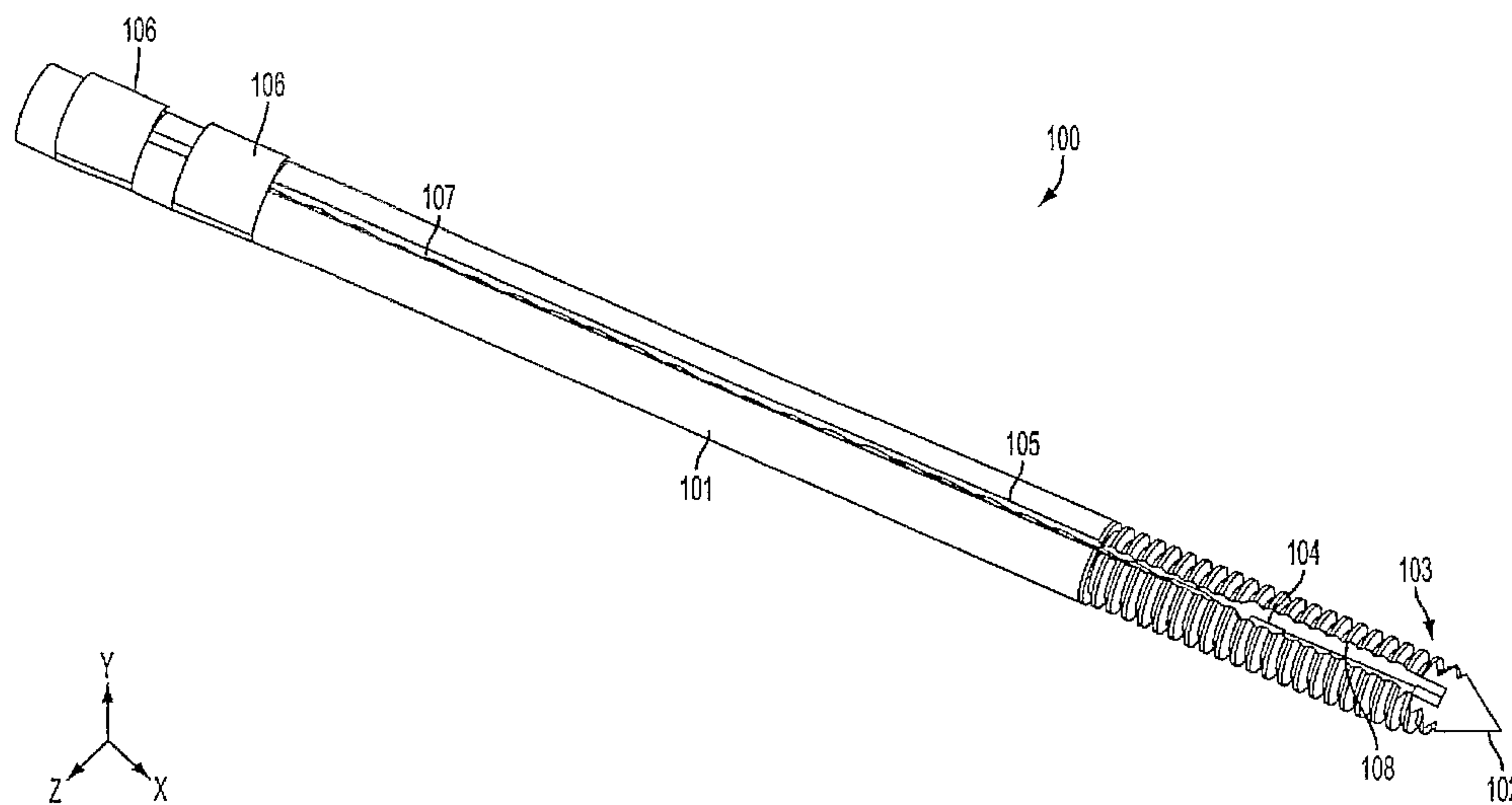

(86) Date de dépôt PCT/PCT Filing Date: 2006/01/18  
 (87) Date publication PCT/PCT Publication Date: 2006/07/27  
 (85) Entrée phase nationale/National Entry: 2007/05/17  
 (86) N° demande PCT/PCT Application No.: US 2006/001662  
 (87) N° publication PCT/PCT Publication No.: 2006/078677  
 (30) Priorité/Priority: 2005/01/18 (US60/644,007)

(51) Cl.Int./Int.Cl. *A61B 5/05* (2006.01)  
 (71) Demandeur/Applicant:  
TRAXTAL INC., CA  
 (72) Inventeur/Inventor:  
GLOSSOP, NEIL DAVID, CA  
 (74) Agent: SMART & BIGGAR

(54) Titre : DISPOSITIF A FIL K GUIDE ELECTROMAGNETIQUEMENT  
 (54) Title: ELECTROMAGNETICALLY TRACKED K-WIRE DEVICE



(57) **Abrégé/Abstract:**

Devices and methods for registering, dynamically referencing, and navigating an anatomical region of interest of a patient are provided using a tracked Kirschner wire (K-wire), where the K-wire includes a position-indicating element.

(12) INTERNATIONAL APPLICATION PUBLISHED UNDER THE PATENT COOPERATION TREATY (PCT)

(19) World Intellectual Property Organization  
International Bureau(43) International Publication Date  
27 July 2006 (27.07.2006)

PCT

(10) International Publication Number  
**WO 2006/078677 A2**(51) International Patent Classification:  
A61B 5/05 (2006.01)(21) International Application Number:  
PCT/US2006/001662

(22) International Filing Date: 18 January 2006 (18.01.2006)

(25) Filing Language: English

(26) Publication Language: English

(30) Priority Data:  
60/644,007 18 January 2005 (18.01.2005) US(71) Applicant (for all designated States except US): **TRAX-TAL TECHNOLOGIES INC.** [CA/CA]; 49 Spadina Avenue, Suite 402C, Toronto, Ontario M5V 2J1 (CA).

(72) Inventor; and

(75) Inventor/Applicant (for US only): **GLOSSOP, Neil, David** [US/CA]; 49 Spadina Avenue, Suite 402C, Toronto, Ontario M5V 2J1 (CA).(74) Agents: **ROONEY, Timothy, C.** et al.; Pillsbury Winthrop Shaw Pittman LLP, P.O. Box 10500, McLean, VA 22102 (US).

(81) Designated States (unless otherwise indicated, for every kind of national protection available): AE, AG, AL, AM, AT, AU, AZ, BA, BB, BG, BR, BW, BY, BZ, CA, CH, CN, CO, CR, CU, CZ, DE, DK, DM, DZ, EC, EE, EG, ES, FI, GB, GD, GE, GH, GM, HR, HU, ID, IL, IN, IS, JP, KE, KG, KM, KN, KP, KR, KZ, LC, LK, LR, LS, LT, LU, LV, LY, MA, MD, MG, MK, MN, MW, MX, MZ, NA, NG, NI, NO, NZ, OM, PG, PH, PL, PT, RO, RU, SC, SD, SE, SG, SK, SL, SM, SY, TJ, TM, TN, TR, TT, TZ, UA, UG, US, UZ, VC, VN, YU, ZA, ZM, ZW.

(84) Designated States (unless otherwise indicated, for every kind of regional protection available): ARIPO (BW, GH, GM, KE, LS, MW, MZ, NA, SD, SL, SZ, TZ, UG, ZM, ZW), Eurasian (AM, AZ, BY, KG, KZ, MD, RU, TJ, TM), European (AT, BE, BG, CH, CY, CZ, DE, DK, EE, ES, FI, FR, GB, GR, HU, IE, IS, IT, LT, LU, LV, MC, NL, PL, PT, RO, SE, SI, SK, TR), OAPI (BF, BJ, CF, CG, CI, CM, GA, GN, GQ, GW, ML, MR, NE, SN, TD, TG).

Published:

— without international search report and to be republished upon receipt of that report

For two-letter codes and other abbreviations, refer to the "Guidance Notes on Codes and Abbreviations" appearing at the beginning of each regular issue of the PCT Gazette.

(54) Title: ELECTROMAGNETICALLY TRACKED K-WIRE DEVICE

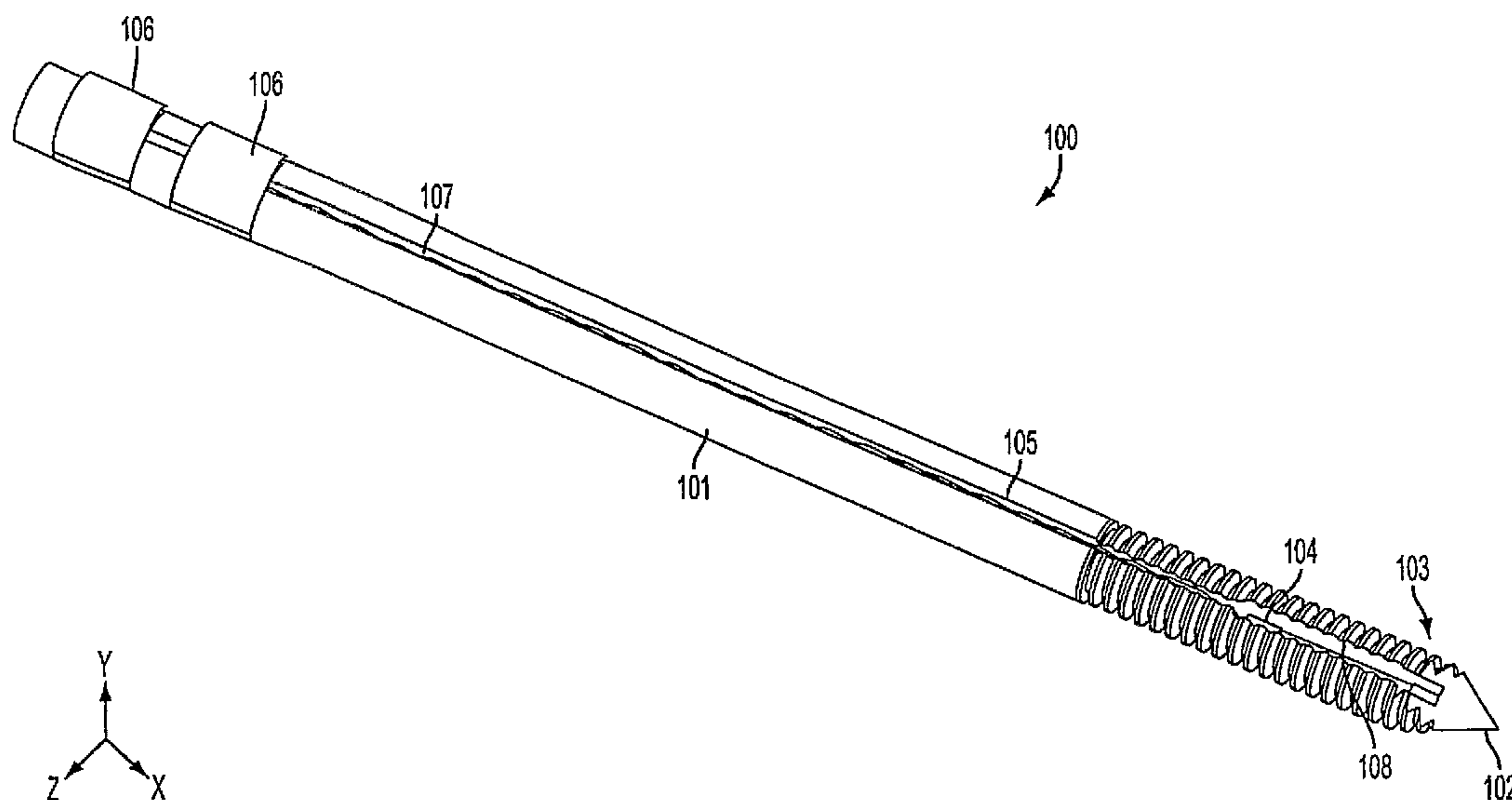

(57) Abstract: Devices and methods for registering, dynamically referencing, and navigating an anatomical region of interest of a patient are provided using a tracked Kirschner wire (K-wire), where the K-wire includes a position-indicating element.



WO 2006/078677 A2

## Electromagnetically Tracked K-wire Device

### Related Applications

**[001]** This application claims priority to U.S. Provisional Patent Application Serial No. 60/644,007, filed January 18, 2005, which is hereby incorporated by reference herein in its entirety.

### Field of the Invention

**[002]** The invention relates to electromagnetically tracked K-wire devices.

### Background of the Invention

**[003]** Image-guided surgery systems use a position sensor system to graphically overlay an iconic representation of a tracked surgical instrument onto pre-acquired images (e.g., CT, MR, fluoroscopic X-ray or other images) of the patient. Current state of the art tracking employs optical systems characterized by a high degree of accuracy. However, the ergonomics of these systems are poor, and optical systems require that tracked objects remain in the camera's line of sight, relatively distant from the instrument tip. The relatively heavy and large position-indicating elements must be attached to rigid instruments to achieve the required accuracy. In particular, maintaining a line of sight path can be cumbersome for the physician and complicate the already delicate operating environment. Together, these drawbacks may lower the acceptance of computer-assisted surgery among physicians.



**[004]** A new generation of electromagnetic trackers, with increased accuracy and the ability to track objects in ferromagnetic environments, is becoming available. Electromagnetic tracking systems do not require that a direct line of sight be maintained. In addition, these new generation electromagnetic trackers ("position sensors") use position-indicating elements that are extremely small. The systems normally consist of a control unit, sensor interface device, and field generator. The position-indicating elements consist of small coils that connect to the sensor interface unit.

**[005]** Image guidance workstations for use in spine surgery have been commercially available for over a decade. These existing CAS workstations are based on optical tracking systems, which do not allow accurate tracking of flexible instrumentation. Flexible instrumentation is generally smaller and less invasive than rigid instrumentation. Current minimally invasive CAS techniques have been limited to rigid instruments due to the tracking technology.

**[006]** K-wires in general are known. In present clinical practice, K-wires are an essential part of many orthopaedic procedures including spinal fusion, fracture fixation and stabilization. K-wires can also serve as a guides or "trials" for screw placement during instrumented fixation. In some surgical procedures, the K-wires are used to stabilize or manipulate the bones. In others, cannulated screws may be inserted over the K-wire and placed through the bone either to serve as anchor points for plates or stabilizing hardware, or to unite a fracture. The K-wire may be removed or left in place at the end of the procedure. Other uses are possible.

**[007]** Any misplacement of the K-wire can result in misplacement of the screw or misalignment of a fracture, with potentially catastrophic consequences for the patient. For example, if the K-wire is placed through a critical structure such as a nerve or blood vessel during a spine operation, paralysis or death could result. Misplaced wires can result in decrease in integrity of the fusion or reduced strength of any construct. K-wires are often inserted percutaneously into the bone making it difficult to know where the wire is going without constant x-rays.

**[008]** One of the drawbacks of conventional image-guided surgery is that the instrument that is actually tracked is usually the holder or driver of the inserted tool. For example, K-wires are often tracked by tracking the drill or a drill guide used to install them, which is proximal to the end actually inserted in the patient. While the tip of a stiff or rigid instrument may remain static with respect to the tracker, a thin proximally tracked K-wire might easily bend during drilling or placement, rendering a trajectory based on the proximally placed tracker prone to error. This deviation may be easily overlooked as it may occur unless constant imaging is used or the position of the wire is directly and continually viewed by the physician. This later option is essentially impractical in minimally invasive surgery however.

**[009]** Also, given the static nature of the backdrop projection images in image guided surgery, this error would not be detected during a conventional image guided surgical procedure until a fluoroscopic view is taken.

**[010]** Other problems and drawbacks exist with known systems and techniques.

**SUMMARY OF THE INVENTION**

**[011]** An object of the invention is to overcome at least some of these and/or other drawbacks of prior systems and techniques.

**[012]** One aspect of the invention relates to a method for directly tracking the tip of the K-wire (e.g., electromagnetically). Among other things this may provide a significant improvement and can lead to increased accuracy and decreased use of intra-operative X-rays. In contrast, optical tracking systems generally are not capable of effectively tracking the tip since they are typically limited to line of sight applications. This makes it difficult for them to track the distal end of the K-wire that is implanted in the patient. The electromagnetically tracked K-wires would offer a dramatic reduction in surgical invasiveness as compared with current CAS procedures. They would be compatible with existing CAS modalities including conventional (point match registration), virtual fluoroscopy and 2D-3D. In addition to aiding in cannulating the pedicle, a tracked K-wire could potentially assist in other aspects of the current technique including registration, dynamic referencing and verification of registration.

**[013]** According to one embodiment, the invention comprises a K-wire having a shaft section, a tip section and an optionally threaded portion along all or part of its length. The K-wire contains an electromagnetically tracked position-indicating element near its tip. Lead-wires of the position-indicating element may be connected to conductive connection bands. The connection



bands may be placed at the proximal end of the K-wire. To facilitate placement of the position-indicating element and wiring, a groove may be machined along the length of the K-wire. The position-indicating element can be embedded into a groove machined into the tip of the K-wire.

**[014]** The various objects, features, and advantages of the invention will be apparent through the detailed description of the preferred embodiments and the drawings attached hereto. It is also to be understood that the following detailed description is exemplary and not restrictive of the scope of the invention.

#### **Brief Description of the Drawings**

**[015]** Fig. 1 depicts a schematic illustration of the K-wire according to one embodiment of the invention.

**[016]** Fig. 2 depicts an exploded view of the K-wire according to one embodiment of the invention.

**[017]** Fig. 3 depicts a cross section showing the tracked K-wire according to one embodiment of the invention.

**[018]** Fig. 4A depicts a tracked K-wire and a slip coupling mechanism according to an embodiment of the invention.

**[019]** Fig. 4B depicts a tracked K-wire and a cross section of a slip coupling mechanism according to an embodiment of the invention.

**[020]** Fig. 5 depicts a tracked K-wire attached to a power drill, according to one embodiment of the invention.

**[021]** Fig. 6 depicts a non-rotary coupling used to achieve contact with the position-indicating elements embedded in the K-wire, according to one embodiment of the invention.

**[022]** Fig. 7A depicts a tracked K-wire according to an embodiment of the invention.

**[023]** Fig. 7B depicts the tip of a tracked K-wire according to an embodiment of the invention.

**[024]** Fig. 8 depicts a method using a tracked K-wire according to an embodiment of the invention.

**[025]** Fig. 9 depicts a method using a tracked K-wire according to an embodiment of the invention.

**[026]** Fig. 10 depicts a method using a tracked K-wire according to an embodiment of the invention.

### **Detailed Description**

**[027]** One embodiment of the invention is shown by way of example in Fig. 1. As shown, the device includes a K-wire 100 comprised of a shaft section 101, a tip section 102, and an optionally threaded portion 103, along all or part of its length. The K-wire contains at least one electromagnetically tracked position-indicating element 104 embedded near its tip. The lead-wires 105 of the position-indicating element are connected to connection bands 106, which may be coated with gold or other suitable conductive coating. The connection bands may be placed at the proximal end of the K-wire or otherwise.



**[028]** To facilitate placement of the position-indicating element and wiring, a groove 107 may be machined along all or part of the length of the K-wire. The tip 102 is preferentially made sharp, for example as a trocar 3 point tip. Likewise, the position-indicating element 104 can be embedded into a groove 107, machined into the tip of the K-wire.

**[029]** Fig. 2 depicts an exploded view of the K-wire according to one embodiment of the invention. Fig. 2 depicts various components. Numeral 201 denotes the electrical components of the device including the position-indicating element, the leadwires 202, and the connection bands 203. As shown, radio-opaque fiducials are included on or around the position-indicating element coil 204 to assist in radiologically locating the position-indicating element as an adjunct to registration, dynamic referencing or verification of system accuracy.

**[030]** These fiducials are described in detail in U.S. Patent No 6,785,571, to Glossop, which is hereby incorporated by reference herein in its entirety. However the invention is not so limited. These fiducials may or may not be present in the various configurations of the device and other techniques may be used. Various mechanical parts of the system are indicated as 205, which includes the shaft 206, the milled groove features 207, for burying the position-indicating element and wires beneath the main shaft body so they do not become damaged when the K-wire is drilled into bone. Features 208 are used to assist with assembly of the electrical contacts, 203 and may incorporate insulation layers (not shown). Other components may also be used.

**[031]** Fig 3 shows a cross section showing the tracked K-wire 300. The connection bands are shown at 301. The connection wires 302 are inside the groove and the position-indicating element 303 is embedded in the groove. Position-indicating element 303 may be placed along the longitudinal axis of rotation of the K-wire or otherwise.

**[032]** Figs. 4A and 4B depict additional items that may be used in a K-wire connection assembly 400 according to one embodiment of the invention. In order to maintain contact of the position-indicating element while drilling the K-wire into place, the connection bands can be connected to a slip ring or slip coupling. Slip rings and slip couplings generally are known. Element 401 represents the tracked K-wire and element 402 refers to a slip-coupling mechanism. Slip couplings are available commercially to a high degree of accuracy and reliability.

**[033]** The connection bands may be made from any conductive material. In one embodiment they can be fabricated from stainless steel. In some embodiments, the bands can be made from a material plated with a conductive material such as gold. Other connection bands can be used. Other types of connectors may also be used, including, for example, spot connectors, axial connectors, or other type of connection enabling electrical signals from the position-indicating element to be connected to an external device.

**[034]** Two examples of coupling mechanisms are shown. Others can be used. In the embodiment depicted in Figs 4A and 4B, a commercial coupling is specifically modified with an adaptor socket portion 403 capable of

accepting the shaft of the K-wire. The K-wire depicted here has a hexagonal or other non-rotational head 404 machined on it. The K-wire's contacts 405, non-rotationally couple to the adaptor socket 403. The adaptor socket may be fixed permanently to the rotational portion of the coupling 406 so that the signals from the position-indicating element are conducted through the fixed portion of the coupling 407 and out through the leads 408.

**[035]** The cross sectional view (Fig. 4B) shows additional details of the device, according to one embodiment of the invention. Contacts 409 may be fixed contacts inside the receptacle. These contacts mate with the K-wire and remain relatively stationary with respect to it. The wires 410 may be wires intrinsic to the slip coupling. These wires 410 may lead back through the slip coupling 411 and the high quality rotation contacts 412. This design makes use of reusable, high quality commercial components mated with a lower tolerance disposable component in which the connection need not be as high quality. However, the invention is not so limited.

**[036]** In another embodiment, not shown, a commercial coupling is not employed. Instead a custom coupling is constructed. The custom coupling may use brushes similar to those used in commercial rotational couplings or electrical motors. The brushes directly contact the annular bands. Other couplings and coupling techniques may be used.

**[037]** Fig 5 shows an instrumented K-wire 501 attached to a power drill 502. A similar setup can be employed for a manual drill or other tools. As shown, a K-wire 501 is inserted into chuck 503 of a cannulated drill. The drill 502 may be equipped with a coupling assembly 504 (e.g., the slip coupling assembly



described in Fig 4 above). The proximal portion of the slip coupling is attached to the drill so that it does not rotate with respect to the drill. The method of connection shown here, 505, is a brace or sleeve that fixes the proximal end of the slip coupling 506 to the drill at location say 507. Other couplings may be used. The length of the coupling (e.g., brace or sleeve 505) can be adjustable, if desired. The brace or sleeve prevents the proximal end of the slip-coupling from rotating. The guidewire, the proximal end of which is marked as 508 is inserted into the distal end of the slip coupling 509, which is locked to move (e.g. through the use of the hex head) with the guidewire. Thus, as the K-wire is drilled, electrical connections can continually sample the location and orientation of the position-indicating element in the K-wire during the drilling process without wires becoming twisted. When the K-wire is in position, it can be temporarily or permanently decoupled from the drill and slip coupling. It may also be cut or otherwise controlled in the usual manners that such devices are used.

**[038]** In another embodiment shown in Fig 6, a non-rotary coupling 601 may be used to achieve contact with the position-indicating elements embedded in the K-wire. This coupling slips over the head of the K-wire and achieves contact by providing a mechanism that engages the connection bands on the tracked K-wire. Alternatively, this coupling mechanism may be used if the K-wire is already in position (as it would be if the K-wire is being used as a dynamic reference or registration device). Or the coupling mechanism may be used instead of the slip coupling, for example, if the K-wire does not need to be rotated excessively, such as might be used with an intra-medullary nail

or similar device. Both the slip coupling and the non-rotary coupling may be used interchangeably.

**[039]** In an embodiment illustrated in Fig 6, numeral 602, a bar code, RFID chip, switch array or other indicator may be added to the K-wire. This indicator may incorporate information specific to the tool such as the serial number, date of manufacture, information specific to the position-indicating element, device-position-indicating element combination such as the position-indicating element to tip offset and/or other tool information. Various other information may also be included.

**[040]** In one embodiment, the diameter of the contact region may be the same as or smaller than the diameter of the K-wire. This permits existing devices such as cannulated screws or other instruments to be passed over the tracked K-wire in the same manner that it currently is done using conventional K-wires.

**[041]** In an alternate embodiment, shown in Figs 7A and 7B, the tracked K-wire 700 is constructed by drilling a hole along the shaft of a K-wire or fabricating one from a thick walled tube 704. The position-indicating element 706 and associated wiring 705 may be placed in the interior lumen of the tube 703, and connection bands added to the proximal end. A closed, sharp tip 702 may be welded onto hollow tube 704 at point 701 using, for example, a laser weld process. A drawing process may also be used to form the tip into a closed, pointed form.

**[042]** The tracked K-wire may be used as a guided instrument, as a device to facilitate registration, as a dynamic reference device, as a verification device

or otherwise. Examples of methods of registration, dynamic referencing, verification and other methods can be found in U.S. Patent Application No. 11/059,336 (published as U.S. Patent Publication No. 20050182319) by Glossop, which is hereby incorporated by reference herein in its entirety.

**[043]** To facilitate registration, the tracked K-wire may be drilled into bone (e.g., the vertebral body) as indicated in Fig 8. This can be done with or without image guidance or by using conventional image guidance such as X-ray. Once in place, markings on the K-wire or the shape of the K-wire are used in the manner described in U.S. Patent 6,785,571 to enable the location of the position-indicating elements to be determined. The method may proceed as follows. See flow chart 800.

**[044]** One or more K-wires may be drilled or attached into the bone (step 801). The K-wires are imaged (step 802). The imaging may be done using a scanner such as, for example, a computerized tomography (CT) scanner, a fluoroscope, biplane fluoroscope, or other device capable of determining the location of the position-indicating elements in the K-wires or indicator markings whose position and orientation is known relative to the position-indicating element. In one embodiment (described above), the markings may be on the K-wire in a known location relative to the position-indicating element. In one embodiment, the markings may be on the position-indicating element itself.

**[045]** Next, the images are used to determine the location of the position-indicating element in image space (Step 803) (i.e., in the coordinate system intrinsic to the images). In some embodiments this can be performed



automatically using a computerized segmentation process, in other embodiments this may be performed manually. The location of the position-indicating element in patient space (i.e., the coordinate system intrinsic to the position sensor) is then determined through sampling the position and orientation of the position indicating elements with the position sensor (Step 804). A registration process (step 805) may also be performed. Various registration techniques are known. In one embodiment, a singular valued decomposition is used. In another embodiment, an iterative closest points technique is used. Other techniques can be used.

**[046]** Navigation (e.g., using a tracked tool) may then be commenced (Step 806). Navigation may include using a tracked tool (e.g., a tool that contains a position-indicating element) in the position sensor volume. The patient space coordinates may be converted (e.g., using the registration of step 805) to image space and the location and orientation of the tracked tool may be displayed on the images. In one embodiment, the tracked tool can be another K-wire. In another embodiment, the tracked tool can be a probe or any other device that contains one or more position-indicating elements.

**[047]** Dynamic referencing may be used to compensate for bone (or other) movement. In practice, it can also be used to track an individual bone or bone fragment; the method of use of the invention for this purpose is essentially the same in these cases. To facilitate dynamic referencing one or more of the tracked K-wires is placed into the bone as detailed in Fig 9 in flowchart 900.

**[048]** As shown in Fig. 9 one or more of the K-wires may be drilled into the bone or bone fragment. The number used depends on the number of

degrees of freedom (DOF) that the position-indicating element and position sensor are capable of measuring, the number of position-indicating elements present in the K-wire, and the accuracy required. Normally the best accuracy is obtained by tracking the bone in 6 degrees of freedom, however, this may not be required for some applications (e.g., in which some components of motion are small). If 6 DOF position-indicating elements are used, only a single K-wire is required, as the position-indicating element embedded in the bone measures three translations and three rotations. If 5 DOF position-indicating elements are used, at least 2 K-wires are required to fully describe the motion in 6 DOF. If 3 DOF position-indicating elements are used, at least 3 are required to describe the motion in 6 DOF. In decision box 902, if enough DOF can be measured using a single K-wire, then it is then possible to directly track the motion of the bone (in the required number of DOF) to which it is attached as indicated in box 908. If instead, multiple K-wires are used, they are drilled into the object to be tracked. To determine extra DOF, at least two approaches can be used. In decision box 903, if an imaging method is to be used, the bone or fragment with K-wires is imaged as indicated in 904. Using methods described above (or otherwise), the locations and/or orientations of the position-indicating elements is determined in image space as indicated in box 905. Using the location and/or orientation information, methods are employed in box 906 to create a 6 DOF "rigid body" whose motion can be determined and tracked in box 908.

**[049]** If in decision box 903 an image free method is to be used, the positions of the position-indicating elements are determined by directly measuring the



locations of each of the position-indicating elements embedded in the bone using the K-wire as indicated in box 907. Using the location and/or orientation information, methods are employed in box 906 to create a 6 DOF "rigid body" whose motion can be determined and tracked in box 908.

**[050]** Initial implantation of K-wires for use in dynamic referencing or for registration may be performed using a live imaging device such as, for example, fluoroscopy, ultrasound, or other imaging apparatus, or may be performed using an initial "temporary registration." In this scenario, a temporary registration may be performed using, for example, a paired point surface registration or a skin patch, as described in U.S. Patent Application No. 11/271,899, by Glossop, entitled "Integrated Skin-Mounted Multifunction Device for use in Image Guided Surgery," which is hereby incorporated by reference herein in its entirety. This temporary registration may then be used to roughly guide the K-wires that will be used for the high fidelity registration into place. Similarly, a "temporary dynamic referencing device" such as, a skin patch may be used to help implant the K-wires that may be used for the high fidelity dynamic referencing or fragment tracking.

**[051]** The tracked K-wire can be used as a guided instrument as indicated in Fig 10, flowchart 1000. In an embodiment, the bone is first imaged (Step 1001). Next it is registered (Step 1002). This may be done using a number of different techniques known in the art, in addition to the embodiment described herein. The accuracy of the registration may then be verified using technologies known in the art. Examples of such verification materials and methods may be found in U.S. Patent Application No. 11/059,336 (published



as U.S. Patent Publication No. 20050182319) by Glossop, which is incorporated by reference herein in its entirety. Finally, the tracked K-wire is inserted into the drill and while watching the progress of the drill on the images displayed on the computer system, it is drilled into the bone as shown in 1003. The registered image guided surgery system is used to position and orient the K-wire and monitor its location and orientation as it is drilled into the bone.

**[052]** In one embodiment, the wire may be inserted into a cannulated drill onto which the slip coupling mechanism is attached. The wire may be seated so that the contact points of the K-wire electrically connect with the rotating part of the slip coupling and the hexagonal portion of the K-wire is engaged with the slip coupling. The chuck of drill is tightened. The connector cable of the coupling is connected to the position sensor. The drill and K-wire are brought into the volume and drilling is commenced. The position and orientation of the position-indicating element is displayed in real time as the drilling occurs. In some embodiments, the display may only be activated when drilling stops.

**[053]** The device described can be configured in numerous variations, including a version where the contact rings on the K-wire are used as rotational contact members as mentioned previously. Different methods of ensuring movement of the encoder shaft may also be employed beside the hex head. These may include square heads, triangular heads, stepped heads etc. In some configurations, the K-wire contacts may act as partially rotating,

relying on friction alone. In such cases part of the slip will occur at the K-wire contacts and part at the slip-coupling contacts.

**[054]** Partial slippage at the K-wire contacts is permitted as it is not required that rotational coupling should be 1 K-wire rotation to 1 slip coupling rotation. Coupling can also take place at any location along the K-wire shaft. In cases where wireless position-indicating elements are employed, the slip coupling is obviously not required.

**[055]** While various embodiments have been described on connection with a K-wire, the principles of the invention can be applied to other devices as well. For example, the invention can be applied to a screw, drill bit, pin, stylette, guidewire, and other shaft like devices or other devices. In forms that employ wireless position-indicating elements, the same form of the elongated member can be used but, the elongated member itself or conductive elements placed within and attached to the position-indicating element can act as an antenna to broadcast the signal from the wireless position-indicating element. Other embodiments and alternatives may be used.

**[056]** Other embodiments, uses and advantages of the invention will be apparent to those skilled in the art from consideration of the specification and practice of the invention disclosed herein. The specification should be considered exemplary only, and the scope of the invention is accordingly intended to be limited only by the following claims.

## Claims

1. A device for image guided surgery that includes an elongated member for insertion in an anatomical body and a removable coupling mechanism, the elongated member comprising:
  - a. at least one electromagnetic position-indicating element, located in the elongated member and capable of providing the position and orientation of the location of the position-indicating element;
  - b. at least one conductive lead-wire from which signals are carried along at least a portion of the length of the elongated shaft to a proximal end;
  - c. a plurality of connection bands associated with the elongated member, that connect the at least one conductive lead-wire to an electromagnetic position sensor system.
2. The device of claim 1, where the connection bands facilitate axial rotation of the elongated member while maintaining contact with the electromagnetic position sensor system.
3. The device of claim 1, wherein the connection bands connect the at least one conductive lead wire to the electromagnetic position sensor system via a rotary slip coupling that permits rotational movement of the elongated member while maintaining electrical contact between the electromagnetic sensor system and the position indicating element.



4. The device of claim 1, where a tip of the elongated member includes a sharp point.
5. The device of claim 1, where at least part of the elongated member is threaded.
6. The device of claim 1, where the at least one position-indicating element contains radio-opaque markings.
7. The device of claim 6, wherein the radio-opaque markings further form a pattern that can be used to encode information relating to the elongated member.
8. The device of claim 7, wherein the information can be decoded using X-rays.
9. The device of claim 1, wherein the elongated member includes an integrated identification system encoding information relating to the elongated member and the connector is capable of reading the identification information.
10. The device of claim 9, where the identification information includes at least one of:

- a. a pattern of dark and light regions that effectively constitute barcode or other similar code and that can be optically determined;
- b. a plurality of switches that can be used to construct a binary number that encodes information;
- c. a memory device; or
- d. an RFID device.

11. The device of claim 1, wherein the conductive elements are of the same or smaller diameter than the remainder of the elongated member.

12. A method for registration of a portion of an anatomy of a patient using an instrumented K-wire that includes at least one electromagnetic position-indicating element, located in an elongated member that is capable of providing its position and orientation as patient space data, the method comprising:

securing the K-wire to the anatomy of the patient;

imaging the anatomy and the secured K-wire to produce one or more images;

gathering image space data regarding the location of the at least one position-indicating element on the one or more images;

gathering the patient space data by sampling the location of the at least one electromagnetic position indicating element within the anatomy of the patient; and

calculating a registration of the portion of the anatomy of the patient using the image space data and the patient space data.

13. A method for dynamic referencing a portion of an anatomy of a patient using at least one instrumented K-wire that includes at least one electromagnetic position-indicating element, located in an elongated member that is capable of providing its position and orientation as patient space data, the method comprising:

securing the at least one instrumented K-wire to the portion of the anatomy of the patient; and

tracking the portion of the anatomy of the patient by tracking the position and orientation of the at least one position indicating element.

14. The method of claim 13, wherein tracking the portion of the anatomy further comprises updating a registration of the portion of the anatomy utilizing information relating the tracking of the portion of the anatomy.

15. The method of claim 13, wherein securing the at least one instrumented K-wire further comprises determining a desired number of degrees of freedom, and determining a number of instrumented K-



wires necessary to measure the desired number of degrees of freedom.

16. The method of claim 13, wherein securing the at least one instrumented K-wire further comprises:

imaging the portion of the anatomy of the patient, including the at least one secured instrumented K-wire to produce one or more images;

determining, from the one or more images, location and orientation of the at least one position-indicating element for each of the at least one secured instrumented K-wires to obtain image space data; and

determining a six degree of freedom rigid body using the image space data, wherein the motion of the rigid body can be determined and tacked,

wherein tracking the position and orientation of the at least one position indicating elements further comprises tracking the rigid body.

17. The method of claim 13, wherein securing the at least one instrumented K-wire further comprises:

measuring the position and location of the at least one position indicating element of each secured instrumented K-wire within the portion of the anatomy of the patient to obtain patient space data; and

determining a six degree of freedom rigid body using the patient space data, wherein the motion of the rigid body can be determined and tacked,

wherein tracking the position and orientation of the at least one position indicating elements further comprises tracking the rigid body.

18. A method for navigating an instrumented K-wire to a bone or bones, wherein the at least one instrumented K-wire includes at least one electromagnetic position-indicating element, located in an elongated member that is capable of providing its position and orientation as patient space data, the method comprising:

imaging the bone or bones to obtain image space data;

receiving patient space data regarding the bone or bones from a registration device equipped with one or more position indicating elements;

calculating a registration by registering the image space data to the patient space data;

navigating the instrumented K-wire to the bone or bones using an icon of the instrumented K-wire displayed on an image of the bone or bones, wherein the registration is used to display the icon of the instrumented K-wire on the image of the image of the bone or bones;  
and

securing the instrumented K-wire to the bone or bones.

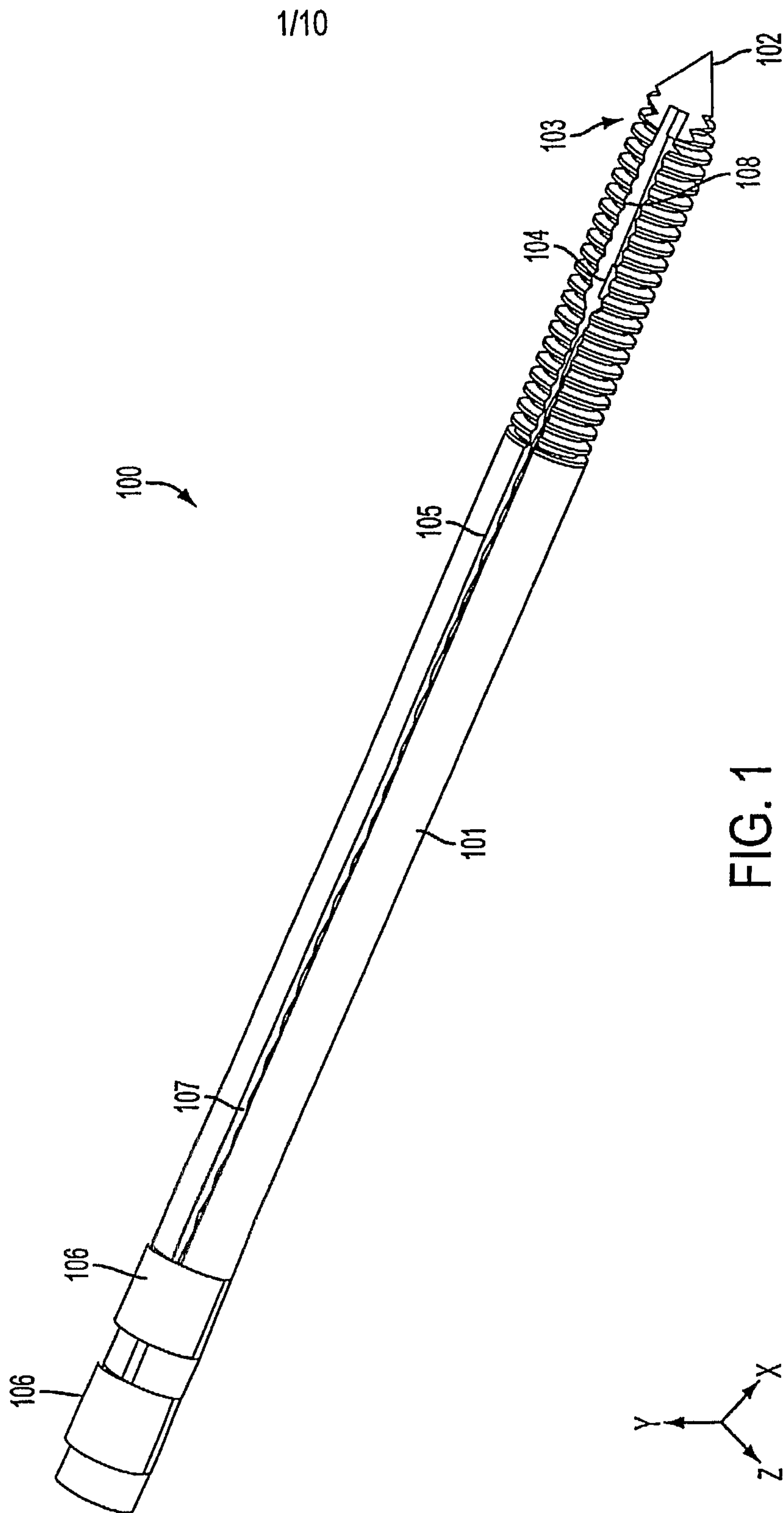

FIG. 1



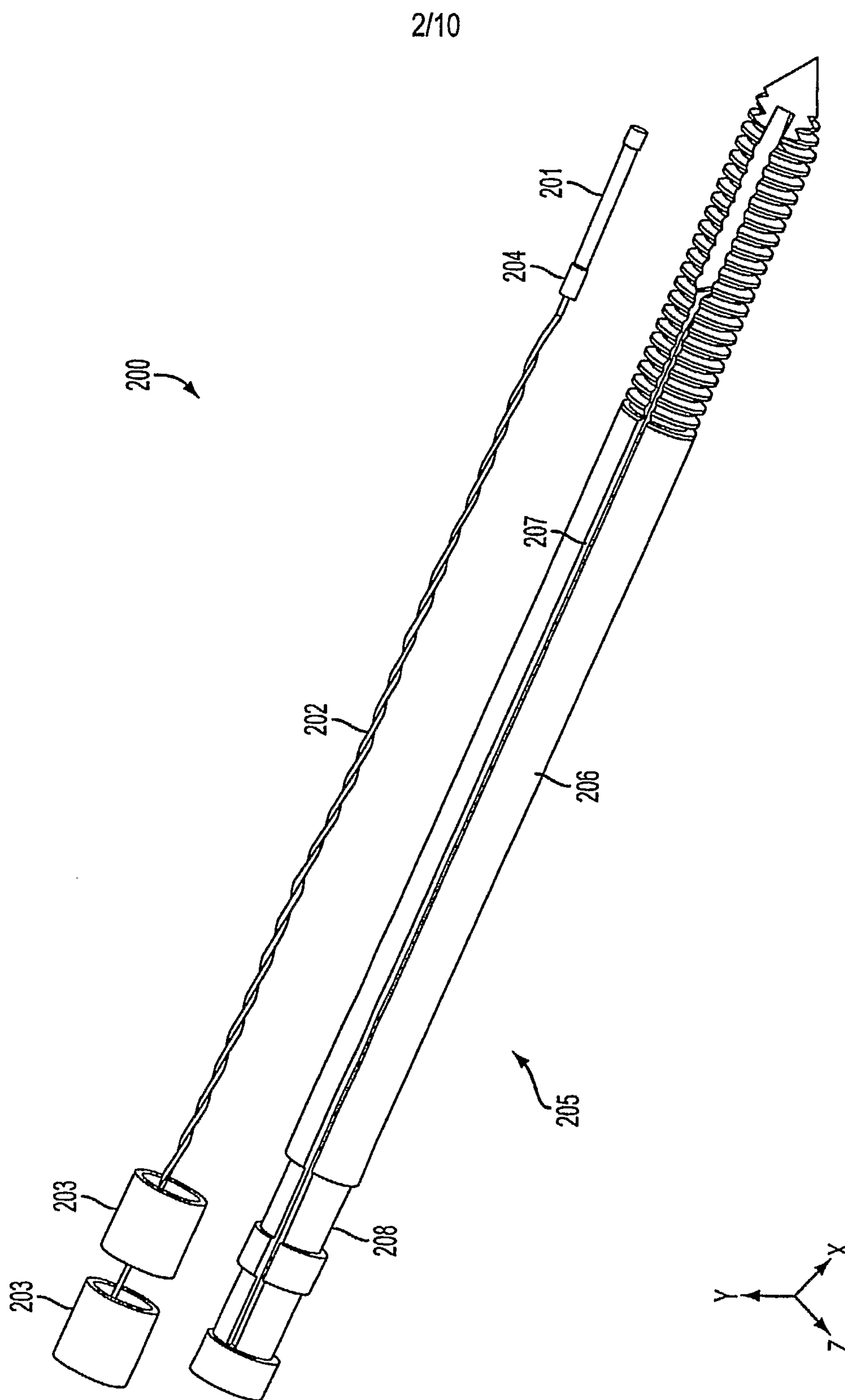

FIG. 2

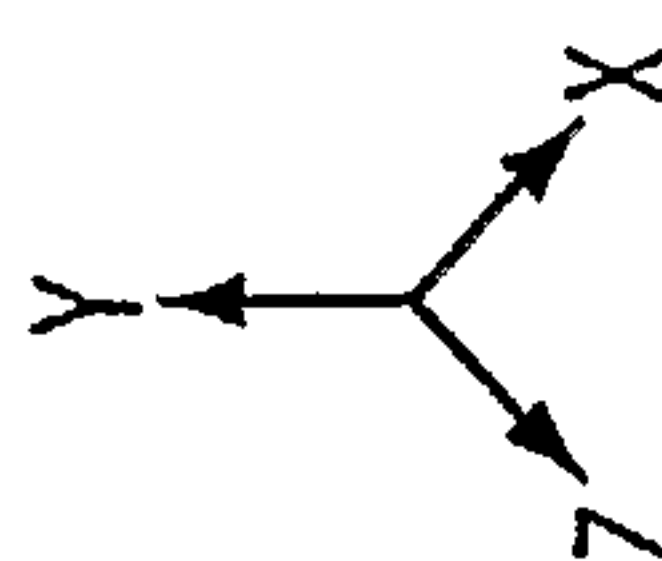
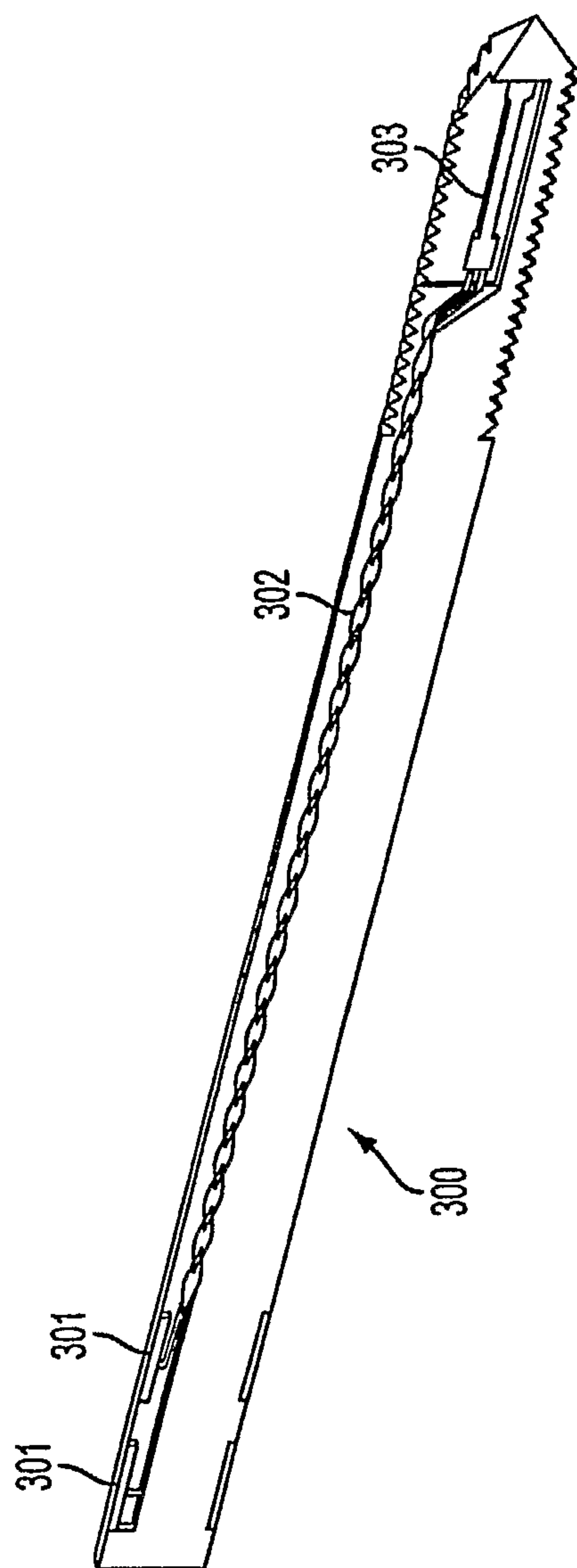

FIG. 3

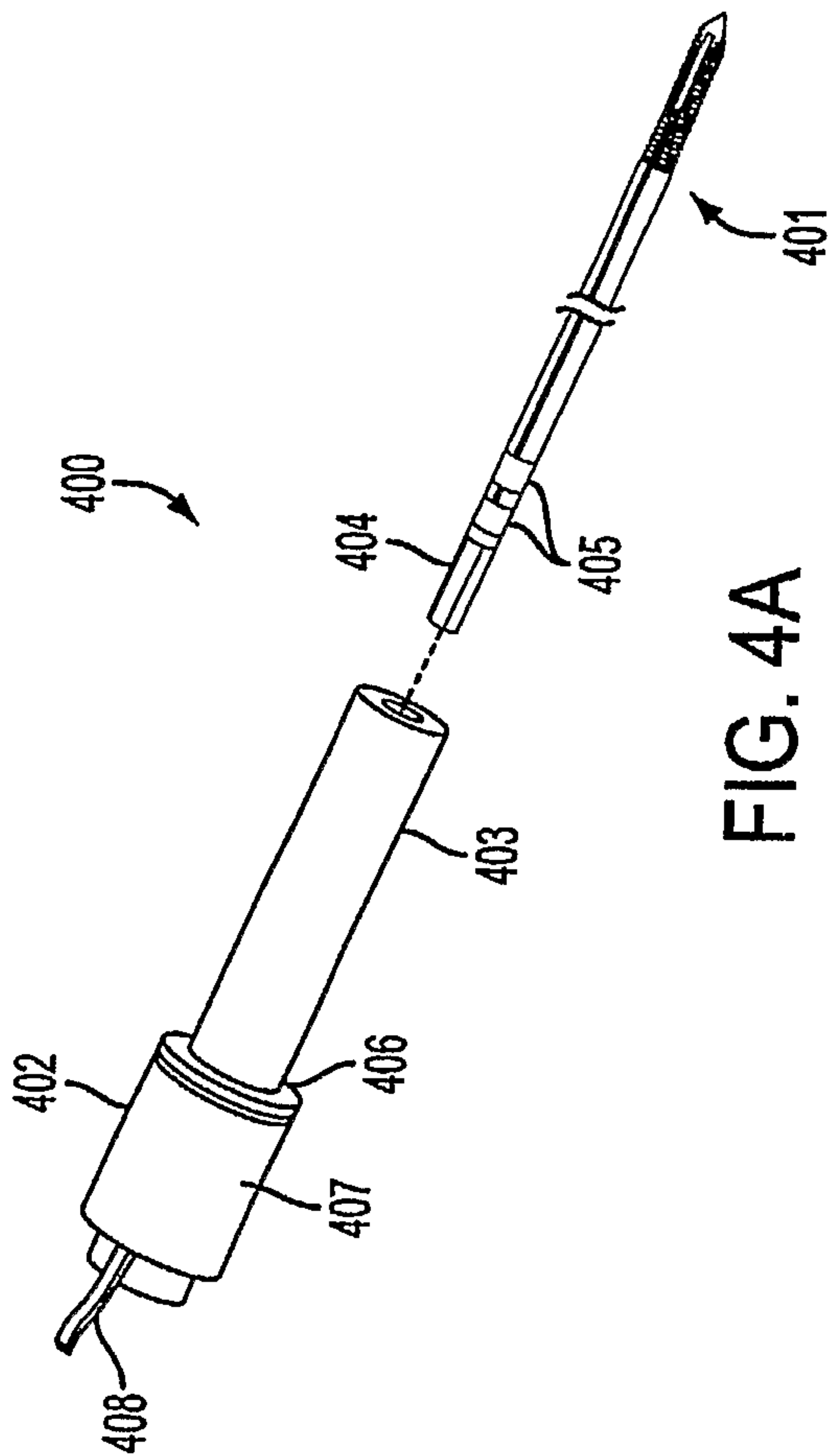

FIG. 4A

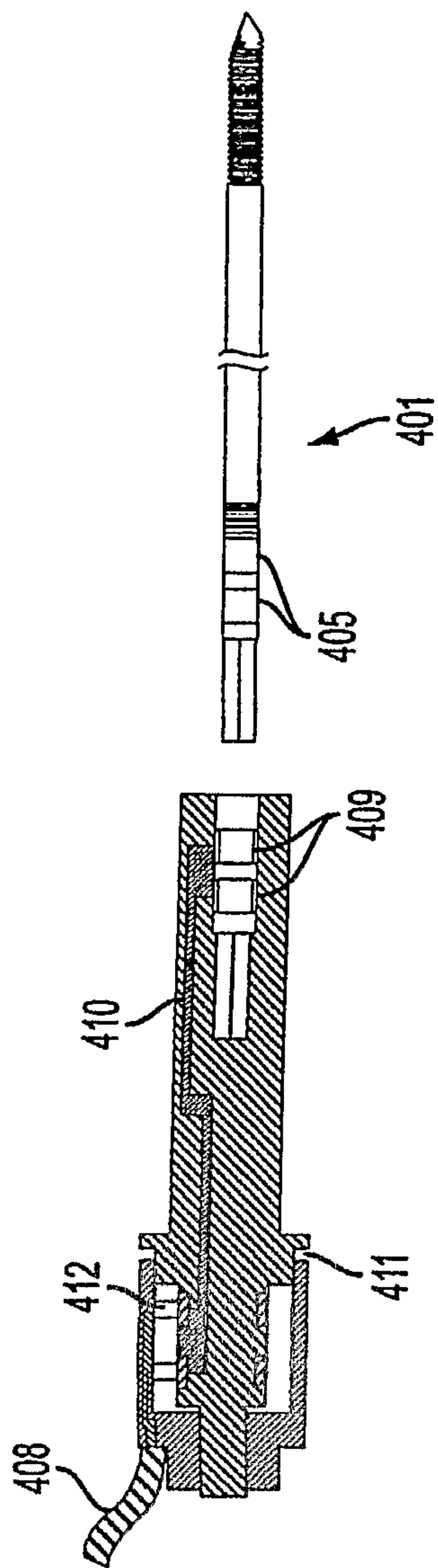

FIG. 4B



5/10

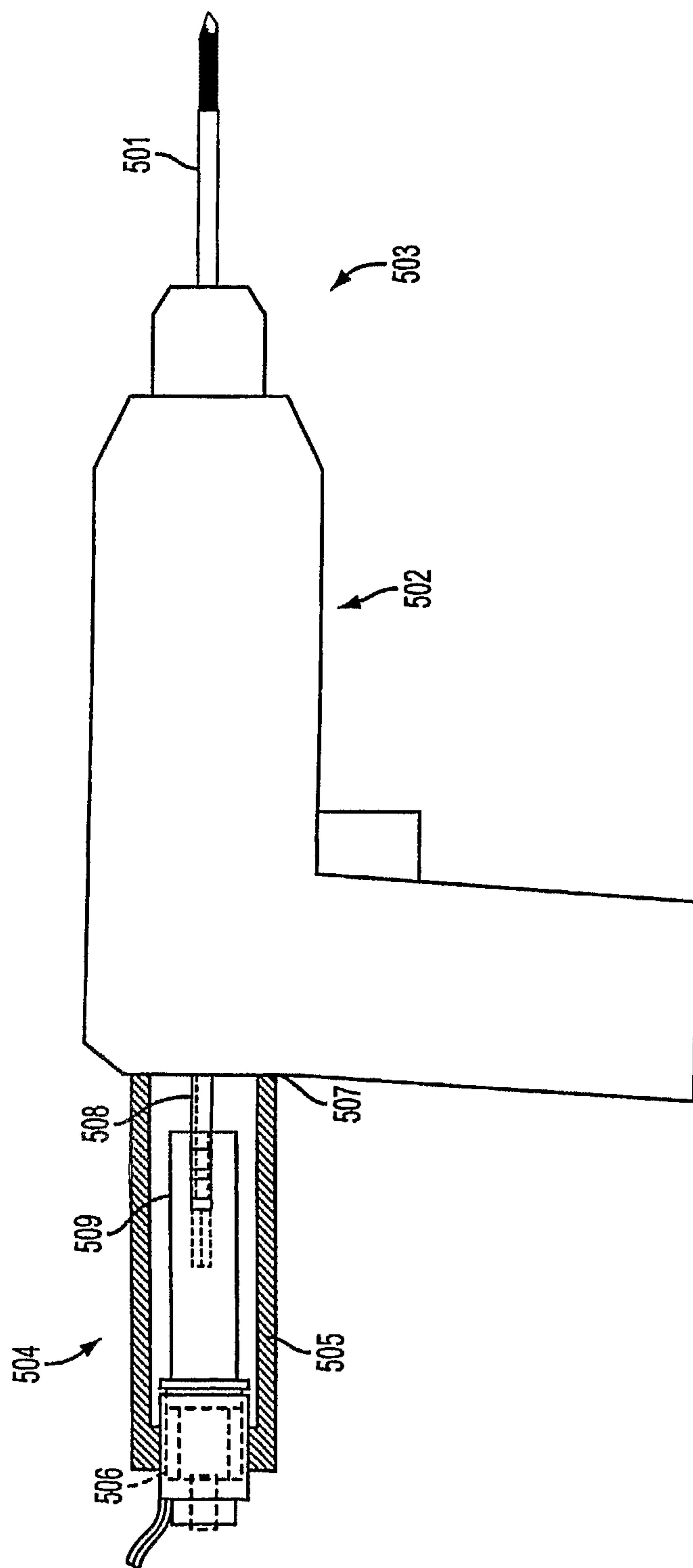

FIG. 5

6/10

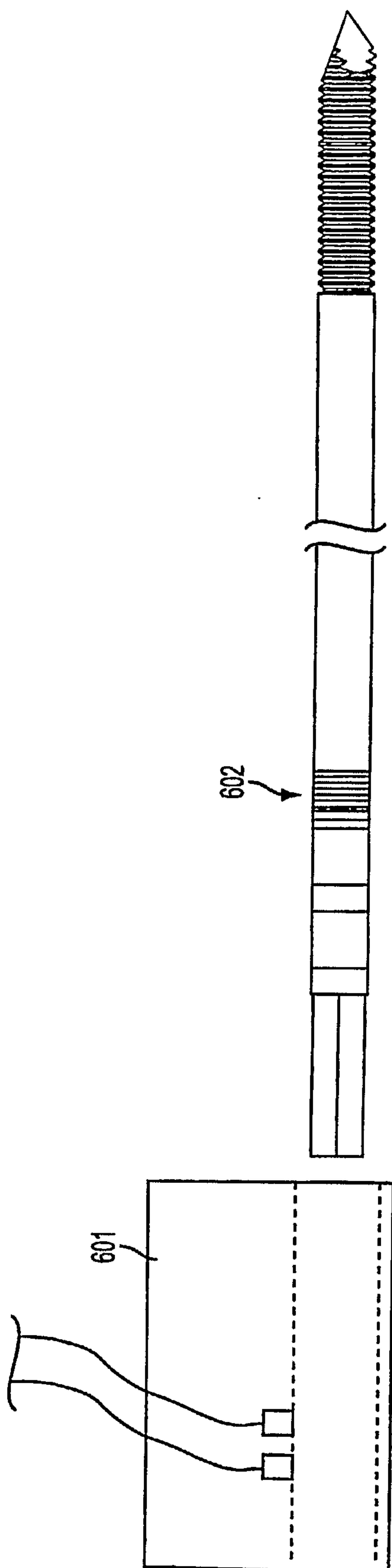

FIG. 6

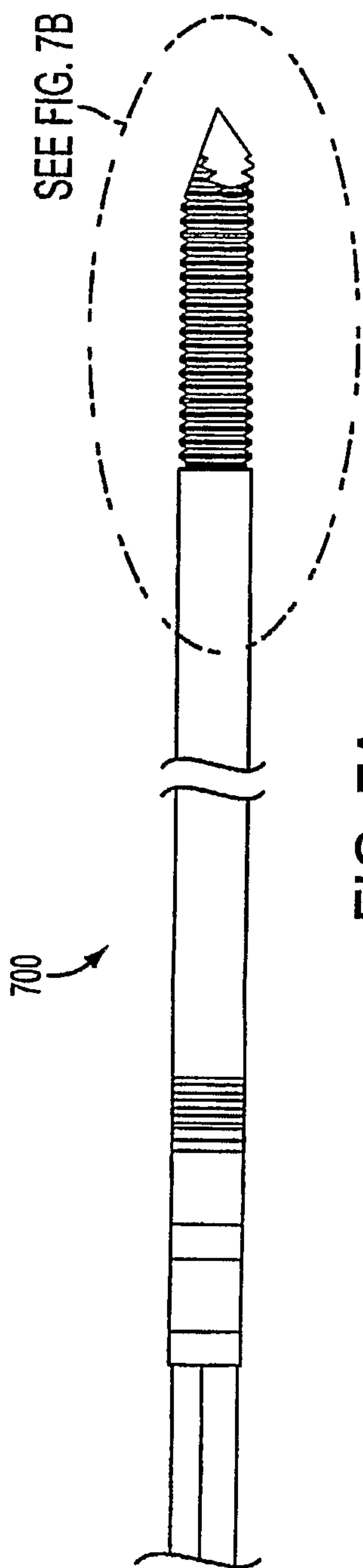

FIG. 7A

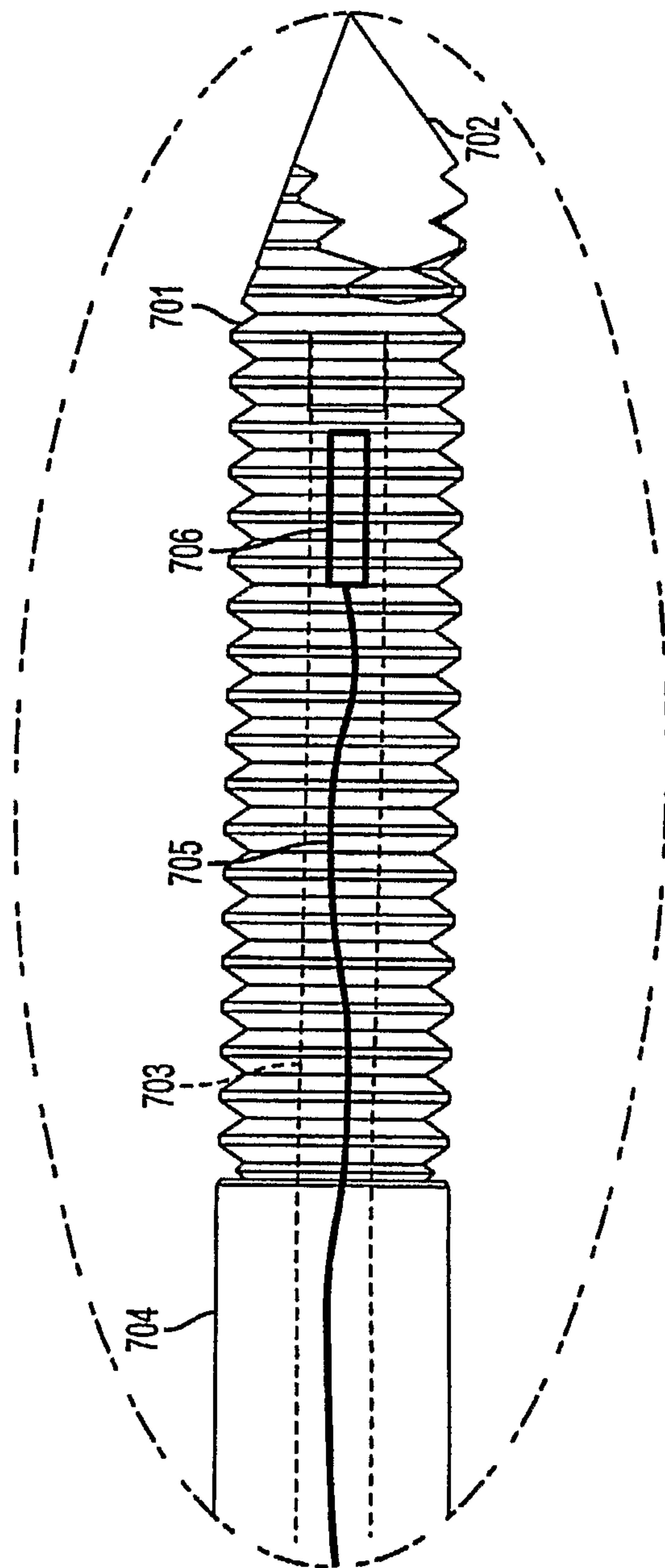

FIG. 7B



8/10

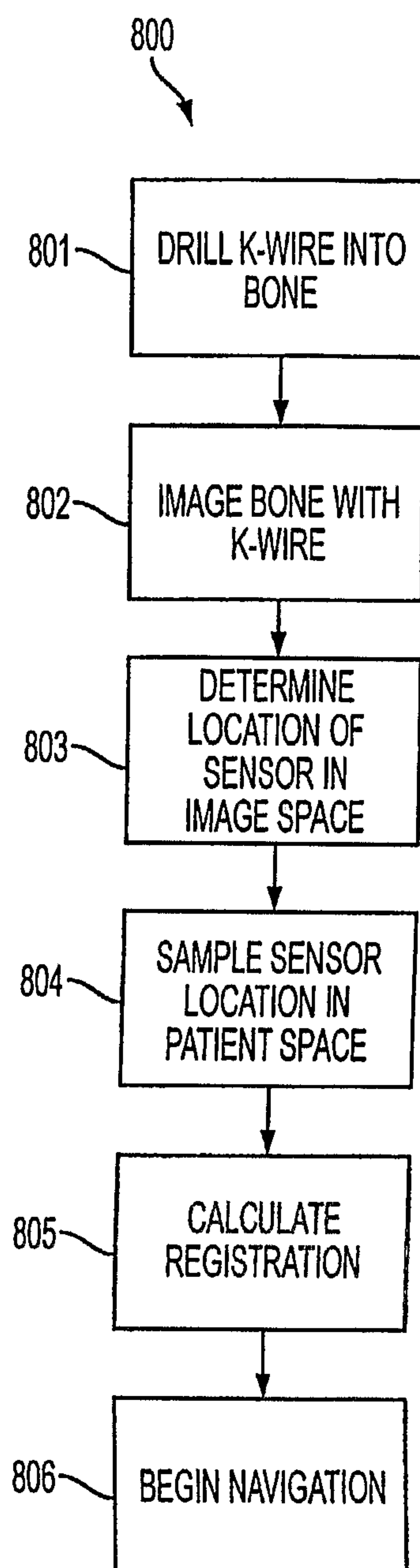

FIG. 8

9/10

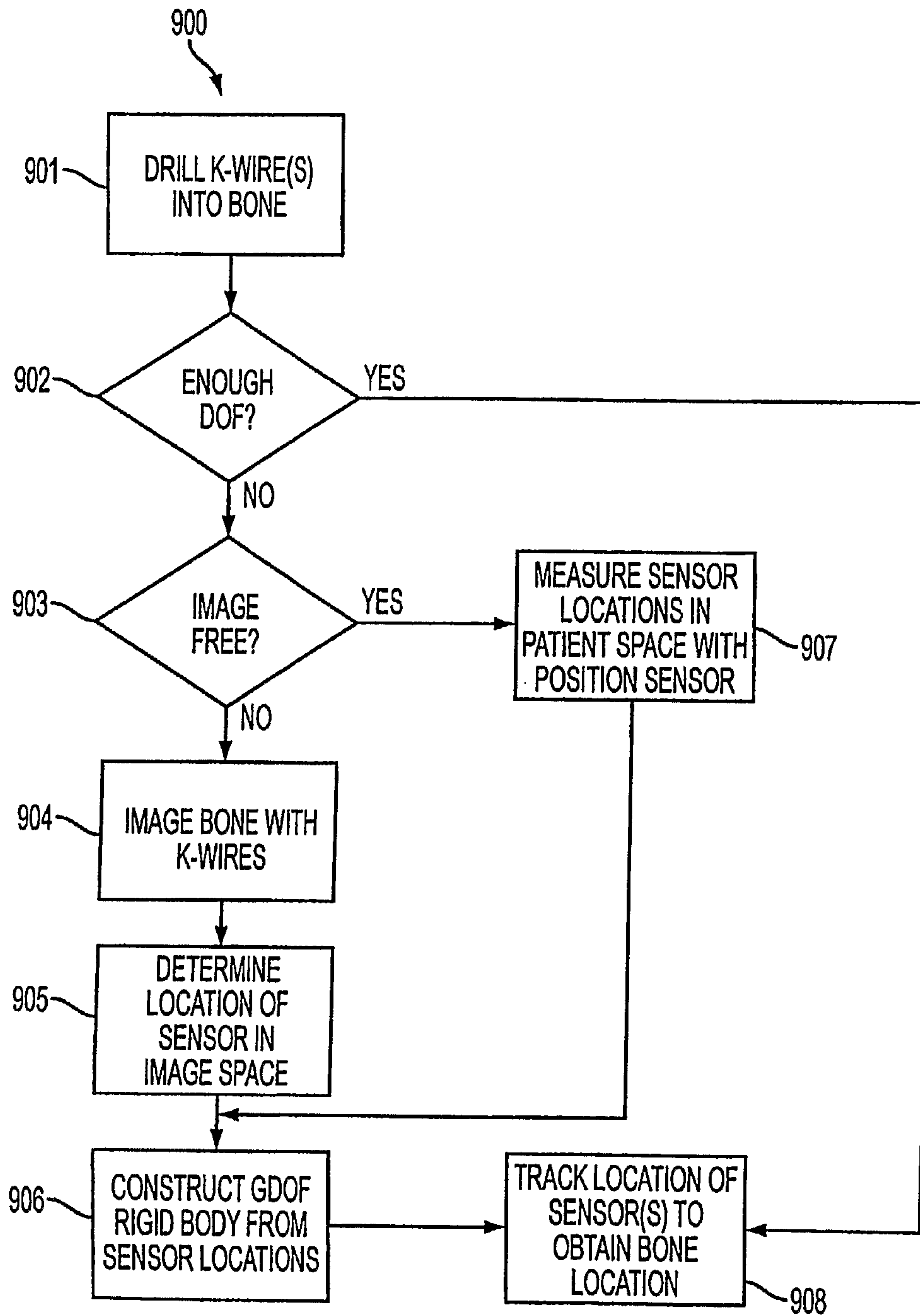

FIG. 9

10/10

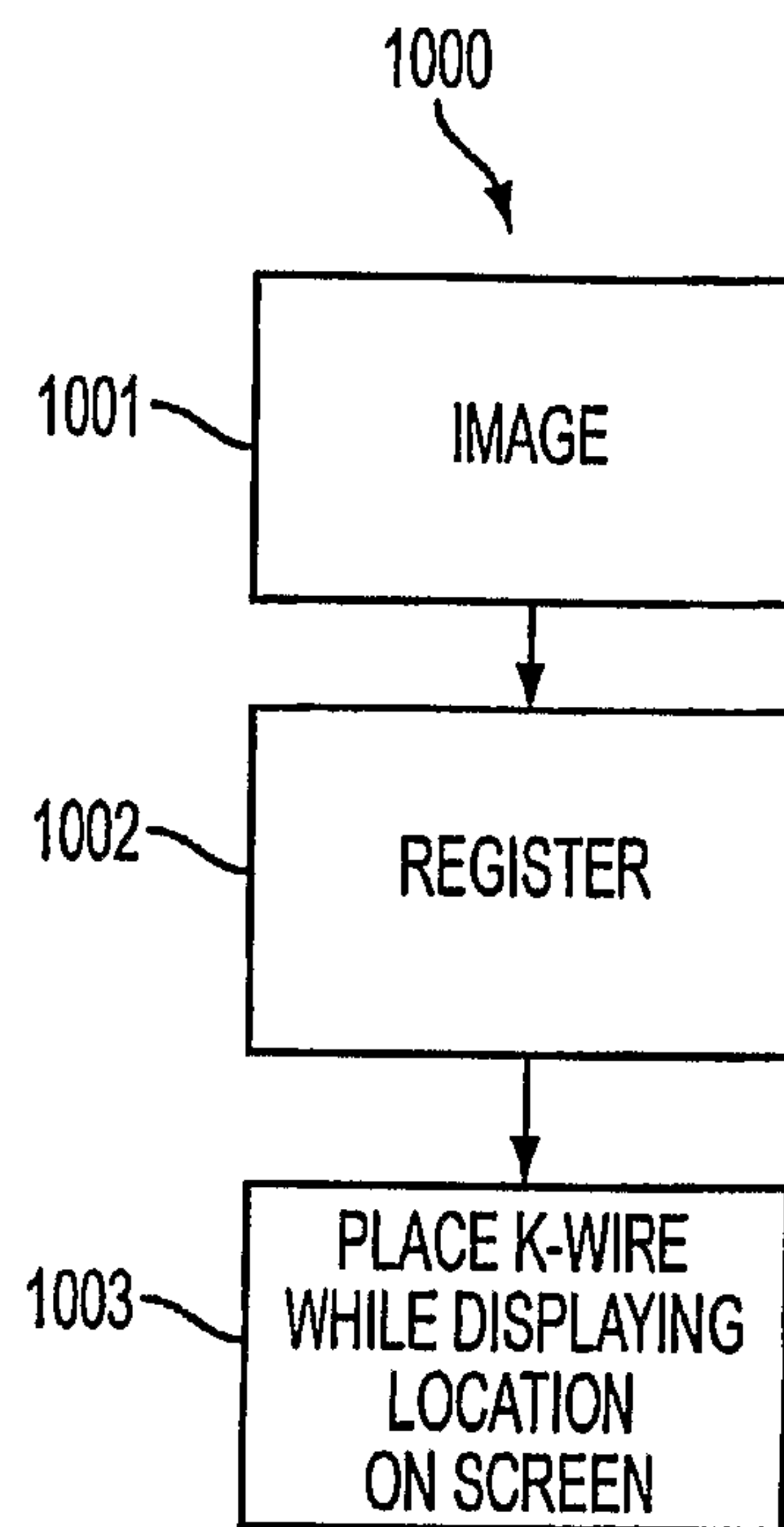

FIG. 10



