



US 20090193831A1

(19) **United States**
(12) **Patent Application Publication**
KIM et al.

(10) **Pub. No.: US 2009/0193831 A1**
(43) **Pub. Date: Aug. 6, 2009**

(54) **AIR CONDITIONER**

Feb. 5, 2008 (KR) 10-2008-0011798

(76) Inventors: **Jung Hoon KIM**, Seoul (KR); **Kak Joong Kim**, Seoul (KR); **Yong Sang Yoon**, Seoul (KR); **Dong Soo Moon**, Seoul (KR); **Si Young Oh**, Seoul (KR)

Publication Classification

(51) **Int. Cl.**
F25D 23/00 (2006.01)
F25D 17/06 (2006.01)
F25B 39/02 (2006.01)
F04D 29/38 (2006.01)
(52) **U.S. Cl.** **62/259.1**; 62/426; 62/515; 416/189

Correspondence Address:
KED & ASSOCIATES, LLP
P.O. Box 221200
Chantilly, VA 20153-1200 (US)

(57) **ABSTRACT**

An air conditioner is provided. A heat exchange unit of the air conditioner may include a blower fan that generates air flow within a housing, and a first shroud that guides the air flow generated by the blower fan to an outside of the cabinet. A second shroud may be coupled to an upstream end of the first shroud. An outer peripheral surface of a transverse section of the second shroud may be curved so as to stabilize air flow generated by the blower fan.

(21) Appl. No.: **12/363,163**

(22) Filed: **Jan. 30, 2009**

(30) **Foreign Application Priority Data**

Jan. 30, 2008 (KR) 10-2008-0009713

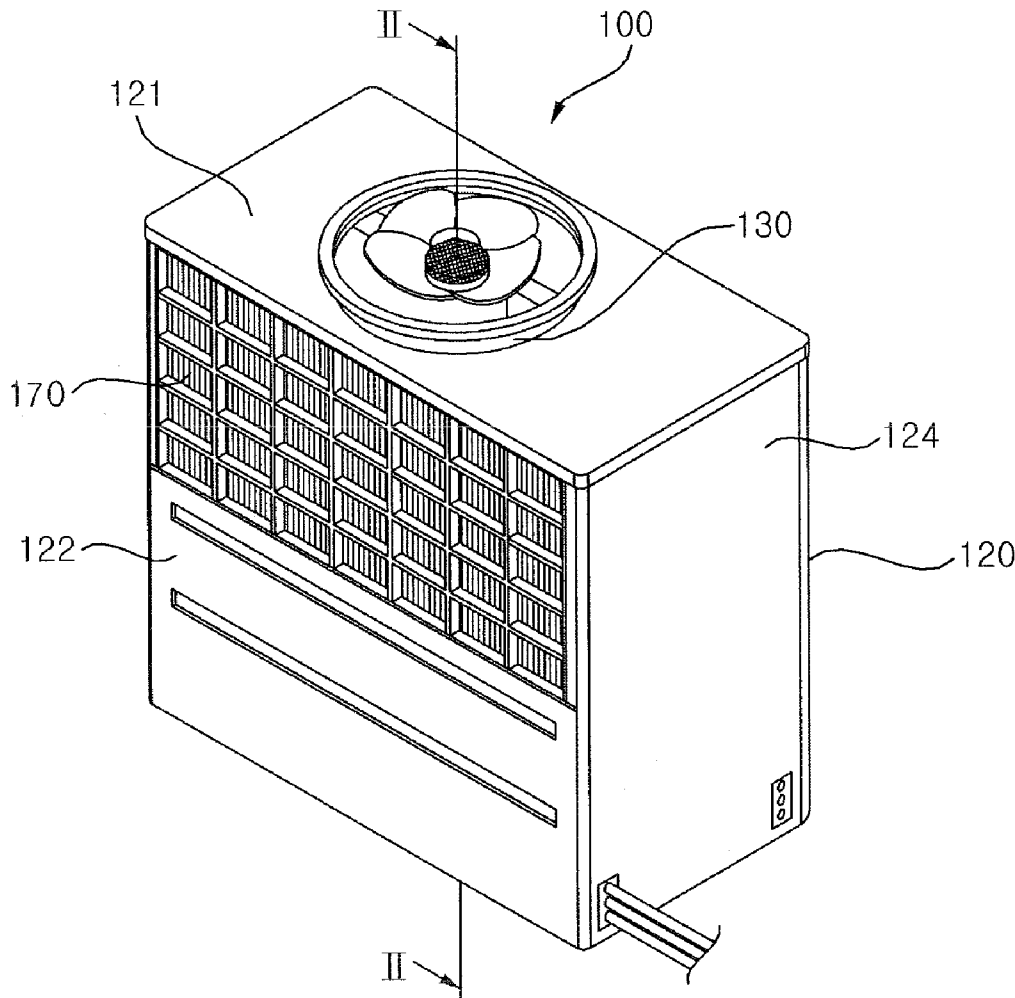

FIG. 1

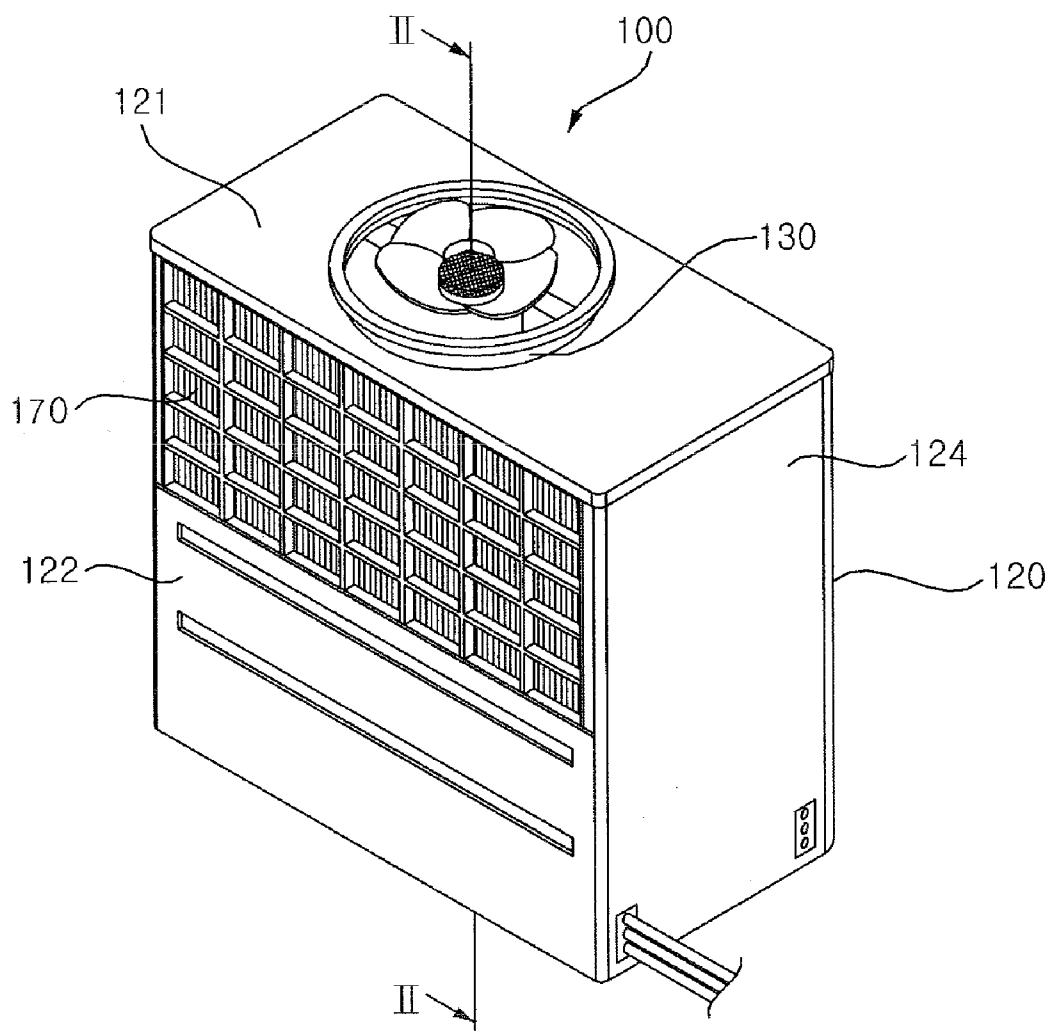

FIG. 2

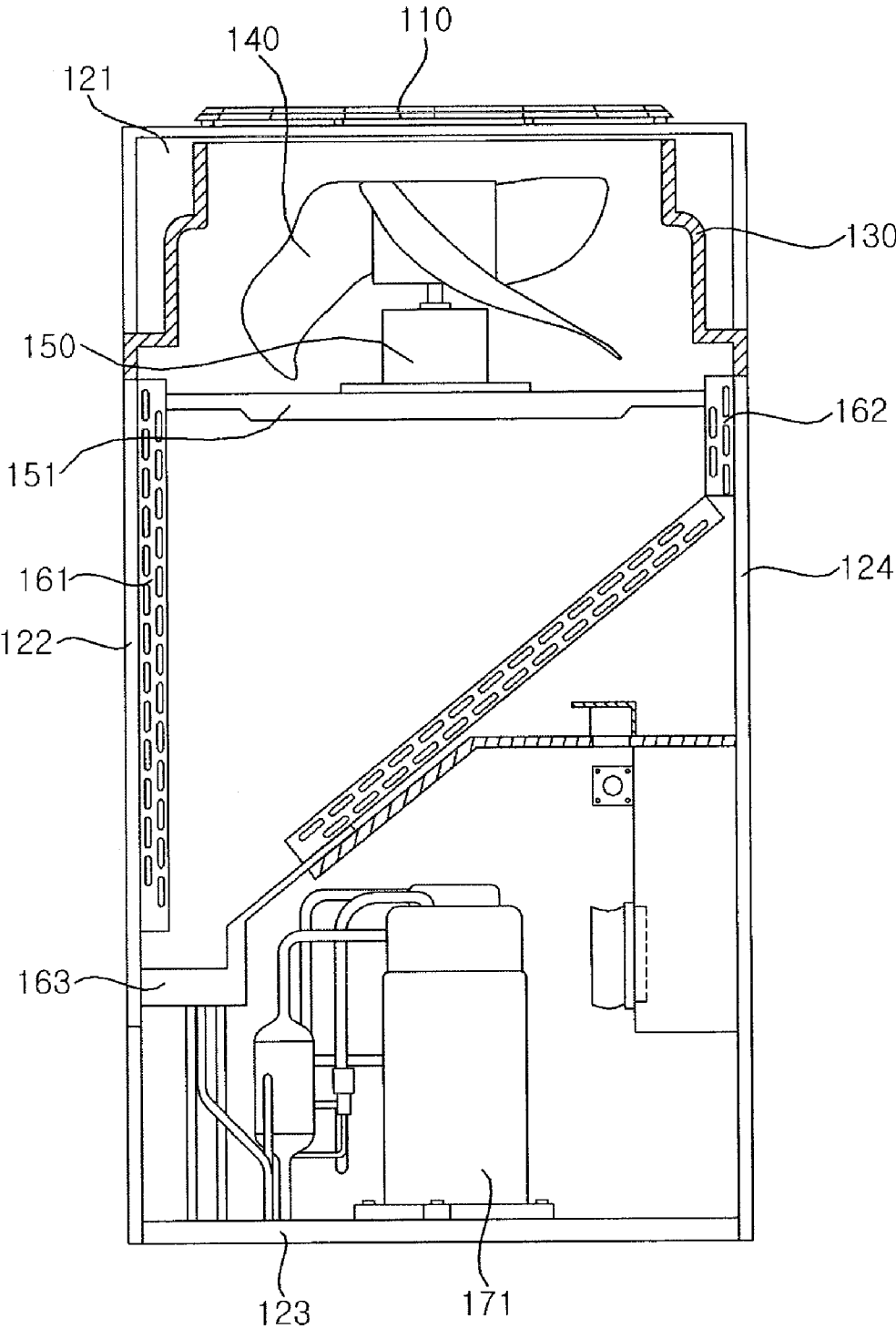

FIG. 3

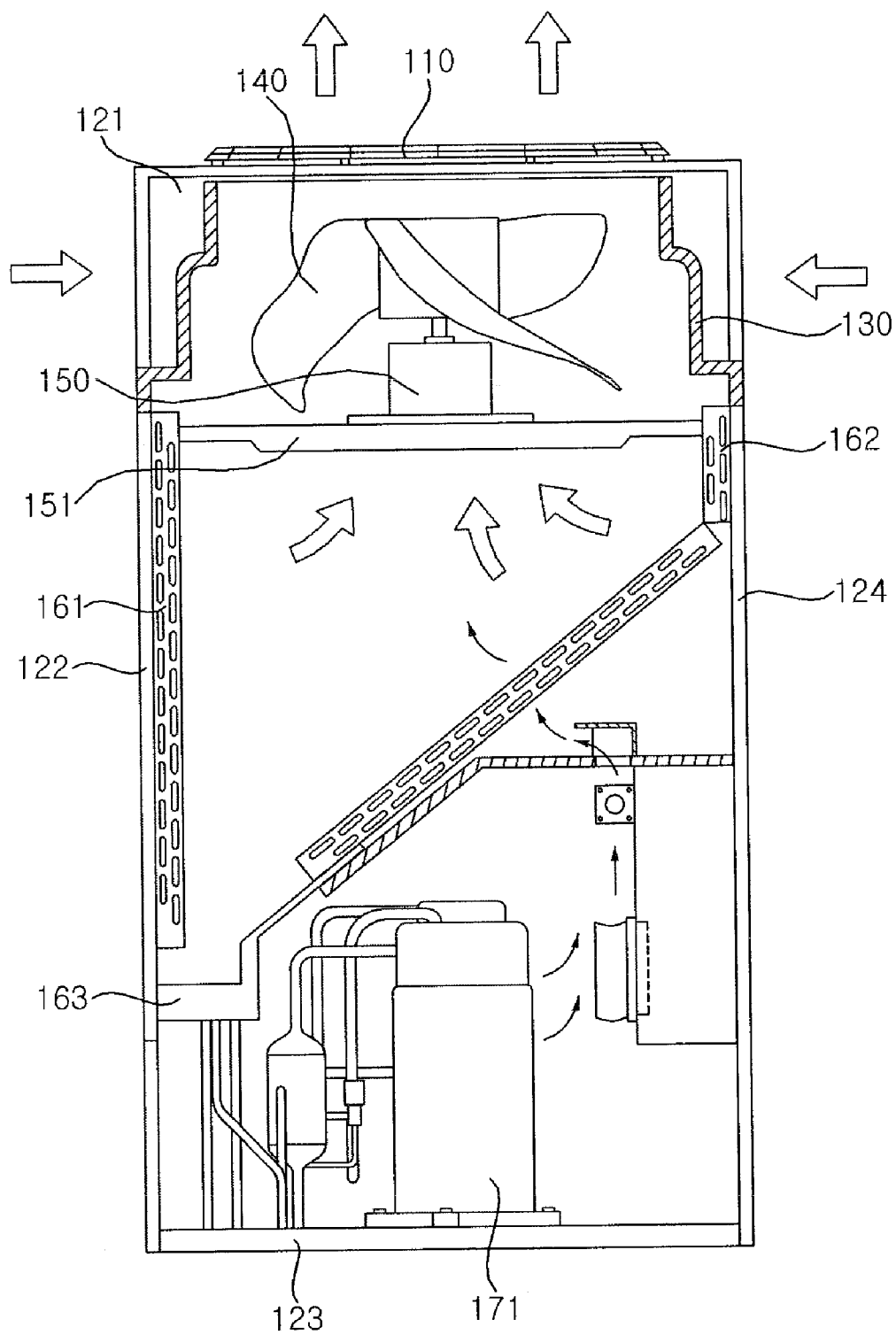

FIG. 4

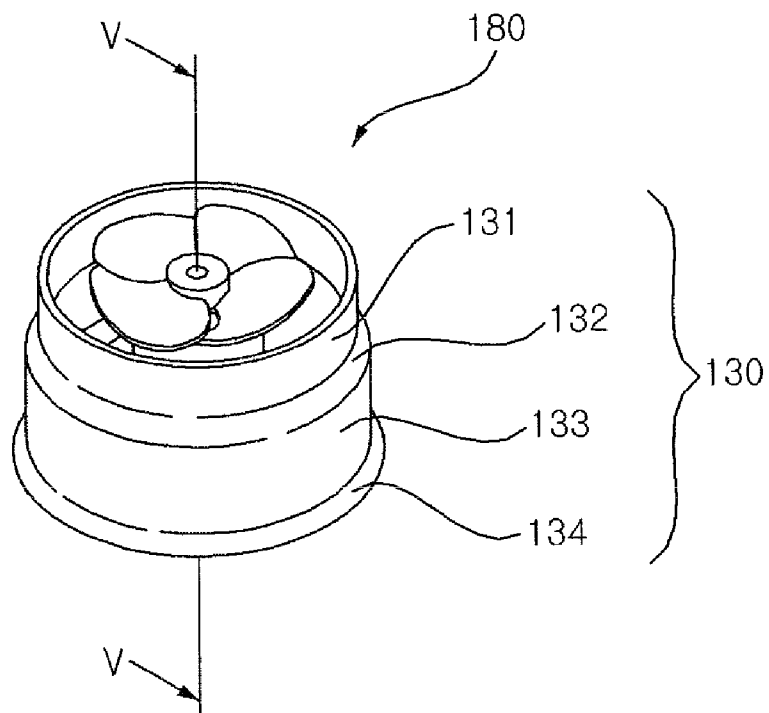

FIG. 5

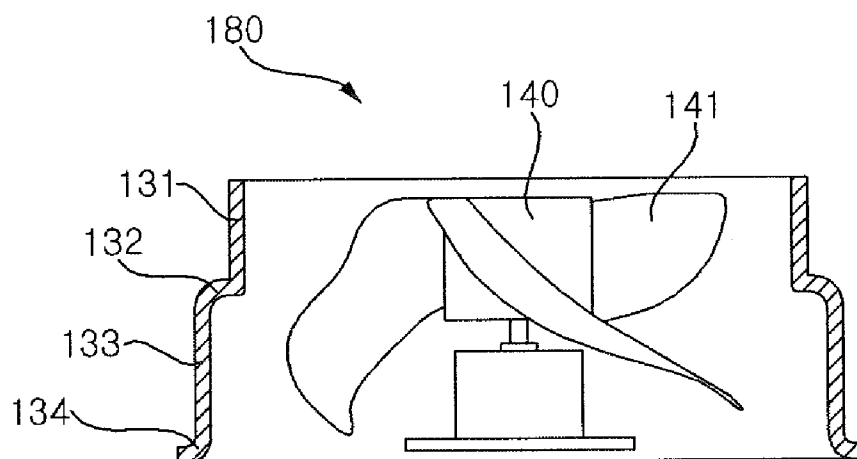

FIG. 6

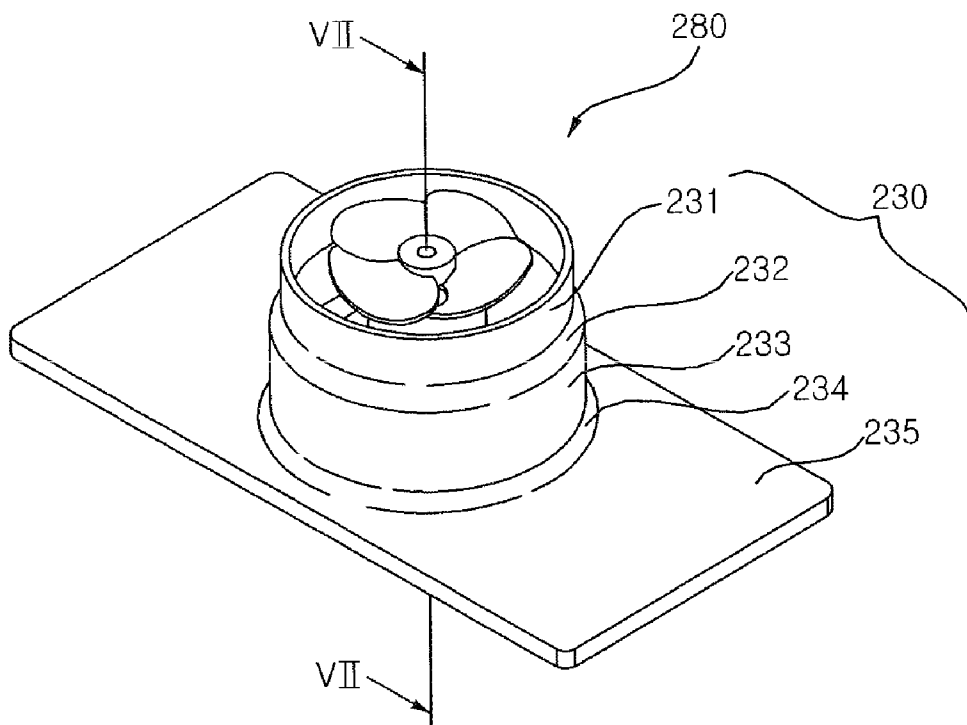

FIG. 7

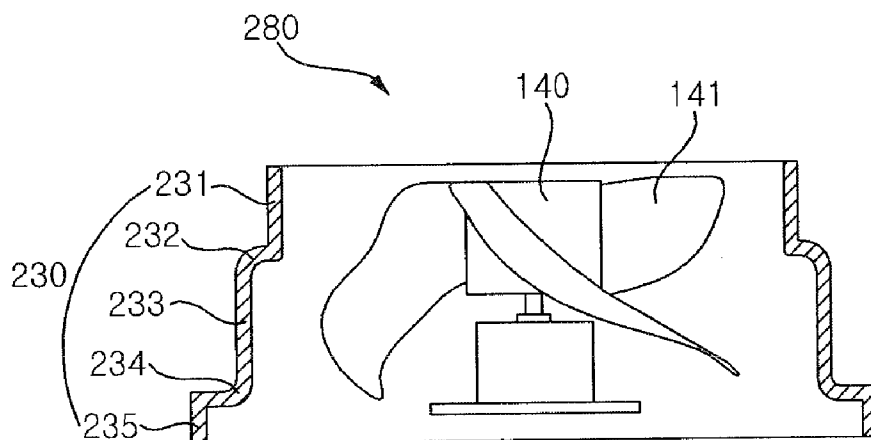

FIG. 8

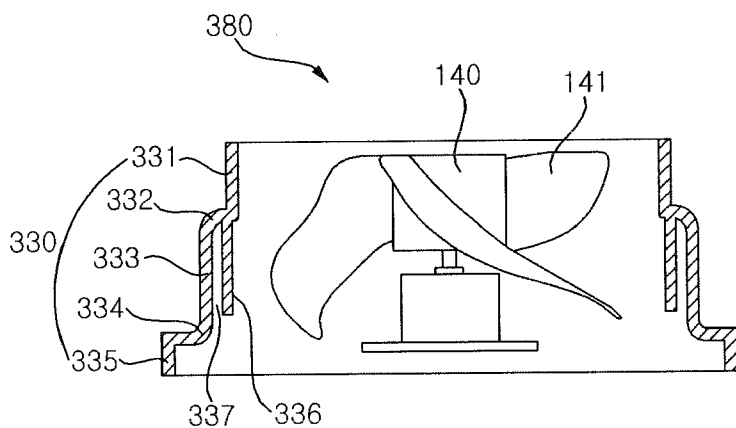

FIG. 9

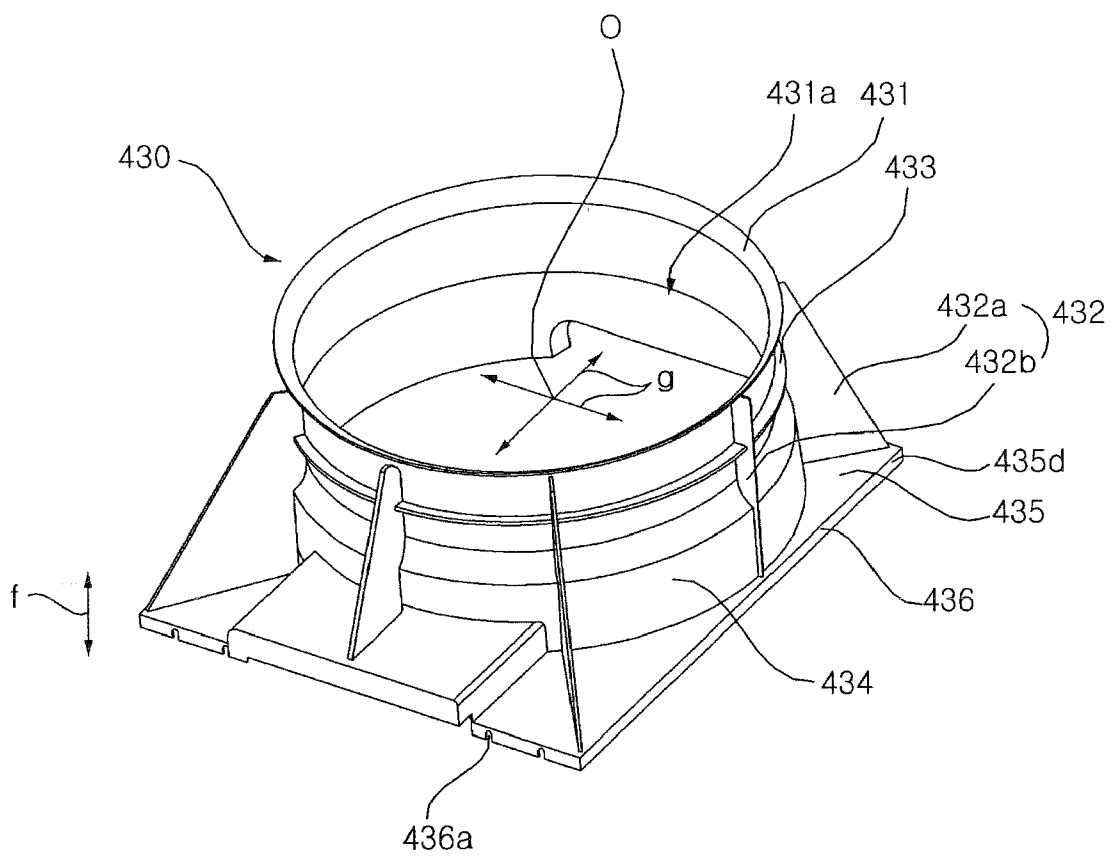

FIG. 10

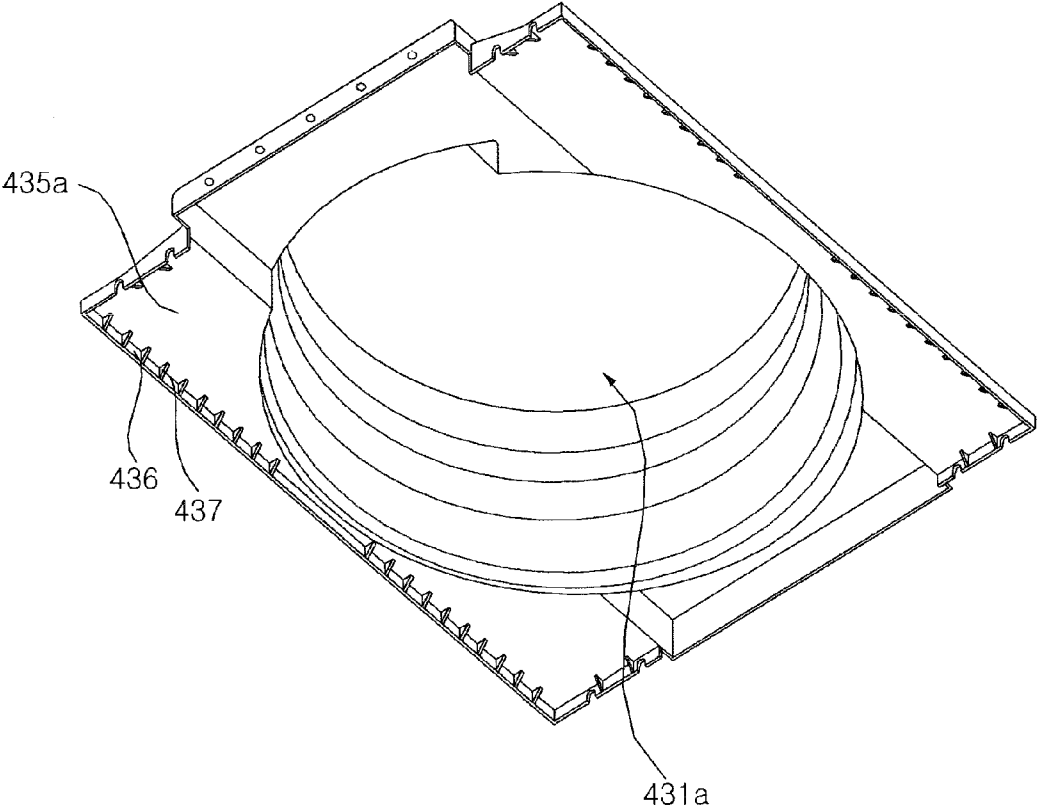
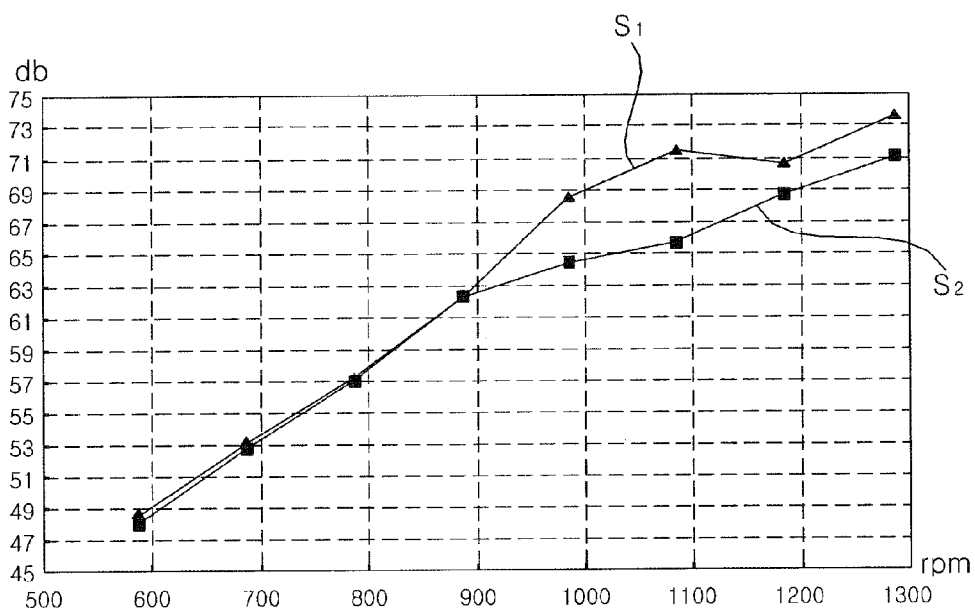

FIG. 11



AIR CONDITIONER

BACKGROUND

[0001] 1. Field

[0002] This relates to an air conditioner, and particularly to an air conditioner with a shroud having reduced vibration and noise levels.

[0003] 2. Background

[0004] Air conditioners are air conditioning devices that keep indoor air fresh so that a prescribed space is appropriate for humans to live in. An air conditioner absorbs or discharges heat in a prescribed space to keep moisture and temperature at a constant level in the space. In order to accomplish this, such an air conditioner may include an outdoor unit to discharge the heat it has absorbed from the space during operation to the outside, or to absorb heat from the outside.

[0005] For efficient heat exchange between the outdoor unit and the outside, the air in the outdoor unit is exchanged with outdoor air so that a prescribed difference in temperature may be maintained between the heat exchanger in the outdoor unit and the air in the outdoor unit. For this, the air in the outdoor unit may be discharged to the outside and subjected to circulation. This operation may be accomplished by a blower fan provided at the outdoor unit.

[0006] Rotation of the blower fan causes the flow of air. Such air flow is guided to the outside by a shroud. While the air flow is guided by the shroud, vibration or noise of the shroud occurs due to the air flow. Such vibration or noise becomes large, especially at a rear part of the fan blade(s), where the air flow is more violent. A rear part of a shroud is positioned above the rear part of the blade(s), and thus making it difficult to remove vibration or noise of the shroud as well as to effectively guide the air flow to the outside.

[0007] A difference in pressure, which occurs while the blower fan rotates, causes air to flow to the outside of the outdoor unit. Outer air enters into the outdoor unit to replace the discharged air, and this leads to circulation of air between inside and outside of the outdoor unit. In the middle of the air circulation, effective heat exchange is done in the outdoor unit. While the blower fan operates to create air flow, the air is affected by various members in the outdoor unit to increase the noise and vibration. And, the discharged air may become turbulent so that energy used for discharging the air produces a vortex that has nothing to do with air discharge, or causes inner circulation which lowers energy efficiency.

BRIEF DESCRIPTION OF THE DRAWINGS

[0008] The embodiments will be described in detail with reference to the following drawings in which like reference numerals refer to like elements wherein:

[0009] FIG. 1 is a perspective view of an outdoor unit including a blower fan assembly according to an embodiment as broadly described herein;

[0010] FIG. 2 is a cross sectional view taken along the line II-II shown in FIG. 1;

[0011] FIG. 3 is a schematic view of air flow in the outdoor unit shown in FIG. 1;

[0012] FIG. 4 is a perspective view of an exemplary shroud of the outdoor unit shown in FIG. 1;

[0013] FIG. 5 is a cross sectional view taken along the line V-V shown in FIG. 4;

[0014] FIG. 6 is a perspective view of another exemplary shroud of the outdoor unit shown in FIG. 1;

[0015] FIG. 7 is a cross sectional view taken along the line VII-VII shown in FIG. 6;

[0016] FIG. 8 is a cross sectional view of another exemplary shroud of the outdoor unit shown in FIG. 1;

[0017] FIGS. 9 and 10 illustrate other exemplary shrouds of the outdoor unit shown in FIG. 1; and

[0018] FIG. 11 is a graph illustrating the magnitude of noise generated per each rotation number of a blower fan, as experimental values showing effects of lowering in vibration of the outdoor unit for an air conditioner, which includes the shroud shown in FIG. 9.

DETAILED DESCRIPTION

[0019] A shroud may be arranged at a front side of a blower fan to smoothly guide air discharged by a difference in pressure created from rotation of the blower fan.

[0020] Such a shroud may have a different degree of effectiveness solving the vibration, noise, efficiency, and the like, problems discussed above depending on its shape. In particular, if the shape is incorrectly designed, resonance may occur between the shroud and the discharged air, which may increase vibration and noise, and lower energy efficiency. Accordingly, an effectively designed shroud becomes a critical factor for improvement in capacity of the outdoor unit.

[0021] FIG. 1 is a perspective view illustrating an outdoor unit 100 including a blower fan assembly 180, FIG. 2 is a cross sectional view taken along the line II-II shown in FIG. 1, and FIG. 3 is a view schematically illustrating air flow in the outdoor unit 100 shown in FIG. 1.

[0022] Referring to FIGS. 1 and 2, the outdoor unit 100 includes a cabinet 120, plural air inlets (not shown), heat exchangers 161 and 162, a compressor 171, a blower fan assembly 180, and a motor 150. The air inlet is arranged at the cabinet 120 so that outer air may enter into the outdoor unit 100. The heat exchangers 161 and 162 create heat exchange between the outdoor air entering through the air inlet and an inner coolant. The compressor 171 supplies the heat exchangers 161 and 162 with the inner coolant that performs heat exchange together with the outer air. The blower fan assembly 180 causes air flow by which the air, which has experienced heat exchange at the heat exchangers 161 and 162, is forcedly discharged to the outside. The motor 150 transfers a rotational force to a blower fan 140 included in the blower fan assembly 180.

[0023] The cabinet 120 includes a front plate 122 which functions as the front surface, a base 123 located at the bottom side of the front plate 122 to support various devices, a cabinet body 124 located at the upper side of the base 123 to be coupled with the front plate 122, and a top plate 121 at the top side of the cabinet body 124 to be coupled with the front plate 122. The cabinet body 124 includes a first air inlet (not shown) through which outer air is entered/exited, and a first grill 170 for removing unwanted materials included in the air that is entered/exited through the first air inlet. Further, the cabinet body 124 includes a second air inlet (not shown) through which outer air is entered/exited, and a second grill (not shown) for removing unwanted materials included in the air that is entered/exited through the second air inlet.

[0024] The blower fan assembly 180 includes a blower fan 140 that receives a rotational force from the motor 150 to make inner air flow to the outside, and a shroud 130 that guides the air flowing due to the blower fan 140 to the outside.

[0025] Referring to FIG. 3, as an indoor unit (not shown) of a multi air conditioner is activated, the outdoor unit 100 starts

a corresponding operation. When the outdoor unit **100** operates, a signal is applied to the motor **150** to activate the motor **150**. Upon receipt, the motor **150** rotates the blower fan **140** and this discharges inner air to the outside. When the air is discharged, outer air enters into the cabinet **120** through the first air inlet and the second air inlet. The entered air performs heat exchange along with the inner coolant at the first heat exchanger **161** and the second heat exchanger **162**. The inner coolant used for the heat exchange becomes a low-temperature, high-pressure coolant by the compressor **171**. The heat exchanged air flows in the cabinet **120**. The flowing air is discharged to the outside by the rotation of the blower fan **140** rotated by the motor **150**.

[0026] The motor **150** rotates at a high speed, and thus this leads to vibration and/or noise. A motor supporting structure **151** is arranged under the motor **150** to fix the motor **150**. Condensed water generated from the first heat exchanger **161** and the second heat exchanger **162** is drained in a side direction through a drain pan **163** that is elongated in the left and right direction.

[0027] FIG. **4** is a perspective view illustrating an exemplary shroud of the outdoor unit **100** shown in FIG. **1**, and FIG. **5** is a cross sectional view taken along the line V-V shown in FIG. **4**.

[0028] Referring to FIGS. **4** and **5**, the shroud **130** includes a first shroud **131** that guides the air flowing by the blower fan **140** to the outside and a second shroud **133** that is provided at a downstream end of the first shroud **131**, wherein the second shroud **133** has a substantially straight vertical outer wall with curved upper and lower ends at the coupling unit **132** and the connecting part **134** so that the air flow generated by the blower fan **140** may be stabilized. The shroud **130** is coupled with a discharge grill **110** for preventing external unwanted materials from contacting the blower fan **140**. When the blower fan **140** rotates, the air in the outdoor unit **100** is exited to the outside. The exited air is guided to the outside by the first shroud **131**. When the blower fan **140** rotates, air flow proximate the blade **141** becomes unstable. The unstable air collides with the shroud **130** and the cabinet body **124** thus to create vibration and noise. Since the second shroud **133** has a substantially straight vertical outer wall with curved upper and lower ends at the coupling unit **132** and the connecting part **134**, the unstable air may be stabilized. Accordingly, the unstable air is stabilized by the second shroud **133**, and this may reduce the noise or vibration created by the unstable air.

[0029] In the second shroud **133**, the outer peripheral surface of its transverse section may have various shapes. For example, the outer peripheral surface of the transverse section may be shaped as a circle. Or, the outer peripheral surface of the transverse section may be shaped as an ellipse. If the second shroud **133** is shaped as an ellipse or a circle, the unstable air collides with the second shroud **133** so that its flow is changed to have a uniform form. As a result, the unstable air is stabilized to reduce the noise and/or vibration.

[0030] Meanwhile, the rearmost part, or trailing edge, of the blade **141** may be arranged between the incoming and outgoing ends, or inlet and outlet, of the second shroud **133**. The air flowing through the shroud **130** collides with the rearmost part of the blade **141** to disturb the air flow. Consequently, the air flow becomes unstable at the trailing edge of the blade **141**. The unstable air flow may be stabilized by having the rearmost part of the blade **141** arranged between the front end and rear end of the second shroud **133**. That is, the unstable air flow created at the rearmost part of the blade

141 comes to collide with the second shroud **133** rapidly because the space between the second shroud **133** and the blade **141** is narrow. The air is discharged to the outside along with the air flowing through the blower fan **140**. Accordingly, the air flow may be stabilized without being unstable.

[0031] The shroud **130** may be formed so that the first shroud **131** may be integrated with the second shroud **133**, and further include a coupling unit **132** that couples the first shroud **131** with the second shroud **133** and a connecting part **134** that couples the shroud **130** with the cabinet **120**. The coupling unit **132** may be formed so that a portion thereof between the first shroud **131** and the second shroud **133** is curved. The air flow created by rotation of the blower fan **140** is discharged from the second shroud **133** through the first shroud **131** to the outside. The air stabilized in the second shroud **133** flows into the first shroud **131**, and at this time the air may be unstable unless the coupling unit **132** is curved. The coupling unit **132** forms a curved line with the first shroud **133** and the second shroud **133**. Since the coupling unit **132** is coupled with the first shroud **131** and the second shroud **133** to form a curved line, the air may be discharged to the outside with its flow stabilized. Such stabilized air flow may reduce energy utilized by the motor **150**. Also, the stabilized air flow may facilitate the air flow and effectively discharge the heat exchanged air to the outside of the outdoor unit **100**.

[0032] FIG. **6** is a perspective view illustrating another exemplary shroud of the outdoor unit **100** shown in FIG. **1**, and FIG. **7** is a cross sectional view taken along the line VI-VII shown in FIG. **6**. The same reference numerals as those shown the above mentioned exemplary embodiments refer to the same constitutional elements. Hereinafter, the descriptions will focus on differences from the above-described exemplary embodiments.

[0033] Referring to FIGS. **6** and **7**, a blower fan assembly **280** includes a guide member **235** that is extended from a second shroud **233** so as to couple the cabinet **120** with the second shroud **233**. The guide member **235** may be formed so that the connecting part **234** between the guide member **235** and the second shroud **233** is curved to be capable of guiding the air subjected to heat exchange in the heat exchangers **161** and **162** to the blower fan **140**.

[0034] The guide member **235** may be shaped as a tetragon to be coupled with the cabinet **120**. If the guide member **235** is shaped as a tetragon, each of its edges may be rounded to remove noise and vibration that may be created by air flow. The guide member **235** is shaped as a tetragon to be capable of being easily coupled with the cabinet **120**. The air flow created upon rotation of the blower fan **140** is discharged to the outside of the cabinet **120**. The air passes through the heat exchangers **161** and **162** and then flows into the guide member **235**. The air in the guide member **235** is guided to a first shroud **231** coupled to the second shroud **233** by a coupling unit **232**. Accordingly, the internal air flowing through the guide member **235** may be effectively guided to the shroud **130**.

[0035] FIG. **8** is a cross sectional view illustrating still another exemplary shroud of the outdoor unit **100** shown in FIG. **1**. The same reference numerals as those shown the above mentioned exemplary embodiments refer to the same constitutional elements. Hereinafter, the descriptions will focus on differences from the above-described exemplary embodiments.

[0036] Referring to FIG. 8, a blower fan assembly 380 may include a shroud 330 having a first shroud 331 and a second shroud 333 connected by a coupling unit 332, and a guide member 335 coupled to the second shroud 333 by a connecting part 334. The shroud 330 may further include an air storage member 336. The air storage member 336 is arranged at the second shroud 333 and surrounds the blade 141. And, the air storage member 336 is spaced from the second shroud 333 and the outer peripheral surface of its transverse section is substantially identical to that of the second shroud 333. The air storage member 336 is arranged to be spaced apart from the second shroud 333 so as to form an air storage part 337 therebetween. If the blower fan 140 rotates, air flow is created behind the blade 341. The air flow becomes unstable due to the air flow created near the rearmost part, or trailing edge, of the blade 341, and this vibrates the shroud 330 to cause noise.

[0037] Meanwhile, the unstable air flow is eliminated or stabilized thanks to the air storage member 336. Unstable air flow is trapped by the air storage part 337 as it flows beyond the air storage member 336. The unstable air flow may be stabilized by being trapped in the air storage part 337. Accordingly, it may be possible to effectively reduce or eliminate the vibration or noise created by the unstable air flow.

[0038] FIGS. 9 and 10, respectively, are views illustrating other exemplary shrouds of the outdoor unit 100 shown in FIG. 1.

[0039] Referring to FIG. 9, the shroud 430 includes a first shroud 431, a second shroud 434, a guide member 435, and reinforcement plates 432. The first shroud 431 has an outlet 431a which smoothly guides heat exchanged air from the heat exchangers 161 and 162 and is discharged to the outside of the outdoor unit 100 due to a difference in pressure between the front side and rear side, which is formed by the blower fan 140. The guide member 435 supports the first shroud 431 and is coupled with an inner surface of the cabinet 120 to support the first shroud 431 so that the shroud 430 is fixed to the inside the cabinet 120. The second shroud 434 is located between the guide member 435 and the first shroud 431 and traps the air vortex created due to discharge of the air by rotation of the blower fan 140 to lessen the vibration of the outdoor unit 100. The reinforcement plates 432 may reinforce the guide member 435 to reduce noise by supporting the first shroud 431 and the guide member 435 and lessening the upper and lower vibration (shown in the direction of the arrow f) of the guide member 435.

[0040] The amplitude of the upper and lower vibration (f) of the guide member 435 increases as it progresses to the end of the guide member 435, and thus the reinforcement plates 432 may support the end of the guide member 435 and the first shroud 431 to reduce the vibration. And, an outermost edge 435d of the guide member 435 is spaced furthest from the center of the shroud 430 as seen from the drawings, and thus the largest vibration is created near the edge 435d. Therefore, the reinforcement plates 432 may include a first reinforcement plate 432a that supports the outermost end 435d of the guide member 435 and the first shroud 431, and a second reinforcement plate 432b that supports a more narrow portion of the guide member 435. And, since it may be effective to form the reinforcement plate 432 together with the shroud 430 in terms of work efficiency, the reinforcement plate 432 may be arranged at the shroud 430 to support all of the guide member 435, the second shroud 434, and the first shroud 431.

[0041] As air is discharged through the first shroud 431 as the blower fan 140 rotates, the pressure of the discharged air

is varied periodically, and such variation in pressure leads to vibration (in the direction of arrow g) toward the center of the first shroud 431. Such vibration (g) becomes a source of noise and fatigue of the first shroud 431. In order to reduce this vibration, a reinforcement ring 433 is arranged at the first shroud 431 to surround the circumference of the first shroud 431 to reinforce the first shroud 431 and reduce the center-oriented vibration (g) of the first shroud 431.

[0042] As shown in FIG. 10, a bending part 436 may be provided at the end of the guide member 435 included in the outdoor unit 100 to reinforce the guide member 435 to reduce the vibration (f) of the guide member 435. The bending part 436 may be formed, for example, rearward, but the direction of forming the bending part 436 is not particularly so limited. And, a reinforcement rib 437 may be arranged at a rear surface 435a of the guide member 435 to connect the end of the bending part 436 with the rear surface 435a of the guide member 435 to reinforce the guide member 435 and lessen the vibration. In this embodiment, the reinforcement rib 437 is shown arranged at the rear surface 435a of the guide member 435 since the bending part is formed rearward. However, the reinforcement rib 437 may be also arranged at the front surface of the guide member 435. Meanwhile, at least one of the bending parts 436 is attached to the inside of the cabinet 120 by a connecting member such as bolts or pins that is connected through a coupling hole 436a provided at the bending part 436, and thus the shroud 430 is fixed to the cabinet 120. In terms of reduction of vibration, the guide member 435 may have the same cross section as that of the cabinet 120 and the overall surfaces of the bending part 436 are attached to the inside of the cabinet 120 so that the shroud 130 may be firmly fixed in the cabinet 120. In the meanwhile, since the cross section of the cabinet 120 is shaped as a rectangle as shown in the drawings, the guide member 435 may be shaped as a rectangle correspondingly.

[0043] FIG. 11 is a graph illustrating the magnitude of generated noise (in decibels dB) per each rotation number of a blower fan. In particular, FIG. 11 illustrates experimental values showing effects of the shroud shown in FIG. 9 in lowering vibration of the outdoor unit 100.

[0044] The graph S1 shows the magnitude of noise generated per rotation number of the blower fan in a shroud that does not include a reinforcement plate 432, reinforcement ring 433, the reinforcement rib 437 shown in the exemplary embodiments. The graph S2 shows the magnitude of noise generated per rotation number of the blower fan in a shroud that includes the reinforcement plate 432, the reinforcement ring 433, and the reinforcement rib 437 shown in the exemplary embodiments so that its strength has been reinforced. As shown in FIG. 11, the amount of noise generated is sharply lessened at relatively high-speed rotation of the blower fan by these reinforcement components.

[0045] An air conditioner is provided that may reduce noise generated in a blade of a blower fan due to air flow.

[0046] An air conditioner is provided that may lower vibration and noise as well as increase energy efficiency.

[0047] An air conditioner embodied and broadly described herein may include a blower fan that creates flow of air; a first shroud that guides the air flowed by the blower fan to the outside; and a second shroud provided behind the first shroud, the outer peripheral surface of a transverse section of the second shroud being formed to be curved so as to stabilize air flow created behind the blower fan.

[0048] The second shroud may stabilize air flow, and this may reduce vibration of the shroud that occurs due to air flow at the rear part of the blade. Also, this may solve noise problem caused by the vibration of the shroud.

[0049] An air conditioner as embodied and broadly described herein may provide smooth guiding of the flow of air discharged upon rotation of the blower fan to increase energy efficiency.

[0050] An air conditioner as embodied and broadly described herein may reinforce the intensity of the shroud without any increase in weight of the shroud to increase life span of the outdoor unit for the air conditioner.

[0051] An air conditioner as embodied and broadly described herein may minimize resonance between the air discharged by the blower fan and the shroud as well as the amplitude of vibration of the shroud itself to reduce the vibration and noise.

[0052] Any reference in this specification to “one embodiment,” “an embodiment,” “example embodiment,” etc., means that a particular feature, structure, or characteristic described in connection with the embodiment is included in at least one embodiment as broadly described herein. The appearances of such phrases in various places in the specification are not necessarily all referring to the same embodiment. Further, when a particular feature, structure, or characteristic is described in connection with any embodiment, it is submitted that it is within the purview of one skilled in the art to effect such feature, structure, or characteristic in connection with other ones of the embodiments.

[0053] Although embodiments have been described with reference to a number of illustrative embodiments thereof, it should be understood that numerous other modifications and embodiments can be devised by those skilled in the art that will fall within the spirit and scope of the principles of this disclosure. More particularly, numerous variations and modifications are possible in the component parts and/or arrangements of the subject combination arrangement within the scope of the disclosure, the drawings and the appended claims. In addition to variations and modifications in the component parts and/or arrangements, alternative uses will also be apparent to those skilled in the art.

What is claimed is:

1. An air conditioner, comprising:
 - a heat exchange unit configured to be coupled to an interior space to be heated or cooled, the heat exchange unit comprising:
 - a housing;
 - a fan that generates air flow through the housing;
 - a first shroud that guides the air flow generated by the fan to an outside of the housing; and
 - a second shroud coupled to a downstream end of the first shroud, wherein the second shroud has a substantially straight vertical outer wall with curved end so as to stabilize air flow generated by the fan.
2. The air conditioner of claim 1, wherein the outer periphery of the transverse section of the second shroud is substantially circular.
3. The air conditioner of claim 1, further comprising:
 - a coupling device that is integrally formed with the first shroud and the second shroud so as to couple the first shroud and the second shroud, wherein a portion of the coupling device near an area where the first shroud and the second shroud are joined to each other is curved.

4. The air conditioner of claim 1, further comprising:
 - a guide member that extends outward from the second shroud, wherein the guide member is configured to couple the housing and the second shroud, wherein a portion of the guide member in an area where the guide member and the second shroud are coupled to each other is curved.
5. The air conditioner of claim 4, further comprising:
 - a reinforcement device that supports the first shroud and the guide member.
6. The air conditioner of claim 5, wherein the reinforcement device also supports the second shroud.
7. The air conditioner of claim 5, further comprising:
 - at least one reinforcement rib that extends between a bending part provided at one end of the guide member to a rear surface of the guide member.
8. The air conditioner of claim 1, further comprising:
 - a reinforcement ring that surrounds an outer periphery of the first shroud.
9. An air conditioner, comprising:
 - a first unit configured to provide climate controlled air to a predetermined space; and
 - a second unit separate from and coupled to the first unit, wherein the second unit conducts a heat exchange operation with air outside of the predetermined space, the second unit comprising:
 - a housing;
 - at least one heat exchanger provided in the housing;
 - a fan that draws outside air into the housing and across the at least one heat exchanger, and that discharges heat exchanged air from the housing; and
 - a multi-staged shroud that is coupled to the housing, wherein the shroud surrounds the fan so as to direct the heat exchanged air out of the housing, wherein an interior contour of the multi-staged shroud is curved so as to correspond to an air flow pattern generated by the fan.
10. The air conditioner of claim 9, wherein the multi-staged shroud comprises:
 - a first shroud having a first end thereof that defines an outlet through which the heat exchanged air is discharged from the housing, and a second end opposite the first end thereof; and
 - a second shroud having a first end thereof coupled to the second end of the first shroud, and a second end opposite the first end thereof, wherein the second end of the second shroud defines an inlet into which heat exchanged air is introduced into the fan.
11. The air conditioner of claim 10, wherein the multi-staged shroud further comprises:
 - a curved first connecting portion that extends between the second end of the first shroud and the first end of the second shroud such that the interior contour of the multi-staged shroud is continuously curved.
12. The air conditioner of claim 11, wherein the interior contour of the multi-staged shroud is spaced apart from distal ends of a plurality of blades of the fan and curved so as to correspond to a rotation path of the distal ends of the plurality of blades so as to stabilize air flow generated by the fan.
13. The air conditioner of claim 11, wherein the multi-staged shroud further comprises:
 - a second connecting portion provided at the second end of the second shroud, wherein the second connecting portion couples the multi-staged shroud to an interior of the housing.

14. The air conditioner of claim **11**, wherein the multi-staged shroud further comprises:

a guide member coupled to the second end of the second shroud, wherein the guide member couples the multi-staged shroud to an interior of the housing; and
a reinforcement device that reinforces the first and second shrouds.

15. The air conditioner of claim **14**, wherein the reinforcement device comprises a reinforcement ring that extends around an outer periphery of either the first shroud or the second shroud.

16. The air conditioner of claim **14**, wherein the reinforcement device comprises:

at least one reinforcement plate that extends between the first and second shrouds and the guide member so as to reinforce the first and second shrouds; and

a plurality of reinforcement ribs that extend between an outer peripheral edge of the guide member and a rear surface of the guide member so as to reinforce the guide member.

17. The air conditioner of claim **11**, wherein the multi-staged shroud further comprises:

a storage member that extends downward from an area at which the second end of the first shroud and the first connecting portion are joined, wherein a gap is formed between the storage member and an interior surface of the second shroud, wherein unstable air generated by rotation of the fan is trapped within the gap so as to stabilize air flow through the multi-staged shroud.

* * * * *