

Nov. 18, 1924.

1,516,191

J. S. HOTCHKISS  
STAPLE DRIVING MACHINE  
Filed Aug. 17, 1922

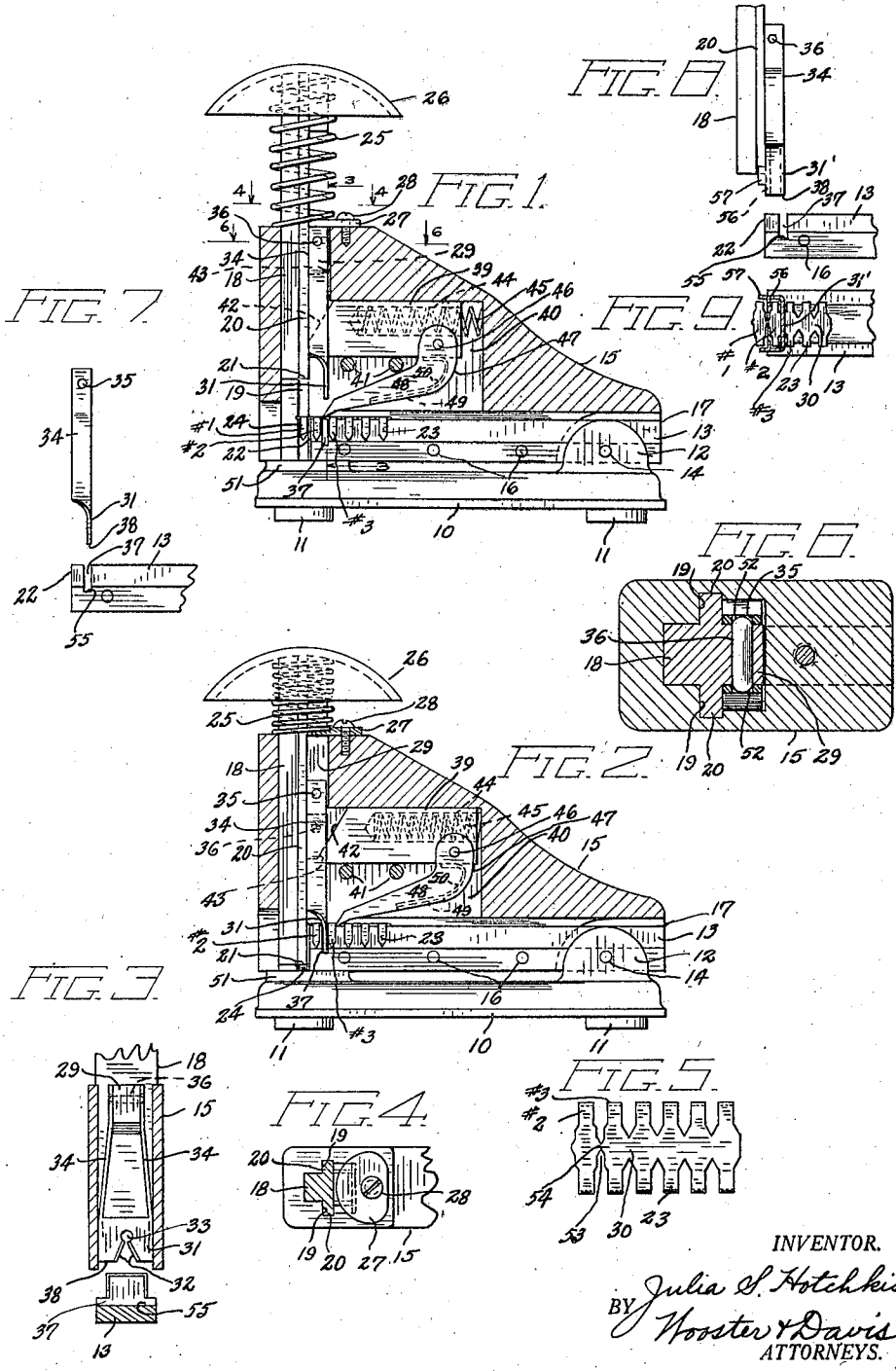

INVENTOR.

Julia S. Hotchkiss  
BY Hooster & Davis  
ATTORNEYS.

# UNITED STATES PATENT OFFICE.

JULIA S. HOTCHKISS, OF NORWALK, CONNECTICUT, ASSIGNOR TO THE E. H. HOTCHKISS COMPANY, OF NORWALK, CONNECTICUT, A CORPORATION OF CONNECTICUT.

## STAPLE-DRIVING MACHINE.

Application filed August 17, 1922. Serial No. 582,366.

*To all whom it may concern:*

Be it known that I, JULIA S. HOTCHKISS, a citizen of the United States, residing at Norwalk, county of Fairfield, State of Connecticut, have invented an Improvement in Staple-Driving Machines, of which the following is a specification.

This invention relates to stapling machines, and more particularly to that type known as strip stapling machines wherein each staple at the time it is driven is severed from a strip of integrally connected staples which is fed forwardly at each operation of the machine to bring the staples successively into a position to be severed and driven.

It is an object of the invention to provide a machine of this type which is simple in construction and which will be easier of operation than the ordinary machine.

It is also an object of the invention to provide improved means for severing the individual staples, which means will be easier of operation than that now generally employed.

It is a further object of the invention to provide means for partially severing the individual staples from the strip before they are fed into a position to be severed and driven.

It is a still further object of the invention to provide a machine of this type which may be easily and quickly assembled and disassembled when desired.

With these and other objects in view I have devised the construction illustrated in the accompanying drawing, in which—

Fig. 1 is a longitudinal sectional elevation through the casing of the machine showing the operating elements in elevation and in the position they occupy preparatory to severing and driving a staple.

Fig. 2 is a similar view showing the elements in the position they occupy immediately after the staple has been driven.

Fig. 3 is a transverse sectional view substantially on the line 3—3 of Fig. 1.

Fig. 4 is a partial transverse sectional plan view substantially on the line 4—4 of Fig. 1.

Fig. 5 is a plan view of a portion of a staple strip.

Fig. 6 is a transverse sectional plan view substantially on the line 6—6 of Fig. 1.

Fig. 7 is a detailed view showing certain elements removed from the machine.

Fig. 8 is a similar view of a slightly modified construction, and

Fig. 9 is a transverse sectional plan view of the construction shown in Fig. 8.

The machine comprises the usual base 10 provided with suitable supports such as rubber lugs 11, the base being provided with upward extending spaced ears 12 in which the substantially T-shaped staple strip carrying bar or slide 13 is pivoted by any suitable means such as a pin 14. This bar is secured within the lower part of the body or casing 15 by any suitable means such as the transverse pins 16, the staple strip being inserted in the machine and around this bar from the rear end 17 thereof in the usual manner.

The casing 15 is provided in the forward part thereof with upright guides in which is slidably mounted a plunger 18 preferably substantially T-shaped in cross section. The guiding means in the casing includes slots or grooves 19 on opposite sides of the plunger in which the oppositely extending ribs 20 of the plunger are adapted to slide. The lower end of the plunger has a sharp edge 21 adapted to coact with the sharp edge at the top of the forward end 22 of bar 13 to sever the individual staples from the staple strip 23 carried by the bar. The forward staple 24, hereinafter called staple No. 1 when the elements are in the severing and driving position shown in Fig. 1, is guided in the grooves 19 after it is severed from the strip. The plunger is normally held in its raised position by coil spring 25 abutting at its opposite ends on the casing 15 and the underside of the knob 26, the upward movement thereof being limited by means of a stop 27 secured to the top of the casing by any suitable means such as a screw 28 and adapted to extend over the shoulder provided at the end of the lug 29 carried by the plunger.

Rearwardly of the plunger and spaced a

proper distance therefrom so as to act upon the integral connecting means 30 between the adjacent staples and preferably between staples 2 and 3 is located my auxiliary cutting or partial severing means which, in the form shown in Figs. 1 to 7, comprises a substantially flat body element 31 having cutting means at its lower end, in the form shown preferably inclined cutting edges 32, which may be plane or saw toothed as desired, and terminate at their upper ends in a recess 33 of greater width than the shortest distance between the cutting edges. Secured to the sides of this element and extending upwardly therefrom on opposite sides of the lug 29 carried by the plunger are spring arms 34 adapted to yield outwardly away from the plunger under certain conditions but tending, due to their resiliency, to move toward each other. These arms are provided with aligned openings 35 adjacent their upper ends adapted to coact with the transverse pin 36 in the lug 29 to reciprocate this auxiliary cutting means with the plunger but under certain conditions to spring outwardly from the ends of the pin to allow the plunger to move independently of the auxiliary cutting means. The staple strip carrying bar or slide 13 is provided adjacent its forward end with a transverse recess or groove 37 of the proper depth to form a stop to engage the lower end 38 of the auxiliary cutter to limit the downward movement thereof upon operation of the plunger and to also coact with this auxiliary cutter to facilitate the operation of this cutter.

Suitable means is provided for feeding the staple strip forwardly which may be of any desired construction. That shown comprises a slidable block 39 mounted to reciprocate horizontally in a chamber 40 in the casing upon transversely extending pins 41 and provided with an inclined forward end 42 adapted to coact with the inclined surface 43 on the lug 29. This block has a longitudinally extending socket 44 on which is mounted a coil spring 45 pressing at its opposite ends on the rear wall of the chamber 40 and the bottom of socket, and thus tends to hold the block in its forward position. Pivoted to the block at a point 46 so as to move therewith is a lever 47 shaped at its forward end to engage between the individual staples to advance the strip on the slide or bar when the block 39 is allowed to move forward under the action of the spring 45, the bottom of this engaging means being inclined to allow it to slide over the staple strip without moving the same when the block is moved rearwardly. The lever 47 has two transversely spaced arms 48 having lugs which embrace the opposite sides of the block for

the pivot, these arms being connected by bridge 49 upon the top of which bridge a spring 50 acts and tends to hold the engaging means at the forward end of the lever in contact with the strip. It will be apparent the block is given reciprocating movement equal to the distance between two adjacent staples of the strip upon each operation of the plunger so that the individual staples are successively and automatically placed in the severing and driving position.

The operation is as follows:

Assuming the elements are in the position shown in Fig. 1, the operator strikes a blow on the knob 26 thus depressing the plunger which removes staple No. 1, which is in alignment with the lower end thereof, from the staple strip and forces the same through the articles to be connected and clinches the same by the reaction with the anvil 51 carried by the base. As the plunger moves downwardly and as the rounded ends 52 of the pin 36 are in the openings 35 of the spring arms 34, the auxiliary cutting means 31 is moved downwardly with the plunger and the cutting edges thereof engage on opposite sides of the integral connecting means 30 on the staple strip between the staples 2 and 3 and partially severs staple 2 from the strip, as shown at 53 in Fig. 5, leaving a very small connecting means 54 between the staples 2 and 3. This connection is merely strong enough to properly support the staple in position to be completely removed by the lower end of the plunger upon the next operation, the lower end of the plunger and the cutting edges 32 being preferably so positioned that they engage the strip at about the same time. After staple No. 2 has been partially severed the small holding means 54 passes into the recess 33 and the lower end 38 of the auxiliary cutting means engages the bottom 55 of the groove 37 in the bar 13 and prevents further downward movement of the auxiliary cutter. But, in order to clinch staple No. 1 which has been removed from the strip by the plunger, the plunger must have further downward movement. When the auxiliary cutting means has been stopped the spring arms 34 are pressed outwardly by the curved ends of the pin 36 to allow the plunger to continue this further movement. After the staple has been driven and pressure on the knob 26 removed the spring 25 raises the plunger to its uppermost position and the auxiliary cutting means will be raised with the same either by frictional engagement of the ends of pins 36 with the arms 34, or, if this is not sufficient, these ends will eventually engage the openings 35 and raise the auxiliary cutter. If it is raised by the friction engagement between these elements the upward movement of the auxiliary cutter will

be limited by the stop 27 and will hold it stationary until the ends of the pins 36 engage the openings 35.

It will thus be seen that the burden of cutting the individual staples from the strip is removed from the lower end of the plunger, and as staple No. 1 when in the severing and driving position is connected with the strip only by a very small connection which is easily broken, upon downward movement of the plunger there is practically no resistance at the lower end thereof and so the staple No. 1 is not likely to be bent out of position by the plunger and it will always be driven in the upright position preventing clogging of the machine. In the old form of severing means where the plunger performs the entire severing operation, as the lower end of the plunger is horizontal the entire connection 30 between the staples must be cut at one time, which renders the operation difficult and also if movement of the plunger is not a rapid one tends to twist the staple on the strip and incline the legs or prongs thereof rearwardly out of vertical position before it is completely severed, and so renders the machine liable to clogging and also may not properly set the staple.

With this device the burden of the cutting is placed on the separate auxiliary cutting element which cuts from both sides of the connection 30 and so the cutting operation may be a gradual one, and as the adjacent staples between which this element is operating are rigidly supported on the top of the bar on opposite sides of the groove 37, there is no tendency to bend them out of position during the cutting operation.

In the form shown in Figs. 8 and 9 the auxiliary cutting means 31' is provided with vertically extending ribs 56 adapted to extend between staples 1 and 2 to prevent turning of the staples. If desired the sides may also be extended as shown at 57 on opposite sides of staple No. 1 to prevent wobbling of the same in the guides 19.

If it is desired to remove the plunger and auxiliary cutter from the casing all that is necessary is to loosen screw 28 and turn the stop 27 from the path of movement of lug 29, the forward part of the stop being formed on the arc of a circle of which the screw is a center. When this stop is moved to one side the plunger and auxiliary cutter may be removed through the top of the casing.

Having thus described the nature of my invention, what I claim is:

1. In a strip staple machine, means for slidably supporting a strip of formed, integrally connected staples, means for detaching individual staples from the strip and clinching the same, feeding means for advancing the staple strip, and means oper-

able with the detaching and clinching means for partially severing the second staple from the strip. 65

2. In a strip staple machine, means for slidably supporting a strip of formed, integrally connected staples, means for severing and clinching individual staples, means for advancing the staple strip to place the end staples successively in the severing position, and means for partially severing the staples prior to their movement to the severing position. 70 75

3. In a strip staple machine, means for slidably supporting a strip of formed, integrally connected staples, a reciprocating plunger for severing and clinching individual staples, means for feeding forwardly the staple strip to bring the staples successively into severing position, and means operated by the plunger for partially severing the staples prior to their movement to the severing position. 80 85

4. In a strip staple machine having a reciprocating plunger for severing and driving individual staples, staple strip feeding means, and means driven by and having lost motion connection with the plunger for partially severing the second staple prior to its movement to the severing position. 90

5. In a strip staple machine having a reciprocating plunger for severing and driving individual staples, staple strip feeding means, and means movable parallel with said plunger and traveling throughout part of its movement therewith for partially severing the second staple prior to its movement to the severing position. 95 100

6. In a strip staple machine, means for slidably supporting a strip of formed, integrally connected staples, a reciprocating plunger for severing and driving individual staples, staple strip feeding means, vertically reciprocable cutting means adapted to be driven downwardly to partially sever a staple, and means to connect the cutting means with said plunger so that it is reciprocated thereby, said means adapted to yield after the cutting operation to allow further movement of the plunger independently of the cutting means. 110

7. In a strip staple machine, means for slidably supporting a strip of formed, integrally connected staples, a reciprocating plunger for severing and driving individual staples, staple strip feeding means, said staple strip supporting means comprising a bar or slide adapted at its forward end to coact with said plunger to detach the individual staples, cutting means movable downwardly from above the staple strip, said bar or slide being provided with a transverse recess to receive said cutting means and coact therewith to partially sever the staples prior to movement to the sever-

ing position, and means for operating the cutting means.

8. In a strip staple machine having a reciprocating plunger for severing and driving individual staples, staple strip feeding means, means driven by the plunger for partially severing the second staple prior to its movement to the severing position, and staple straightening and guiding means carried by said second mentioned means.

9. In a strip staple machine having a reciprocating plunger for severing and driving individual staples, staple strip feeding means, means driven by the plunger for partially severing the second staple prior to its movement to the severing position, and staple straightening means movable with said second mentioned means.

In testimony whereof I affix my signature.  
JULIA S. HOTCHKISS.