

Aug. 2, 1938.

F. A. PRICE

2,125,688

PORTABLE ROLLER BENDER

Filed April 26, 1937

Fig. 1.

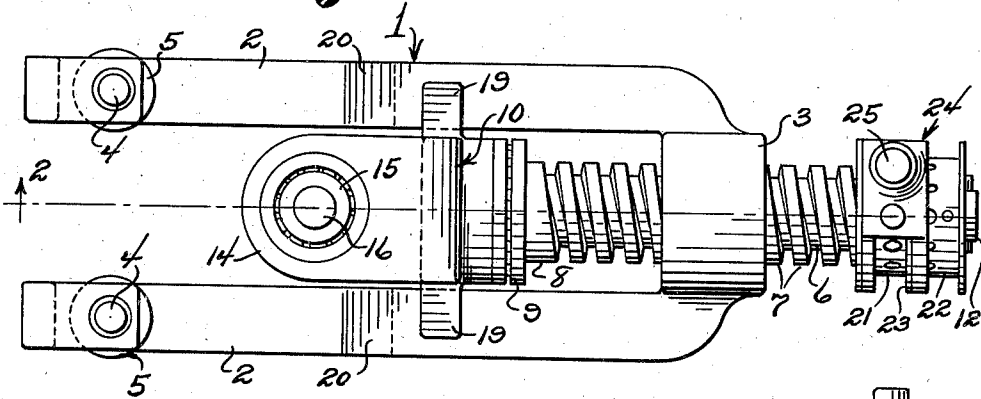

Fig. 2.

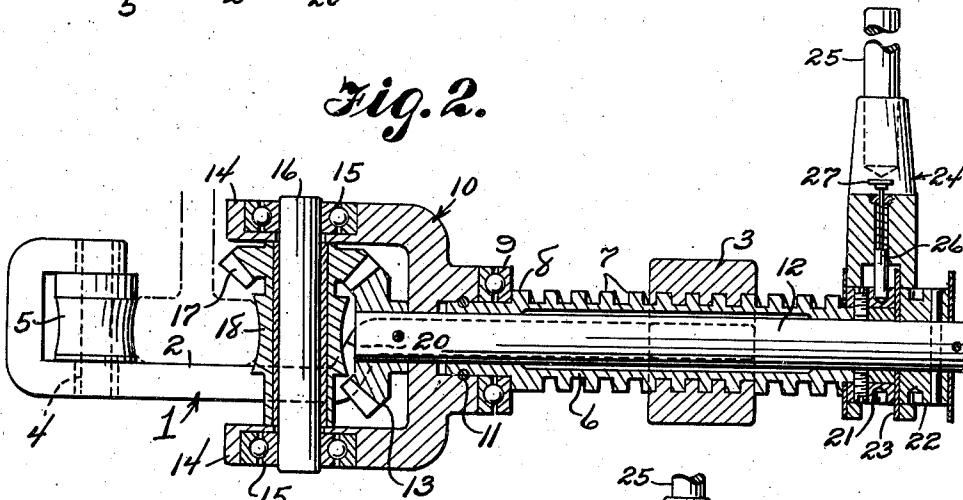

Fig. 3.

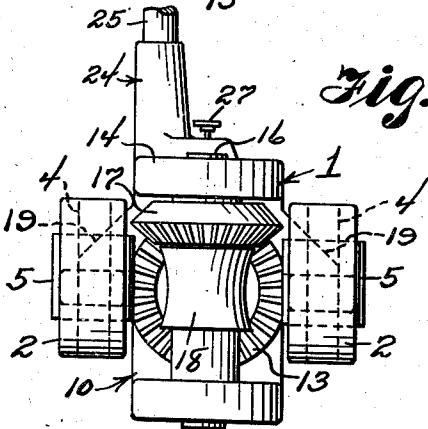
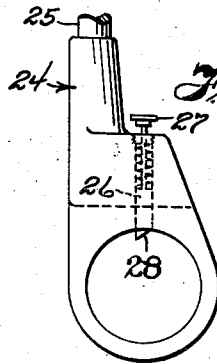

Fig. 4.



Fronso A. Price

INVENTOR

BY *Victor J. Cranswick*

ATTORNEYS

UNITED STATES PATENT OFFICE

2,125,688

PORTABLE ROLLER BENDER

Fronso A. Price, Ansted, W. Va.

Application April 26, 1937, Serial No. 139,051

4 Claims. (Cl. 153—38)

This invention relates to a portable metal bender especially adapted for bending railroad rails and has for the primary object the provision of an efficient, compact and durable device which will be simple, quick and easy to operate and may be readily adjusted for bending rails to curves of different radii.

With these and other objects in view, this invention consists in certain novel features of construction, combination and arrangement of parts to be hereinafter more fully described and claimed.

For a complete understanding of my invention, reference is to be had to the following description and accompanying drawing, in which

Figure 1 is a side elevation illustrating a portable rail bending device constructed in accordance with my invention.

Figure 2 is a sectional view taken on the line 2—2 of Figure 1.

Figure 3 is a fragmentary end elevation illustrating the device.

Figure 4 is a fragmentary side elevation illustrating an operating lever and the dog carried thereby.

Referring in detail to the drawing, the numeral 1 indicates a frame of substantially U-shape providing parallel spaced arms 2 and a connecting portion in the form of a feed box 3. The free ends of the arms 2 are bent upon themselves to form journals receiving axles 4 on which are journaled rollers 5. The peripheries of the rollers are concaved and said rollers engage one side of a rail, as shown in Figure 2, that is, the rollers 5 are brought in engagement with the tread or ball portion of the rail.

A feed sleeve 6 having feed threads 7 meshes with the feed box 3 and adjacent one end of said sleeve is an annular shoulder 8 abutted by a thrust bearing 9. The thrust bearing is mounted on said sleeve and also mounted on the sleeve is a head 10. The head 10 is free to rotate on the sleeve and is held against endwise movement by a fastener 11 and also abuts the thrust bearing 9. The head 10 is provided with a bore aligning with the sleeve 6 and through which extends a shaft 12. The shaft also extends through the feed sleeve 6 and has secured to one end a beveled gear 13. The head 10 includes parallel arms 14 having mounted therein anti-friction bearings 15 for rotatably supporting a stub shaft 16. Secured on the stub shaft is a beveled gear 17 which meshes with the gear 13. A roller 18 is secured on the shaft 16 and is adapted to engage the opposite side face of

the tread of the rail from the side face engaged by the rollers 5. The periphery of the roller 18 is concaved. Guide elements 19 are formed on the head 10 and contact with the arms 2, the latter being offset, as shown at 20, to position the rollers 5 in a plane with the roller 18.

A ratchet gear 21 is secured on the feed sleeve and a ratchet gear 22 is secured on the shaft 12. The ratchet gears 21 and 22 are closely related and separated from one another by a disc or washer 23.

A handle head 24 includes bifurcated apertured portions mounted on the ratchet gears 21 and 22 and are free to turn thereon. The handle head also includes a socket to receive the handle 25. A spring pressed dog 26 is carried by the head to engage either of the ratchet gears and may have its position reversed so as to operate either of the ratchet gears in either direction by an oscillatory movement of the handle 25. The dog 26 has a finger piece 27 for disengaging the dog from either of the ratchet gears and for reversing the position of the dog. The dog has a beveled end 28 to engage the ratchet gears. The dog 26 when in a retracted position by a pull on the handle 27 will clear the washer 23 and thereby permit the lever to be slid endwise of the shaft 12 so that the dog can be brought into engagement with either of the ratchet gears. The lever besides being journaled on the ratchet gears may also be slid as described for positioning the dog to engage with the selected ratchet when manually released.

In operation, the device is applied to a rail, as shown in Figure 2, and the roller 18 is adjusted for the proper curvature desired to be made in the rail by rotating the sleeve 6 through the oscillatory movement of the handle 25. After the proper adjustment of the roller 18 the head 24 is adjusted on the ratchet gears to bring the dogs into engagement with the ratchet gear 21 so that the shaft 12 may be rotated and thereby rotate the roller 18, causing the device to feed along the rail and at the same time bend the rail.

What is claimed is:

1. A rail bending device comprising a frame, rollers carried by said frame to engage one side of a rail, a feed box carried by said frame, a feed sleeve threaded in said feed box, a shaft journaled in said sleeve, a head journaled on said feed sleeve, a roller journaled on said head to engage the opposite side of the rail from the first-named rollers, a drive means connecting the shaft to said second-named roller, and means whereby

either the sleeve or the shaft may be rotated and in either direction.

2. A rail bending device comprising a frame, rollers carried by said frame to engage one side of a rail, a feed box carried by said frame, a feed sleeve threaded in said feed box, a shaft journaled in said sleeve, a head journaled on said feed sleeve, a roller journaled on said head to engage the opposite side of the rail from the first-named rollers, a drive means connecting the shaft to said second-named roller, a ratchet gear secured on said sleeve, a second ratchet gear secured on the shaft and closely related to the first ratchet gear, a handle head journaled on said ratchet gears, and adjustable relative thereto, a dog carried by said handle head and engageable with either of said ratchet gears and reversible to permit operation of the ratchet gears in either direction, and a handle secured to said handle head.

3. A rail bending device comprising a frame including spaced arms and a connecting portion for said arms in the form of a feed box, a feed sleeve journaled in said box, a shaft journaled in said feed sleeve, a head journaled on said sleeve, a thrust bearing between said head and sleeve, said head including arms, anti-friction bearings carried by the last-named arms, a shaft

supported by said anti-friction bearings, gearing connecting said shafts, a roller secured to the second shaft, rollers journaled on the first-named arms and the latter being offset to position said second-named rollers in a plane with the first-named roller, said rollers having concaved peripheries, and means for rotating the sleeve and the shaft independently of each other and in either direction.

4. A rail bending device comprising a frame including spaced arms and a connecting portion for said arms in the form of a feed box, a feed sleeve journaled in said box, a shaft journaled in said sleeve, a head journaled on said sleeve, a thrust bearing between said head and sleeve, said head including arms, anti-friction bearings carried by the last-named arms, a shaft supported by said anti-friction bearings, gearing connecting said shafts, a roller secured to the second shaft, rollers journaled on the first-named arms and the latter being offset to position said second-named rollers in a plane with the first-named roller, said rollers having concaved peripheries, means for rotating the sleeve and the shaft independently of each other and in either direction, and guide elements formed on the arms of said head and engaging the arms of said frame.

FRONSO A. PRICE.