



INTERNATIONAL APPLICATION PUBLISHED UNDER THE PATENT COOPERATION TREATY (PCT)

<p>(51) International Patent Classification <sup>6</sup> : <b>G06F 17/30, 13/00, H04L 12/54</b></p>	<p><b>A1</b></p>	<p>(11) International Publication Number: <b>WO 96/38795</b> (43) International Publication Date: 5 December 1996 (05.12.96)</p>
<p>(21) International Application Number: PCT/US96/08017 (22) International Filing Date: 30 May 1996 (30.05.96) (30) Priority Data: 08/453,486 30 May 1995 (30.05.95) US (71) Applicant: CORPORATION FOR NATIONAL RESEARCH INITIATIVES [US/US]; Suite 100, 1895 Preston White Drive, Reston, VA 22091-5434 (US). (72) Inventors: KAHN, Robert, E.; 909 Lynton Place, McLean, VA 22102 (US). CERF, Vinton, G.; 3614 Camelot Drive, Annandale, VA 22003 (US). ELY, David, K.; 3015 Miller Heights Road, Oakton, VA 22124 (US). (74) Agent: FEIGENBAUM, David, L.; Fish &amp; Richardson P.C., 225 Franklin Street, Boston, MA 02110 (US).</p>		<p>(81) Designated States: AU, CA, CN, JP, MX, European patent (AT, BE, CH, DE, DK, ES, FI, FR, GB, GR, IE, IT, LU, MC, NL, PT, SE).  <b>Published</b> <i>With international search report.</i></p>

(54) Title: SYSTEM FOR DISTRIBUTED TASK EXECUTION

(57) Abstract

Tasks can be done on a network of multiple Knowbot Service Station computers (56a, 56b). At each of the computers (56a, 56b), Knowbot Programs (54a, 54b) may be received and transmitted on the communication links, and may be stored and created in the Knowbot Service Environment (50). Each Knowbot Program (54a, 54b) includes a globally unique identifier, navigation information defining a route through the network; and information concerning a task to be done. Knowbot Programs (54a, 54b) may interact with each other and other network resources through observing Knowbot Emissary rules and possibly purchase or contract for goods and services by means of Knowbot charge currency. Self-authenticating Knowbot Service Stations (56a, 56b, ...), in the Knowbot Framework (28), create and authenticate Knowbot Programs (54a, 54b), protect data as well as control its application in the network environment according to stated terms and conditions.

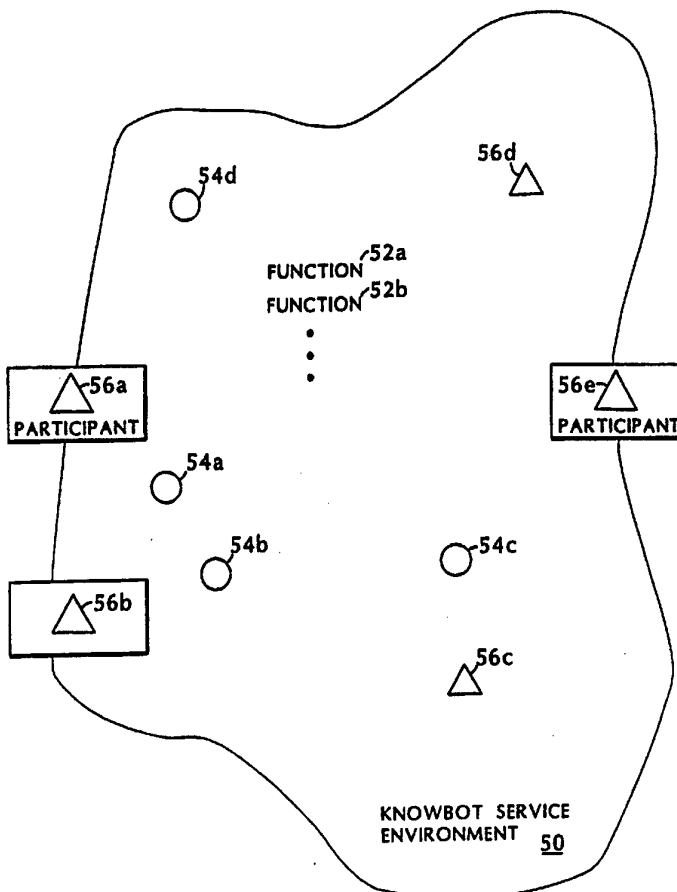

**FOR THE PURPOSES OF INFORMATION ONLY**

Codes used to identify States party to the PCT on the front pages of pamphlets publishing international applications under the PCT.

AM	Armenia	GB	United Kingdom	MW	Malawi
AT	Austria	GE	Georgia	MX	Mexico
AU	Australia	GN	Guinea	NE	Niger
BB	Barbados	GR	Greece	NL	Netherlands
BE	Belgium	HU	Hungary	NO	Norway
BF	Burkina Faso	IE	Ireland	NZ	New Zealand
BG	Bulgaria	IT	Italy	PL	Poland
BJ	Benin	JP	Japan	PT	Portugal
BR	Brazil	KE	Kenya	RO	Romania
BY	Belarus	KG	Kyrgyzstan	RU	Russian Federation
CA	Canada	KP	Democratic People's Republic of Korea	SD	Sudan
CF	Central African Republic	KR	Republic of Korea	SE	Sweden
CG	Congo	KZ	Kazakhstan	SG	Singapore
CH	Switzerland	LI	Liechtenstein	SI	Slovenia
CI	Côte d'Ivoire	LK	Sri Lanka	SK	Slovakia
CM	Cameroon	LR	Liberia	SN	Senegal
CN	China	LT	Lithuania	SZ	Swaziland
CS	Czechoslovakia	LU	Luxembourg	TD	Chad
CZ	Czech Republic	LV	Latvia	TG	Togo
DE	Germany	MC	Monaco	TJ	Tajikistan
DK	Denmark	MD	Republic of Moldova	TT	Trinidad and Tobago
EE	Estonia	MG	Madagascar	UA	Ukraine
ES	Spain	ML	Mali	UG	Uganda
FI	Finland	MN	Mongolia	US	United States of America
FR	France	MR	Mauritania	UZ	Uzbekistan
GA	Gabon			VN	Viet Nam

- 1 -

## SYSTEM FOR DISTRIBUTED TASK EXECUTION

This invention relates to distributed task execution.

5 Glossary of Terms

Below, for convenience, we set forth a short glossary of terms which supplement explanations of certain terms used in the main text.

"Network" is set of computers and a communication  
10 medium which interconnects them.

"Network participant" is an entity that may require a task to be done and has access to a distributed network.

"Packet" is an elemental container for carrying  
15 data in a distributed system; it typically includes addressing information used in routing.

"Protocol" is a set of commonly agreed rules which define the structure, format, procedure and/or function that must be followed for elements of a distributed  
20 system to communicate with each other.

"Resource" is information or a service accessible at a location in a distributed system.

"Task" is something capable of being done using one or more resources.

25 "Digital object" generally means sequences of digits (containing digital representations of virtually any kind of information) including an associated unique identifier, called its "handle."

"Repository" is a resource that stores digital  
30 objects and makes them accessible over the network according to applicable terms and conditions.

"Database" is an organized body of information structured so as to analyze queries and furnish replies. A digital object may itself contain a database or

- 2 -

elements of a database.

"Rights holder" is a person or entity which has legally enforceable "rights" in a digital object.

"Distributed system" may include a Knowbot system, 5 as well as components which are outside the Knowbot system, such as magnetic diskettes, optical disks, and other large scale storage media, including digital representations of data on paper.

"Knowbot program" is an executable computer 10 program, which may be capable of moving from one location to another. It includes an "instruction sequence" which defines a series of steps to perform a task and also includes other data.

"Courier" is used, on occasion, to refer to an 15 instance of a Knowbot program which is engaged in moving through a distributed system.

"Knowbot system" is a system (including programs) for creating, storing, and moving Knowbot programs among computers, executing the programs, and moving to and 20 storing the results as needed at destination computers or the Network.

"Knowbot service station" is software and/or hardware operating at a location on a network and capable of actions such as generating, storing, executing and 25 deleting Knowbot programs.

"Knowbot service environment" is a medium for handling Knowbot programs and comprises a collection of Knowbot service stations. The Knowbot system provides the service environment.

30 "Knowbot framework" is a conceptual model which defines a currency (Knowbot programs) for task execution and a medium (Knowbot service environment) for handling the programs.

"Notification authority" is a part of the Knowbot 35 service environment which stores information about

- 3 -

operations performed by Knowbot programs.

"Prospective Knowbot programs" are Knowbot programs received by a Knowbot service station from a source outside the Knowbot service environment.

## 5 Introduction

In the most basic sense, the invention concerns itself with a system (we call it the Knowbot® system) for creating, storing and moving programs among computers, executing the programs and moving to and storing the  
10 results as needed at destination computers. While most or all of the computers may be "online" and part of a general computer networking environment, the concepts apply also to offline movement of programs via other media such as magnetic diskettes, optical disks, and  
15 other large scale storage media, including digital representations of data on paper (such as bar coding). Moreover, the computers in the system need not be simultaneously connected in an underlying network at all times; this connectivity may come and go from time to  
20 time. The label "system" generally implies some systematic regularity in the way these programs are created and managed, the way they interact with each other, the way they interact with stored information, and the way they interact with external systems, including  
25 people and programs which are considered to exist outside the scope of the definition of the programs and computers which are part of the system.

For purposes of explanation, we sometimes use the term "Knowbot® system" (Knowbot® is a registered  
30 trademark of the Corporation for National Research Initiatives) to refer to portions or all of the system. The Knowbot® system has well-defined boundaries which make it possible to distinguish the components that are part of the system from components which are outside of  
35 it and which interact with it only in ways defined by the

- 4 -

system. What is inside the Knowbot system and what is outside may together be called a distributed system. The parts which are considered inside the system interact with other parts only in prescribed ways. The rules  
5 which define proper behavior are, in effect, specifications which determine how a component can be created and can operate so as to always be considered a properly functioning component of the system.

The Knowbot® system is largely a software system  
10 whose components are programs which operate in prescribed ways. Software operates in a computer-based (hardware) environment and often in association with software-based operating systems which are the basic programs that create, allocate and manage resources on the hardware.  
15 Underlying the basic design of the Knowbot® system is the assumption that the computers on which the system is operated have operating systems which provide functions needed by the Knowbot® system running "on top of" the operating systems. Any operating system would be  
20 suitable if it supports the embedding of the underlying computers in a data communications (networking) environment and is capable of "time-sharing" multiple programs running concurrently under the overall control of the operating system. In addition, the programs  
25 (called Knowbot programs) which are capable of moving between computers must contain sufficient information to allow them to begin or resume execution as intended and the computers must provide the necessary support environment such as interpreters, schedulers, and  
30 storage. The Knowbot® system may be implemented atop a wide variety of hardware and operating systems.

It is also assumed that the computers that are part of the Knowbot® system are at least intermittently connected to a common communication network so that  
35 information can pass from one computer to another from

- 5 -

time to time, in accordance with the rules of behavior of the Knowbot® system.

The Knowbot® system links together into a common operating environment many diverse and distinct systems and resources and serves as an interconnection system between them. Information about one system or its resources may be communicated to another system via the intermediary mechanism, the Knowbot® system. The Knowbot® system may itself enable tasks to be carried out distinct from the systems and resources which participate. The Knowbot® system may also facilitate these participating systems and resources to carry out a given task.

Below we discuss concepts which, when taken together, describe how a collection of software, hardware, and communication facilities can be organized to function as a Knowbot® system. Virtually all of the concepts are based on software artifacts behaving in accordance with a set of prescribed rules. These artifacts include "running programs" and also "digital objects" that are stored away in "repositories" for later access. The concepts of the invention generally are rooted in the definition and behavior of software artifacts rather than on the specifics of any particular hardware, communication network, or operating system. However, if desired, portions or all of the software could be replaced in certain instances with a system of integrated circuits (e.g., semiconductor chips) if and when the technology of very large scale integration permits.

Knowbot® programs are the basic software elements that execute in a given machine. An instance of a Knowbot® program is a Courier, the form taken by a Knowbot® program as it moves from one computer to another within the system or when it interfaces with the external

- 6 -

world. Knowbot® programs can contain (carry) information (data) which can be made manifest in a variety of ways. Provision is made in the Knowbot® system for dealing with the arrival and departure of Knowbot® programs, for the  
5 exchange of information between Knowbot® programs and other Knowbot® programs, and for the interaction of Knowbot® programs with other parts of the Knowbot® system including information access subsystems called "repositories" and with external subsystems, including  
10 people, by means of visible, audible, or other palpable manifestations.

An important characteristic of Knowbot® programs is their ability to protect data on behalf of rights holders, to control its application in accordance with  
15 stated terms and conditions and to interpret data, rendering it in multiple ways to be visible, audible or otherwise palpable and in such a way as to permit human interactions to influence the choice of renderings.

Because the Knowbot® system has a software based  
20 open-architecture interconnection structure, it is useful to discuss, another highly successful software-based open-architecture interconnection system known as the Internet. The Internet is a rapidly growing, global "network of networks" which links millions of computers  
25 and tens of thousands of networks together. The Internet is realized through a set of minimum requirements for linking computers to each other by way of a "packet switching" environment and through observing certain format and procedural conventions ("protocols") that  
30 govern how and when and in what form information is exchanged among the computers which are part of the Internet.

As seen in Fig. 1, the Internet 10 provides a communication framework 12 for computer users located  
35 essentially anywhere in the world. Any computer 14a may



- 7 -

send digital information to any other user 14b by observing a commonly understood packet protocol 16 and a commonly accepted addressing scheme 18. The packet protocol sets minimum rules for the structure and

5 handling of packets which carry the digital information, including the address of the recipient. The addressing scheme sets minimal rules for addressing assignments including prevention of duplicate addresses. A computer that follows the packet protocol and the addressing

10 scheme may be relatively confident that a packet will reach its destination and that the recipient will be able to access the digital information carried in it. On the other hand, the Internet framework makes essentially no attempt to define the physical hardware/software network

15 components 20 that are used to format, transmit, receive, disassemble or assemble packets, and instead leaves those matters to users, groups of users, and vendors. This has resulted in an open, distributed market for implementation schemes and products.

20 Because the hardware/software requirements of the packet protocol are minimal, and essentially any digital information may be carried in them, they provide a "currency" 22 for exchange of digital information across a distributed network, just as paper checks provide a

25 legal tender for exchange of economic value. The unambiguous addressing scheme and other aspects of the Internet framework in turn provide a universal medium 24 for exchange of packets, just as the unambiguous transit codes of the Federal Reserve clearinghouse provide a

30 universal medium for exchange of checks. But the Internet framework places no limits on the physical manner in which users may create, transmit, receive, and use packets, just as the clearinghouse system places no restrictions (provided paper size and other check

35 protocol requirements are met) on how checks are created,

- 8 -

delivered, received, or used.

The notion of disconnecting the medium and currency for exchange of digital information on a widely distributed network (i.e., the framework) from the physical implementation (suggested by the somewhat disjointed representations 12 and 20 on figure 1) is a powerful one and has led to the great success of the Internet, for it permits individuals and non-commercial and commercial enterprises to participate and benefit from the Internet without requiring central control of the implementation. At the same time the Internet community is constantly working to enhance and improve the principles embodied in the commonly accepted Internet framework. This is achieved through a decentralized process in which concepts may be generated from any source, tested, and if found broadly useful, ultimately become part of the accepted framework. In this context it is largely the quality of the proposed principles that generally governs whether they become part of the framework and are widely adopted.

Another powerful feature of the Internet framework and the physical network on which it is implemented is its ability to coexist easily with other frameworks of communication and other physical networks. The Internet currently accommodates many different types of networks and communications media; in principle almost any network or communications media can become part of the Internet.

Finally, the Internet framework is highly scalable which has yielded a relatively easy expansion of the number of users worldwide.

#### Detailed Description

As seen in Figure 2, in the invention, a new and more powerful framework (called a Knowbot framework 28) is created not merely for communicating digital information (as in the case of the Internet framework),

- 9 -

but for having tasks done on behalf of network participants 30a, 30b using resources available on a distributed system 32 (e.g., the Internet, or another network). Within the phrase "network participants" we  
5 include any entity that may require a task to be done, including individuals with standalone personal computers and organizations, as well as computers and other hardware and software in the network. By "task" we mean anything that is capable of being done by resources on  
10 the network; tasks may have a wide range of complexity, and typically they involve more than merely a communication of digital information of the kind effected by delivery of a simple Internet packet containing the digital information; in particular, tasks often involve a  
15 process step to be taken at a location that is remote from the location of the entity that requires the task to be done. By "resources" we mean whatever is available on the network that can contribute to the doing of a task; this could include computer software, stored digital  
20 objects and a wide variety of services.

The Knowbot framework defines both a "currency" for having tasks of any arbitrary complexity done, and a "medium" for handling the currency as part of getting the tasks done. The currency is called Knowbot programs. A  
25 Knowbot program is a mobile emissary of a network participant which assists in executing a task to be done on behalf of the participant. This task may be carried out locally in the user's system or it may involve interactions with other systems and resources at other  
30 locations both local and/or remote. The medium for handling Knowbot programs is called a distributed Knowbot service environment or simply the Knowbot service environment. The Knowbot service environment is distributed as a potentially endless number and variety  
35 of what we call Knowbot service stations (software and/or

- 10 -

hardware) operating at places on the network. The stations may generate, store, execute and delete Knowbot programs and otherwise perform all allowed operations on Knowbot programs as determined by the Knowbot program  
5 itself or by users authorized to take or enable such actions. The Knowbot framework defines a minimal set of rules 38 for the structure of Knowbot programs (for example, the program must include some information related to the task to be done) and a minimal set of  
10 rules 40 for the functions to be performed within the Knowbot service environment (for example, that a typical Knowbot service station be able to create, send, receive, monitor, and delete Knowbot programs).

Although we describe below some additional  
15 specific principles for Knowbot programs and the service environment, in general it is contemplated that enhancements to the Knowbot framework will be developed in a similar manner as for the Internet framework, that is by a combination of free market forces with respect to  
20 hardware and software implementations, and by an open standards development process within the Knowbot user community with respect to framework principles. Like the Internet framework, the Knowbot framework is meant to coexist freely with other techniques for doing tasks  
25 within a network and to be easily expandable.

In general, in one aspect, the invention features enabling tasks to be done on a network of multiple computers interconnected by communication links. Some or all of these computers may also be internal to the  
30 network. We use the term Courier, on occasion, to refer to a Knowbot program that is being sent from one service station to another, or is being exported (in some fashion) from the environment. At each of the computers, Knowbot programs may be received and transmitted on the  
35 communication links, and may be stored and created; and

- 11 -

execution of the tasks associated with the Knowbot programs may be advanced. Each Knowbot program includes a globally unique identifier; navigation information that may define a route through the network (when applicable);  
5 and information concerning the task to be done. Knowbot programs which are clones of each other will use the same basic identifier with a version number or some other delimiter to distinguish among them.

In general, in another aspect, the invention  
10 features enabling a computer on a network of multiple computers interconnected by communication links to participate in a distributed Knowbot service environment by the steps recited above.

Implementations of the invention may include one  
15 or more of the following features.

A participant at a computer (e.g., a person or a process or a Knowbot program running on the computer) may define the task to be executed. Information related to the defined task may be embedded in one of the Knowbot  
20 programs. Task information contained in Knowbot programs may be interpreted. The step of advancing the execution of tasks may include: creating additional Knowbot programs, interacting with other Knowbot programs, interacting with repositories of digital objects;  
25 querying a database of information; applying stored expert knowledge; protocol transformation; providing a directory service identifying other locations which provide services related to the task; making a security determination; providing a "what's new" service to  
30 identify newly available information; providing a "clipping" service which extracts information; providing a version control service for managing versions of the Knowbot program; responding to actions of a user by obtaining execution of the task at another location  
35 without necessarily indicating to the user that the

- 12 -

execution occurred at the other location; providing a method for determining the structure of a Knowbot program (e.g., to determine if a digital object is contained in the Knowbot program and to access the element; creating a  
5 derivative work from an existing work; generating a Knowbot program that contains another Knowbot program, or a digital object, or other data; and passing a message from a source Knowbot program to a target Knowbot program at a different location.

10           The information concerning a task to be done may include interpretable or executable instructions. The Knowbot program may include data in the form of a digital object or a Knowbot program (a Knowbot program may itself be a digital object). The digital object may include  
15 protocol transformation information.

          In general, in another aspect, the invention features executing a local query of a remote database (or a remote knowledge-based system) via a communication channel of a network where the local query complies with  
20 a query protocol and the remote database is responsive to queries which comply with a database protocol. A Knowbot program is locally generated based on the local query and in compliance with a Knowbot program protocol. The Knowbot program is sent to the remote database via the  
25 communication channel of the network. At the remote database, the Knowbot program is serviced by querying the database in accordance with the database protocol. The results of the query are returned from the remote database within a return Knowbot program which complies  
30 with the Knowbot program protocol.

          Implementations of the invention may include one or more of the following features. The return Knowbot program may be received locally and results may be provided to a user based on the results contained within  
35 the return Knowbot program. Additional Knowbot programs

- 13 -

may be generated which are based on the local query and  
comply with the Knowbot program protocol. Each of the  
additional Knowbot programs may work in parallel on a  
given database or repository or may be sent to another  
5 database. At each of the other databases, the  
corresponding Knowbot programs may be serviced by  
querying the other database. The results of the query  
from each of the other databases may be returned within a  
return Knowbot program which complies with the Knowbot  
10 program protocol. The results contained within the  
return Knowbot programs may be processed locally to  
provide a consistent presentation to a user. The  
consistent presentation to the user may be updated as  
additional return Knowbot programs are received. The  
15 processing may include removing redundant information.  
The return Knowbot program may be a modified version of  
the original Knowbot program. Additional Knowbot programs  
may be generated locally and sent via communication  
channels of the network. Knowbot programs may be  
20 generated as well as received locally.

The query protocol may include a displayable or  
machine interpretable form, obtained from another program  
or completed by a user. The Knowbot program protocol may  
differ from the query protocol and from the database  
25 protocol. The Knowbot program protocol may include the  
identity and syntax of an executable programming  
language. The Knowbot program may include an executable  
programming language entry and a navigational entry. The  
Knowbot program may reach the remote database site by  
30 navigating the network, and the navigational portion of  
the message may include information related to the  
navigating. The remote database site may send a status  
Knowbot program indicating the status of execution of the  
query in machine interpretable form and/or in natural  
35 language (e.g., English). At the remote database, the

- 14 -

Knowbot program may be stored during the querying of the database, and the querying of the database and the returning of the results may be controlled based on control information contained in the Knowbot program. A  
5 Knowbot service station may be used to create, send, receive, and delete Knowbot programs. At the remote database site, a Knowbot service station may be used to create, send, receive, control, process, and delete Knowbot programs. The remote database to which the  
10 Knowbot program will be sent is determined locally and automatically based on the local query. Sending the Knowbot program may include conforming the Knowbot program to an electronic mail protocol or a file transfer protocol or other communication method on the network.  
15 The Knowbot program protocol may include transformation information.

The Knowbot programs may include authentication information; scheduling information; and terms and conditions information.

20 Other advantages and features of the invention will become apparent from the following description and from the claims.

#### Description

Figure 1 is a block diagram of an Internet  
25 framework.

Figure 2 is a block diagram of a Knowbot framework.

Figure 3 is a block diagram of a Knowbot service environment.

30 Figures 4A and 4B are block diagrams of Knowbot service stations.

Figure 5 is a block diagram of a transaction manager.

Figure 6 is a block diagram of a gateway.

35 Figure 7 is a diagram of the contents of a Knowbot



- 15 -

program.

Figures 8 and 9 are block diagrams of serial and parallel search strategies.

Figure 10 is a diagram of a Knowbot program.

5 Figure 11 is a block diagram of a Knowbot service environment.

Figure 3 depicts the Knowbot service environment 50 which provides an extremely wide variety of functions 52a, 52b, ... for handling Knowbot programs 54a, 54b, ...  
10 via an essentially unlimited number and variety of Knowbot service stations 56a, 56b, ... each in the form of hardware and software running at a location on a distributed network. Examples of Knowbot service stations would include software running on an individual  
15 user's PC or laptop (service station 56a) or on a repository or database server of a participant that is a supplier of digital objects (service station 56e), or on a smart card or other personal digital equipment or artifact, or on a telephone company central office switch  
20 (service station 56b).

As seen in Figure 11 some of the most basic functions to be provided by the Knowbot service environment include aggregation and presentation services 170 which involve how information is collected and  
25 organized and presented to end user participants and how requests for tasks to be performed are elicited from end user participants 172; searching and consolidation services 174 which involve how queries are presented to repository participants 176 and other resources and how  
30 results are consolidated for presentation to these resources; and assurance/protection services 178 which validate the authenticity of Knowbot programs and Knowbot service stations and their performance, and that rights in digital objects will be effectively protected by these

- 16 -

programs and service stations in accordance with stated terms and conditions. These services are discussed in more detail below.

#### Knowbot Service Stations

5           The Knowbot service station is analogous to an operating system but does not allow participants to create arbitrary programs and files or to run arbitrary programs, although it could allow selected users with special system status great flexibility to manage the  
10 service station and to upgrade its performance. In general, the service station creates Knowbot programs in response to participant specifications and/or its own internal requirements. Prospective Knowbot programs may also arrive from external sources such as a user's PC  
15 that is not also a service station and can be authenticated by a service station for use in the Knowbot environment. Prospective Knowbot programs may also arrive on external media such as CD-ROM. The service station also processes Knowbot programs received from  
20 other service stations, and stores and manages Knowbot programs within its own environment.

As seen in Figure 4, the functions performed at each service station may generally fall into four major categories: i. basic administration 60 of Knowbot  
25 programs, include creating, sending, receiving, authenticating, executing, storing, monitoring and deleting them; ii. interaction 62 with a participant 63 to aid the participant in defining tasks to be done and to provide the results of doing tasks in forms and at  
30 times that are useful; iii. interaction 64 with a participant which is serving as a resource 65 in getting a task done, including conveying requests for information or actions in formats and at times that will be understood by the resource and processing the information  
35 or results of the actions; and iv. interacting with other

- 17 -

service stations 66 and interacting with hardware and software that is not part of the Knowbot framework to enable a limited set of external, possibly untrusted actions when appropriate and allowable.

5 Knowbot programs 54e through 54p may pass from Knowbot service station to Knowbot service station in the Knowbot service environment by a variety of mechanisms, for example by being transported in Internet packets. Knowbot programs 54q through 54t also may stay for  
10 periods of time in a given Knowbot service station and in that sense the host Knowbot service station may be thought of as a hotel and/or processing plant for Knowbot programs.

Referring to Figure 4B, the general structure of a  
15 generic Knowbot service station includes storage 60 for Knowbot programs and Knowbot program interpreters 62 for interpreting Knowbot programs written in languages such as (but not limited to) PERL or PYTHON. A core Knowbot operating system 68 provides basic key functions  
20 (discussed below) and provides a Knowbot operating system application program interface (API) 64 which provides a predefined interface to and thus enables application programs to be easily written to interact with the operating system. A Knowbot operating system extensions  
25 API 66 provides an interface to extensions 70. The extensions can include an almost limitless variety of services and functions that supplement the basic functions of the operating system, such as natural language processing.

30 Simple Knowbot service stations need only be able to perform a small set of basic functions and they may be implemented easily and in a straightforward way in the form of a software program or VLSI chip. Other more complex Knowbot service stations will have a variety of  
35 special functions suitable to their locations in the

- 18 -

network and to the entities with which they are expected to interact.

We turn to a discussion of a simple Knowbot service station with minimum basic functionality. As shown in Figure 5, the heart of the Knowbot service station is the transaction manager 70 which acts as a kind of traffic cop and status handler to supervise activities within the service station. The transaction manager interacts with a Knowbot program receiver 72 where Knowbot programs arrive at the service station, and with a Knowbot program transmitter 74 where outgoing Knowbot programs depart the service station. An input scheduler 76 keeps track of the arrival of Knowbot programs and assures that they are scheduled for handling in the service station at the appropriate time. An output scheduler 78 similarly keeps track of Knowbot programs that are to be sent out of the service station and assures that they are transmitted in due course.

Knowbot programs that arrive from an external source go directly to the receiver. The receiver provides access control and evaluates whether the incoming Knowbot program may properly enter the service station. If so, it stores the program in a store 82. If not it may discard the program or take some corrective action with respect to it. Knowbot programs that are generated locally, e.g., from a resource at the same location as the service station, are generated by or handled by a translator or by a specifier and are passed to the transaction manager for further disposition. The transaction manager may place the locally generated program in a store for subsequent processing or transmission, or it may hand it directly to the transmitter for immediate dispatch.

The input and output schedulers determine what action to take with respect to each entry in the Knowbot

- 19 -

program store. Actions could include performing steps called for by the program either immediately or at some later time or periodically or after some other event has occurred. When the time has come to perform such a  
5 processing step, the input scheduler notifies the transaction manager. When the time comes to transmit a program, the output scheduler notifies the transmitter.

The transaction manager manages all transactions in the service station and carries out periodic checks of  
10 status. It keeps track of ongoing transactions and notifies other service stations of status and error conditions (one way to provide the notice is by sending new Knowbot programs to the other service stations). The transaction manager maintains information about Knowbot  
15 programs created by the service station, and deletes Knowbot programs when appropriate. If it deletes a Knowbot program that originated in another service station it will generally notify the other service station of such action.

20 The transaction manager invokes the aid of an interpreter 84 to execute a Knowbot program. This may occur, for example, to determine whether a received Knowbot program is intended for a local user or for a local repository or for another site. The interpreter  
25 "interprets" the program (e.g., runs the Knowbot program) to determine what actions to take. If intended for a local user, the results of the interpretation are passed to a specifier which then communicates with the user. For example the specifier could deal with presentation  
30 matters such as what images can appear on a screen, or how many actions of a given type may be taken on behalf of the user. This information may be derived from the Knowbot program

If intended for a local repository 86 (e.g., if  
35 the task represented by the program is to access some

- 20 -

information in the repository), then the interpreted Knowbot program determines which repository to access and plans the execution method (e.g., serial or parallel, level of granularity, and how to order or combine the  
5 information). It then passes the results of the interpretation along with the program to one or more translators which then communicate with the repository. The translators convert the requests that are represented by the program to the language of the local repository.  
10 The local repository may be able to execute the request directly. If appropriate for another site then the transaction manager passes it to the transmitter for dispatch over the network to the intended site, which will generally be another service station but which may  
15 be a repository, a gateway, or some resource outside of the Knowbot service environment.

The repository search results would then be passed back through the translator which would format it, place it in the store 82, and notify the transaction manager.  
20 The transaction manager would then mark the transaction finished and make an entry in the output scheduler module.

The output scheduler provides a variety of return policies. Normally, the results would be returned in the  
25 form of a program in which case the transmitter 74 sends the program when and how indicated by the output scheduler. In addition, the results could be communicated in another medium (e.g., e-mail or file transfer) or made available in a suitable "markup  
30 language" for delivery. The markup language provides a self-describing form of information that denotes its substructure so that another interpretation is possible downstream. The results may be returned to the user or returned to a designated intermediate location for  
35 storage or processing.

- 21 -

A more complicated system 90, shown in Figure 6, could be used by a large provider of digital information stored in repositories 92a, 92b, ... to make services accessible to a variety of users. The users may wish to  
5 submit materials for inclusion in the repositories or to access information (digital objects, see below) held in the repositories. The service provider would maintain a gateway that would include a number of servers 94a, 94b, ... at least some of which would include Knowbot services  
10 stations 96a, 96b, ... as well as other software associated with the management of the repositories and the gateway. Each of the servers could have an IP address. The servers may be connected to one or more local area networks (LANs) 97, 98, which may also serve  
15 the repositories and a set of routers 99a, 99b, ... Each router would be connected to a communication link, including, for example, dial-up, wireless, X.25 link, or a connection to the Internet.

Users wishing to make queries to the repositories  
20 could form Knowbot programs which would first query an appropriate address server 102 to determine the IP address for the repository that could answer the query, and then would proceed to the router 99b. Router 99b would route the program to the appropriate one of the  
25 servers and the Knowbot service station there would interact with the appropriate repository to complete the query. Results could also be packaged in Knowbot programs and then returned via the Internet.

The Knowbot service stations in Figure 6 interact  
30 with one another for the purpose of coordinating search requests and other activities.

#### Logical Structure and Operation of Knowbot Programs

The logical structure of a Knowbot program is shown in Figure 7 in the form of fields of information  
35 that may be included to help guide the program through

- 22 -

the network and to provide instructions for its operation. The exact order of the fields is not significant and fields may be added or changed by the service stations as the Knowbot moves through the Knowbot  
5 service environment. In storage, various means of implementation are possible and many of the fields may be unnecessary and may be omitted.

The first field is a globally unique identifier 110 which distinguishes this Knowbot program from every  
10 other Knowbot program currently in existence in the Knowbot service environment. It may also be useful in distinguishing Knowbot programs over long periods of time. A portion of the identifier may be derived from the identity of the Knowbot service station that created  
15 the Knowbot program. The identifier may be used for retrieving a Knowbot program from storage or to refer to a Knowbot program. If the unique identifier has semantics, the Knowbot service station that created it will provide a type and version indicator to make clear  
20 what the semantics are, or this information may be contained in the system, time and date field mentioned below.

The globally unique identifier allows the existence, location, and activities of the Knowbot  
25 program to be controlled and determined with certainty while it exists in the Knowbot service environment.

The next (optional) field is authentication information 112 used to assure the authenticity of the Knowbot program, in particular that it was actually  
30 created by the environment that claims to have originated it. Portions or all of the Knowbot program may also be encrypted if desired.

The next field contains scheduling information 114 relating to when and how often the task represented by  
35 the Knowbot program is to be done. This may depend on



- 23 -

cost and time constraints set forth in the field. This field may also identify required status information (including error information notifications). The scheduling information will generally assume content  
5 specific information is located elsewhere in the program. The scheduling information could indicate, for example, when the Knowbot program executes functions, how long it should exist, and when and how it should return status information. Specific examples of instructions for  
10 starting a task include (a) "run this Knowbot program tomorrow at 2pm on repository X"; it might return a report on active Knowbot programs in the repository; (b) "run this Knowbot program everyday at noon on repository Y"; the results might be to say what has come in that is  
15 new that day; (c) "wait until event Z (e.g., we know which currency we want to use) and then run the Knowbot program using the results of that event," and (d) "run this Knowbot program and if event W occurs (e.g., the value of this stock ever goes below 15), take action Q  
20 (e.g., sell it), and if it goes above 20, buy it." The Knowbot program 174 may also include other wake-up criteria 182 and trigger conditions.

The next field, navigational information 116, may capture either information to control the future  
25 navigation of the program in the Knowbot service environment and/or information about the history of the navigational path taken by the program.

The next field, terms and conditions 118, relates to areas such as authorization of payment for tasks  
30 performed on behalf of the program or terms and conditions for use. This information is protected by use of public key encryption or some equivalent mechanism for authenticating payments and other terms and conditions. The payment information can indicate allowable credit  
35 limits, ensure authentication of payment, and may be

- 24 -

completely contained in the Knowbot program or may be associated with digital cash payment systems or other electronic payment mechanisms.

The next field, system, time, and date of creation  
5 120, provides a tracing mechanism in case the program is copied or a record of its history is needed. A program embedded in another program will have its own system, time, and date of creation. This field may also identify a Knowbot program that can acquire the information.

10 The next field, operation 122, typically would contain an instruction sequence to be executed in conjunction with the contents of the Knowbot program. Any language interpretable at the Knowbot service station is permissible. The instruction sequence could even be a  
15 digital representation of natural language (e.g., English) used in conjunction with a natural language understanding program to interpret it. Simple forms of the instruction sequence might be formatted search commands, or access commands such as "access object with  
20 identifier X," or "search for objects written by a specific named person." It may also identify a process to be carried out, such as "execute me and pass the results to the destination names in the results of the execution."

25 The next field, path 124, will generally identify the most recent service station to have handled the program, and it may also contain information about the series of service stations that previously handled the program along with the times when it was handled. In  
30 contrast to the navigation field which may contain incomplete information about future as well as previous trajectories, the path field is intended to yield the definitive record of the path actually taken.

The next field, description of data 126, will  
35 generally contain a unique identifier (known as a handle)

- 25 -

for data, the rights associated with use of each part of data (see below), reporting requirements (if any), and directions for using the instruction sequence. The directions may be in the form of an executable program.

5           The final field, data 128, contains one or more of the following:

          a.   a digital object, by which we broadly mean sequences of digits (e.g., binary digits or bits) and an associated unique identifier which we call a  
10 "handle". A digital object may incorporate information or material in which rights (e.g., copyright rights) or other rights or interests are or may be claimed. There may also be rights associated with the digital object itself. Thus digital objects may include digital  
15 representations of conventional works (e.g., literary or pictorial), and more broadly any digital material which is capable of producing desired manifestations for a computer user. Thus, a digital object could include programs and other data which may be based on or  
20 incorporate one or more preexisting works. The digital object may be delivered over a network and subsequently rendered on a computer screen (or other output device or devices, e.g., a printer) in whole or in part. Digital objects may include digital representations of audio,  
25 video or even 3-D scenes and artifacts, as well as bit sequences that have the potential to be rendered in many different ways and which renderings may be occurring for the first time. By the notion of rights which are or may be claimed in a digital object, we mean rights which  
30 exist under statute (e.g., copyright, patent, trade secret, trademark), or as a result of private action (e.g., via secrecy, cooperative ventures, or negotiation).

          b.   a sequence of bits (possibly with a data  
35 type)

- 26 -

c. indirect references to other entities  
(such as digital objects)

d. a set of the above

e. a combination of the above (including  
5 sets)

The contents description field allows the digital objects to be separately identified and processed with full cognizance of the rights and permissions associated with the contents. A digital object may itself be a  
10 Knowbot program.

Knowbot programs may communicate with each other as required to carry out tasks. Among the means for such communication are the following. 1. Multicast communication may be used to reach multiple other Knowbot  
15 programs or when the location of a target Knowbot program is not precisely known. 2. The source Knowbot program could send a message to a target Knowbot program by routing it via the Knowbot service station that created the target. 3. A mechanism could be used for direct  
20 communication from one Knowbot program to another.

In addition to a protocol or set of protocols defining how a Knowbot program is to be sent and received, the system may include a protocol or protocols defining how a message is to be sent and received. In  
25 some cases it may be more effective to send messages rather than to send the Knowbot programs themselves. E.g., a Knowbot program may arrive at a Knowbot service station and wait for a message from another Knowbot program before proceeding.

30 Knowbot programs may interact with each other in a Knowbot service station. Knowbot programs may be cloned in a Knowbot service station. Each Knowbot program clone may operate independently of its parent and siblings. Knowbot programs and their clones may coordinate their  
35 activities and cooperate in performing a task. More

- 27 -

generally any Knowbot program may coordinate its work with any other Knowbot program, whether or not they are clones.

Knowbot programs may be persistent, that is they  
5 may be created with the expectation that they will maintain a vigilant presence in the Knowbot operating environment. Usually the persistent Knowbot program will reside at a particular Knowbot service station, but there may also be persistent Knowbot programs that are  
10 perpetually moving through the Knowbot operating environment.

A Knowbot program carrying a simple user query or system query may produce a complex retrieval process or other distributed task execution. Several repositories  
15 or databases may have to be interrogated to obtain all the necessary components to satisfy the retrieval or other task execution. (A repository may contain multiple databases or knowledge bases). These components may be delivered to the user as a single response or as multiple  
20 responses. In certain cases, the user may require and the system may allow all or some of the components to be delivered separately.

A Knowbot program may carry out a complex task (possibly in conjunction with other Knowbot programs,  
25 repositories, databases and/or knowledge bases) that does not correspond to a query or a retrieval. For example, it may make something happen in the network, or in a computer, or a set of computers or the network such as activating programs, setting parameters, or inserting  
30 software patches.

#### Authentication and Security

Knowbot programs and Knowbot service stations within the Knowbot service environment may be designated as "qualified entities," that provide certain assurances  
35 on system behavior although such assurances may not be

- 28 -

possible for all service stations. Various levels of assurance may also be designated. For a service station, qualification amounts to registering the existence of the service station within the Knowbot service environment.

5 The party applying for such registration would agree not to modify (or otherwise tamper with) the service station except as authorized. The service station could contain mechanisms to determine its own integrity (e.g., if it has been altered or its operation otherwise modified).

10 Knowbot programs arriving at a qualified service station may be allowed to be handled there without regard for the qualification of the service station which originated the program, provided the cost of execution is acceptable. For executions that are costly, electronic  
15 payment may be required to be authorized or included. If digital objects subject to rights (e.g., computer programs) or relating to rights (e.g., contracts or deeds) are requested for access, the Knowbot program may only be allowed to be returned to qualified service  
20 stations at a certain level of trust. A test may be made prior to performing the access to determine if the source service station of the program is qualified or not. Or, in a less restrictive scheme, the program may simply be limited in what can be done with the digital object.

25 For Knowbot programs, qualification may mean simply that a qualified service station was the creator of the program, assigned it a globally unique identifier, and maintains a copy of the Knowbot program along with any associated information. When a Knowbot program is  
30 deleted, a status message is returned to the service station that created it. This message may be deferred in delivery if that station is not available. Other mechanisms for notification in the event of long-lived Knowbot programs and relatively short-lived stations  
35 involve transfer of responsibility by notification to

- 29 -

other stations.

A Knowbot program may itself be viewed as a digital object when stored in a repository maintained by or accessible to the service station which created it. A  
5 Knowbot program may be deleted at any time by any service station. The record of a Knowbot program may be deleted by the service station that created it, when it is no longer deemed useful to retain it.

Knowbot programs may request and/or receive  
10 digital objects which may be subject to claims of confidentiality or proprietary rights while resident in a given computer or while in transit over the network. Traditional network security technology such as public key encryption may be used for protection in transit and  
15 storage. The approach described here will assist in protecting digital objects during computer processing, subject to stated operations or types of usage. Certain informational material will have the requirement to have this form of protection while resident in the network  
20 environment. Only qualified service stations will be trusted to have access to this material. Knowbot programs resident in qualified service stations and in transit between qualified service stations are deemed to be trusted. Knowbot programs in all other environments  
25 and those not in transit between qualified service stations are assumed not to be trusted entities. Sources of Knowbot programs must be authenticated to insure that (in the return path) only qualified destinations can receive qualified Knowbot programs. Levels of  
30 qualification as well as encryption may also be designated and maintained with the system.

It is possible to use service stations and Knowbot programs without qualification, but there may be no guarantee made as to their ability to protect  
35 intellectual property.

- 30 -

A valid Knowbot program (e.g., one that has the required logical structure to be a Knowbot program) may be produced by any participant software that is capable of producing an appropriate Knowbot structure or meeting  
5 appropriate interface constraints to other software which can produce one. No constraints are placed on the participant side of the interface in creating a Knowbot program. The structure may also be in the form of an authorized or qualified Knowbot program if provided by or  
10 validated by an authorized or qualified Knowbot service station. The task description in a Knowbot program can be expressed in any language that can be interpreted, e.g., PERL scripts, PYTHON, and others. A Knowbot service station may support multiple language  
15 interpreters. A specific language interpreter may interpret certain structural portions of a Knowbot program expressed in another language. In any case, a qualified Knowbot program is only produced by a qualified Knowbot service station.

20 By operating within a qualified service station, qualified Knowbot programs are able to protect intellectual property in the Knowbot service environment. Requests for information from unqualified programs will only be fulfilled if the rights owners are willing to  
25 have their intellectual property sent to unqualified service stations. There is no technical restriction assumed to be placed on communication between unqualified programs or the type of activity that might take place. Thus, any information sent outside the qualified service  
30 station is subject to no further guarantees from a qualified service station. Such action will normally only be taken with the permission of the rights holder, if any. Such permission may be indicated in the terms and conditions field. Within the qualified service  
35 stations, however, rights and claims to rights will



- 31 -

continue to be protected.

#### Record Keeping

Each Knowbot program may contain, name, or point to none or one or more digital objects. These will  
5 generally be subject to rights and interests. Enough information is contained in a program to determine which operations are allowed to be performed on each digital object and the reporting that is required.

Knowbot programs may produce retrievals from  
10 repositories, operations upon themselves, interactions between programs, and deposits into repositories. They may also be sent to qualified service stations. In certain cases, where permitted by the rights holders, they may also be sent to unqualified service stations.

15 Each service station will keep track of operations performed on each Knowbot program and will report back electronically as appropriate (on usage according to the terms and conditions contained in the Knowbot program) to a "notification authority," a logically distributed  
20 system which is a key part of the Knowbot service environment or the rights administration process of the rights holder. In some cases, notification will be required each time a significant event or operation takes place (e.g. executing a task on behalf of a Knowbot  
25 program which is based on or incorporates information or material subject to rights). In other cases, only periodic reporting will be required (e.g. monthly or every N events).

If the notification authority's system goes off  
30 the network, reporting requirements may be suspended, although local collection of information for later reporting may still be required. Alternately, users may be restricted from executing on behalf of the Knowbot programs under such circumstances if the requested level  
35 of notification is not possible. For example, certain

- 32 -

applications may be time dependent and depend on replenishment of "electronic permits" over the network from the collection system (or more generally from a rights management system) in order to continue usage.

5           If a service station goes off the network and is not reconnected within a specified period of time, all Knowbot programs which must provide notification reporting may be rendered inoperable (for example due to service station storage constraints) until the service  
10 station is connected again and the notification system has been updated. Alternately, for this case a service station may be authorized by a rightsholder to remove any restrictions on activation of or reporting about Knowbot programs that contain any of his material. The Knowbot  
15 program could also be made to delete any reports that have been collected while disconnected from the collection station, if they are not needed.

#### Examples of Applications

20           The Knowbot framework enables a virtually endless variety of applications which make use of information stored in and services available at one or more computers in a network. The applications may perform complex tasks not limited to the typical simple access request for information on a single computer (e.g., at what network  
25 address should I send E-mail to Jim Daniels, or what is the public key for Jim Daniels?) or a single command to a remote server (e.g., issue a one-way plane ticket from Washington, DC, to San Diego for Jim Daniels anytime on the 3rd of March, 1998). Instead the Knowbot framework  
30 allows a participant to seek information or to accomplish tasks which may need to be accumulated from or performed at multiple computers according to a strategy not known in advance and in which later steps in the strategy depend on the results of earlier steps in the strategy.  
35 The framework enables all of this to be accomplished

- 33 -

transparently (or with notification, if requested) to the participant.

One broad class of applications involves responding to a single participant request for  
5 information which can only be obtained by accessing separate databases located at different remote locations on a network and assembling the information for coherent presentation to a user.

In a specific example, Fig. 8, assuming there is  
10 no central registry for obtaining Internet addresses, if a user at a local computer 130 wants the Internet address of another user, the first user would enter a single request 130 identifying the other user. The local Knowbot service station 138 would interpret the request,  
15 create a corresponding Knowbot program and send it to a series of other computers 132, 134, 136, each of which has its own Knowbot service station, and each of which is known to maintain a user address directory. (This may be known in advance if the local computer's service station  
20 has a table of the addresses of computers which maintain such directories; otherwise, the service station must get it by sending a Knowbot program first to a computer known to have such a table.) Each of the directories 138, 140, 142 on computers 132, 134, 136 is likely to have its own  
25 naming and addressing conventions. The service station at computer 130 may be set up so that the user's query is phrased in accordance with a common protocol, and the service stations at the other computers may include  
conversion routines that convert the incoming request at  
30 each directory from the common protocol to a form that permits direct querying of that directory. The result of the query may then be inserted into the Knowbot program, which then proceeds to the next directory. Each of the service stations serves temporarily as a "hotel" for the  
35 Knowbot program during the time when the query is being

- 34 -

executed there.

When the Knowbot program has completed its rounds and returns to computer 130 carrying the results of the multiple accesses, an extension or enhancement of the local service station may convert back from the common protocol to a format useful for local display of the information. The local service station enhancement may also organize the results in accordance with the user's preferences, before displaying them. For example the user may have asked for a display in reverse chronological order based on the most recent update of the entry, with the display showing the database or repository where each entry was found.

Having the Knowbot program perform this searching in round robin fashion as in Fig. 8 (i.e., serially, thus decentralizing task management) may take an unacceptably long period of time. An alternative scheme involves sending several Knowbot programs essentially simultaneously to the computers 132, 134, 136 and having them return independently to the originating computer 130 (as shown in dashed lines in Fig. 8) hopefully within a designated time-out period. This parallel approach to accumulating information (i.e., centralized task management) is especially important in reducing delay where the number of computers to be visited is large (as it often will be).

In another example, a user at a local computer may want to determine the current price of particular foreign long-term bonds in US dollars; the user may be unaware that this simple query actually requires fetching the price in a foreign currency and converting it to US dollars based on the current exchange rate. An extension or enhancement to the local Knowbot service station may provide a user interface that allows the user simply to phrase the problem to be answered, without naming the

- 35 -

pieces of information that must be fetched. The service station would send one or more Knowbot programs to the proper remote nodes to fetch the needed information.

Once the information has been returned, the local service  
5 station enhancement would use the current price and the conversion rate to determine the answer and would deliver the answer (but not necessarily the pieces of information) to the user. Since currency conversion may occur at multiple exchanges, the user will get an answer  
10 that is based on one (or more if desired) of the close but slightly differing exchange rates or upon an average of rates from several exchanges.

In this example, we assumed that the user would be able to formulate the problem to be solved, requiring  
15 only that the service station use Knowbot programs to get the missing pieces of information and then perform the computation. But suppose the user is only able to articulate the problem in non-mathematically precise words and needs help in converting the problem to a  
20 mathematical form and then solving it. The user could enter his query in words, e.g., "What is the likelihood of dollar sales for PCMCIA modems world-wide reaching \$50 million in 1999?" As seen in Figure 9, the local computer's service station extension or enhancement might  
25 first send a Knowbot program 151 to a remote service station 152 at a location which has an expert system 153 which contains knowledge on how to estimate dollar sales of a product. The program might carry a query along the lines of "What information do I need to know to answer  
30 the following question: ...?" The expert system 153 may provide the answer "Sales of the product in the past five years in the United States, population of the United States as a percentage of world population, and an estimate of the viability of the product in the face of  
35 specific new technology." Assuming that the answer also

- 36 -

gave addresses of computers where the answers could be found (if not, the Knowbot program would have to make visits to other computers to get that information), the Knowbot program could then, with the aid of the service  
5 station 152 spawn three new Knowbot programs 160, 162, 164 addressed to three other computers 154, 156, 158 where the information is located. The programs could be sent in parallel or a single program could be sent serially. When the information is returned to service  
10 station 152 embedded in Knowbot programs 166, 168, 170, the original Knowbot program, which may have been waiting at service station 154, may then cause the three spawned programs to be deleted, and carry the results back to the service station 150. The answer then could be generated  
15 and displayed.

The service stations and Knowbot programs offer a rich framework for controlling access to, use of, and compensation for digital objects located at computers in a way which should encourage creators of and other owners  
20 of rights in digital objects to make them available on the network. By the notion of rights in a digital object, we mean rights which exist under statute (e.g., copyright, patent, trade secret, trademark), or as a result of private action (e.g., via secrecy, cooperative  
25 ventures, or negotiation). Additional information concerning repositories and control of digital objects is set forth in United States Patent Application Serial Number 08/142,161, filed 10/22/93, assigned to the same assignee as this application, and incorporated by  
30 reference.

A creator or owner of a digital object typically will want to be able to control its use, reproduction, and accesses or performances, and to be compensated for permitting those acts. For example, the owner of a  
35 digital object whose data will manifest an image of

- 37 -

George Washington when interpreted by the receiver ("the George Washington data") 150 may wish to charge less for a single use by a high school teacher than for multiple uses by an advertising agency. To prevent the George  
5 Washington data sent to the high school from being delivered to an unauthorized third party, the Knowbot program used to carry an encrypted version of the data on the network to the high school may also carry instructions which, by interaction with the service  
10 station at the high school, restrict access to the encrypted data to a specified computer and for use with a specified registered copy of software at the high school.

A creator or owner of a digital object also may wish to receive reports on the uses, reproductions, and  
15 disseminations of its digital objects, for example to seek payment or to cross-check payments that have been received, or may merely wish to keep statistical information. Knowbot programs may interact with the service station to provide this service. In the George  
20 Washington data example, the owner may attach a price schedule to the data which is carried by the Knowbot program that is transporting it. The owner's Knowbot program may then, through interaction with the service station at the user's site, negotiate, in effect, with  
25 the purchasing computer with respect to a potential use for the data. Or the price may have been predetermined. If the customer agrees to a price, the owner's Knowbot program may permit access to the object and then report the new "purchase" to the owner.

30 The Knowbot program may use payment mechanisms already available on the network automatically to collect payment for ongoing uses of the digital object, according to a payment schedule that is either attached to the digital object (Knowbot programs could be stored in a  
35 repository with the digital object and the payment

- 38 -

schedule packaged together) or available elsewhere on the network. The owner of the George Washington data 150 could maintain a bank account or funds account on the network. The owner's Knowbot program could then conduct  
5 complete transactions with purchasers of the object, ending with the transfer of funds from the purchasers to the owners account on the network. The funds may take the form of direct money transfers, digital cash, or credit card (such as Visa or MasterCard) charges. In  
10 addition, other trusted authorization servers could be used.

The Knowbot program also could serve to control the use of a digital object as part of a derivative work being generated by a user. For example, the owner of the  
15 George Washington data could choose to permit a reduced resolution version of the representation to be altered for use in an on-line work about American history or a black and white representation to be created from a colored version. A Knowbot program could control access  
20 to the derivative work in the network, and could report the number of accesses back to the owner. The owner could arrange for the Knowbot program to take care of the payment transaction automatically, as discussed above. In general, Knowbot programs could retain information  
25 about the derivation trail of a derivative work.

The Knowbot program itself may be involved in the creation of derivative works based on existing works. This could involve the Knowbot program adding new material to an existing work recasting an existing work.

30 Just as the owner of a digital object wants to be paid for its use, the user of digital objects wants to make sure he does not unknowingly run up an intolerably high bill for accesses to digital objects. A Knowbot program sent out to accumulate information on a topic  
35 could automatically and without the sender's knowledge



- 39 -

run up fees for accessing digital objects at many remote locations in the network. For example, a user might launch a query that would have the inadvertent effect of seeking out and purchasing every available piece of  
5 information on sailboats. A service module could be included in the service station located at the requester's site which would prevent Knowbot programs launched by that service station from accumulating charges greater than some amount decided by the user via  
10 a screen-displayed form or it could help select the best set of sites to access for a given budget.

Another use for Knowbot programs could be in giving access to a combination of clinical data for a particular patient and a medical database. In a specific  
15 example, the Knowbot program would retrieve the patient's temperature and related information from the network and compare the temperature to applicable norms as described in the medical database. If the Knowbot program determines that the patient has a fever, the Knowbot  
20 program could access treatment information in the medical database and then find an appropriate treatment schedule all on the same mission.

Knowbot programs may be used for network support and assistance jobs. For example, a service station may  
25 serve as a layer of protection between a database and the information consumer, to prevent overloading of the database and to prevent intrusions that may damage the database. Knowbot programs could also help diagnose problems in the network. Knowbot programs may gather  
30 traffic, use, and system status information and then make reports on and also repairs to the network based on this information.

A database gatekeeper for Knowbot program inquiries would receive Knowbot inquiries in a buffer  
35 store and then apply the inquiries to the database at

- 40 -

regular intervals to help prevent overloading the system containing the database. In addition, the gatekeeper is designed to provide a layer of protection for the database against intrusions that may damage the database  
5 during handling of inquiries.

Existing database equipment and storage devices may be updated with new service station software and possibly new hardware to provide a standard Knowbot program interface to the storage devices without losing  
10 the value of existing equipment and data.

A Knowbot program sent from a service station may include or indirectly access a knowledge-based or expert system with knowledge inputted using rules, frames, and scripts and possibly natural language.

15 A Knowbot program may be used for administrative tasks such as managing library resources, organizing resources, characterizing data streams, coordinating among digital objects, determining structure of Knowbot programs, digital objects and other data, and building  
20 links among digital objects. A Knowbot program may be involved in managing interaction with distributed resources, including assisting in soliciting and managing bids. For example, the Knowbot program may ask the same question of a number of bidders and then organize the  
25 answers for the user. In another example, the user may authorize the Knowbot program to automatically select a bidder using a cost-to-quality ratio or similar formula. If the user is not especially concerned with quality, the Knowbot program automatically selects the lowest bid for  
30 the user. Alternatively, the Knowbot program is authorized to take the time of delivery into account.

A Knowbot program could be used to protect sensitive or confidential information. In this case, the terms and conditions might be based on the identity of  
35 the user and his need to know.

- 41 -

A Knowbot program may be involved in a smart directory service. The Knowbot program would take the user's profile and seek out and organize directory information for the user, updating the information as the user's profile changes. For example, if the user's profile reflects the user's interest in being aware of all Italian restaurants within a five-minute drive of the user's present location, the Knowbot program would update the user's directory entries for Italian restaurants as the user's location changes.

Knowbot service stations could include third-party value-added service providers that facilitate the transfer of information from information providers to information consumers. These third-party providers could be clearinghouses, catalogers, and routers; or "what's new" providers of information about new services and resources available on the network; or a reference information server that provides identification information about digital objects and other information in the network; or a browsing server that would help a user or a Knowbot program to find information based on only broad criteria about the desired information; or a query adviser that would help a Knowbot program in developing proper queries for representing a user's original search question; or a database rating service.

Service providers could maintain sophisticated computer programs, such as writing quality analyzers, oil exploration analyzers, and patent application analyzers, and use those works to provide value-added services on the network.

A Knowbot program created by an information provider could carry information from a repository, and then return to the information provider a confirmation of delivery.

As shown in Fig. 10, Knowbot programs may be

- 42 -

nested with a first Knowbot program 160 containing a second Knowbot program 162 which in turn holds retrieved information 164. The second Knowbot program helps the information provider with access control (e.g.,  
5 authorized execution, replication protection) because it can keep track of and control access (e.g., execution, replication) of the retrieved information. Also, the second Knowbot program may help with intellectual property protection because it can keep track of and  
10 limit access to retrieved information depending on the authorization of the party seeking access.

A Knowbot program may have as its mission the elimination of corrupted or garbage data or information from a system or network. It could do this by traveling  
15 from service station to service station at each of which it could examine programs located there for corrupt formats or lapsed lifetimes.

A Knowbot program could provide protocol conversion or other interpretation services between  
20 heterogeneous systems and applications. The intervening network need take no part in the conversion process.

An information provider such as a university which wants to make its journal articles accessible on a network could set up a Knowbot value-added service module  
25 as part of a service station. The module is accessed over the network (in natural language or some structured classification scheme) and the input received is used to guide a search of the repository for the digital representation of the articles, identify the relevant  
30 data to the potential consumer Knowbot program, and negotiate a sale. The consumer Knowbot program either has the capability of agreeing to terms and conditions or requiring that the data be sent to the user who then makes the decision about whether to purchase.

35 In another application, a Knowbot program visits a

- 43 -

story board generating program and then stores the requested story board. Next, the Knowbot program visits a music-generating program, a graphics-generating program, a text-generating program, and a video-  
5 generating program. The Knowbot program that returns to the user contains a computer program (sometimes called a multimedia work) or a digital representation of the components of the work that incorporates digital  
10 representations of the automatically generated components. A similar process could be used for producing other digital objects.

In another example, a Knowbot program acts on behalf of a user who wants to buy a bed for her bedroom and a table for her living room. The user's local  
15 service station has access to knowledge about the kinds of questions to ask of the user and generally where to find information. The service station drives an interactive program that obtains dimension information from the user, and also knows that it needs to find out  
20 who manufactures beds and tables. The service station sends a Knowbot program to learn about manufacturers and receives multiple answers.

In another illustration, multiple Knowbot programs contain instructions on what to do in reaction to the  
25 actions of other programs. This could be used in a war games simulation, where a Knowbot program would be analogous to a tank that has distinct properties and capabilities. Here the Knowbot program is an active ongoing entity whose existence continues throughout the  
30 simulation.

Such a scheme could be used in assisting the modeling of new complex systems such as a new airplane. Computations for modeling each part of the airplane, such as a wing, could be done separately and then the  
35 interactions of the parts could be managed through

- 44 -

Knowbot programs.

In the case of database queries, a Knowbot program could operate by taking a request for information from a form filled out by the user and then, for each database  
5 to be searched, converting the request with the aid of a specialized thesaurus in the service station, into the proper query format for that database.

Alternatively, each database could be associated with a service station having a standard Knowbot  
10 interface capable of receiving and understanding standard Knowbot program requests for information. The Knowbot program need only convert user requests into the standard format before making queries of a database. Using a standard format helps in maintaining the quality and  
15 integrity of the information retrieval capability. It also enables a data carrier entity to do business in information transfer, such as connecting a seeker of information with a source of information, without having to become involved in format conversion activities. The  
20 carrier entity is thus enabled to add value in addition to simply delivering the data, such as automatically connecting a consumer of a data service with the most cost-effective provider of the service.

- 45 -

What is claimed is:

1. A method for enabling tasks to be done on a network of multiple computers interconnected by communication links, comprising, at each of the computers  
5 receiving Knowbot programs on the communication links, each Knowbot program including a globally unique identifier; navigation information defining a route through the network; and information concerning a task to be done,  
10 advancing the execution of the tasks associated with the Knowbot programs,  
storing Knowbot programs,  
creating Knowbot programs, and  
transmitting Knowbot programs on the communication  
15 links.

2. A method for enabling a computer on a network of multiple computers interconnected by communication links to participate in a distributed Knowbot service environment, comprising, at the computer  
20 receiving Knowbot programs on the communication links, each Knowbot program including a globally unique identifier; navigation information defining a route through the network; and information concerning a task to be done,  
25 advancing the execution of the tasks associated with the Knowbot programs,  
storing Knowbot programs,  
creating Knowbot programs, and  
transmitting Knowbot programs on the communication  
30 links.

- 46 -

3. A computer-based method for carrying out tasks comprising interconnecting independent and heterogenous systems for the purpose of carrying out the collaborative tasks.

5           4. The method of claim 1 or 2 further comprising interacting with a participant at the computer to enable the participant to define the task to be executed, and

              embedding information related to the defined task  
10 in one of the Knowbot programs.

              5. The method of claim 4 wherein the participant comprises a person.

              6. The method of claim 4 wherein the participant comprises a process running on a computer.

15           7. The method of claim 4 wherein the participant comprises a Knowbot program running on a computer.

              8. The method of claim 1 or 2 further comprising, at the computer, interpreting task information contained in Knowbot programs.

20           9. The method of claim 1 or 2 wherein the step of advancing the execution of tasks includes interacting with repositories of digital objects.

              10. The method of claim 1 or 2 wherein the step of advancing the execution of a task includes querying a  
25 database of information or other data.



- 47 -

11. The method of claim 1 or 2 wherein the information concerning a task to be done includes interpretable or executable instructions.

12. The method of claim 1 or 2 wherein the step  
5 of advancing the execution of a task includes applying stored expert knowledge.

13. The method of claim 1 or 2 wherein the Knowbot program also contains data in the form of a digital object.

10 14. The method of claim 13 wherein the digital object includes protocol transformation information.

15. The method of claim 1 or 2 wherein the step of advancing the execution of a task includes protocol transformation.

15 16. The method of claim 1 or 2 wherein the step of advancing the execution of a task includes providing a directory service identifying other locations which provide services related to the task.

17. The method of claim 1 or 2 wherein the step  
20 of advancing the execution of a task includes making a security determination.

18. The method of claim 1 or 2 wherein the step of advancing execution of a task includes providing a "what's new" service.

- 48 -

19. The method of claim 1 or 2 wherein the step of advancing execution of a task includes providing a "clipping" or "abstracting" service.

20. The method of claim 1 or 2 wherein the step of advancing execution of a task includes providing a version control service for managing versions of the Knowbot program.

21. The method of claim 1 or 2 wherein the step of advancing execution of a task includes determining the structure of a Knowbot program and for accessing its elements.

22. The method of claim 1 or 2 wherein the step of advancing execution of a task includes responding to actions of a user by obtaining execution of the task at another location without indicating to the user that the execution occurred at the other location.

23. The method of claim 1 or 2 wherein the step of advancing execution of a task includes creating a derivative work from an existing work.

24. The method of claim 1 or 2 wherein the step of advancing execution of a task includes generating another Knowbot program.

25. The method of claim 1 or 2 wherein the step of advancing execution of a task includes passing a message from a source Knowbot program to a target Knowbot program at the same location or at a different location.

- 49 -

26. The method of claim 25 wherein the same message is passed to multiple Knowbot programs.

27. A method for executing a local query of a remote database via a communication channel of a network  
5 where the local query complies with a query protocol and the remote database is responsive to queries which comply with a database protocol, comprising  
locally generating a Knowbot program which is based on the local query and complies with a Knowbot  
10 program protocol,  
sending the Knowbot program to the remote database via the communication channel of the network,  
at the remote database, responding to the Knowbot program by querying the database in accordance with the  
15 database protocol, and  
returning the results of the query from the remote database within a return Knowbot program which complies with the Knowbot program protocol.

28. The method of claim 27 further comprising  
20 locally receiving the return Knowbot program, and providing results to a user based on the results contained within the return Knowbot program.

- 50 -

29. The method of claim 27 further comprising generating additional Knowbot programs which are based on the local query and comply with the Knowbot program protocol,

5 sending each of the additional Knowbot programs to another database, and

at each of the other databases, responding to the corresponding Knowbot programs by querying the other database, and

10 returning the results of the query from each of the other databases within a return Knowbot program which complies with the Knowbot program protocol.

30. The method of claim 27 further comprising locally receiving the return Knowbot programs, and

15 processing the results contained within the return Knowbot programs to provide a consistent presentation to a user.

31. The method of claim 30 wherein the consistent presentation to the user is updated as additional return

20 Knowbot programs are received.

32. The method of claim 30 wherein the processing includes removing redundant information.

33. The method of claim 27 wherein the return Knowbot program is a modified version of the original

25 Knowbot program.

34. The method of claim 27 wherein the additional Knowbot programs are generated locally and sent via communication channels of the network.

- 51 -

35. The method of claim 27 wherein additional Knowbot programs are sent locally and where return Knowbot programs corresponding to the original Knowbot program are received locally.

5 36. The method of claim 27 wherein the query protocol comprises a displayed form, completed by a user.

37. The method of claim 27 wherein the Knowbot program protocol differs from the query protocol and from the database protocol.

10 38. The method of claim 27 wherein the Knowbot program protocol comprises the syntax of an executable interpretive programming language.

39. The method of claim 27 wherein the Knowbot program comprises an executable interpretive programming  
15 language entry and a navigational portion.

40. The method of claim 39 wherein the Knowbot program reaches the remote database site by navigating the network, and wherein the navigational portion of the message comprises information related to the navigating.

20 41. The method of claim 27 further comprising at the remote database site sending a status Knowbot program indicating the status of execution of the query.

- 52 -

42. The method of claim 27 further comprising  
at the remote database, executing the Knowbot  
program to determine an appropriate database query,  
storing the Knowbot program during the querying of the  
5 database and controlling the querying of the database and  
the returning of the results based on control information  
contained in the Knowbot program.

43. The method of claim 27 further comprising  
locally using a Knowbot service station to create,  
10 send, receive, and delete Knowbot programs.

44. The method of claim 27 further comprising  
at the remote database site, using a Knowbot  
service station to create, send, receive, control,  
process, and delete Knowbot programs.

15 45. The method of claim 27 further comprising  
locally and automatically selecting the remote  
database to which the Knowbot program will be sent based  
on the local query.

46. The method of claim 27 wherein sending the  
20 Knowbot program includes conforming the Knowbot program  
to an electronic mail protocol or a file transfer  
protocol or other communication method on the network.

47. The method of claim 27 further comprising  
including in the Knowbot program protocol  
25 transformation information.

48. The method of claim 1 or 2 wherein the  
Knowbot programs further include authentication  
information.

- 53 -

49. The method of claim 1 or 2 wherein the Knowbot programs further include scheduling information.

50. The method of claim 1 or 2 wherein the Knowbot programs further include payment information.

5 51. The method of claim 1 or 2 wherein the Knowbot is persistent.

52. Apparatus for enabling tasks to be done on a network of multiple computers interconnected by communication links, comprising

10 a Knowbot service environment including, at each of the computers on the network, a Knowbot service station in the form of software running on a computer, the service station providing services which include

15 receiving Knowbot programs on the communication links, each Knowbot program including a globally unique identifier; navigation information defining a route through the network; and information concerning a task to be done,

20 advancing the execution of the tasks associated with the Knowbot programs, storing Knowbot programs, creating Knowbot programs, and transmitting Knowbot programs on the communication links.

- 54 -

53. Apparatus for enabling a computer in a network of multiple computers interconnected by communication links to participate in a distributed Knowbot service environment, comprising

5 a Knowbot service station in the form of software running on a computer, the service station providing services which include

- authenticating itself
- authenticating Knowbot couriers received from
- 10 other Knowbot service stations
- receiving Knowbot programs on the communication links, each Knowbot program including a globally unique identifier; navigation information defining a route through the network;
- 15 and information concerning a task to be done, advancing the execution of the tasks associated with the Knowbot programs,
- storing Knowbot programs,
- creating Knowbot programs, and
- 20 transmitting Knowbot programs on the communication links.



- 55 -

54. A method for executing a local query of a remote knowledge-based system via a communication channel of a network where the local query complies with a query protocol and the remote knowledge-based system is responsive to queries which comply with a knowledge-based system protocol, comprising
- locally generating a Knowbot program which is based on the local query and complies with a Knowbot program protocol,
- 10 sending the Knowbot program to the remote knowledge-based system via the communication channel of the network,
- at the remote knowledge-based system, responding to the Knowbot program by querying the knowledge-based system in accordance with the knowledge-based system protocol, and
- 15 returning the results of the query from the remote database within a return Knowbot program which complies with the Knowbot program protocol.
- 20 55. A method for retrieving a digital object from a remote system, in which
- the remote system embeds the object in a Knowbot program,
- the Knowbot program is sent to the local system, where it is stored,
- 25 the local participant accesses the digital object via the Knowbot program,
- the Knowbot program restricts access to portions of the object, requiring additional authorization and/or payment for access to the object, and the object's owner is notified as actions are performed on the object.
- 30

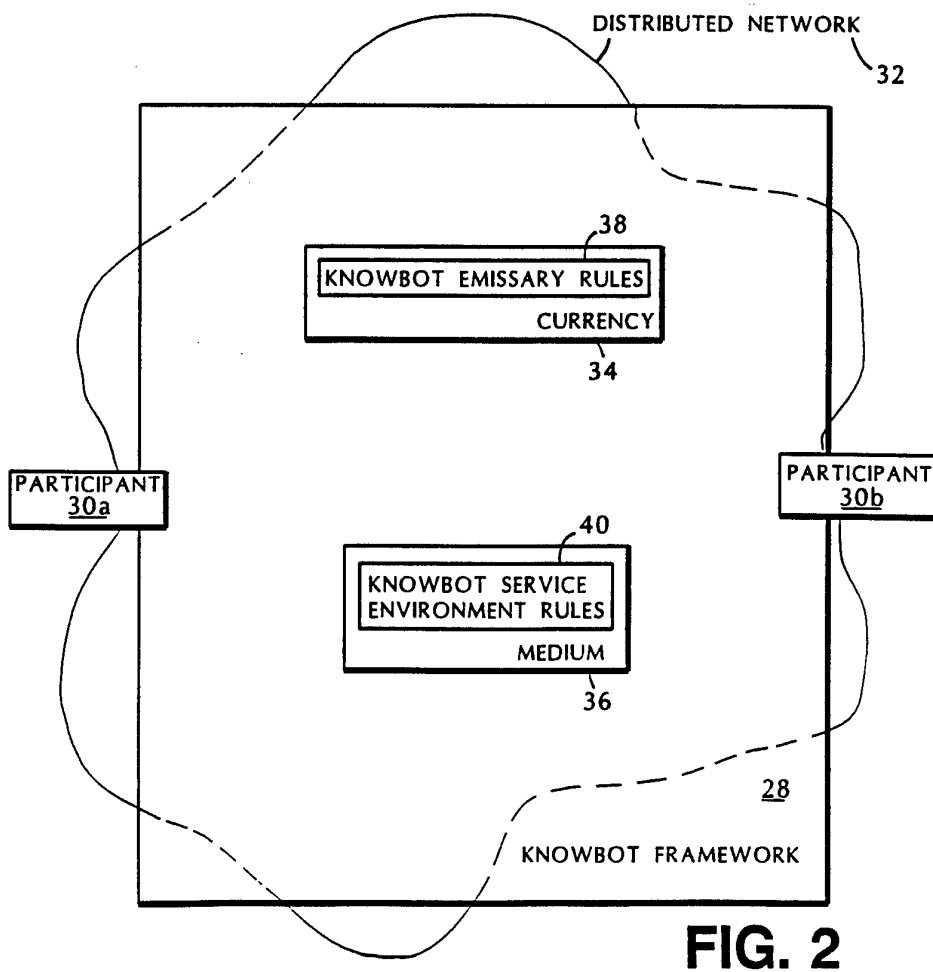
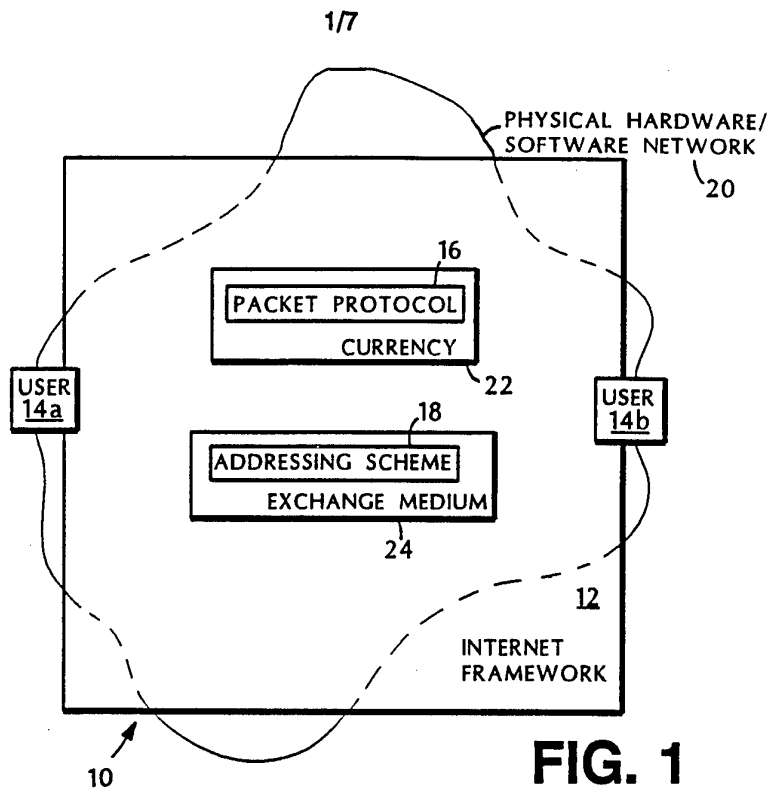

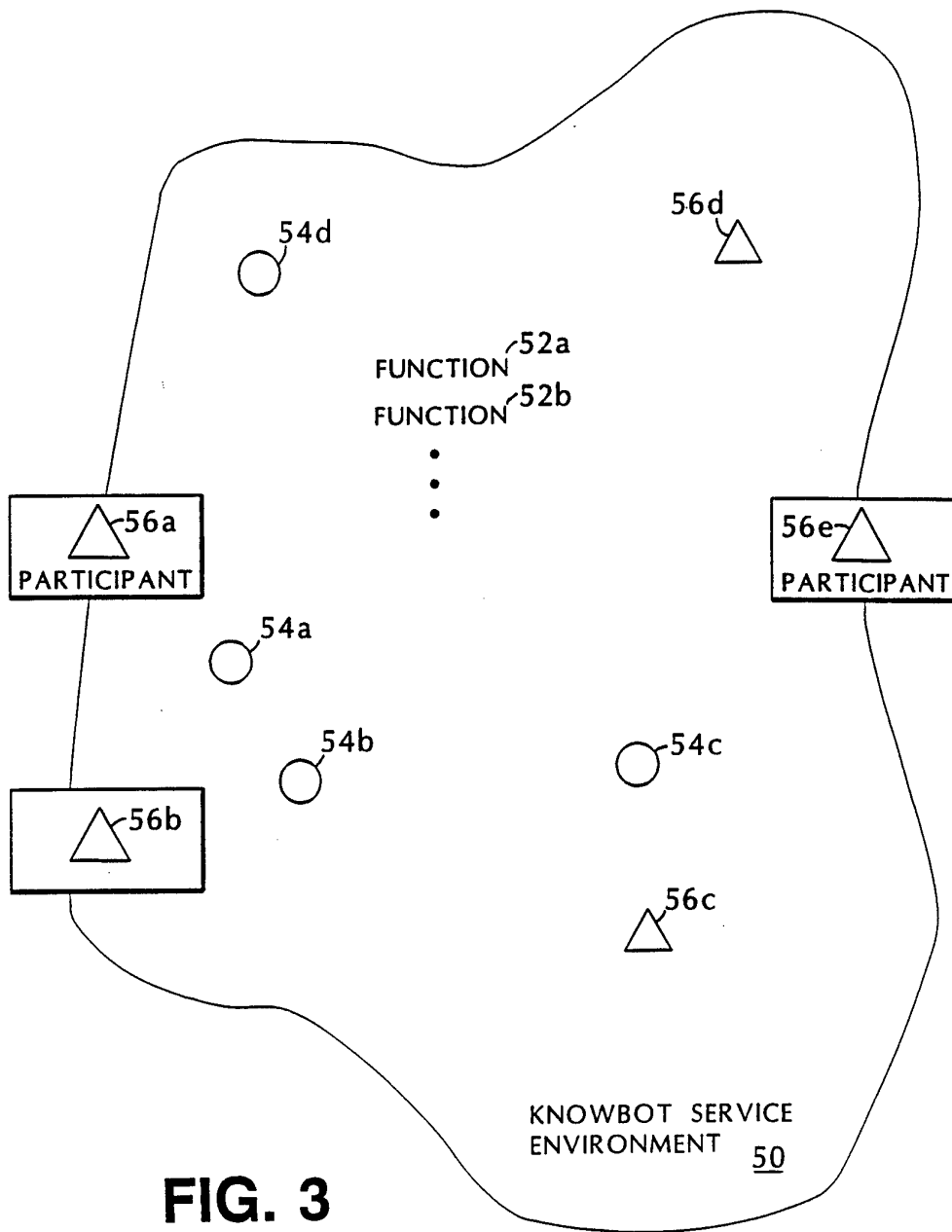

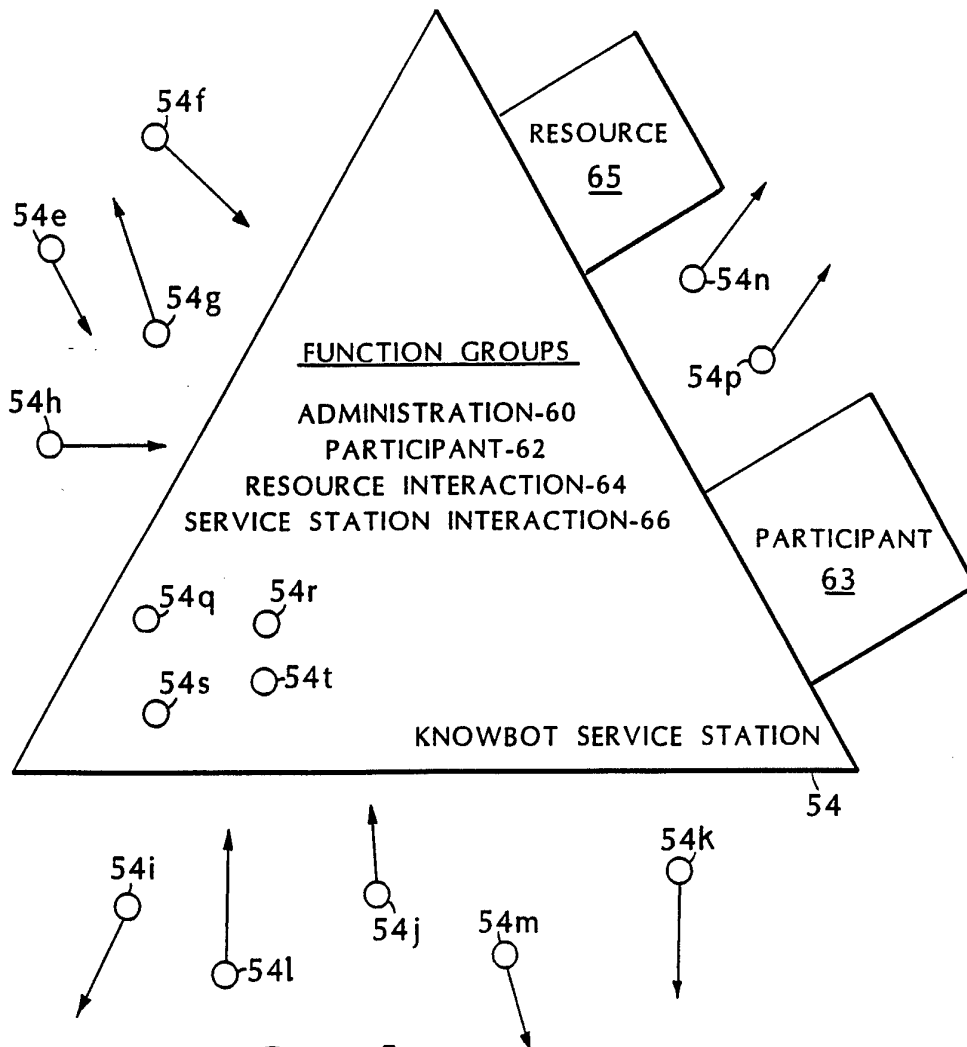

**FIG. 4A**



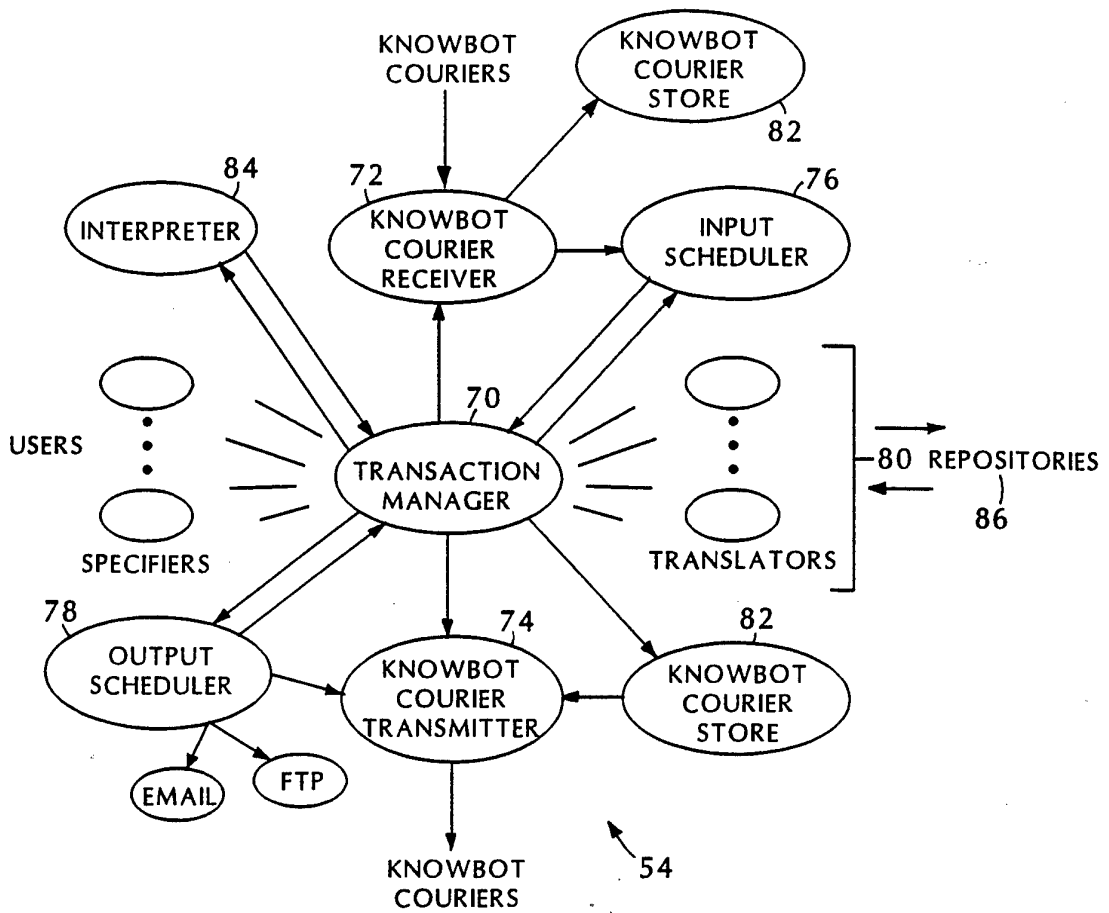

FIG. 5

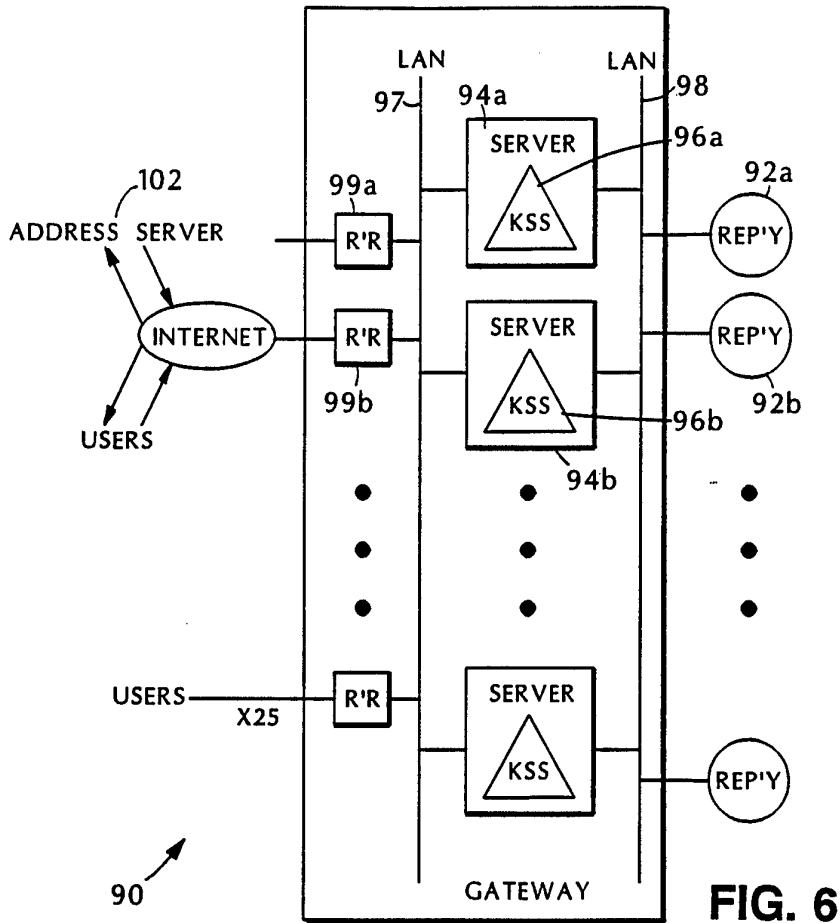

FIG. 6

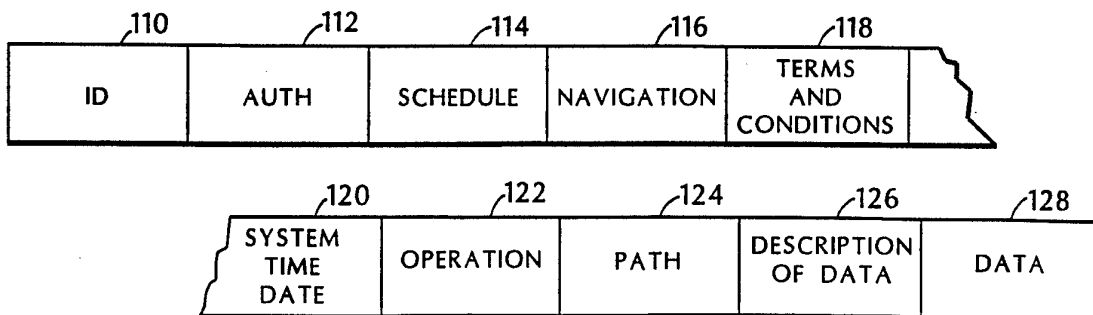

FIG. 7

7/7

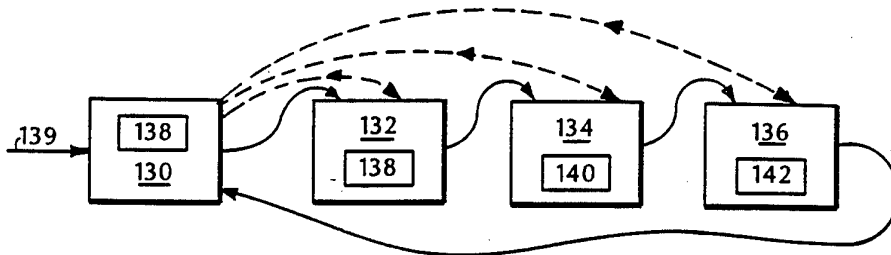

FIG. 8

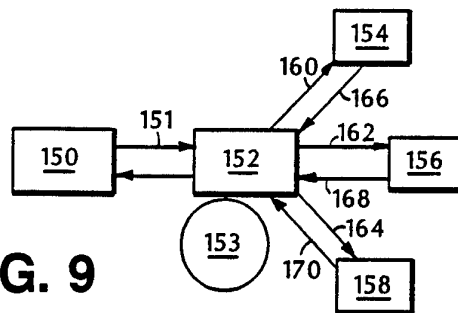

FIG. 9

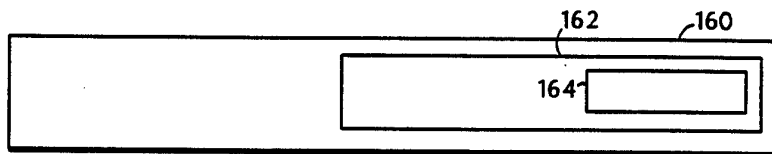

FIG. 10

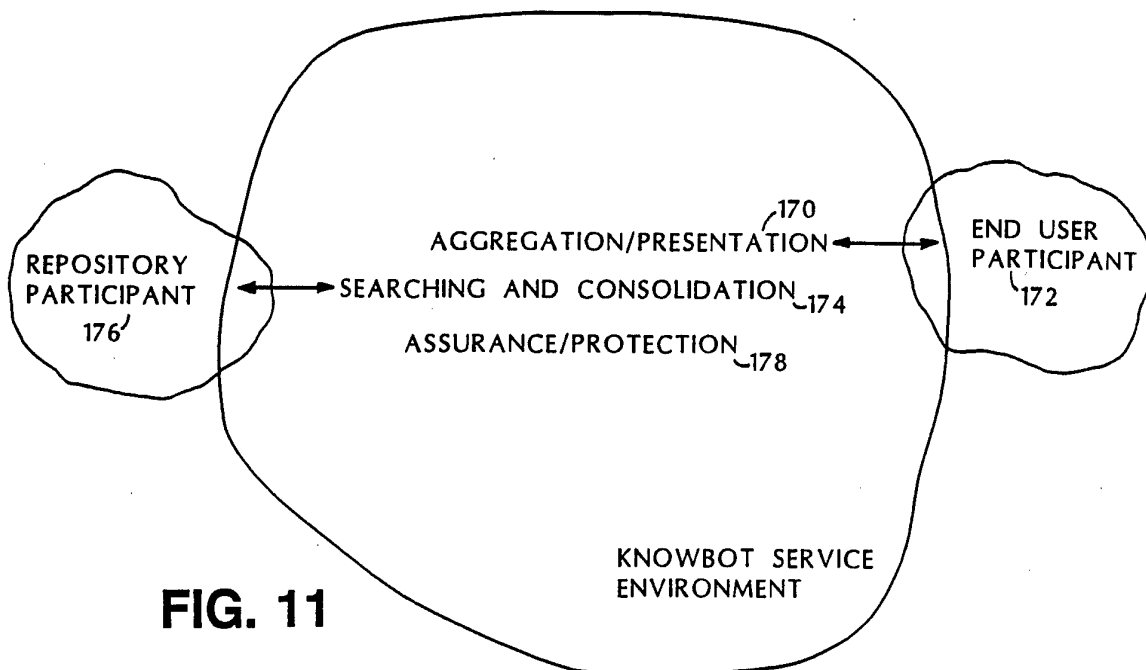

FIG. 11



**INTERNATIONAL SEARCH REPORT**

International application No.  
PCT/US96/08017

<b>A. CLASSIFICATION OF SUBJECT MATTER</b>		
IPC(6) :G06F 17/30, 13/00;H04L 12/54 US CL : 395/600, 700, 650, 51, 200.03 According to International Patent Classification (IPC) or to both national classification and IPC		
<b>B. FIELDS SEARCHED</b>		
Minimum documentation searched (classification system followed by classification symbols) U.S. : 395/600, 700, 650, 51, 200.03		
Documentation searched other than minimum documentation to the extent that such documents are included in the fields searched		
Electronic data base consulted during the international search (name of data base and, where practicable, search terms used) APS, DIALOG (COMPSCI, PATENTS), PROQUEST SEARCH TERMS: KNOWBOT, INTELLIGENT AGENT, SOFTWARE AGENT, COOPERATIVE AGENT, SOFTBOT, KNOBOT, OLIVERS, SOFTWARE ROBOT		
<b>C. DOCUMENTS CONSIDERED TO BE RELEVANT</b>		
Category*	Citation of document, with indication, where appropriate, of the relevant passages	Relevant to claim No.
A	US, A 5,390,281 (Luciw et al.) 14 February 1995	1-55
A	US, A 5,423,043 (Fitzpatrick et al.) 06 January 1995	1-55
A	PC-Computing, Vol. 3, No. 1, January 1990, Steinberg, D., pp 135-136.	1-55
A	Computerworld, Vol. 25, No. 19, May 13, 1991, Gary H. Anthes, "Let Your Knowbots do the Walking", p. 17.	1-55
A	INTERNETWORK, Vol. 5, No. 12, December, 1994, Joe Paone, "Navigating the Internet Seas", pp 56-57.	1-55
<input checked="" type="checkbox"/> Further documents are listed in the continuation of Box C. <input type="checkbox"/> See patent family annex.		
* Special categories of cited documents:	"T"	later document published after the international filing date or priority date and not in conflict with the application but cited to understand the principle or theory underlying the invention
"A" document defining the general state of the art which is not considered to be part of particular relevance	"X"	document of particular relevance; the claimed invention cannot be considered novel or cannot be considered to involve an inventive step when the document is taken alone
"E" earlier document published on or after the international filing date	"Y"	document of particular relevance; the claimed invention cannot be considered to involve an inventive step when the document is combined with one or more other such documents, such combination being obvious to a person skilled in the art
"L" document which may throw doubts on priority claim(s) or which is cited to establish the publication date of another citation or other special reason (as specified)	"&"	document member of the same patent family
"O" document referring to an oral disclosure, use, exhibition or other means		
"P" document published prior to the international filing date but later than the priority date claimed		
Date of the actual completion of the international search	Date of mailing of the international search report	
22 JULY 1996	08 AUG 1996	
Name and mailing address of the ISA/US Commissioner of Patents and Trademarks Box PCT Washington, D.C. 20231	Authorized officer <i>B. Havel</i> PAUL R. LINTZ	
Facsimile No. (703) 305-3230	Telephone No. (703) 305-9600	

## INTERNATIONAL SEARCH REPORT

International application No.

PCT/US96/08017

C (Continuation). DOCUMENTS CONSIDERED TO BE RELEVANT		
Category*	Citation of document, with indication, where appropriate, of the relevant passages	Relevant to claim No.
A	Proceedings IEEE International Workshop on Robot and Human Communication, Tokyo, Japan, 1-3 September 1992, Fujiki et al., "A Prototype of Goldfish Software Robot with Real-Time Response Function by a Parallel Computer", pp. 323-328.	1-55
X	OMNI, "Interview - Robert E. Kahn", December, 1992, pp. 83-85, particularly p. 84, column 3, lines 24-33.	1-54
Y	Preliminary Report, Department of Computer Science, University of Washington, Seattle, Washington, November, 1992, Oren Etzioni et al., " Building Softbots For UNIX", pp. 1-19, especially pp.3-14	1-54
A	Communications of the ACM, Vol. 35, No. 12, December 1992, Larry Press, "The Net: Progress and Opportunity. (The Internet and the Global Network to Which it is Connected)"pp. 21-26.	1-55
A	MacWeek, Vol. 7, No. 6, 8 February 1993, Mitch Ratcliffe, "General Magic Will do its Trick on Macs, PDAs", pp1-3.	1-55
A	Computer, Vol. 26, No. p, September 1993, Obraczka et al., "Internet Resource Discovery Services", pp. 8-22.	1-55
A	Proceedings of the Twenty-Eighth Hawaii International Conference on System Sciences, Wailea Hawaii, 3-6 January 1995, King et al., "Competitive Intelligence, Software Robots, and the Internet: The NewsAlert Prototype", pp. 624-631.	1-55