



INTERNATIONAL APPLICATION PUBLISHED UNDER THE PATENT COOPERATION TREATY (PCT)

<p>(51) International Patent Classification ⁵ : F02D 11/10, 41/22, B60Q 1/44</p>	<p>A1</p>	<p>(11) International Publication Number: WO 91/04400 (43) International Publication Date: 4 April 1991 (04.04.91)</p>
--	------------------	---

(21) International Application Number: PCT/EP89/01099
(22) International Filing Date: 21 September 1989 (21.09.89)

(71) Applicant (for all designated States except US): ROBERT BOSCH GMBH [DE/DE]; Postfach 10 60 50, D-7000 Stuttgart 10 (DE).

(72) Inventors; and
(75) Inventors/Applicants (for US only) : KULL, Hermann [DE/DE]; Novalisstaffel 1, D-7000 Stuttgart 1 (DE). BERGER, Joachim [DE/DE]; Falkenstr. 11, D-7065 Winterbach (DE). GERSTUNG, Ulrich [DE/DE]; Hölderlinstr. 28, D-7143 Vaihingen/Enz (DE). BLEUEL, Klaus [DE/DE]; Badbrunnenstr. 68, D-7000 Stuttgart-Bad Canstatt (DE).

(81) Designated States: AT (European patent), BE (European patent), CH (European patent), DE (European patent)*, FR (European patent), GB (European patent), IT (European patent), JP, LU (European patent), NL (European patent), SE (European patent), US.

Published
With international search report.

(54) Title: SUPERVISORY SYSTEM FOR A VEHICLE ACCELERATOR PEDAL TRAVEL TRANSDUCER

(57) Abstract

In a supervisory system for the accelerator pedal transducer (26) in an EMS for a vehicle engine, the output signal (U-FFG) of the transducer (26) is interpreted to show whether or not the transducer is at or close to the idling position. The resulting information is compared with the states of idling and pressure switches (18, 28) which shows whether or not the accelerator pedal (30) is actually at or close to its idling position. A contradiction resulting from this comparison indicates a fault and remedial action can be taken by the EMS, e.g., to reduce the engine power to a precautionary value. A contradiction between other comparisons shows that one of the switches (18, 28) is faulty. In the event of the accelerator pedal sticking in a depressed position after the driver has lifted his foot and depressed the brake (Fig. 5) a brake signal (BS) can be passed through a gating circuit controlled by the idling switch signal (FFG-LL) to produce a reaction signal (RS). The EMS processes the latter to reduce the engine power to a precautionary safe value.

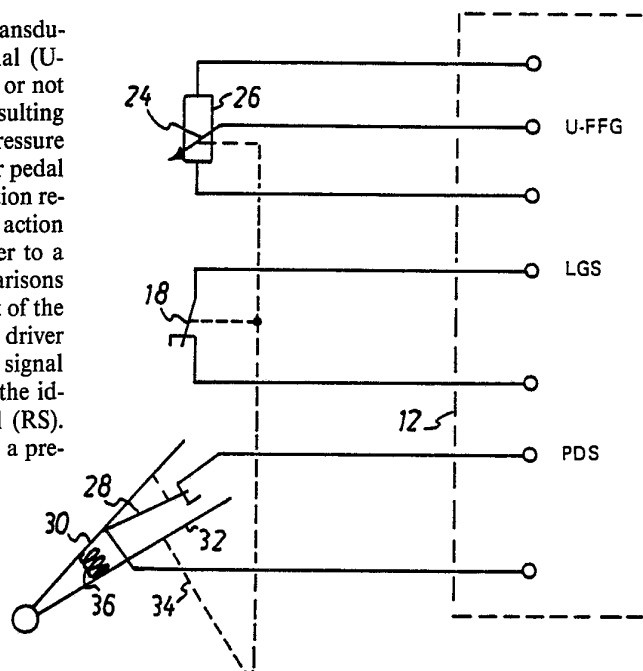

* See back of page

DESIGNATIONS OF "DE"

Until further notice, any designation of "DE" in any international application whose international filing date is prior to October 3, 1990, shall have effect in the territory of the Federal Republic of Germany with the exception of the territory of the former German Democratic Republic.

FOR THE PURPOSES OF INFORMATION ONLY

Codes used to identify States party to the PCT on the front pages of pamphlets publishing international applications under the PCT.

AT	Austria	ES	Spain	MC	Monaco
AU	Australia	FI	Finland	MG	Madagascar
BB	Barbados	FR	France	ML	Mali
BE	Belgium	GA	Gabon	MR	Mauritania
BF	Burkina Fasso	GB	United Kingdom	MW	Malawi
BG	Bulgaria	GR	Greece	NL	Netherlands
BJ	Benin	HU	Hungary	NO	Norway
BR	Brazil	IT	Italy	PL	Poland
CA	Canada	JP	Japan	RO	Romania
CF	Central African Republic	KP	Democratic People's Republic of Korea	SD	Sudan
CG	Congo	KR	Republic of Korea	SE	Sweden
CH	Switzerland	LI	Liechtenstein	SN	Senegal
CM	Cameroon	LK	Sri Lanka	SU	Soviet Union
DE	Germany	LU	Luxembourg	TD	Chad
DK	Denmark			TG	Togo
				US	United States of America

- 1 -

DESCRIPTION"SUPERVISORY SYSTEM FOR A VEHICLE ACCELERATOR PEDAL
TRAVEL TRANSDUCER"State of the Art

The invention relates to a supervisory system for monitoring the accelerator pedal travel transducer in an electronic control system for a combustion engine (internal or external), in accordance with the preamble to claim 1.

An electronic control system to which the invention may be applied is described in an article entitled "Elektronische Motorsteuerung fuer Kraftfahrzeuge " published in "MTZ" Motortechnische Zeitschrift, year 46, Vol. 4, 1985, published by Franckh'sche Verlagshandlung Stuttgart. In this article, it is explained that electronic engine control (called "EMS" for short) means a system in which the conventional mechanical linkage between the accelerator pedal and the element (the throttle valve in a petrol engine or the regulating rod in a diesel injection pump) determining the engine output is replaced by an electrical connection comprising a pedal travel transducer (potentiometer) actuated by the accelerator pedal and an actuator (servomotor) actuating the said element.

The above article describes in particular a system (now sometimes called "E-gas") in which the servomotor adjusts the throttle valve in a carburettor or petrol injection engine. DE-A-3301742 and DE-A-3301743 describe supervisory systems of the initially recited kind which are used for electronic diesel control (EDC). The two German patent specifications disclose the use of a separate switch for detecting whether or not the accelerator pedal is in its idling position. The EDC performs a "signal-range check" to monitor the

-2-

occurrence of faults in the operation of the system. Amongst other parameters, the accelerator pedal position is monitored and, for the purpose of the signal-range check, a separate idling switch, actuated when the accelerator pedal is in its idling position, may be used rather than the pedal travel transducer. The purpose of carrying out the signal-range check on the accelerator pedal position is to ensure that appropriate measures are taken by the EDC to prevent too large an injected fuel quantity if a fault should occur in the pedal travel transducer whereby the latter gives a signal corresponding to a substantially greater injected fuel quantity than is desired by the driver.

Disadvantages of the supervisory systems described in DE-A-3301742 and DE-A-3301743 are that they cannot respond to all fault conditions and cannot pinpoint faults when they occur, e.g., in the accelerator travel transducer.

The invention also relates to a supervisory system for monitoring accelerator pedal travel transducer in an electronic control system for a combustion engine in accordance with the preamble to claim 11.

Such a system is briefly described in EP-A-0109478. However, such a system lacks reliability in that it does not necessarily fail safe. Should one of the connections to the idling switch be broken, this may not show up and the supervisory system can then not respond to a sticking travel transducer.

The invention furthermore relates to a supervisory system for the accelerator pedal travel transducer in an electronic control system for a combustion engine installed in a vehicle, in accordance with the preamble to claim 19.

Such a system is described in DE-A-3531198. In

-3-

this system the brake switch, which may be the stop-light switch, is used as a redundant switch for producing a brake signal (BS) which is used to monitor the operation of the idling switch associated with the accelerator pedal. Operation of the brake normally implies that the driver has released the accelerator pedal so that the latter should already be in its idling position. The output signal (LGS) from the idling switch is processed in the EDC in addition to the output signal (U-FFG) from the pedal travel transducer. The brake signal (BS) may also be used to switch off automatic velocity control when the EDC is designed for such control.

However, it has hitherto not been possible to take appropriate measures in an EMS in the event of the accelerator pedal sticking in a depressed position, e.g., due to a foot mat being rucked up, or the accelerator pedal travel transducer sticking, although the latter event can be detected if the idling switch is structurally independent of the travel transducer.

Advantages of the invention

The above disadvantages can be mitigated by adopting the features of the characterising clause of claim 1. Enhanced redundance is obtained through the use of a pressure switch separate from the travel transducer. The computer logic can correctly diagnose the locality of a fault and in this respect, supervision of the redundant components is important as otherwise a fault in the redundant signals would lead to a complete absence of safety.

A simple arrangement is achieved by adopting the feature of claim 2 and claim 3 is directed to an advantageous feature.

By adopting the feature of claim 4, two redundant

-4-

signals are obtained, whereby the reliability of the supervision is further improved. Although the increased complexity resulting from the provision of two switches rather than one leads to an increased possibility of a fault arising in the supervisory system itself, e.g., cable faults, it is possible to detect a fault in a switch or in its circuitry and to exclude the defective redundant signal during continued monitoring. The driver can thereby be warned of the presence of a fault but can carry on driving normally with continued supervision of the pedal travel transducer.

Further reliability is obtained in accordance with the features of claims 5 to 7 and/or in accordance with claims 8 and 9.

Greater reliability is achieved if the idling switch is closed in the idling position and is opened upon depression of the accelerator pedal, in accordance with claim 11.

Further advantageous features are recited in claims 12 to 17.

An improved system for detecting the sticking of the accelerator pedal in a depressed position is obtained by adopting the features of the characterising clause of claims 18 and 19.

Preferably, the reaction signal is used to reduce the engine power to what is considered to be a safe value, in accordance with claim 20.

It is recommended that the reaction signal be effective to reduce the power output only after a short delay in accordance with claim 21 and it is advantageous to reduce the power along a "ramp", in accordance with claim 22.

Similarly, claims 23 to 25 are directed to further advantageous features.

Drawings

The invention is further described, by way of example, with reference to the accompanying drawings, in which:-

Fig. 1 is a circuit diagram of a supervisory system for monitoring an accelerator pedal travel transducer,

Fig. 2 is a graph relating to the embodiment of Fig. 1 in which the transducer output is plotted against the detected travel,

Fig. 3 is a diagrammatic illustration of the arrangement of a pressure switch in accordance with the invention,

Fig. 4 is a graph, similar to Fig. 2, but relating to the embodiment of Fig. 3,

Fig. 5 is a circuit diagram of a supervisory system for monitoring sticking of the accelerator pedal,

Fig. 6 is a graph illustrating the operation of the system of Fig. 5,

Fig. 7 is a circuit diagram of an embodiment of supervisory system employing two redundant signals,

Fig. 8 is a diagram of a circuit for checking whether a pedal pressure switch has stuck in the idling position,

Fig. 9 is a diagram of a circuit for checking whether the pedal pressure switch has stuck in the full or partial load position, and

Fig. 10 is a graph, similar to that of Fig. 2, but relating to the embodiment of Figs. 7 to 9.

Description of the preferred embodiments

Fig. 1 shows a supervisory system for the accelerator pedal 10 of an electronic engine control (EMS) for a mechanically propelled vehicle. The EMS includes a main computer 12 by means of which the engine power is controlled in accordance with the position of

-6-

the accelerator pedal 10 and in accordance with operating parameters, such as engine speed. Such an EMS for a diesel engine is described in DE-A-3531198 and one for a petrol engine is briefly described in the above-mentioned article by Gerhard Kolberg.

The accelerator pedal 10 is mechanically coupled to the slider 14 of a potentiometer 16 which serves as the accelerator pedal travel transducer. The ends of the potentiometer are connected between a 5V source and earth in the main computer 12 and the pedal position signal U-FFG appearing on the slider 14 is processed in the computer 12 to set the injected fuel quantity in the case of a diesel engine or to set the air inlet throttle valve in the case of a petrol engine, in accordance with the driver's wishes.

The accelerator pedal 10 is also mechanically coupled to an "idling" switch 18 one pole of which is connected via a resistor 20 in the computer 12 to a 5V source and the other pole of which is connected to earth. The switch 18 is a normally-closed switch and is opened as soon as the accelerator pedal 10 has been depressed a short distance. Thus an idling position signal FFG-LL appears as earth potential on the terminal LGS of the resistor 20 when the pedal 10 is at or very close to its idling position whereas a pedal-actuated signal FFG-LL appears as a 5V potential on the resistor terminal LGS when the driver depresses the accelerator. The idling switch 18 is used to monitor the operation of the pedal travel transducer 16.

As shown in Fig. 2, the transducer output voltage U-FFG is proportional to the position of the slider 14 which is dependent on the depression of the accelerator pedal. This output voltage is divided into five ranges, namely

-7-

range 1 : $U\text{-FFG} < U\text{-FFG-MIN}$ range 2 : $U\text{-FFG-MIN} < U\text{-FFG} < U\text{-FFG-LLU}$ range 3 : $U\text{-FFG-LLU} < U\text{-FFG} < U\text{-FFG-LLO}$ range 4 : $U\text{-FFG-LLO} < U\text{-FFG} < U\text{-FFG-MAX}$ range 5 : $U\text{-FFG-MAX} < U\text{-FFG}$

where U-FFG-MIN and U-FFG-MAX are the transducer output voltages when the accelerator pedal is against its idling and full load stops, respectively, and U-FFG-LLU and U-FFG-LLO are the transducer output voltages at the minimum and maximum ends of the tolerance range for the opening or closing of the idling switch in relation to the transducer output voltage U-FFG during the first part of the pedal travel away from its idling stop. Table 1 is a plausibility diagram representing the operation of the supervisory system of Fig. 1.

TABLE 1

actual transducer output voltage (U-FFG)	idling switch	processed value or symptom	diagnosis
range 1	{ LL	idling speed (optional)	faulty transducer
	{ LL	elevated idling speed	faulty transducer
range 2	{ LL	U-FFG	-
	{ LL	elevated idling speed	faulty transducer or faulty switch
range 3	{ LL	} U-FFG	-
	{ LL		
range 4	{ LL	elevated idling speed	faulty transducer or faulty switch
	{ LL	U-FFG	-
range 5	{ LL	idling speed (optional)	faulty transducer
	{ LL	elevated idling speed	faulty transducer

Table 1 demonstrates the ability of the supervisory system to respond to faults in the pedal transducer and in the idling switch, provided that the idling switch switches over within the prescribed tolerance band and provided that the output voltage U-FFG of the pedal transducer is within the prescribed tolerance band for all positions of its slider. This last feature is not shown in Fig. 2 but may be deduced therefrom. In known systems it is not possible to detect the fault that the idling switch has stuck in its full load position.

It is advantageous from the point of view of likelihood of failure that the idling switch 18 closes to earth in the idling position and is connected via a resistor 20 to a voltage source (failure mode and effects analysis).

In relation to a pure signal-range check, improved emergency or stand-by driving conditions can be obtained, in that a speed at least between idling and elevated idling can be selected when there is a signal-range fault with the redundant signal (optional digital function indicated in Table 1).

In Figs. 1 and 2 and in Table 1, it is assumed that the idling switch is directly coupled to the accelerator pedal travel transducer, whereby the latter must be displaced slightly from its idling position before the idling switch is actuated. A higher degree of redundancy can be obtained by making the idling position switch 28 completely separate from the travel transducer 26, as shown in Fig. 3. The accelerator pedal 30 is made separate from a pedal lever 32 and acts on the latter via the idling position switch 28, which is hereinafter referred to as a pressure switch, inasmuch as it is responsive to pressure applied to the pedal

-10-

30. The pedal lever 32 acts via a connecting rod 34 on the slider 24 of the potentiometer 26, serving as the travel transducer. A light return spring 36 acts between the pedal lever 32 and the pedal 30.

Initially, the pedal 30 is in a position, as shown, which can be said to be a position below idling position. When the driver first depresses the pedal 30, an initial tolerance clearance between the pedal 30 and the pressure switch 28 which is shown mounted on the lever 32 is taken up. Further depression of the pedal 30 actuates the pressure switch 28. Only after the switch travel is taken up does the pedal lever 32 begin to move and thereby displace the travel transducer 26 from its idling position. The effect is shown in the graph of Fig. 4 and Table 2 below, wherein the symbols have the same meaning as in Fig. 2 and Table 1.

TABLE 2

actual transducer output voltage (U-FFG)	pressure switch	processed value or symptom	diagnosis
range 1	{ LL	idling speed* elevated idling speed	faulty transducer
	{ LL		
range 3	{ LL	U-FFG	-
	{ LL		
range 4	{ LL	elevated idling speed* U-FFG	faulty transducer*
	{ LL		
range 5	{ LL	idling speed* elevated idling speed	faulty transducer
	{ LL		

These symptoms or diagnosis only apply in the case wherein the idling position switch is perceived as being intact

Because the pressure switch 28 and the potentiometer 26 are mechanically independent of one another, a sticking potentiometer slider 24 can be detected in that the return spring 36 releases the switch 28 when the driver lifts his foot from the pedal 30.

A disadvantage as compared with the embodiment of Figs. 1 and 2 is that it is not possible to arrange for the actuation or triggering of the pressure switch to take place at a transducer output voltage $U\text{-FFG}$ slightly above the idling value $U\text{-FFG-LL}$ because only a limit switch can be used to achieve the objects of the embodiment of Figs. 3 and 4.

For a complete supervision of the redundance, a special logic circuit is needed in order to identify the location of a fault unambiguously.

The circuit of Fig. 5 can be used to supervise the dynamic operation of the accelerator pedal travel transducer 16,26. This is achieved by monitoring a brake actuation signal BS to ascertain whether the brakes are applied (implying that the driver requires the idling power output) when the accelerator pedal is not in its idling position, for example, due to it being held depressed or partly depressed by a rucked mat.

To this end, a braking signal BS, which may be produced by the usual brake light switch, and the idling position signal FFG-LL, meaning the accelerator pedal is not in its idling position, are fed to an AND gate 40. The output of the AND gate 40 is fed via another AND gate 42 and a delay circuit 44 to provide a reaction signal RS1. The output of the AND gate 40 is also applied to the input T of an integrator in the form of a counter 46 whose output Q is connected to a second

-13-

input of the AND gate 42. The signal U-FFG from the accelerator pedal travel transducer is fed to the input of a differentiator 48 whose output is applied via a rectifier gate 50 to the reset input R of the counter 46.

Fig. 6 is a graph in which injected fuel quantity Q is plotted against time and shows the operation of the circuit of Fig. 5 in the case of a diesel engine. It is assumed that the EMS is operative to deliver the injected fuel quantity Q_i desired by the driver, which quantity is larger than the precautionary quantity Q_s described below. At instant T_1 , it is assumed that the driver lifts his foot from the accelerator pedal and applies the brake but that the accelerator pedal sticks in a depressed condition. The instant T_1 is thus the onset of a fault condition. The brake signal BS is passed by the AND gate 40 because the "inverted" idling position signal FFG-LL is still applied to the other input of this AND gate and reaches the delay circuit 44. After a pre-programmable delay of, say, 2 seconds a reaction signal RS1 is produced at instant T_2 and is processed by the EMS, whereby the injected fuel quantity Q is reduced to a pre-programmed precautionary value Q_s which is considered to be safe and to enable the vehicle to keep moving. According to an alternative function, the fuel quantity is reduced if the engine speed is above a value which is considered to be safe and the idling speed is controlled to this value.

The effect of the counter 46 is to cause the injected fuel quantity to decrease in a ramp-like manner so that the precautionary injected quantity Q_s is not reached until instant T_3 . The purpose of this ramp is to prevent the driver being startled by a sudden reduction in injected fuel quantity.

-14-

If the driver again depresses the accelerator pedal beyond its stuck position at the instant T_4 with the intention to increase the injected fuel quantity, the differentiator 48 supplies a signal to the reset input R of the counter 46. The latter causes the injected fuel quantity to rise again in a pre-programmable ramp-like manner, whereby the injected quantity returns to the value Q_i intended by the driver only at the instant T_5 .

The rectifier gate 50 prevents the safety conditions being removed in the event that the accelerator pedal releases itself, e.g., upon removal of the rucked footmat, whereby the injected fuel quantity cannot be increased above its precautionary value Q_s until the driver again depresses the accelerator pedal.

It is irksome for the driver to have to drive no faster than the relatively low speed achievable with the above-mentioned precautionary injected fuel quantity Q_s which corresponds to a quantity only slightly above the idling quantity. This disadvantage can be avoided by using two redundant signals, as shown in Fig. 7, whereby two faults must occur in the supervisory circuits before the driving conditions are adversely effected. The circuit shown in Fig. 7 employs the pressure switch (28) of Fig. 3, which is mechanically actuated by the potentiometer slider 24 of Fig. 1 and also the idling switch 18 of Fig. 1.

As described with reference to Fig. 6, the effect of a fault in the idling switch 18 or in the pressure switch 28 is to cause the injected fuel quantity to be reduced to a relatively low safe value Q_s in a ramp-like manner. The circuits shown in Figs. 8 and 9 are designed to enable the engine to return to normal operation in the event of detection of a fault in the pressure switch 28.

-15-

The circuit of Fig. 8 is designed to produce a reaction signal RS2 if the pressure switch 28 of Fig. 7 should fail to return to its no-load position. Should the signal BS from the brake light switch, the signal LGS-LL from the idling switch 18 and a signal from a comparator 60 which compares the transducer output U-FFG with a voltage U-FFG-MIN corresponding to a speed slightly above idling, all indicate that the driver is braking, that the output of the pedal travel transducer 26 corresponds to the idling position and that the pedal travel transducer is actually in its idling position, and should the signal PDS-LL from the pressure switch 28 suggest that the pedal is depressed, and AND gate 62 delivers an output to an integrator 64. After an adjustable total delay of 5 sec to 2 min obtained by means of the integrator 64, the reaction signal RS2 is produced and causes the main computer 12 to disregard the signal from the pressure switch 28. At the same time, the driver is warned of the faulty switch. Should the fault be removed, e.g. by re-positioning a rucked footmat, the idling position signal PDS-LL from the pressure switch 28 re-sets the integrator 64.

The circuit of Fig. 9 is designed to produce a reaction signal R3 should the pressure switch 28 indicate a no-load position even when the accelerator pedal 30 is depressed towards its full load position. A comparator 66 compares the transducer output U-FFG with a reference voltage UR to produce a signal when the pedal travel transducer 26 indicates a pedal position of at least, say, 50% of full load. Should the signal PDS-LL from the pressure switch 28 suggest that the pedal 30 is in its no-load position, an AND gate 68 delivers a signal to a counter 70. Should there be several, say two, occasions when this contradiction occurs, the

-16-

counter 70 delivers a reaction signal RS3 which is used by the computer 12 to cause the injected fuel quantity to rise from the precautionary value Q_s , to which it will have previously been set as described with reference to Figs. 5 and 6, to its intended value Q_i in a ramp-like manner. At the same time, the driver is warned of the defective pressure switch. Should the defect be removed, a signal PDS-LL indicative that the pressure switch is not in its no-load position resets the counter 70.

Instead of or in addition to the output of the comparator 66, the signal LGS-LL, indicating that the pedal travel transducer 26 is not in its no-load or idling position, can be fed to the AND gate 66, as indicated by a dotted line.

The function of the circuits of Figs. 8 and 9 is to indicate that the pressure switch 28 of Fig. 7 is intact by means of agreement between the pedal travel transducer voltage, the idling switch and the pressure switch over one plausibility phase above no-load and in no-load. Fig. 10 is a graph and Table 3 is a plausibility diagram, representing operation of the supervisory system of Fig. 7. Table 4 is a plausibility diagram showing optional modifications which can be made for range 1 or range 5.

TABLE 3

actual transducer output voltage (U-FFG)	idling switch	pressure switch	processed value or symptom	diagnosis
range 1	X	X	elevated idling speed	faulty transducer
	$\overline{\text{LL}}$	LL	U-FFG	-
	LL	$\overline{\text{LL}}$	U-FFG	-
range 2	$\overline{\text{LL}}$	LL	elevated idling speed	faulty idling switch
	$\overline{\text{LL}}$	$\overline{\text{LL}}$	elevated idling speed	faulty transducer
	$\overline{\text{LL}}$	LL	elevated idling speed	faulty pressure switch
range 3	LL	$\overline{\text{LL}}$	U-FFG	-
	LL	LL	elevated idling speed	faulty pressure switch
	$\overline{\text{LL}}$	LL	U-FFG	-
	$\overline{\text{LL}}$	$\overline{\text{LL}}$	elevated idling speed	faulty transducer
range 4	LL	$\overline{\text{LL}}$	U-FFG; limited fuel quantity	faulty idling switch
	LL	LL	elevated idling speed	faulty pressure switch
	$\overline{\text{LL}}$	$\overline{\text{LL}}$	U-FFG	-
range 5	X	X	elevated idling speed	faulty transducer

TABLE 4

actual transducer output voltage (U-FFG)	idling switch	pressure switch	processed value or symptom	diagnosis
range 1	\overline{LL}	LL	normal idling speed	-
	LL	LL	elevated idling speed	faulty transducer
range 2	\overline{LL}	LL	U-FFG	-
	LL	\overline{LL}	U-FFG	-
	\overline{LL}	LL	elevated idling speed	faulty idling switch
	LL	\overline{LL}	elevated idling speed	faulty transducer
range 3	\overline{LL}	LL	elevated idling speed	faulty pressure switch
	LL	\overline{LL}	U-FFG	-
	\overline{LL}	LL	elevated idling speed	faulty pressure switch
	LL	\overline{LL}	U-FFG	-
range 4	\overline{LL}	LL	elevated idling speed	faulty transducer
	LL	\overline{LL}	U-FFG; limited fuel quantity	faulty idling switch
	\overline{LL}	LL	elevated idling speed	faulty pressure switch
	LL	\overline{LL}	U-FFG	-
range 5	\overline{LL}	LL	normal idling speed	faulty transducer
	LL	LL	elevated idling speed	faulty transducer

4 3 2 1

-19-

In the event of a defect in the pressure switch being diagnosed, the signal from the pressure switch is ignored. In the event of a further defect, the injected fuel quantity is limited to the precautionary value.

- 20-

CLAIMS

1. Supervisory system for monitoring the accelerator pedal travel transducer (28) in an electronic control system for a combustion engine, having an idling switch (26) which detects the idling position of the accelerator pedal, characterised in that the idling switch is a pressure switch (28) actuated by take up of a lost motion travel of the accelerator pedal from its idling stop before the pedal travel transducer (16, 26) is itself displaced from its idling position.

2. Supervisory system according to claim 1, characterised in that operation of the accelerator pedal through said lost motion travel is executed against a relatively light spring force from a stop position to an idling position at which the pedal travel transducer begins to respond.

3. Supervisory system according to claim 1 or 2, characterised in that no fault in the pedal travel transducer (26) is diagnosed over tolerance ranges of triggering of the pressure switch (28) and the output signal (U-FFG) of the travel transducer (26), in that no fault signal is obtained over the cumulative transducer output range (U-FFG-MIN to U-FFG-LL0) corresponding to these tolerance ranges whether the pressure switch (28) is open or closed.

4. Supervisory system according to claim 1, 2 or 3, characterised by an additional idling switch (18) which is mechanically coupled to or associated with the pedal travel transducer (26), the actual output signal (U-FFG) from the pedal travel transducer (26) being interpreted and compared with an output signal to be expected when the pedal travel transducer (26) is at or close to the idling position and a fault indication is produced when the result of such comparison contradicts

-21-

the transducer position information (LGS) derived from the idling switch (18) and/or the pedal position information (PDS) obtained from the pressure switch (28).

5. Supervisory system according to claim 4 characterised in that a reaction signal (RS2) is produced when the signal (PDS-LL) from the pressure switch indicates that the accelerator pedal is not in its idling position, whereas at least two other signals (BS, LGS-LL, U-FFG) indicate that the accelerator pedal is in or close to its idling position, and this reaction signal (RS2) is used to cause the signal (LGS-LL) from the pressure switch to be disregarded when determining whether there is a fault on the pedal travel transducer (16).

6. Supervisory system according to claim 5, characterised in that a brake pressure signal (BS), indicative that the brakes are applied, is used to indicate that the accelerator pedal is or ought to be in its idling position.

7. Supervisory system according to claim 5 or 6, characterised by an integrator (64) for delaying production of the reaction signal (RS2) by a, preferably adjustable, period.

8. Supervisory system according to any of claims 4 to 7, characterised in that a reaction signal (RS3) is produced when the signal (PDS-LL) from the pressure switch indicates that the accelerator pedal is released, whereas at least one other signal (U-FFG, LGS-LL) indicates that the accelerator pedal is in a part or full load position, and this reaction signal (RS3) is used to cause the signal (LGS-LL) from the pressure switch to be disregarded when determining whether there is a fault on the pedal travel transducer (16).

-22-

9. Supervisory system according to claim 8, characterised by a counter (70) for counting instances of contradiction between the pressure switch signal (PDS-LL) and the other signal or signals (U-FFG, LGS-LL) to postpone production of the reaction signal (RS3) until there have been several, preferably two, such instances.

10. Supervisory system according to any preceding claim, characterised in that the idling and/or pressure switch (18, 28) is closed in the idling position of the accelerator pedal or of the pedal travel transducer.

11. Supervisory system for monitoring the accelerator pedal travel transducer (16, 26) in an electronic control system for a combustion engine, having an idling switch (18, 28) which detects the idling position of the accelerator pedal, in which the actual output signal (U-FFG) from the pedal travel transducer (16, 26) is interpreted and is compared with an output signal to be expected when the accelerator pedal is at or close to the idling position and a fault indication is produced when the information obtained from such comparison contradicts the pedal position information derived from the idling switch (18, 28), characterised in that the idling switch (16, 26) is closed in the idling position of the accelerator pedal or of the pedal travel transducer.

12. Supervisory system according to claim 10 or 11, characterised in that the idling switch (18) is arranged to be triggered from one state to the other at a position (between FFG-LL0 and FFG-LLU) at which the output signal U-FFG of the pedal travel transducer (16, 26) is relatively close to the value U-FFG-MIN obtained when the pedal is against its idling stop.

13. Supervisory system according to claim 12,

-23-

characterised in that no fault in the pedal travel transducer (18, 28) is diagnosed over a tolerance range of triggering of the idling switch (16) in that no fault signal is obtained over the transducer output range (U-FFG-LL0 to U-FFG-LLU) corresponding to this tolerance range, whether the idling switch (16) is open or closed.

14. Supervisory system according to claim 13, characterised in that a fault signal is obtained when the pedal travel transducer output (U-FFG) is at a value below the lower tolerance range value (U-FFG-LLU) and simultaneously the idling switch output signal (LGS) indicates that the accelerator pedal is not in its idling position.

15. Supervisory system according to any of claims 10 to 14, characterised in that the idling switch (18) is integrated into the pedal travel transducer (16).

16. Supervisory system according to any preceding claim, characterised in that a fault signal is obtained when the output U-FFG of the pedal travel transducer is below a lower value (U-FFG-MIN) irrespective of the position of the idling and/or pressure switch.

17. Supervisory system according to any preceding claim, characterised in that a fault signal is obtained when the output (U-FFG) of the pedal travel transducer is above an upper value (U-FFG-MAX), irrespective of the position of the idling and/or pressure switch.

18. Supervisory system according to any preceding claim, characterised in that the outputs (FFG-LL, BS) of the idling and/or pressure switch (18, 28) and a brake switch responsive to actuation of the vehicle brakes are compared to produce a reaction signal (RS1) if the accelerator pedal, or at least the accelerator pedal travel transducer is remote from its idling position when the brakes are actuated.

-24-

19. Supervisory system for the accelerator pedal travel transducer in an electronic control system for a combustion engine installed in a vehicle, having an idling switch which detects the idling position of the accelerator pedal and a brake switch responsive to actuation of the vehicle brakes, characterized in that the outputs (BS, FFG-LL) of the two switches are compared to produce a reaction signal (RS) if the accelerator pedal or at least the accelerator pedal travel transducer is remote from its idling position when the brakes are actuated.

20. Supervisory system according to claim 18 or 19, characterised in that the electronic engine control so responds to the reaction signal (RS1) that the engine power is thereby reduced to a predetermined safe value Q_s .

21. Supervisory system according to claim 18 or 19, characterised in that the electronic engine control so responds to the reaction signal (RS1) that the engine power is thereby reduced, if the engine speed is above a safe value and the engine speed is controlled down to this safe value.

22. Supervisory system according to claim 20, or 21, characterised in that the electronic engine control only responds to the reaction signal (RS1) after a delay time.

23. Supervisory system according to claim 20, 21 or 22, characterised in that the engine power is gradually reduced by the electronic engine control in response to the reaction signal (RS1).

24. Supervisory system according to claim 20, 21, 22 or 23, characterised in that the reaction signal (RS1) is discontinued in response to a change in the output (U-FFG) of the accelerator pedal travel

transducer.

25. Supervisory system according to claim 24, characterised in that the reaction signal (RS1) is discontinued only in response to an increase in the transducer output (U-FFG) but not in response to a decrease.

26. Supervisory system according to claim 24 or 25, characterised in that the engine power is gradually increased by the electronic engine control following discontinuance of the reaction signal (RS1).

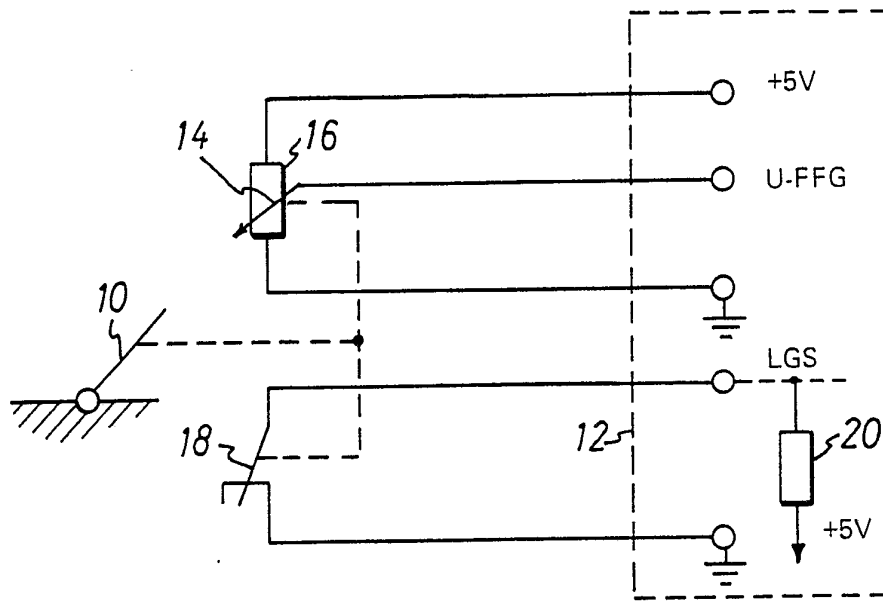

Fig 1.

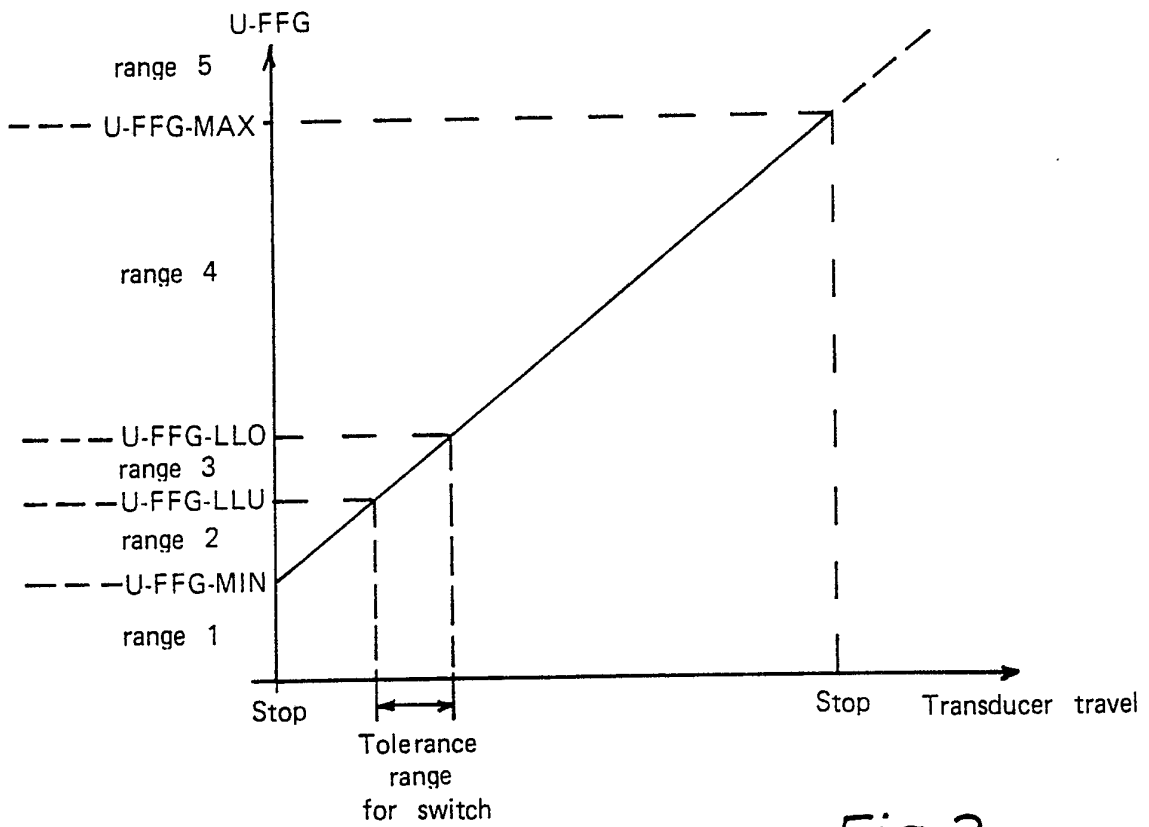

Fig 2.

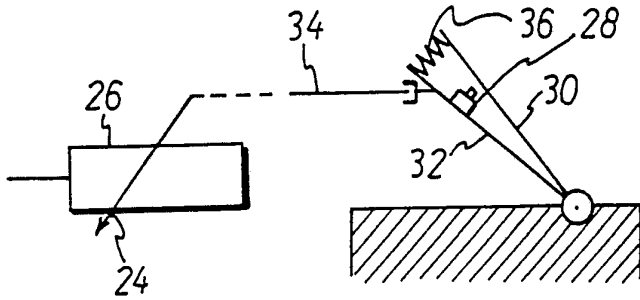

Fig 3

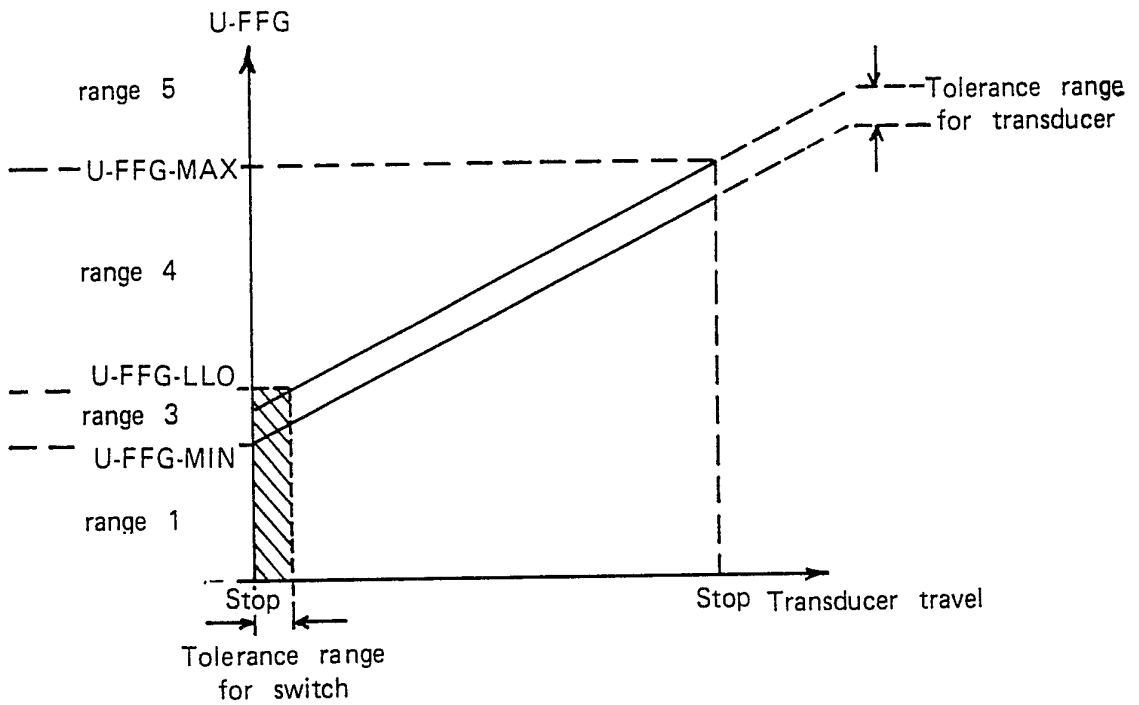

Fig 4

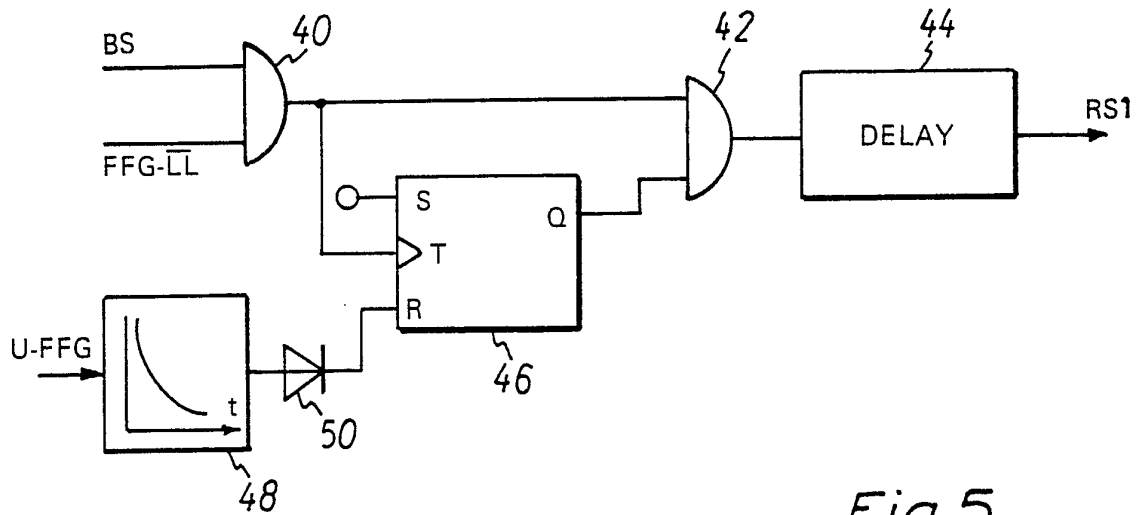

Fig 5.

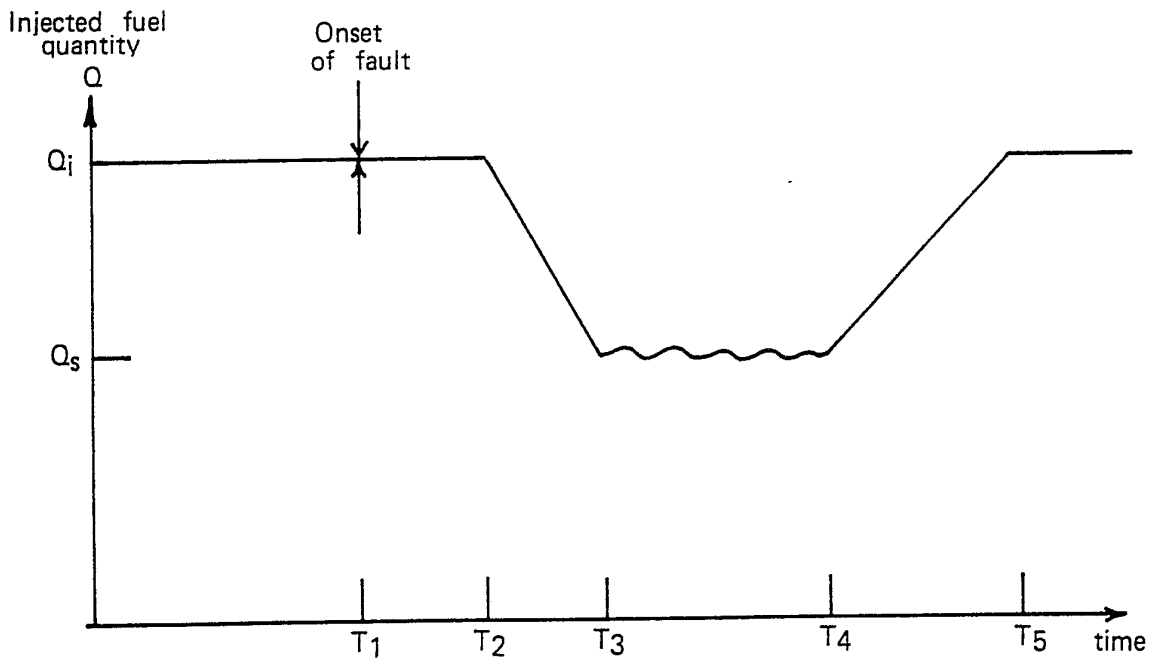

Fig 6.

4/5

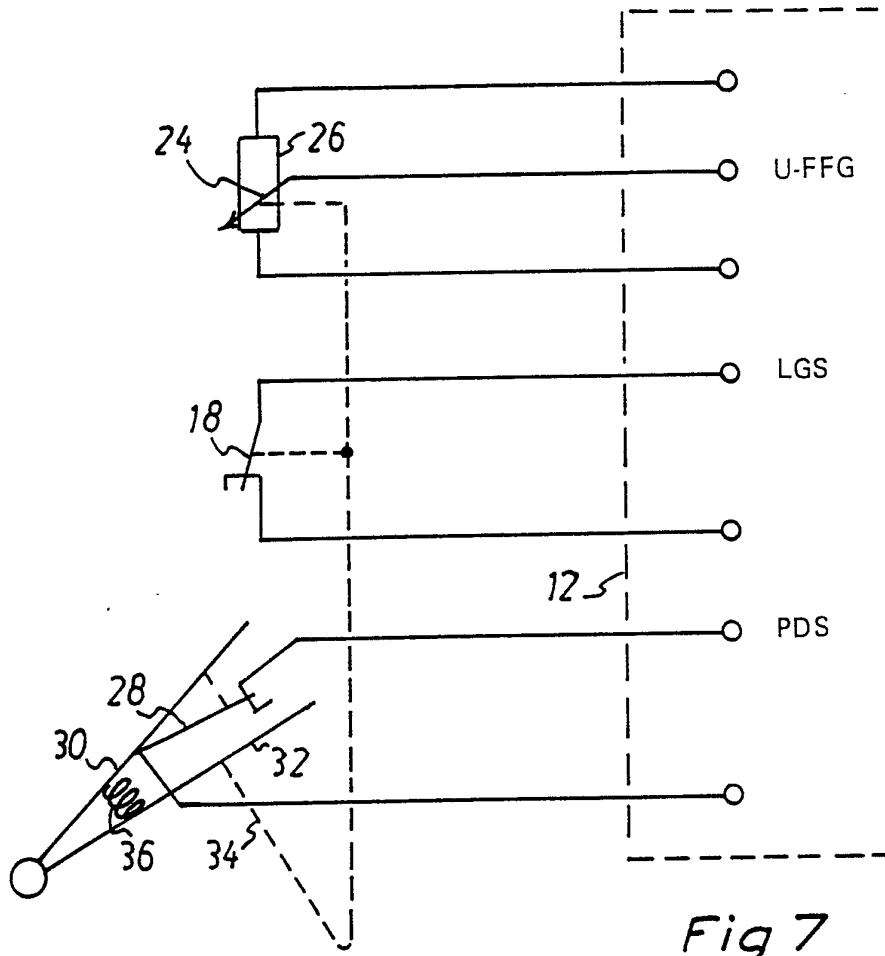

Fig 7.

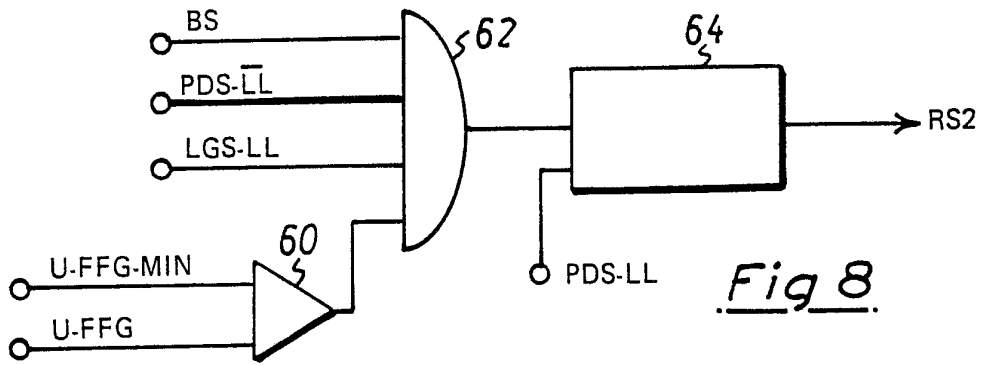

Fig 8.

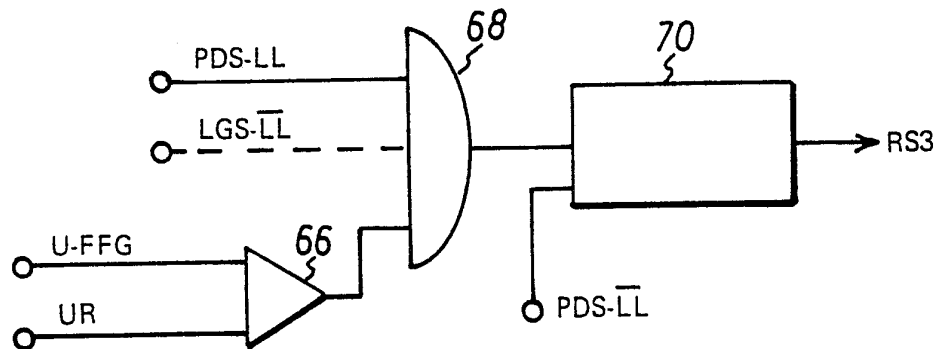

Fig 9.

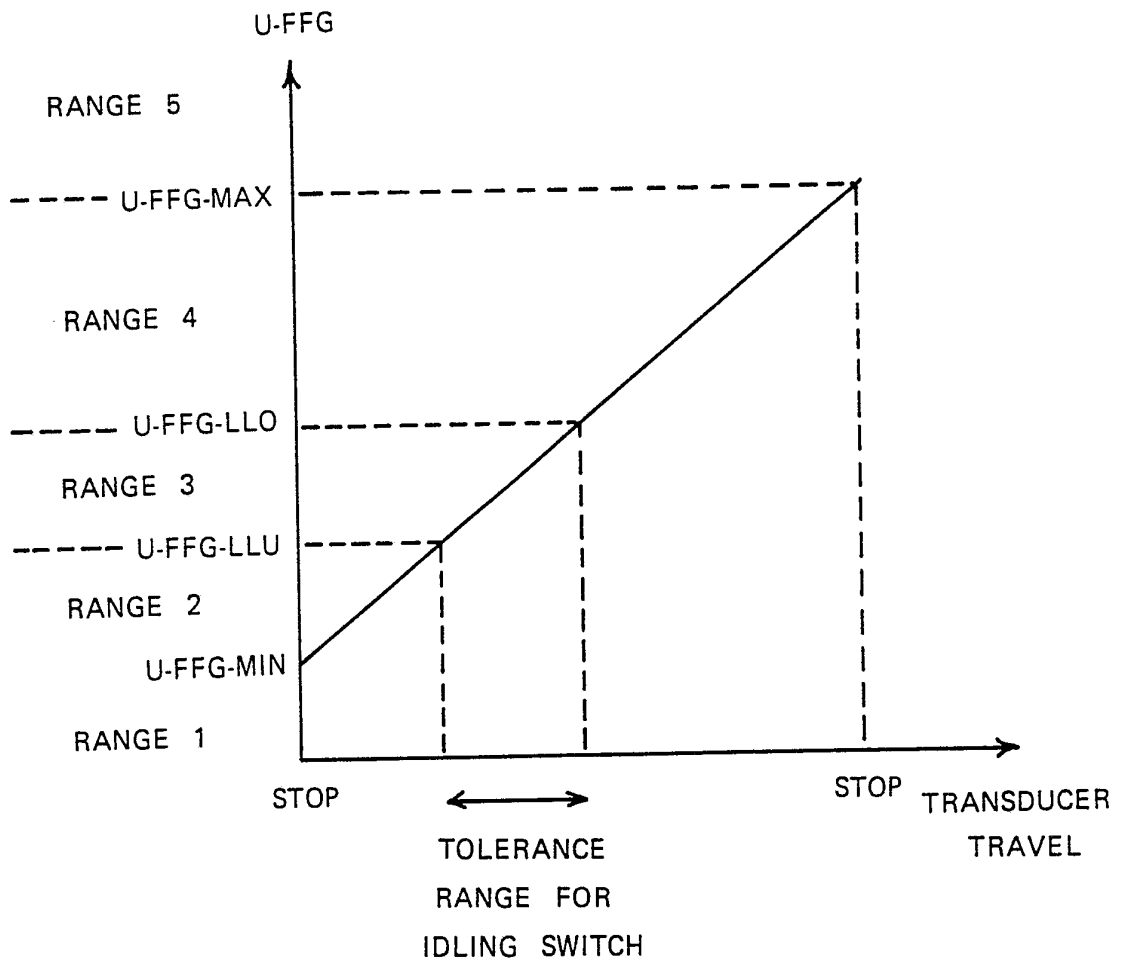
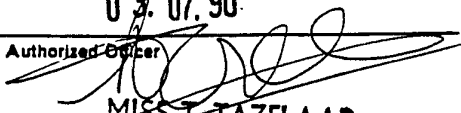

Fig 10.

INTERNATIONAL SEARCH REPORT

International Application No **PCT/EP 89/01099**

I. CLASSIFICATION OF SUBJECT MATTER (if several classification symbols apply, indicate all) ⁶		
According to International Patent Classification (IPC) or to both National Classification and IPC		
IPC ⁵ : F 02 D 11/10, F 02 D 41/22, B 60 Q 1/44		
II. FIELDS SEARCHED		
Minimum Documentation Searched ⁷		
Classification System	Classification Symbols	
IPC ⁵	F 02 D, G 06 K, B 60 K, B 60 Q	
Documentation Searched other than Minimum Documentation to the Extent that such Documents are Included in the Fields Searched ⁸		
III. DOCUMENTS CONSIDERED TO BE RELEVANT ⁹		
Category ⁹	Citation of Document, ¹¹ with indication, where appropriate, of the relevant passages ¹²	Relevant to Claim No. ¹³
X	EP, A, 0269118 (NIPPONDENSO CO., LTD) 1 June 1988 see page 7, lines 1-9; page 8, line 1 - page 9, line 8; page 13, line 54 - page 14, line 1; figures	1,2,8,10- 12
Y	--	16,17,24- 26,6,15, 18-20,22, 23
X	US, A, 4505357 (PFALZGRAF et al.) 19 March 1985 see column 2, line 19 - column 3, line 23; figure	1,2,4
X	US, A, 2824921 (W.M. BAUMHECKEL) 25 February 1958 see the whole document	1,2
<p>¹⁰ Special categories of cited documents:</p> <p>"A" document defining the general state of the art which is not considered to be of particular relevance</p> <p>"E" earlier document but published on or after the international filing date</p> <p>"L" document which may throw doubts on priority claim(s) or which is cited to establish the publication date of another citation or other special reason (as specified)</p> <p>"O" document referring to an oral disclosure, use, exhibition or other means</p> <p>"P" document published prior to the international filing date but later than the priority date claimed</p> <p>"T" later document published after the international filing date or priority date and not in conflict with the application but cited to understand the principle or theory underlying the invention</p> <p>"X" document of particular relevance; the claimed invention cannot be considered novel or cannot be considered to involve an inventive step</p> <p>"Y" document of particular relevance; the claimed invention cannot be considered to involve an inventive step when the document is combined with one or more other such documents, such combination being obvious to a person skilled in the art.</p> <p>"&" document member of the same patent family</p>		
IV. CERTIFICATION		
Date of the Actual Completion of the International Search	Date of Mailing of this International Search Report	
24th May 1990	03.07.90	
International Searching Authority	Signature of Authorized Officer	
EUROPEAN PATENT OFFICE	 MISS TAZELAAR	

III. DOCUMENTS CONSIDERED TO BE RELEVANT (CONTINUED FROM THE SECOND SHEET)		
Category *	Citation of Document, ** with indication, where appropriate, of the relevant passages	Relevant to Claim No.
Y	DE, A, 3531198 (ROBERT BOSCH GmbH) 12 March 1987 see column 7, line 48 - line 57; column 8, line 64 - column 9, line 17; column 11, line 34 - column 12, line 15; column 14, line 46 - column 16, line 12; figures (cited in the application)	6,15,18-20, 22,23
	--	
A	Patent Abstracts of Japan, vol. 10, no. 153 (M-484)(2209), 3 June 1986; & JP, A, 618442 (NISSAN JIDOSHA K.K.) 16 January 1986	6,18,19
	--	
A	Patent Abstracts of Japan, vol. 9, no. 316 (M-438)(2039), 12 December 1985, & JP, A, 60150453 (TOYOTA JIDOSHA K.K.) 8 August 1985	1,24-26
	--	
A	DE, A, 3301742 (ROBERT BOSCH GmbH) 26 July 1984 see page 8, line 14 - page 10, line 2; page 12, lines 1-13; figures (Cited in the application)	4,6

**ANNEX TO THE INTERNATIONAL SEARCH REPORT
ON INTERNATIONAL PATENT APPLICATION NO.**

EP 8901099
SA 31103

This annex lists the patent family members relating to the patent documents cited in the above-mentioned international search report. The members are as contained in the European Patent Office EDP file on 26/06/90. The European Patent Office is in no way liable for these particulars which are merely given for the purpose of information.

Patent document cited in search report	Publication date	Patent family member(s)	Publication date
EP-A- 0269118	01-06-88	JP-A- 63138133	10-06-88
		JP-A- 63138132	10-06-88
		JP-A- 63147945	20-06-88
		JP-A- 63147948	20-06-88
		JP-A- 63150450	23-06-88
		US-A- 4854283	08-08-89
US-A- 4505357	19-03-85	DE-A- 3238218	19-04-84
		EP-A, B 0106011	25-04-84
US-A- 2824921		None	
DE-A- 3531198	12-03-87	EP-A, B 0213349	11-03-87
		EP-A- 0350082	10-01-90
		JP-A- 62051737	06-03-87
		US-A- 4791900	20-12-88
DE-A- 3301742	26-07-84	GB-A, B 2133906	01-08-84
		JP-A- 59134339	02-08-84
		US-A- 4515125	07-05-85

EPO FORM P0479

For more details about this annex : see Official Journal of the European Patent Office, No. 12/82