



(11) (21) (C) **2,152,647**  
(22) 1995/06/26  
(43) 1995/12/28  
(45) 2000/10/31

(72) Turnlund, Todd Hanson, US

(72) Eury, Robert Paul, US

(73) ADVANCED CARDIOVASCULAR SYSTEMS, INC., US

(51) Int.Cl.<sup>6</sup> A61F 2/06

(30) 1994/06/27 (08/266,964) US

(54) **EXTENSEUR EN MAILLES FIXEES SUR SUPPORT  
PELLICULAIRE**

(54) **BIODEGRADABLE MESH AND FILM STENT**

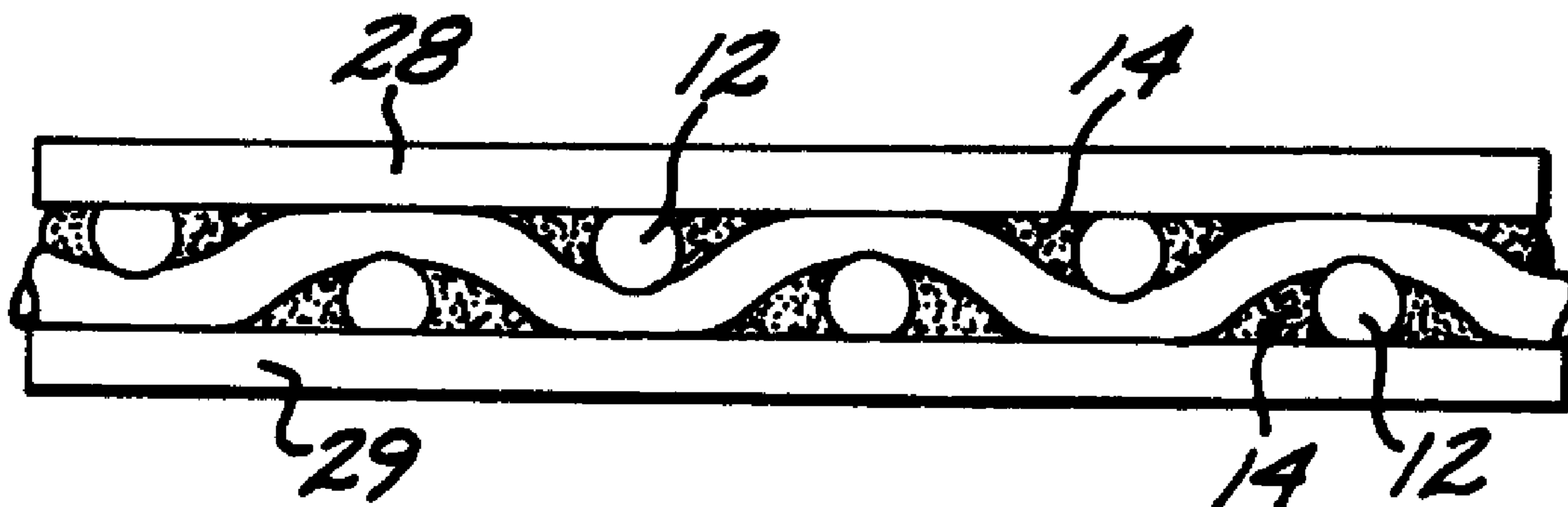

(57) A biodegradable mesh-and-film stent for use in blood vessels is formed of a sheet of a composite mesh material formed of biodegradable high-strength polymer fibers bonded together with a second biodegradable adhesive polymer, and laminated on at least one side with a thin film of a third biodegradable polymer. The biodegradable mesh-and film material is formed as a sheet and cut in a shape that can be used as a stent, such as a "belt-buckle" type shape, the ends of which can be joined in a contractible, expandable loop. In the method of making the biodegradable composite mesh-and-film stent, the composite mesh preferably is formed from a weave formed of high-strength biodegradable polymeric fibers, and a plurality of low-temperature melting biodegradable polymeric fibers. In an alternate embodiment, the high strength fibers are co-mingled with the low-temperature melting fibers. In another alternate embodiment, the high-strength fibers are coated with the low-temperature melting polymer. The composite mesh is covered on at least one side by a laminating film, and then is cut into the shape of the stent.



BIODEGRADABLE MESH-AND-FILM STENTABSTRACT OF THE DISCLOSURE

A biodegradable mesh-and-film stent for use in blood vessels is formed of a sheet of a composite mesh material formed of biodegradable high-strength polymer fibers bonded together with a second biodegradable adhesive polymer, and laminated on at least one side with a thin film of a third biodegradable polymer. The biodegradable mesh-and-film material is formed as a sheet and cut in a shape that can be used as a stent, such as a "belt-buckle" type shape, the ends of which can be joined in a contractible, expandable loop. In the method of making the biodegradable composite mesh-and-film stent, the composite mesh preferably is formed from a weave formed of high-strength biodegradable polymeric fibers, and a plurality of low-temperature melting biodegradable polymeric fibers. In an alternate embodiment, the high strength fibers are co-mingled with the low-temperature melting fibers. In another alternate embodiment, the high-strength fibers are coated with the low-temperature melting polymer. The composite mesh is covered on at least one side by a laminating film, and then is cut into the shape of the stent.

BIODEGRADABLE MESH-AND-FILM STENTBACKGROUND OF THE INVENTION5 Field of the Invention

10 This invention relates generally to expandable intraluminal vascular grafts, generally referred to as stents, and more particularly concerns biodegradable mesh stents reinforced with a biodegradable film laminate capable of releasing therapeutic drugs.

Description of Related Art

15 Stents used to maintain patency of vessels in the body typically are implanted within a vessel in a contracted state, and once in place at the site at the site in the vessel at which treatment is to be rendered are expanded to allow fluid flow through the vessel and the stent. Such a stent can be moved along a guide wire previously positioned in the vessel, and then expanded by inflation of a balloon about which the stent is disposed. Deflation of the balloon and removal of the guide wire leaves the stent in place in the vessel, locked in an expanded state. It has been found that continued exposure of the stent to blood can lead to undesirable thrombus formation, and the presence of a stent in a blood vessel over time can cause the blood vessel wall to weaken, which creates the potential for an arterial rupture or the formation of aneurisms. The stent also can become covered by endothelial tissue after implantation of the stent, after which the usefulness of the stent may be substantially diminished, and the continued presence of the stent may cause a variety of problems or complications.

35 Therefore, it is desirable that the material of the stent be biodegradable, or bioabsorbable, to reduce the risk of thrombosis or injury to the blood vessel. It also is desirable that the stent be formed of material

having minimal thickness, so as to reduce the potential for blockage of blood flow and to facilitate biodegradability or bioabsorption. However, the material must have sufficient radial strength to function as a stent, so it is desirable to reinforce the stent, preferably with a material that also is biodegradable or bioabsorbable material.

It often also is useful to provide localized pharmacological treatment of a blood vessel at the location at which the stent is deployed. Therefore, it would be desirable to form a stent of materials that are capable both of absorbing therapeutic drugs and of releasing the drugs in a blood vessel at a predictable rate, for an ascertainable period of time, which materials also are biodegradable or bioabsorbable, and which can provide sufficient radial strength to maintain patency of a blood vessel.

Biodegradable fibers have been used in forming bone fixation plates. In using such fibers to form a biodegradable stent, the fibers can be formed as a mesh, which mesh typically does not alone lend sufficient strength to the stent to maintain patency of a blood vessel, and it is possible for the fibers to move around and separate. Chemical sizing to strengthen the elements can degrade the elements and solvent lamination of the fibers to imbue strength can leave an undesirable residue of solvent. It would be desirable to strengthen the mesh of fibers and to prevent the fibers of the mesh from separating and moving around, by laminating the mesh with a film of biodegradable, bioabsorbable material. In order to provide sufficient radial strength to the stent, it has been found that fiber weave in the mesh should be dense and closely packed. However, too dense a packing of fibers can prevent sufficient penetration of the film laminate into the fiber mesh, compromising optimum bonding of a film to the fibers of the mesh. Accordingly, lamination of such a high density fibrous

mesh typically is difficult to achieve, and such attempts often lend to inconsistent results. It would be desirable to provide a stent made of a mesh of biodegradable or bioabsorbable fibers that can be  
5 closely-packed for strength, and further which are reinforced with a biodegradable film lamination. The present invention meets these needs.

#### SUMMARY OF THE INVENTION

10

Briefly, and in general terms, the present invention provides a biodegradable and/or bioabsorbable mesh-and-film-laminate stent, and method of manufacture for the same, which provides for good bonding of a  
15 laminating film to a fibrous mesh layer of the stent by incorporating a biodegradable, low-temperature melting, polymeric adhesive material into a composite biodegradable fiber mesh, before the composite mesh is laminated to a thin film of biodegradable material. The  
20 thin, biodegradable film strengthens the composite mesh of biodegradable material without significantly increasing the thickness of the composite mesh, and the stent of the invention is easily manufacturable from the composite mesh-and-film-laminate of the invention. The  
25 stent is both entirely biodegradable and bioabsorbable and further is capable of delivering therapeutic drugs locally within a vessel. The multi-layered laminated construction of the stent allows for selection of one or more layers of resorbable material which layers are  
30 capable of retaining selected drugs and releasing them within the affected blood vessel upon implantation.

The laminated construction of the stent also allows a plurality of different drug-containing materials to be combined in a single stent. Depending upon the  
35 construction and lamination of the stent, drugs can be released simultaneously or sequentially, from the

-5-

exterior surface of the stent to a vessel wall, or directly into the bloodstream, as desired.

Accordingly, the invention provides a biodegradable laminated fibrous mesh, comprising:

5                   a mesh layer having first and second sides, said mesh layer being formed from a plurality of fibers of a first biodegradable polymer and from a second biodegradable adhesive polymer characterized by a lower melting temperature than the melting temperature of said  
10 first biodegradable polymer, the first biodegradable polymer and the second biodegradable adhesive polymer being heat bonded together; and

                  at least one layer of a film of a biodegradable polymer bonded to said mesh layer on at least one side of  
15 said mesh layer to form a sheet of biodegradable mesh and film material.

The biodegradable mesh-and-film-laminate preferably is formed as a sheet which then is cut into a shape that can be used as a stent, such as a "belt-buckle" type  
20 shape that can be joined in a contractible and expandable loop. the stent preferably is cut in such a shape from the sheet of biodegradable mesh-and-film laminate to have first and second ends, and a main body portion between the first and second ends. The first end preferably  
25 includes a slot for receipt of the second end, so that the second end and main body portion are insertable through the slot so as to form a cylindrical loop. The second end includes means for retaining the second end inserted in the slot, and the main body portion includes  
30 means for releasably engaging the slot to adjustably retain the main body portion in the slot, so that the stent can be placed in a vessel in a contracted cylindrical loop, urged into an expanded configuration, by suitable means such as by an inflation balloon, and  
35 locked in the expanded configuration by the means for releasably engaging the slot.

In one preferred embodiment, a biodegradable,

5a

laminated, fibrous composite mesh material is formed of a plurality of fibers of a first biodegradable polymer, bonded together with a plurality of a second  
5 biodegradable adhesive polymer fibers having a melting

point below that of the first biodegradable polymer. The fibers of the first biodegradable polymer preferably are made of a biodegradable, bioabsorbable, high-modulus material, such as polyglycolic acid (PGA), although other  
5 high-modulus polymeric fibers, such as fibers of poly-L-lactic acid (L-PLA), polyorthoesters, polyanhydrides, polyiminocarbonates, and inorganic calcium phosphate also may be suitable. The material selected for the mesh layer of the present invention must be biodegradable and  
10 bioabsorbable, while at the same time providing the necessary physical support structure for the construction of the stent. Further, it is desirable to use a material that will provide a degree of longitudinal flexibility, in order to facilitate transportation of the stent to the  
15 intended implantation site in a vessel. These requirements can be met by polymers such as PGA or L-PLA which have been extruded and oriented to realize maximum tensile strength and optimal flexural properties.

The fibers of the second biodegradable adhesive  
20 polymer preferably are selected to have a melting point below the melting point of the first biodegradable polymer, to provide an adhesive bonding, during lamination, between the fibers of the first biodegradable polymer of the mesh and the outer film layers. The  
25 fibers of the second biodegradable adhesive polymer preferably are made of polycaprolactone (PCL), poly-DL-lactic acid (DL-PLA), or a combination of L-PLA and PCL. The fibers of the second biodegradable polymer also can be made of other suitable polymers, such as  
30 polyorthoesters, aliphatic polycarbonates, and polyphosphazenes. In one preferred embodiment, the composite mesh can have a weave density of at least about 13 fibers per centimeter (about 50 fibers per inch), and can be woven in a plain weave pattern of pairs of the  
35 first fiber and fibers of the second polymer.

The composite mesh preferably is laminated by heat and pressure on at least one side with a thin film

of a biodegradable polymer, which is capable of being absorbed by the body, to reinforce the mesh layer, and which can retain sufficient quantities of particular drugs, and that can release those drugs at a predictable rate when the biodegradable mesh-and-film stent is implanted in a vessel. The thin film with which the mesh is laminated preferably is a biodegradable polymer selected from the group consisting of DL-PLA and L-PLA, or is a combination thereof. Such polymers first are intermixed with the drug or drugs to be delivered, and then either are extruded or solvent-cast. The drug-containing layer or layers and the mesh layer preferably subsequently are laminated to one another by heat-fusion lamination, thereby simultaneously melting the second biodegradable polymer in the mesh and bonding the mesh with the film laminate.

The invention also provides for a method of making a biodegradable composite mesh-and-film stent for use in blood vessels, which is formed of biodegradable polymeric fibers that are strengthened by bonding the fibers with a biodegradable adhesive polymer and which is laminated with a biodegradable polymeric film. In one preferred embodiment, the composite mesh is a weave formed from a plurality of high-strength fibers made of a first biodegradable polymer and a plurality of lower-temperature melting fibers made of a second biodegradable polymer. In an alternate embodiment, the high-strength fibers are co-mingled with the lower-temperature melting fibers. In another alternate embodiment, a plurality of the high-strength biodegradable fibers are coated with the low-temperature melting biodegradable polymer, and in a variation of this embodiment, the high-strength biodegradable fibers individually are coated with the lower-temperature melting biodegradable polymer, and are used to weave the mesh. The composite mesh is covered on at least one side by a laminating film, preferably the mesh is placed between laminating films, and is laminated

- 8 -

at an elevated temperature, to melt the lower-temperature melting biodegradable polymer to produce the biodegradable composite mesh-and-film. The laminated biodegradable mesh-and-film material then can be cut, preferably with a laser, to form the stent.

The laminated construction of the stent allows the mesh layer to be fabricated prior to lamination, and the drug-impregnated film layers to be laminated to the mesh after fabrication of the mesh is complete, thereby avoiding a deterioration or degradation of the drugs which otherwise might occur during the fabrication of the mesh.

The present invention also provides a biodegradable mesh and film stent for use in maintaining the patency of blood vessels, said stent comprising:

a mesh layer having first and second sides, formed from a plurality of fibers of a first biodegradable polymer and from a second biodegradable adhesive polymer characterized by a lower melting temperature than the melting temperature of said first biodegradable polymer, the first biodegradable polymer and the second biodegradable adhesive polymer being heat bonded together;

at least one layer of a film of a biodegradable polymer bonded to said mesh layer on at least one side of said mesh layer to form a sheet of biodegradable mesh and film material;

said sheet of biodegradable mesh and film material having first and second ends, a main body portion between said first and second ends, and means on each of said first and second ends to retain one said end in the other said end, said sheet of biodegradable mesh and film material being rolled up into a cylindrical configuration whereby said first end overlaps and is retained by said retaining means to said second end.

The present invention also provides a biodegradable mesh and film stent for use in maintaining the patency of blood vessels, said stent comprising:

- 8a -

a mesh layer having first and second sides, formed from a plurality of fibers of a first biodegradable polymer and from a second biodegradable adhesive polymer characterized by a lower melting temperature than the melting temperature of said first biodegradable polymer, the first biodegradable polymer and the second biodegradable adhesive polymer being heat bonded together;

at least one layer of a film of a biodegradable polymer bonded to said mesh layer on at least one side of said mesh layer to form a sheet of biodegradable mesh and film material;

said sheet of biodegradable mesh and film material having first and second ends and a main body portion between said first and second ends, said first end having a surface defining a slot for receiving said second end, said second end and said main body portion being insertable through said slot so as to form a loop, said second end having means for retaining said second end inserted in said slot, said main body portion having means for releasably engaging said slot to adjustably retain said main body portion in said slot.

In a further aspect, the present invention provides a method of making a biodegradable laminated fibrous mesh, comprising the steps of:

forming a mesh of a plurality of fibers of a first biodegradable polymer and a second biodegradable polymer, said second biodegradable adhesive polymer melting at a temperature lower than said first biodegradable polymer;

heating the mesh to melt the second biodegradable adhesive polymer to a temperature from about 49° to 165.5° C (120° to about 330° F); and

laminating the mesh with at least one laminating film.

In a further aspect, the present invention provides a method of making a biodegradable mesh and film stent

- 8b -

for use in maintaining the patency of blood vessels,  
comprising the steps of:

5 forming a sheet of biodegradable mesh from a  
plurality of fibers of a first biodegradable polymer and  
a second biodegradable adhesive polymer, the second  
biodegradable adhesive polymer melting at a lower  
temperature than the first biodegradable polymer;

10 heating the sheet of mesh to a temperature  
above the melting point of the second biodegradable  
adhesive polymer but below that of the melting point of  
the first polymer;

placing at least one laminating film on at least one  
side of the mesh;

15 heating the laminating film and the mesh to laminate  
the film to the mesh; and

cutting the sheet of biodegradable mesh together  
with the laminating film into a shape to form a the  
stent, the stent being formed to included first and  
20 second ends, a main body portion between the first and  
second ends, and means on each of said first and second  
ends to retain one said end in the other said end;

rolling the sheet of biodegradable mesh and  
laminating film into a cylindrical configurations whereby  
25 the first end overlaps and is retained by the retaining  
means to the second end.

In a further aspect, the present invention provides  
a method of making a biodegradable mesh and film stent  
for use in maintaining the patency of blood vessels,  
30 comprising the steps of:

forming a mesh of a plurality of fibers of a  
first biodegradable polymer and a second biodegradable  
adhesive polymer, said second biodegradable adhesive  
polymer melting at a lower temperature than the first  
35 biodegradable polymer;

placing at least one laminating film on at  
least one side of said mesh;

heating said laminating film and mesh to melt  
said second biodegradable adhesive polymer and form a

- 8c -

mesh and film laminate; and

cutting the mesh and film laminate in a shape to form said stent, said stent being formed to include  
5 first and second ends and a main body portion between said first and second ends, said first end having a surface defining a slot for receiving said second end, said second end and said main body portion being formed to be insertable through said slot so as to form a loop,  
10 said second end being formed to include means for retaining said second end inserted in said slot, and said main body portion being formed to have means for releasably engaging said slot to adjustably retain said main body portion in said slot.

15 These and other aspect and advantages of the invention will become apparent from the following detailed description, and the accompanying drawings, which illustrate by way of example the features of the invention.

20 BRIEF DESCRIPTION OF THE DRAWINGS

Fig. 1 is an enlarged top plan view of a small section of a biodegradable mesh weave of high-strength and low-temperature melting fibers according to the principles of the invention;

25 Fig. 2 is an enlarged cross-sectional view of an alternate composite fiber for making the biodegradable mesh, formed of co-mingled high-strength and low-temperature melting fibers;

30 Fig. 3 is an enlarged cross-sectional view of a second alternate composite fiber for making the biodegradable mesh, formed by coating the high-strength fibers with a low-temperature melting polymer;

Fig. 4 is an enlarged cross-sectional view of a third alternate composite fiber to be used in weaving

the biodegradable mesh, formed by coating individual high-strength fibers with a low-temperature melting polymer;

5            Fig. 5 is a diagrammatic view of a laminating apparatus that can be used for laminating the mesh on one side with a biodegradable film;

10           Fig. 6 is a diagrammatic view of a lamination apparatus that can be used for laminating the mesh on two sides with a biodegradable film;

15           Fig. 7 is an enlarged cross-sectional view of a biodegradable mesh according to the principles of the invention;

20           Fig. 8 is an enlarged cross-sectional view of the biodegradable mesh-and-film laminate after melting of the lower-melting biodegradable polymer fibers of the mesh during lamination;

25           Fig. 9 is a top plan view of a biodegradable mesh-and-film stent according to the principles of the invention; and

            Fig. 10 is a perspective view of the biodegradable mesh-and-film stent of Fig. 9, joined in a loop configuration.

30            DETAILED DESCRIPTION OF THE PREFERRED EMBODIMENTS

            Continued exposure of a stent to blood can lead to undesirable thrombus formation, and the continued presence of a stent in a blood vessel can lead to a variety of problems or complications. However, forming the stent so that the stent has minimal thickness to facilitate biodegradability and bioabsorption can have

35

the effect of weakening the radial strength of the device: strength which is necessary for the stent to maintain blood vessel patency. A mesh of biodegradable fibers can form a thin material for making a stent, and  
5 can be strengthened and can prevent separation and movement of the fibers in the mesh by virtue of lamination of the mesh with a film of a biodegradable, bioabsorbable material. However, closely packing the fibers of the mesh to provide sufficient radial strength  
10 to the stent can interfere with adequate bonding of the film layers to the mesh.

Accordingly, the invention is embodied in a biodegradable mesh-and-film stent and a method of manufacturing the stent, which involves incorporating a  
15 biodegradable, low-temperature melting adhesive material into the biodegradable fiber mesh, and laminating the composite mesh on at least one side with a thin reinforcing film of biodegradable material.

As is illustrated in the drawings, in one  
20 preferred embodiment, a biodegradable laminated fibrous mesh 10 is formed from a weave of a plurality of fibers of a high-strength biodegradable polymer 12 and a plurality of fibers of a second biodegradable polymer 14 that melts at a lower temperature than at which the first  
25 biodegradable polymer will melt. As used in this description, the terms biodegradable, bioabsorbable, resorbable, degradable, and absorbable are meant to encompass materials that are broken down and gradually absorbed or eliminated by the body, whether these  
30 processes are due to hydrolysis or metabolic processes.

The mesh layer comprises the main structural component of the stent, and provides the principal physical characteristics necessary for the stent to maintain the patency of the blood vessel in which it is  
35 implanted, and the desired flexural characteristics to allow it to be moved into position and expanded. The fibers readily can be woven together in accordance with

principles known to a person skilled in the art, with reference to this description. The high-strength fibers preferably are made of a first biodegradable, bioabsorbable, high modulus polymer, such as polyglycolic acid (PGA), although other high-modulus polymeric fibers also may be suitable, such as fibers of poly-L-lactic acid (L-PLA), polyorthoesters, polyanhydrides, polyiminocarbonates, and or biodegradable inorganic fibers, such as the family of calcium phosphates. Other biodegradable, bioabsorbable polymers, such as polyorthoesters and polyanhydrides also may be suitable. In this preferred embodiment, the second fiber woven in the mesh preferably is a second biodegradable polymer fiber having a melting point below that of the first biodegradable polymer. The second, relatively lower temperature melting biodegradable polymer can be, for example, polycaprolactone (PCL), poly-DL-lactic acid (DL-PLA), or a combination of L-PLA and PCL, to provide an adhesive bonding between the first polymeric fibers of the mesh and the outer film layers during lamination. The second plurality of biodegradable adhesive polymer fibers also can be made of other suitable polymers, such as polyorthoesters, aliphatic polycarbonates, and polyphosphazenes. In one aspect of the invention, the melting point of the second biodegradable polymer can be up to about 200°C (about 392°F), although the melting point of the second biodegradable polymer can vary, depending upon the specific polymer or polymers selected as the relatively higher melting first biodegradable polymer and as the relatively lower temperature melting second biodegradable polymer. The fibers are typically about .0025 mm to about 0.051 mm (about 0.0001 in. to about 0.002 in.) in diameter. PGA fibers are typically about 5 - 7 gm/denier, while DL-PLA fibers are typically about 2 - 3 gm/denier.

In one preferred weave, as shown in Fig. 1, the composite mesh formed by the two fibers is woven in a

two-over-two plain weave pattern of pairs of the high-strength and lower-melting fibers, and preferably has a weave density of at least about 127 fibers per cm (about 50 fibers per inch). However, the weave-density can vary considerably, such as from approximately 25.4 fibers per cm (approximately 10 fibers per inch) to approximately 50.8 fibers per cm (approximately 200 fibers per inch), for example, depending upon the thickness of materials selected. Co-weaving the high-strength fibers and low-temperature melting fibers in this manner intimately mixes the fibers, eliminating the need to apply high pressures and temperatures in order to achieve good bonding during lamination, and the composite mesh of fibers can be produced in this manner with simple weaving equipment that is well known to those skilled in the art. The ratio of high-strength fibers to the lower-melting polymer fibers can be optimized with other fiber ratios as well, such as with three high-melt fibers plus one low-melt fiber, one high-melt fiber plus three low-melt fibers, two high-melt fibers plus one low-melt fiber, or one high-melt fiber plus two low-melt fibers, for example, and in different weave patterns such as three-over-one, one-over-three, two-over-one, or one-over-two weaves, and the like, to provide the desired strength and close packing of the biodegradable fibrous mesh preparatory to lamination. The mesh typically is about 0.005 mm (about 0.0002 in.) to about 0.127 mm (about 0.005 in.) thick, or can be thicker for larger stents, such as those intended for use in peripheral arteries, for example. When heated during lamination, the low-temperature-melting fibers serve as an adhesive, strengthening the mesh, due to the bonding of the higher melting, high-strength fibers and the lower-melting fibers together under heat and pressure. Alternatively, the higher-temperature melting, high-strength fibers can be co-mingled with the lower-temperature melting fibers to make a composite fiber for forming the

composite mesh, as is illustrated in Fig. 2. In another alternative embodiment, a similar composite fiber 22 can be formed for making the mesh, by coating a plurality of the higher-temperature melting, high-strength fibers 24 with the lower-temperature-melting polymer 25, as is illustrated in Fig. 3. In a variation of this embodiment, individual higher-temperature-melting, high-strength fibers 26 can be coated with the lower-temperature-melting polymer 27, to be used in weaving the biodegradable mesh, as is shown in Fig. 4.

The composite mesh 10 of the biodegradable high-strength fibers 12 and lower-melting, biodegradable polymer 14, preferably is laminated with a biodegradable polymeric film 28,29 (see Figs. 5, 6 and 8) such as DL-PLA or L-PLA. The polymeric film typically is about 0.013 mm (about 0.0005 in.) to about 0.13 mm (about 0.005 in.) thick, or can be thicker for peripheral artery applications of the stent. When laminated on two sides, the thickness of the laminated mesh can approach approximately 0.025 mm (approximately 0.001 in.) to 0.64 mm (approximately 0.025 in.) and when laminated on only one side, the thickness of the laminated mesh can approach approximately 0.018 mm (approximately 0.0007 in.) to 0.508 mm (approximately 0.020 in.), for example. The layers of biodegradable polymeric film 28 on either side of the mesh 10 are selected for the capacity of the layers to reinforce the mesh, and to absorb and release drugs at predictable rates, when the stent is implanted in a blood vessel or other lumen in the body. As is illustrated in Fig. 6, the biodegradable polymeric film layers 28, 29 are disposed so that each layer of film applied contacts the surface of the mesh. The biodegradable polymeric film layers can contain the same drugs or different drugs, or combinations of drugs. Alternatively, only one drug-releasing layer may be applied to the surface of the mesh, or additional layers of biodegradable polymeric film can be built up on top of

one another for sequential release of the drugs absorbed within each layer.

5 The dimensions of the stent, as well as the ultimate strength and physical characteristics of the stent and the particular drugs and drug-delivery rates infused in it are selected with regard to the particular application for which the stent is intended. For example, it would be desirable for stents according to the principles of the invention to be implanted in coronary arteries to release drugs that can control thrombosis from the inner layer of the stent which is exposed to the bloodstream. Appropriate drugs for this purpose include heparin and prostacyclin, and the like. The film layer to be used as the outer layer of the stent also can be provided with drugs such as angiopeptin, methotrexate, and heparin, to counteract restenosis.

10 The mesh is formed as a sheet, and typically is first cut into squares or strips of a suitable size for the lamination equipment. When the mesh is to be laminated on one side only, the mesh-and-film-laminate can be bonded by a typical two-ply fusion lamination system 32, as is illustrated in Fig. 5. The two-ply laminating stack typically includes an idler roll 34 receiving the mesh 10, and a lay-on roll 36 receiving the laminating film 28. The mesh 10 and laminating film 28 are pressed into intimate contact between the lay-on roll and the heating-and-combining drum 38, and can be heated by the drum and take-off heat roll 40, where the biodegradable mesh-and-film-laminate can be utilized for further processing in making the mesh-and-film stent.

25 When the mesh is to be laminated on both sides, the mesh 10 and film layers 28, 29 can be bonded together by typical three-ply fusion lamination rolls, as is illustrated in Fig. 6. Such a three-ply fusion lamination system 42 typically can include a first preheat-roll system 44 for receiving and preheating one laminating film 28, a second preheat-roll system 46 for

receiving and preheating the mesh 10, and a lay-on roll 48 for pressing the fibrous mesh and first laminating film together in intimate contact against the heating-and-combining drum 50. A third preheat-roll system 52  
5 can be provided, to receive and preheat the second laminating film 29, and a lay-on roll 54 to press the second laminating film and mesh together in intimate contact against the drum. The mesh and two layers of laminating film can be further heated by the drum and  
10 take-off heat roll 56, and removed for further processing in making the mesh-and-film stent. Other laminating systems that combine the mesh with one or more of the laminating films and heat the mesh to melt the low-temperature melting polymer during the lamination process  
15 to produce the film with a reinforced polymer weave also may be suitable. In one implementation of the invention, the mesh and laminating films typically are heated during lamination to a temperature in the range of from about 48.9°C to 165.6°C (about 120°F to about 330°F), and most  
20 preferably from about 82.2°C to 132.2°C (about 180°F to 270°F), to melt the low-temperature melting polymer fiber to produce the biodegradable composite mesh-and-film. In testing with a three-roll stack type of fusion lamination equipment, it was found that adequate bonding of the film  
25 layer to the mesh typically occurred when the lamination was performed at a roll speed of about 0.06-1.52 meters per minute (about 0.2-5 feet per minute), and preferably at about 0.46 meters per minute (about 1.5 feet per minute), with a silicone release film. The ranges of  
30 laminating temperatures and appropriate roll speeds for the lamination equipment can be expected to vary for different types of equipment, and with different thicknesses and types of materials. For improved adhesion of the thin film to the mesh, the mesh  
35 optionally can be dipped in a suitable adhesive before laminating the thin film to the mesh. After the lamination process is complete, the biodegradable mesh-

and-film material then can be cut, preferably with a laser, such as a continuous CO<sub>2</sub> laser, a pulsed YAG laser, or an excimer laser, or alternatively, by stamping, to form the stent.

5                   The biodegradable mesh-and-film-laminate preferably is cut in a shape that can be used as a stent 60, such as the "belt-buckle" shape illustrated in Fig. 9, so that the ends of the stent can be joined to form a contractible, expandable loop, as shown in Fig. 10.

10                   The stent 60 preferably includes a first end 62, a second end 64, and a main body portion 66 between the first and second ends. The main body portion also can include a plurality of apertures 68 to facilitate the process of degradation and absorption of the stent once it is

15                   implanted. The first end preferably includes a slot 70 for receiving and retaining the second end. The second end and main body portion thus are insertable through the slot so as to form a cylindrically, loop shaped stent 72 that can be furled and contracted for placement within a

20                   blood vessel. The second end includes a widened portion 74 for retaining the second end inserted in the slot, and the main body portion includes a plurality of serrations 76 along each side 78 of the main body portion dimensioned to provide a firm interference fit in the

25                   slot, for releasably engaging the slot to adjustably retain the main body portion in the slot. The stent can be placed in a blood vessel in a furled, cylindrical, contracted loop configuration with a sufficiently small outer diameter so as to be transportable through the

30                   targeted blood vessel or other lumen, and of a sufficiently large internal diameter to receive an inflation balloon device (not shown) therein. The stent thus can be urged into an unfurled, expanded configuration by inflation of the inflation balloon

35                   device, and locked in the desired expanded configuration by the serrations on the sides of the main body portion so that the stent cannot re-contract.

It thus has been demonstrated that the invention provides for a stent made of a mesh of biodegradable fibers that can be closely packed for strength, and that further is reinforced with a biodegradable film lamination. The method of manufacture of the biodegradable mesh-and-film stent of the invention provides for good bonding of the laminating film to the fibrous mesh layer of the stent by incorporating a relatively lower-temperature melting, biodegradable polymeric material into a composite biodegradable fiber mesh. The composite mesh then is laminated with a thin film of biodegradable material that strengthens the composite mesh of biodegradable material, without significantly increasing the thickness of the composite mesh. Lamination of the mesh of the stent with one or more film reinforcing layers that can absorb and release drugs allows selected drugs to be released within the affected blood vessel upon implantation.

In the foregoing description, statements concerning specific dimensions, temperatures, weave patterns and weave densities are given by way of example, and it should be apparent to one of ordinary skill in the art that other similar dimensions, temperatures, weave patterns and weave densities also may be suitable according to the principles of the invention. It also should be readily apparent that a stent according to the principles of the invention can be utilized to treat other conditions of vessels or lumens within the body, such as abdominal aorta aneurism, or prostate cancer, in which a stent can be placed within the urethra, and a chemotherapeutic drug can be released directly into the urethra.

It therefore will be apparent from the foregoing that while particular forms of the invention have been illustrated and described, various modifications can be made without departing from the spirit and scope of the invention. Accordingly, it is

not intended that the invention be limited, except as by the appended claims.

-19-

## WHAT IS CLAIMED IS:

1. A biodegradable laminated fibrous mesh,  
comprising:  
a mesh layer having first and second sides,  
5 said mesh layer being formed from a plurality of fibers  
of a first biodegradable polymer and from a second  
biodegradable adhesive polymer characterized by a lower  
melting temperature than the melting temperature of said  
first biodegradable polymer, the first biodegradable  
10 polymer and the second biodegradable adhesive polymer  
being heat bonded together; and  
at least one layer of a film of a biodegradable  
polymer bonded to said mesh layer on at least one side of  
said mesh layer to form a sheet of biodegradable mesh and  
15 film material.
2. The mesh of claim 1, wherein said first  
biodegradable polymer is selected from the group  
consisting of polyglycolic acid, poly-L-lactic acid,  
polyorthoesters, polyanhydrides, polyiminocarbonates, and  
20 inorganic calcium phosphate.
3. The mesh of claim 1, wherein the second  
biodegradable adhesive polymer is selected from the group  
consisting of polycaprolactone, poly-DL-lactic acid, a  
combination of poly-L-lactic acid and polycaprolactone,  
25 polyorthoesters, aliphatic polycarbonates,  
polyphosphazenes, and combinations thereof.
4. The mesh of claim 1, wherein said mesh layer of  
fibers of a first biodegradable polymer has a weave  
density of from about 25.4 to about 508 per centimeter  
30 (10 to about 200 per inch).
5. The mesh of claim 1, wherein said mesh layer is  
laminated with a layer of film on both sides to

encapsulate the mesh.

6. The mesh of claim 1, wherein said laminating layer of film is formed from a biodegradable polymer selected from the group consisting of poly-DL-lactic acid  
5 and poly-L-lactic acid.

7. A method of making a biodegradable laminated fibrous mesh, comprising the steps of:

forming a mesh of a plurality of fibers of a first biodegradable polymer and a second biodegradable  
10 polymer, said second biodegradable adhesive polymer melting at a temperature lower than said first biodegradable polymer;

heating the mesh to melt the second biodegradable adhesive polymer  
15 to a temperature from about 49° to 165.5° C (120° to about 330° F); and

laminating the mesh with at least one laminating film.

8. The method of claim 7, wherein said step of  
20 forming a mesh comprises co-weaving a fiber of said first biodegradable polymer and a fiber of said second biodegradable adhesive polymer.

9. The method of claim 7, wherein said step of forming a mesh comprises co-weaving said plurality of  
25 fibers of said first biodegradable polymer and a plurality of fibers of said second biodegradable adhesive polymer.

10. The method of claim 9, wherein said step of co-weaving comprises co-weaving pairs of said fibers of said  
30 first biodegradable polymer and said fibers of said second biodegradable adhesive polymer in a plain weave pattern.

-21-

11. The method of claim 7, wherein said step of forming a mesh comprises co-mingling said plurality of fibers of said first biodegradable polymer and a plurality of fibers of said second biodegradable adhesive polymer to form a plurality of co-mingled fibers of said first and second polymers, and weaving said co-mingled fibers in a mesh.

12. The method of claim 7, wherein said step of forming a mesh comprises coating said plurality of fibers of said first biodegradable polymer with said second biodegradable adhesive polymer, and weaving a mesh of said plurality of said first biodegradable polymeric fibers coated with said second biodegradable adhesive polymer.

13. The method of claim 7, wherein said step of laminating said mesh is carried out at a temperature of from about 82° to about 132.2° C (about 180° to about 270° F).

14. A biodegradable mesh and film stent for use in maintaining the patency of blood vessels, said stent comprising:

a mesh layer having first and second sides, formed from a plurality of fibers of a first biodegradable polymer and from a second biodegradable adhesive polymer characterized by a lower melting temperature than the melting temperature of said first biodegradable polymer, the first biodegradable polymer and the second biodegradable adhesive polymer being heat bonded together;

at least one layer of a film of a biodegradable polymer bonded to said mesh layer on at least one side of said mesh layer to form a sheet of biodegradable mesh and film material;

said sheet of biodegradable mesh and film

-22-

material having first and second ends, a main body  
portion between said first and second ends, and means on  
each of said first and second ends to retain one said end  
in the other said end, said sheet of biodegradable mesh  
5 and film material being rolled up into a cylindrical  
configuration whereby said first end overlaps and is  
retained by said retaining means to said second end.

15. The stent of claim 14, wherein said first  
biodegradable polymer is selected from the group  
10 consisting of polyglycolic acid, poly-L-lactic acid,  
polyorthoesters, polyanhydrides, polyiminocarbonates, and  
inorganic calcium phosphate.

16. The stent of claim 14, wherein said second  
biodegradable adhesive polymer is selected from the group  
15 consisting of polycaprolactone, poly-DL-lactic acid, a  
combination of poly-L-lactic acid and polycaprolactone,  
polyorthoesters, aliphatic polycarbonates,  
polyphosphazenes, and combinations thereof.

17. The stent of claim 14, wherein said mesh layer  
20 of fibers of a first biodegradable polymer has a weave  
density of from about 25.4 to about 508 fibers per  
centimeter (about 10 to about 200 fibers per inch).

18. The stent of claim 14, wherein said mesh layer  
is laminated with a layer of film on both sides to  
25 encapsulate the mesh.

19. The stent of claim 14, wherein said laminating  
layer of film is formed from a biodegradable polymer  
selected from the group consisting of poly-DL-lactic acid  
and poly-L-lactic acid.

30 20. A method of making a biodegradable mesh and  
film stent for use in maintaining the patency of blood

-23-

vessels, comprising the steps of:

forming a sheet of biodegradable mesh from a plurality of fibers of a first biodegradable polymer and a second biodegradable adhesive polymer, the second  
5 biodegradable adhesive polymer melting at a lower temperature than the first biodegradable polymer;

heating the sheet of mesh to a temperature above the melting point of the second biodegradable adhesive polymer but below that of the melting point of  
10 the first polymer;

placing at least one laminating film on at least one side of the mesh;

heating the laminating film and the mesh to laminate the film to the mesh; and

15 cutting the sheet of biodegradable mesh together with the laminating film into a shape to form a the stent, the stent being formed to included first and second ends, a main body portion between the first and second ends, and means on each of said first and second  
20 ends to retain one said end in the other said end;

rolling the sheet of biodegradable mesh and laminating film into a cylindrical configurations whereby the first end overlaps and is retained by the retaining means to the second end.

25 21. The method of claim 20, wherein said mesh and film are heated to a temperature of from about 49° to about 165.5° C (about 120° to about 330° F).

22. The method of claim 20, wherein said mesh and film are heated to a temperature of from about 82° to  
30 about 132.2° C (about 180° to about 270° F).

23. The method of claim 20, wherein said step of forming a mesh comprises co-weaving a fiber of said first biodegradable polymer with a fiber of said second biodegradable adhesive polymer.

-24-

24. The method of claim 23, wherein said step of forming a mesh comprises co-weaving a plurality of said fibers of said first biodegradable polymer and a plurality of fibers of said second biodegradable adhesive  
5 polymer.

25. The method of claim 24, wherein said step of co-weaving comprises co-weaving pairs of said first biodegradable polymeric fiber and said fibers of said second biodegradable adhesive polymer in a plain weave  
10 pattern.

26. The method of claim 20, wherein said step of forming a mesh comprises co-mingling said plurality of fibers of said first biodegradable polymeric fibers and a plurality of fibers of said second biodegradable adhesive  
15 polymer to form a plurality of co-mingled fibers of said first and second polymers, and weaving said co-mingled fibers in a mesh.

27. The method of claim 20, wherein said step of forming a mesh comprises coating said plurality of fibers  
20 of said first biodegradable polymer with said second biodegradable adhesive polymer, and weaving a mesh of said plurality of said first biodegradable polymeric fibers coated with said second biodegradable adhesive polymer.

28. The method of claim 20, wherein said step of forming a mesh comprises coating a plurality of individual fibers of said first biodegradable polymer with said second biodegradable adhesive polymer to form a plurality of individually coated fibers of said first  
25 biodegradable polymer, and weaving a mesh of said plurality of individually coated fibers of said first biodegradable polymer.  
30

-25-

29. The method of claim 20, wherein said step of cutting said sheet of biodegradable mesh and film material comprises cutting said mesh and film laminated with a laser.

5 30. A biodegradable mesh and film stent for use in maintaining the patency of blood vessels, said stent comprising:

a mesh layer having first and second sides, formed from a plurality of fibers of a first  
10 biodegradable polymer and from a second biodegradable adhesive polymer characterized by a lower melting temperature than the melting temperature of said first biodegradable polymer, the first biodegradable polymer and the second biodegradable adhesive polymer being heat  
15 bonded together;

at least one layer of a film of a biodegradable polymer bonded to said mesh layer on at least one side of said mesh layer to form a sheet of biodegradable mesh and film material;

20 said sheet of biodegradable mesh and film material having first and second ends and a main body portion between said first and second ends, said first end having a surface defining a slot for receiving said second end, said second end and said main body portion  
25 being insertable through said slot so as to form a loop, said second end having means for retaining said second end inserted in said slot, said main body portion having means for releasably engaging said slot to adjustably retain said main body portion in said slot.

30 31. The stent of claim 30, wherein said first biodegradable polymer is selected from the group consisting of polyglycolic acid, poly-L-lactic acid, polyorthoesters, polyanhydrides, polyiminocarbonates, and inorganic calcium phosphate.

-26-

32. The stent of claim 30, wherein said second biodegradable adhesive polymer is selected from the group consisting of polycaprolactone, poly-DL-lactic acid, a combination of poly-L-lactic acid and polycaprolactone, 5 polyorthoesters, aliphatic polycarbonates, polyphosphazenes, and combinations thereof.

33. The stent of claim 30, wherein said mesh layer of fibers of said first biodegradable polymer has a weave density of from about 25.4 to about 508 fibers per 10 centimeter (about 10 to 200 fibers per inch).

34. The stent of claim 30, wherein said mesh layer is laminated with a layer of film on both sides to encapsulate the mesh.

35. The stent of claim 30, wherein said laminating 15 layer of film is formed from a biodegradable polymer selected from the group consisting of poly-DL-lactic acid and poly-L-lactic acid.

36. The stent of claim 30, wherein said means for retaining said second end inserted in said slot comprises 20 a widened portion of said second end.

37. The stent of claim 30, wherein said main body portion includes first and second side edges, and said means in said main body portion for releasably engaging said slot to adjustably retain said main body portion in 25 said slot comprises a plurality of serrations along each side edge of the main body portion dimensioned to provide a firm interference fit in the slot.

38. A method of making a biodegradable mesh and film stent for use in maintaining the patency of blood 30 vessels, comprising the steps of:

forming a mesh of a plurality of fibers of a

-27-

first biodegradable polymer and a second biodegradable adhesive polymer, said second biodegradable adhesive polymer melting at a lower temperature than the first biodegradable polymer;

5                   placing at least one laminating film on at least one side of said mesh;

                  heating said laminating film and mesh to melt said second biodegradable adhesive polymer and form a mesh and film laminate; and

10                   cutting the mesh and film laminate in a shape to form said stent, said stent being formed to include first and second ends and a main body portion between said first and second ends, said first end having a surface defining a slot for receiving said second end,  
15                   said second end and said main body portion being formed to be insertable through said slot so as to form a loop, said second end being formed to include means for retaining said second end inserted in said slot, and said  
20                   main body portion being formed to have means for releasably engaging said slot to adjustably retain said main body portion in said slot.

39. The method of claim 38, wherein said laminating film and mesh are heated to a temperature of from about 49° to about 165.6° C (about 180° to about 270° F).

25                   40. The method of claim 38, wherein said step of laminating said mesh is carried out at a temperature of from about 82.2° to about 132.2° C (about 180° to about 270° F).

30                   41. The method of claim 38, wherein said step of forming a mesh comprises co-weaving a fiber of said first biodegradable polymer with a fiber of said second biodegradable adhesive polymer.

42. The method of claim 41, wherein said step of

-28-

forming a mesh comprises co-weaving a plurality of said fibers of said first biodegradable polymer and a plurality of fibers of said second biodegradable adhesive polymer.

5           43. The method of claim 42, wherein said step of co-weaving comprises co-weaving pairs of said first biodegradable polymeric fiber and said fibers of said second biodegradable adhesive polymer in a plain weave pattern.

10           44. The method of claim 38, wherein said step of forming a mesh comprises co-mingling said plurality of said first biodegradable polymeric fibers and a plurality of fibers of said second biodegradable adhesive polymer to form a plurality of co-mingled fibers of said first  
15 and second polymers, and weaving said co-mingled fibers in a mesh.

            45. The method of claim 38, wherein said step of forming a mesh comprises coating said plurality of fibers of said first biodegradable polymer with said second  
20 biodegradable adhesive polymer, and weaving a mesh of said plurality of said first biodegradable polymer coated with said second biodegradable adhesive polymer.

            46. The method of claim 38, wherein said step of forming a mesh comprises coating a plurality of  
25 individual fibers of said first biodegradable polymer with said second biodegradable adhesive polymer to form a plurality of individually coated fibers of said first biodegradable polymer, and weaving a mesh of said plurality of individually coated fibers of said first  
30 biodegradable polymer.

            47. The method of claim 38, wherein said step of cutting said mesh and film laminate comprises cutting

-29-

said mesh and film laminate with a laser.

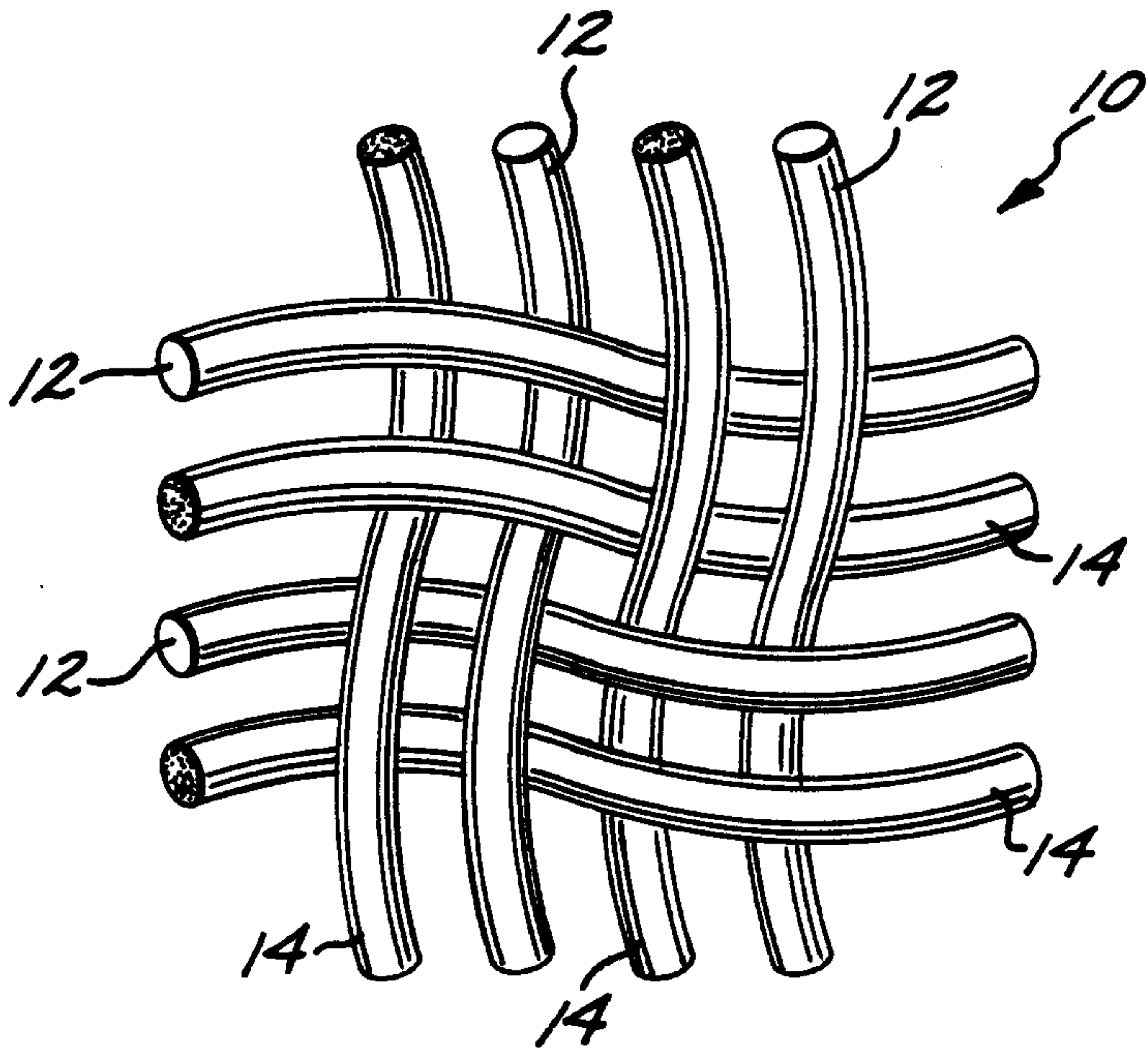

FIG. 1

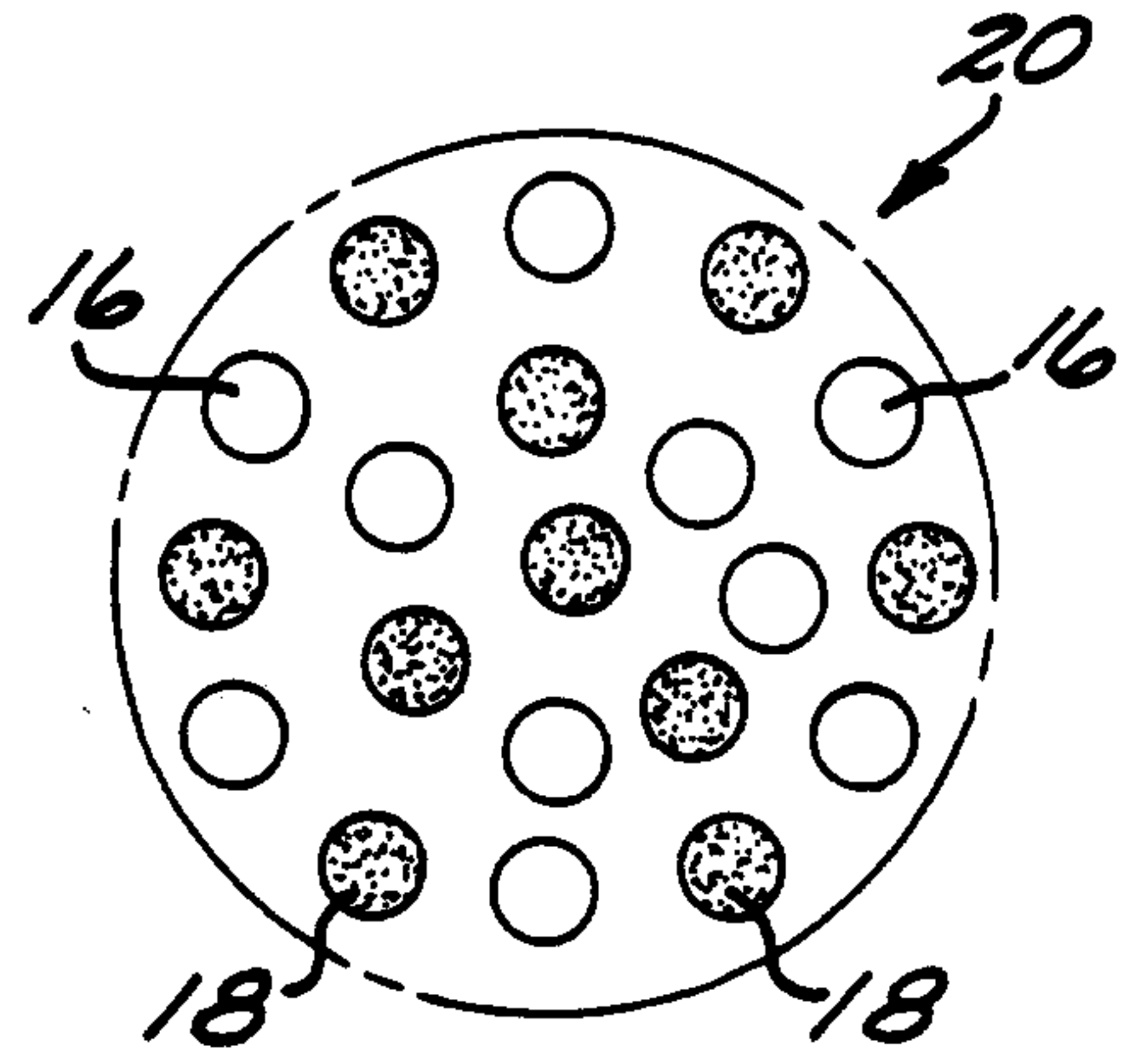

FIG. 2

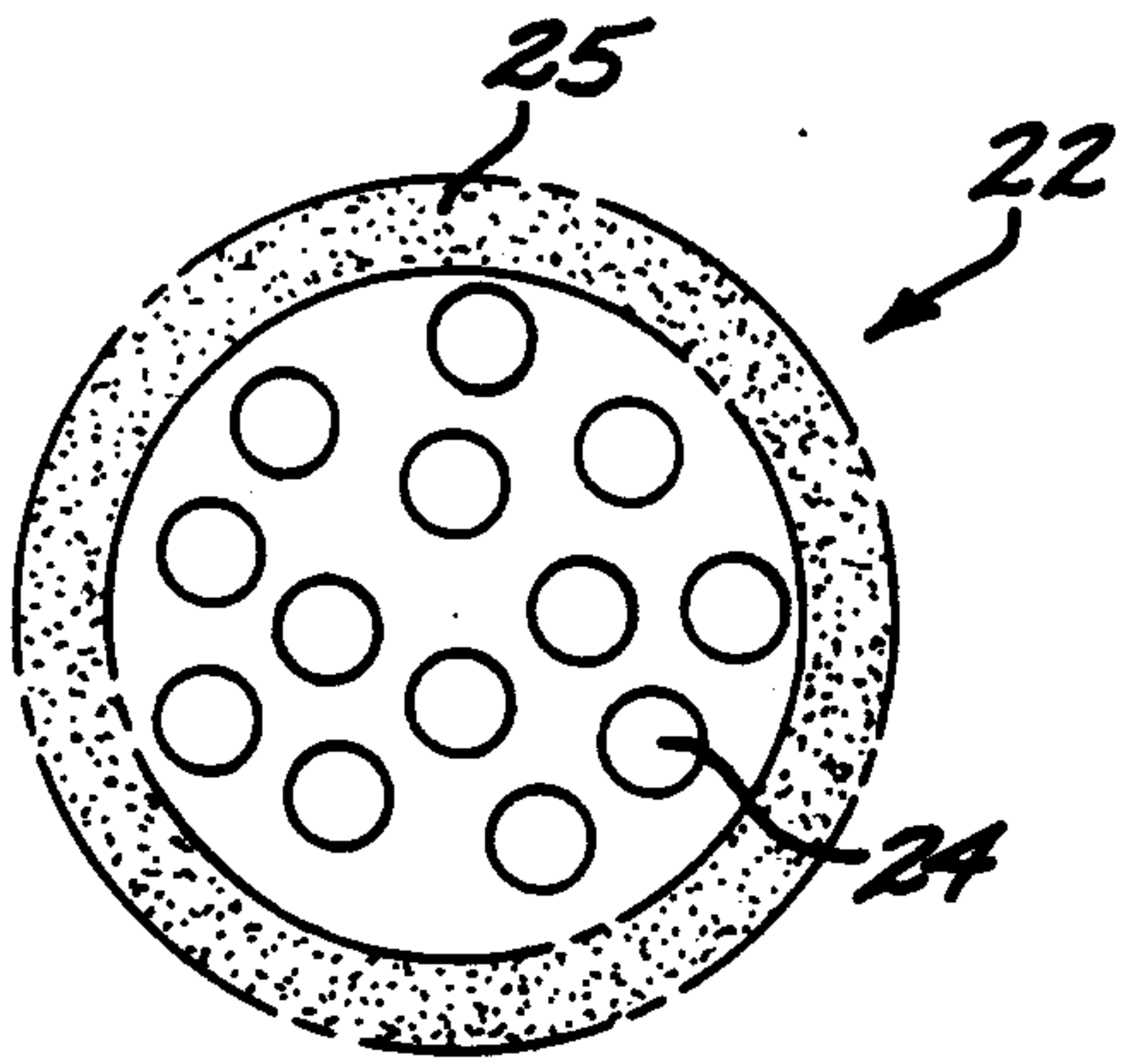

FIG. 3

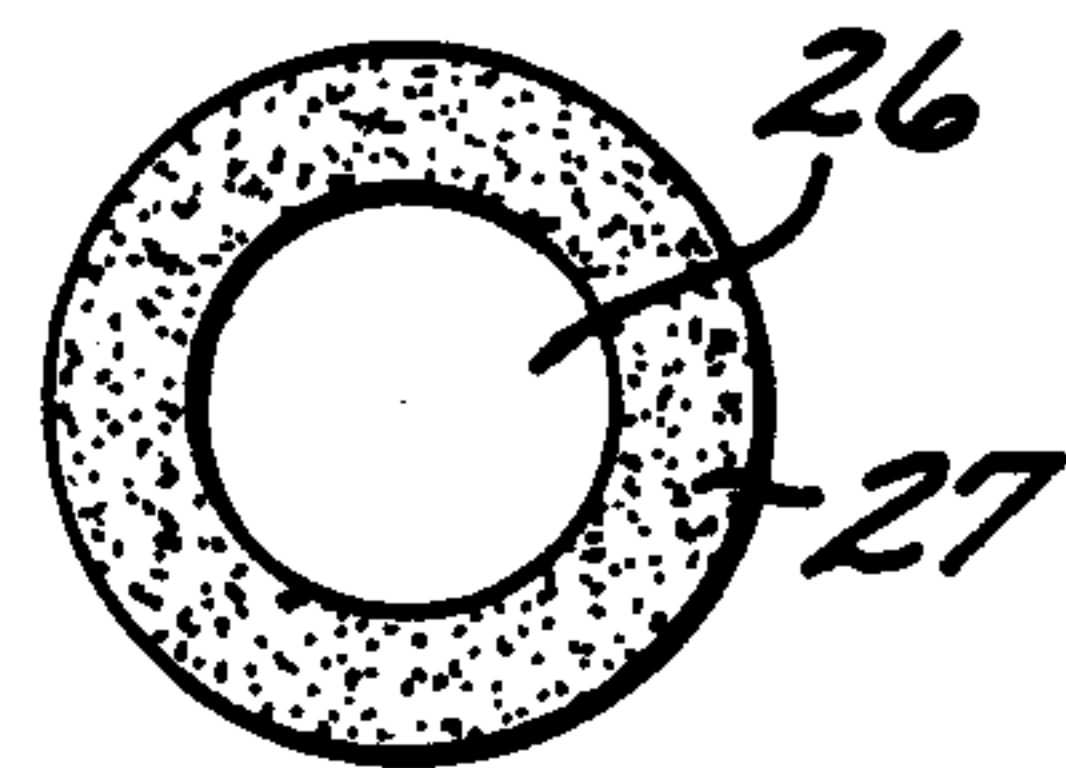

FIG. 4

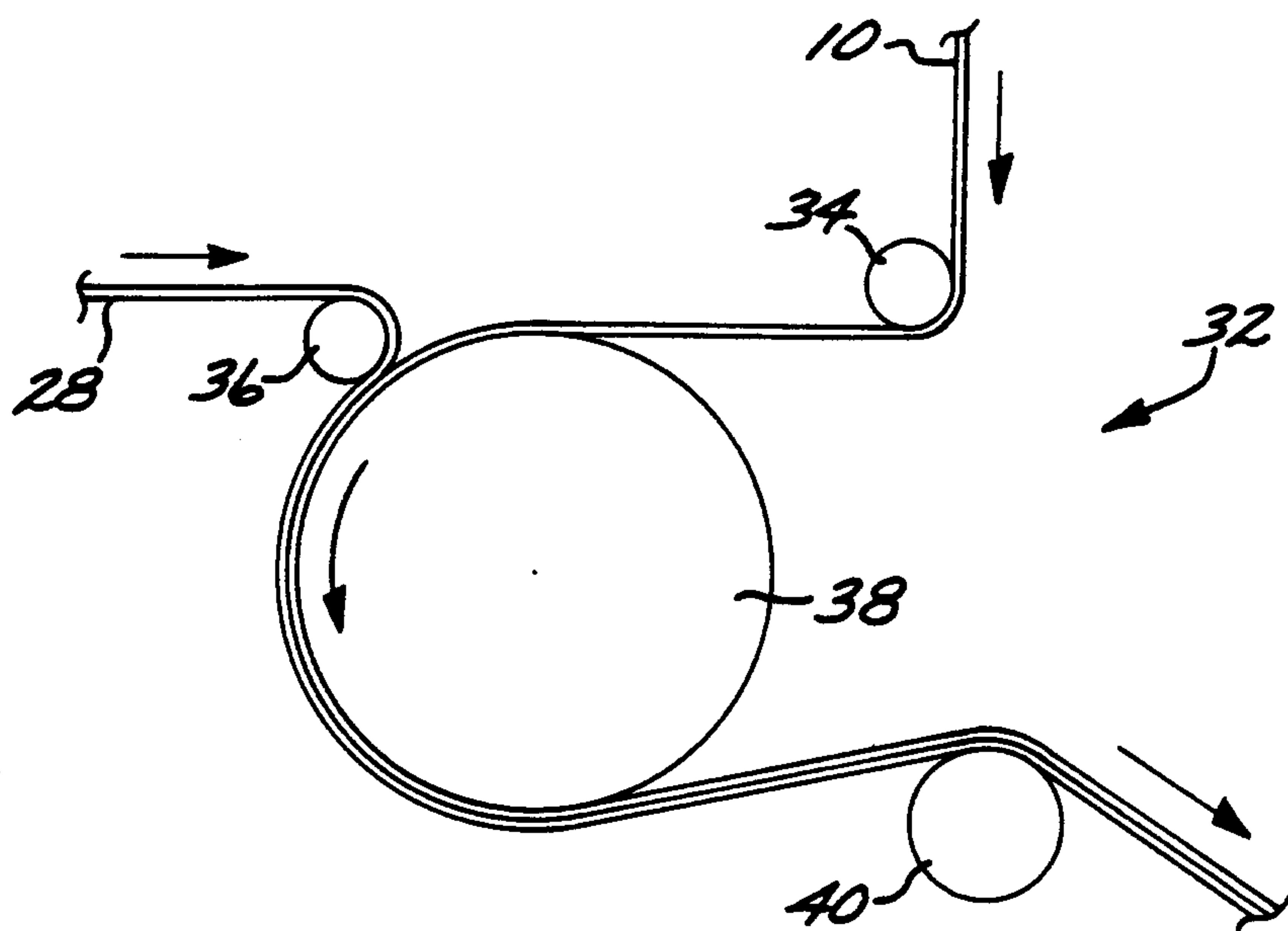

FIG. 5

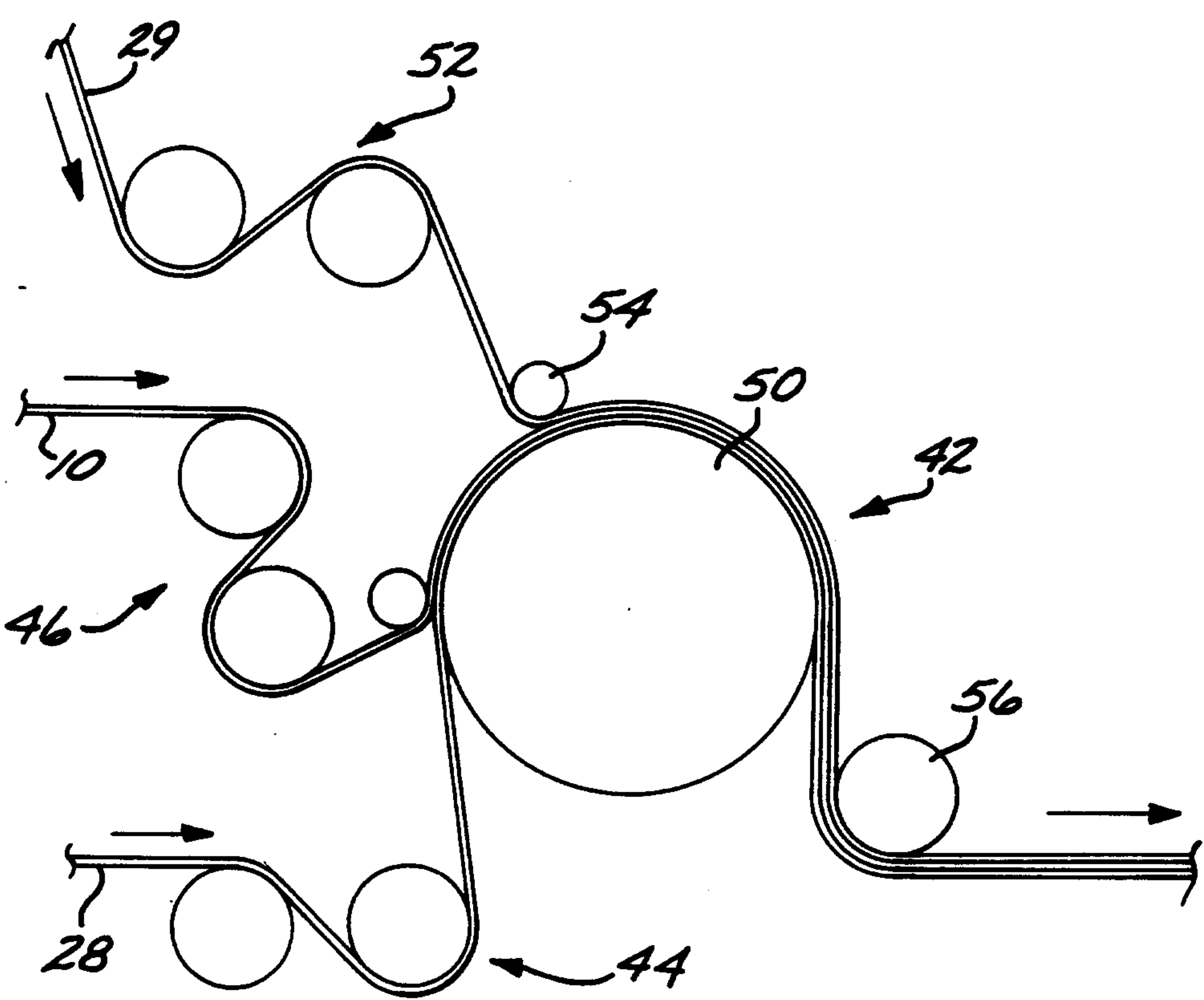

FIG. 6

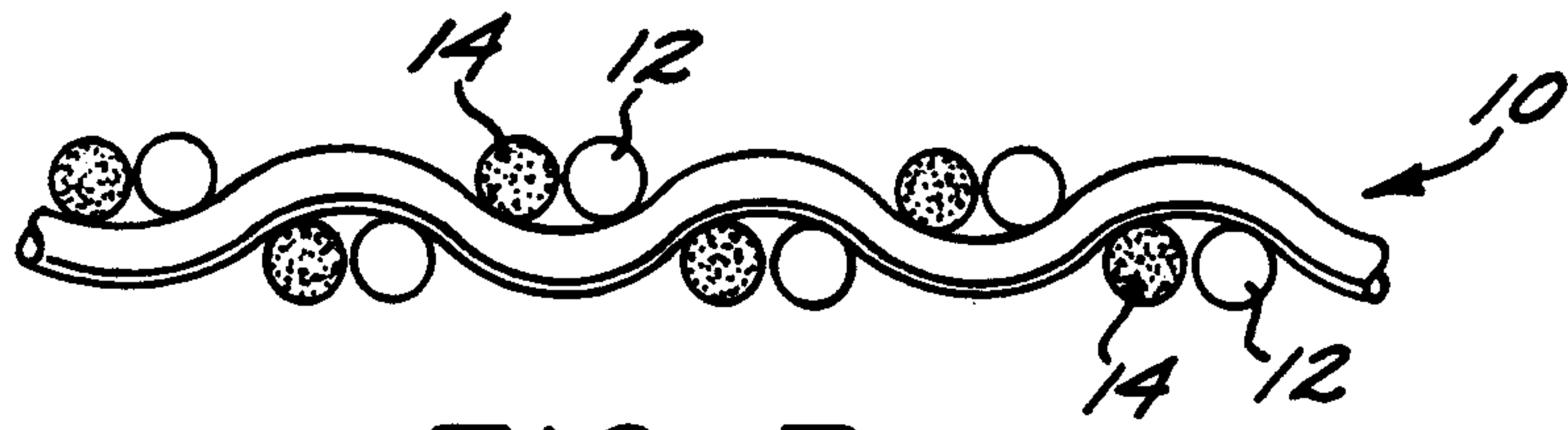

FIG. 7

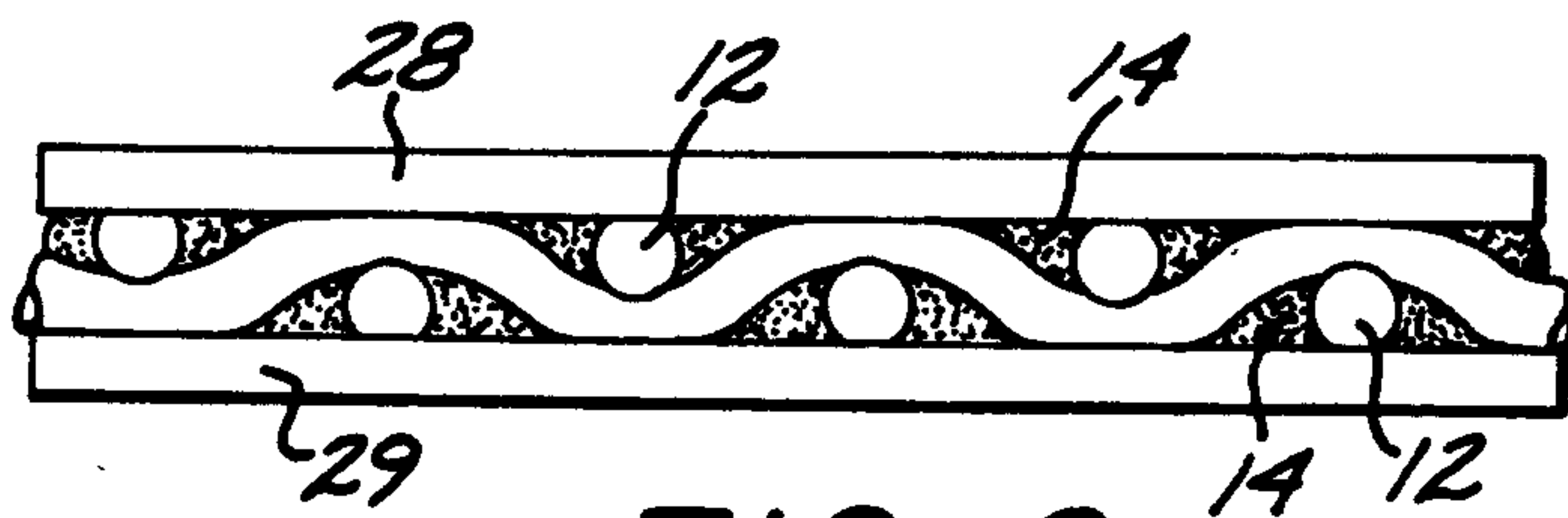

FIG. 8

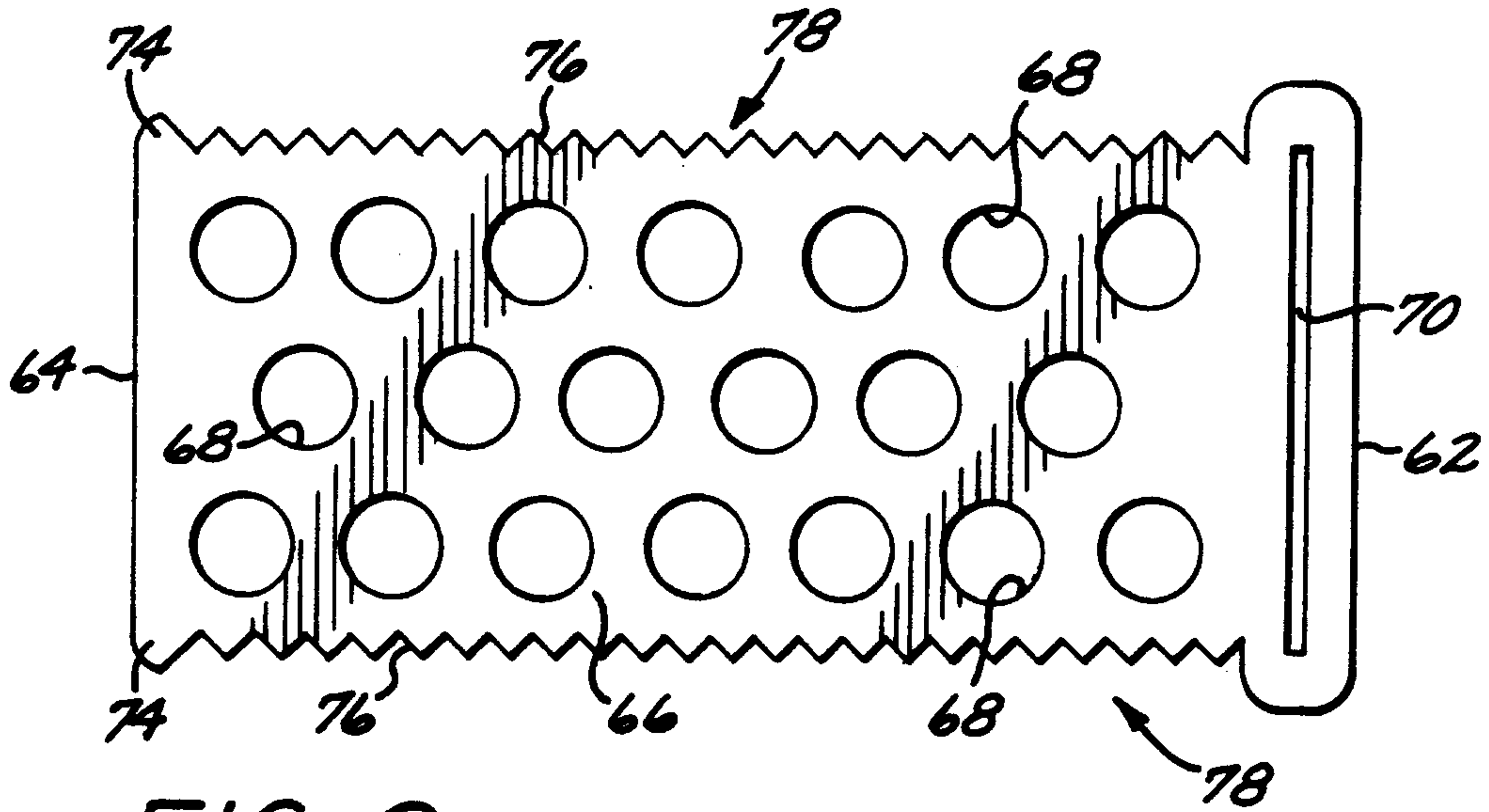

FIG. 9

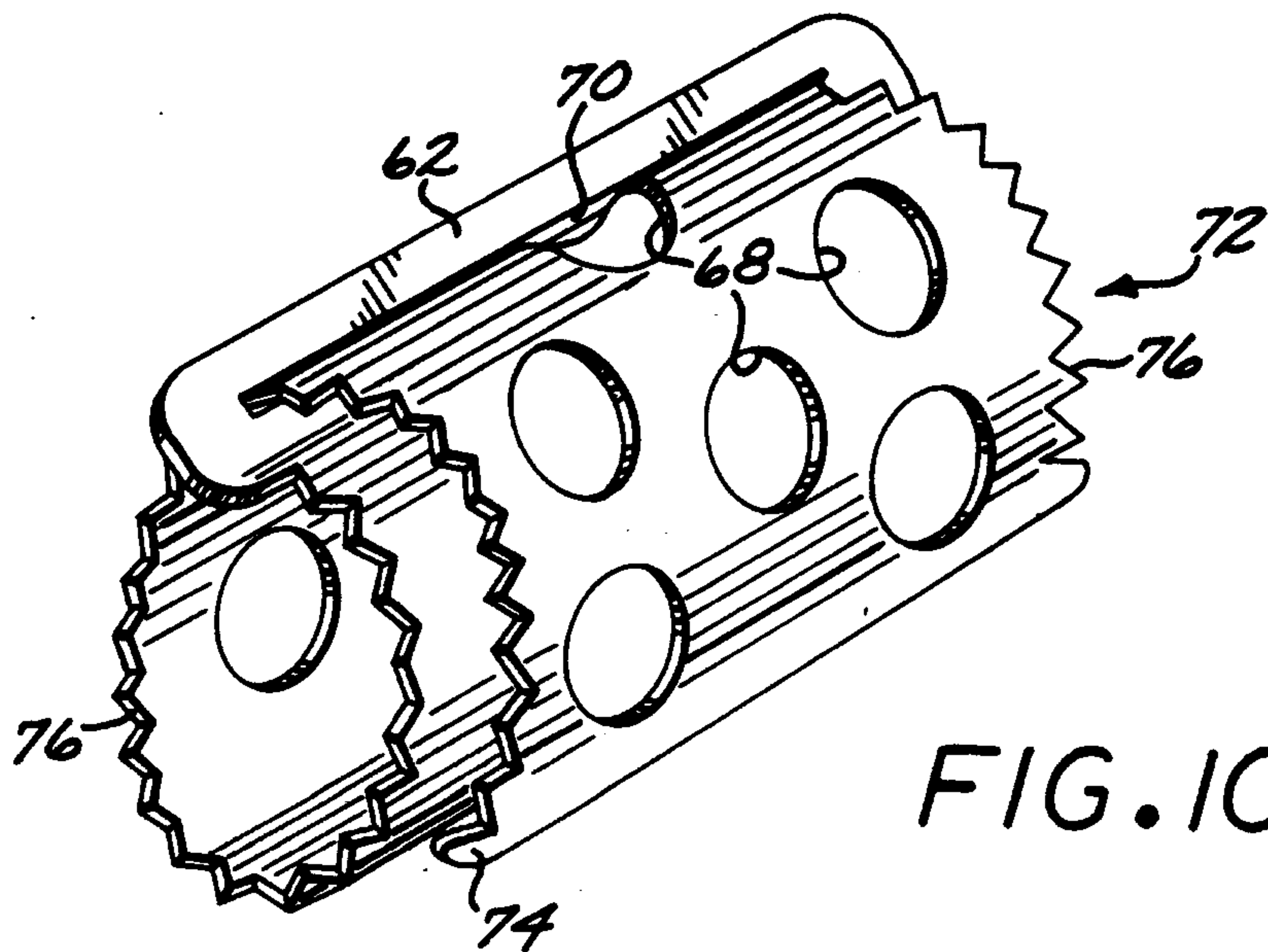

FIG. 10

