

(No Model.)

H. McDONALD.

CASTER.

No. 282,099.

Patented July 31, 1883.

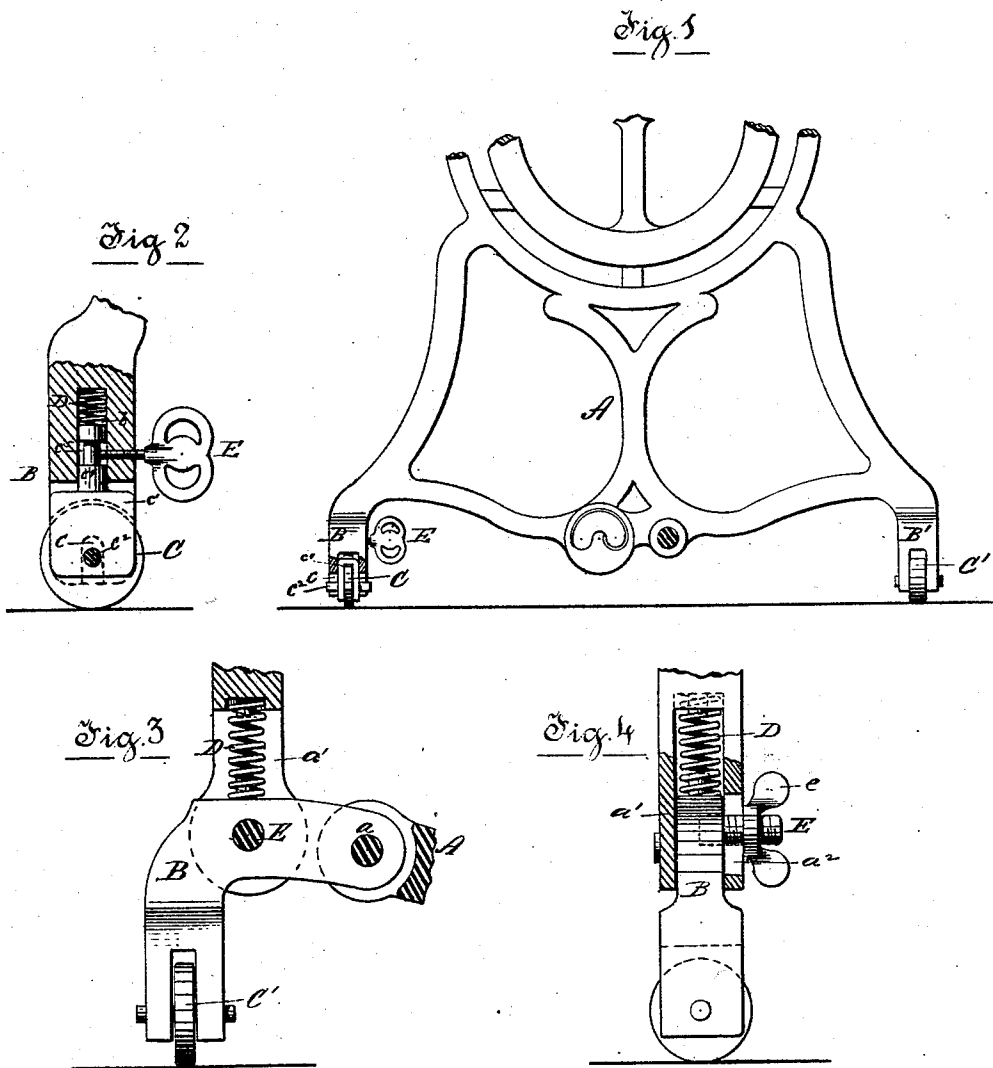

Witnesses:

*Ed. Steal*  
*Wm. B. Reese*

Inventor.  
*Hugh M. Donald*  
Per *R. C. Helms*  
Attorney.

# UNITED STATES PATENT OFFICE.

HUGH McDONALD, OF PLATTSBURG, NEW YORK, ASSIGNOR OF ONE-HALF  
TO DUGALD GRAHAM, OF MONTREAL, CANADA.

## CASTER.

SPECIFICATION forming part of Letters Patent No. 282,099, dated July 31, 1883.

Application filed November 4, 1882. (No model.)

*To all whom it may concern:*

Be it known that I, HUGH McDONALD, of the village of Plattsburg, in the county of Clinton and State of New York, have invented a certain new and useful Improvement in Caster Attachments; and I do hereby declare that the following is a full, clear, and exact description of the same.

This invention relates to a caster attachment for the legs of sewing-machines, tables, &c., and has for its object to permit the same to be adjusted in order to provide for any unevenness of the floor, and thus steady and render rigid the article to which it is attached.

It may be briefly described as consisting in the combination, with the leg of a sewing-machine or other stand or table, of a caster or roller which can be adjusted to the floor automatically or otherwise; but to thoroughly comprehend my invention reference must be had to the accompanying drawings, in which letters similar to those used in the following description indicate like parts, and where—

Figure 1 is a view of part of a sewing-machine or other like stand embodying my invention. Fig. 2 is an enlarged sectional elevation of my caster attachment and means for adjusting same. Fig. 3 is a sectional elevation illustrating a modification of my invention; and Fig. 4 is another view, partly in section, of said modification.

Letter A represents the stand of any sewing-machine, table, or other article of furniture or machine requiring casters, B B' being the extensions or legs to which the casters C C' are attached. Those marked C' are of any ordinary or suitable construction; but to one leg is attached the caster C, constructed and arranged as shown in Fig. 2—viz., with a slot, *c*, in each arm of a fork formed at the lower end of the extension B, in which the pivot-pin *c'* of the caster-stock *c'* can work up and down. This caster-stock *c'* has also a vertical spindle, *c'*, which fits into a suitable hole or recess, *b*, in the leg B, said recess containing also a coiled spring, D, which bears upon the upper end of the caster-spindle *c'*, the latter being also acted upon by a thumb-

screw, E, working in a hole in the leg B into a suitable groove, *c''*, in the spindle *c'*.

The operation of the above device will be easily understood; but I may explain that by loosening the thumb-screw E the spring D forces the spindle *c'*, and consequently the caster-stock *c'* and caster, downward (the pivot-pin *c'* working in the slot *c* of the leg B) until the table or stand is level, when the thumb-screw E is again tightened and the caster thus secured rigidly in place.

It is well known that three legs of a four-legged stand can always find their level together on an uneven floor, and therefore it is only necessary to use my adjustable caster on one leg to effect my object.

In Figs. 3 and 4 I have shown a modified arrangement of my invention, part of the leg B being pivoted at *a* to the frame A, and the caster or roller C' being attached thereto rigidly, the spring D in this case being arranged inside the forked lower end, *a'*, of one of the legs of the main frame to bear on a leveled upper side of the leg B, which is also contained within the fork, and a screw, E, fixed rigidly in the leg B, and working up and down in a slot, *a''*, in the fork *a'*, as shown in Fig. 4, the same being tightened by a thumb-nut, *e*, impinging against the side of the fork.

Many other modifications of my invention might be devised to effect precisely the same purpose and result, such as carrying the spindle *c'* straight up through the turned-out portion of the leg B, (which of course would be shaped accordingly,) and have its upper end screwed and provided with a thumb-nut, on loosening which the spring inside would force down the caster, as will be readily understood; or the spring may be done away with and the caster worked up and down by means of a screw alone, &c., all of which devices would be tributary to my invention.

What I claim, and desire to secure by Letters Patent, is as follows:

1. The combination, with a stand or table the lower end of one of the legs of which is provided with a socket and a fork extending below the socket, of a caster the stock of which

is seated in said fork, a spring compressed within the socket by the upper end of the caster-spindle, and a set-screw to rigidly secure the caster after vertical adjustment, substantially as described.

5 2. The combination, with the frame A, having slotted fork *a'*, and spring D, of the piv-

oted leg B, having fixed caster C', screw E, and thumb-nut *e*, substantially as and for the purpose described.

HUGH McDONALD.

Witnesses:

GEO. L. CLARK,  
B. RAMSAY.