

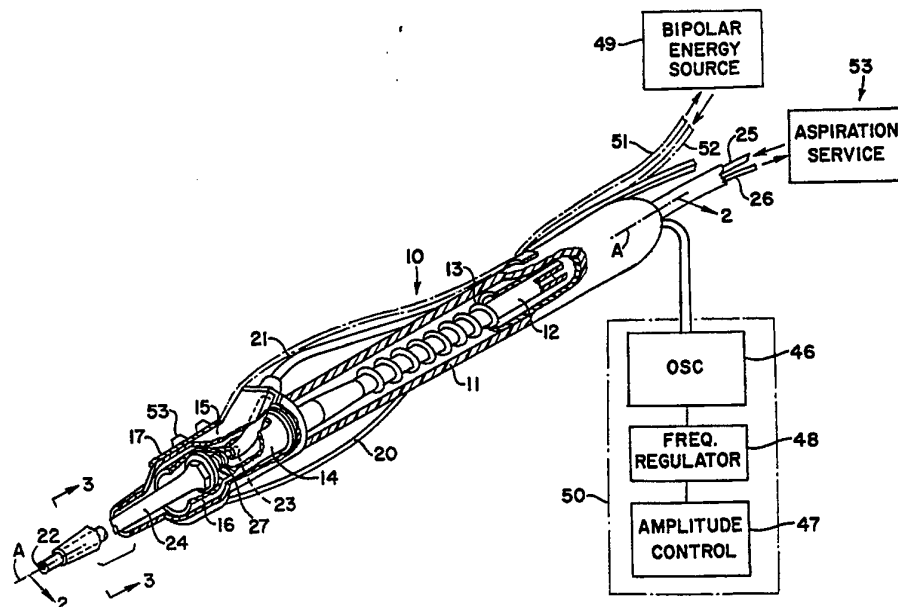

## INTERNATIONAL APPLICATION PUBLISHED UNDER THE PATENT COOPERATION TREATY (PCT)

<p>(51) International Patent Classification<sup>6</sup> : A61B 17/32, 17/39</p>	<p>A1</p>	<p>(11) International Publication Number: <b>WO 95/17855</b> (43) International Publication Date: 6 July 1995 (06.07.95)</p>
<p>(21) International Application Number: PCT/IB94/00332 (22) International Filing Date: 26 October 1994 (26.10.94) (30) Priority Data: 08/175,827 30 December 1993 (30.12.93) US (71) Applicant: VALLEYLAB, INC. [US/US]; 5920 Longbow Drive, Boulder, CO 80301 (US). (72) Inventors: KLICEK, Michael, S.; 1573 Bradley Drive, Boulder, CO 80303 (US). TRUDEL, Gregory, J.; 6821 Idylwild Court, Boulder, CO 80301 (US). (74) Agents: SPIEGEL, Allen, J. et al.; Pfizer Inc., Patent Dept., 235 East 42nd Street, New York, NY 10017 (US).</p>	<p>(81) Designated States: AU, CA, DE, JP, European patent (AT, BE, CH, DE, DK, ES, FR, GB, GR, IE, IT, LU, MC, NL, PT, SE).  <b>Published</b> <i>With international search report.</i></p>	

## (54) Title: BIPOLAR ULTRASONIC SURGERY



## (57) Abstract

An ultrasonic oscillator drives a tool at a set frequency. An amplitude control (47) runs the oscillator to set the vibration level. A frequency regulator (48) joins the amplitude and the oscillator. A handpiece supports a transducer and a vibrating tool. A flue (17) surrounds the tool. Electrodes (42) associated with the flue (17) and/or the tool extend to be at or near the distal tip (18) of the tool and/or the flue (17) and provide bipolar electrosurgery with or without ultrasonic vibration of the tool. A method of performing ultrasonic surgery and bipolar electrosurgery has an ultrasonic handpiece with bipolar electrodes (42) associated with the tool or the flue (17).

**FOR THE PURPOSES OF INFORMATION ONLY**

Codes used to identify States party to the PCT on the front pages of pamphlets publishing international applications under the PCT.

AT	Austria	GB	United Kingdom	MR	Mauritania
AU	Australia	GE	Georgia	MW	Malawi
BB	Barbados	GN	Guinea	NE	Niger
BE	Belgium	GR	Greece	NL	Netherlands
BF	Burkina Faso	HU	Hungary	NO	Norway
BG	Bulgaria	IE	Ireland	NZ	New Zealand
BJ	Benin	IT	Italy	PL	Poland
BR	Brazil	JP	Japan	PT	Portugal
BY	Belarus	KE	Kenya	RO	Romania
CA	Canada	KG	Kyrgystan	RU	Russian Federation
CF	Central African Republic	KP	Democratic People's Republic of Korea	SD	Sudan
CG	Congo	KR	Republic of Korea	SE	Sweden
CH	Switzerland	KZ	Kazakhstan	SI	Slovenia
CI	Côte d'Ivoire	LI	Liechtenstein	SK	Slovakia
CM	Cameroon	LU	Luxembourg	SN	Senegal
CN	China	LV	Latvia	TD	Chad
CS	Czechoslovakia	MC	Monaco	TG	Togo
CZ	Czech Republic	MD	Republic of Moldova	TJ	Tajikistan
DE	Germany	MG	Madagascar	TT	Trinidad and Tobago
DK	Denmark	ML	Mali	UA	Ukraine
ES	Spain	MN	Mongolia	US	United States of America
FI	Finland			UZ	Uzbekistan
FR	France			VN	Viet Nam
GA	Gabon				

5

BIPOLAR ULTRASONIC SURGERY

1. Field of the Invention This relates to bipolar electrosurgery in combination with an ultrasonically vibrated surgical tool, and more particularly, the use of one or more additional electrodes on the irrigation flue or the ultrasonic pipe tool to provide bipolar electrosurgical energy near the tip of the vibrating tool.

2. Background of the Disclosure U.S. Patent 4,674,498 has a vibrating scalpel with electric cautery driven with low frequency vibrations wherein the cutting is by the mechanical action of the sharp knife blade and the vibrations keep the blade free from sticking to the cauterized tissue and bodily fluid. The sticking of tissue and fluid act to destroy the cauterized tissue causing the sealed wound to open. The '498 patent discloses a low frequency heated vibrating scalpel.

U.S. 4,886,060 assigned to Swedemed AB, a Swedish company, has a piezo electrically driven ultrasonically vibrating tool and broadly claims an ultrasonic knife means used with a high frequency emitting source for energy to induce heat in the tissue at the tip of the ultrasonic knife for coagulating the tissue. The tool is electrical isolated from the coagulation means (electrosurgery) to prevent shorting the piezo driver.

U.S. Patent 4,931,047 assigned to Valleylab, of Boulder, Colorado is an ultrasonic apparatus with a vibrating tip to disintegrate tissue at a surgical site. The tip is connected to a radio frequency generator and supplies cutting or coagulating current or a blend thereof to the site. Surgical procedures can thereby be performed using ultrasonic fragmentation and electrosurgery or either approach independently and/or alternatively. The electrosurgery is monopolar in that the energy from the tip passes through the patients tissue to a ground pad attached to the patient's body. The tool supporting the tip is hollow having a bore and irrigation fluid passes through an annular space around the tool to the tip and is aspirated proximally therefrom through the bore thus removing surgical debris from the site. This aspiration technique is known in U.S. Patent 3,693,613.

U.S. Patent 5,015,227 assigned to Valleylab, of Boulder, Colorado pertains to an ultrasonic instrument that includes electrosurgical capabilities. The specifics

of that patent relate to a conductive O-ring to allow the switching at the handpiece of the electrosurgical energy notwithstanding the vibrations of the ultrasonic driver for the fragmenting tool.

Bipolar electrosurgery is typically accomplished by bringing two electrosurgical  
5 electrodes into close proximity to the tissue to be treated and then activating the electrosurgical generator to desiccate the tissue. The current is confined to the area between the two electrodes. Having an ultrasonically vibrating tool interposed between or near the bipolar electrodes has not been done. The entire disclosures of the prior patents are incorporated herein by reference and made a part hereof.

10

#### SUMMARY OF THE INVENTION

A bipolar ultrasonic surgical instrument may have a handpiece for manipulation by a surgeon connected to a bipolar source of electrosurgical radio frequency energy. An electronic oscillator preferably drives the ultrasonic instrument  
15 at a predetermined frequency. An ultrasonic driving circuit may permit the setting of the level of the ultrasonic vibration. A housing is most preferred for holding the handpiece (is held) by the surgeon proximally during use. Leads may connect the bipolar source of electrosurgical radio frequency energy and are carried by the housing.

20 A transducer is preferably within the housing for providing ultrasonic energy. The transducer may be positioned along an axis thereof and may be selected for oscillating along the axis with motion sufficient for ultrasonic surgery at around at least one preferred frequency and wavelength. Pipe tools preferably attach to the transducer so that each pipe tool oscillates around at least the one preferred  
25 frequency and wavelength, each pipe tool may have a central bore there through connected to a source of aspiration. A distal tip on each pipe tool is preferably positioned away from the housing in position for ultrasonic surgery, bipolar electrosurgery or a combination thereof.

A flue may be coaxially disposed about the pipe tool and is preferably  
30 supported for cantilever extension from the housing. An annular space between the pipe tool and the flue may allow passage of irrigating fluid. Two or more electrodes are preferably associated with the pipe tool, flue or either of them and connected in circuit with the leads for selected energization of the electrodes.

The leads may include switching systems added to selectively energize the electrodes. The ultrasonic driving circuit may have an amplitude control connected to the electronic oscillator, a frequency regulator between the amplitude control and the electronic oscillator and a frequency control feedback loop in the frequency  
5 regulator for maintaining the linear dynamics of the ultrasonic surgical instrument about the predetermined frequency.

The two or more electrodes are preferably associated with and electrically insulated from the pipe tool and are connected in circuit with the leads for selected energization of the electrodes. The two or more electrodes may be movably  
10 connected in circuit with the leads through a sliding electrical coupling between the electrodes and the leads for energization of the electrodes and for permitting ultrasonic vibration of the pipe tool. The two or more electrodes may be alternatively associated with the flue and are connected in circuit with the leads for selected energization of the electrodes. At least one of the electrodes is preferably associated  
15 with the flue and at least one of the electrodes may be associated with the pipe tool in an embodiment and the electrodes are perhaps connected in circuit with the leads for selected energization of the electrodes.

The one or more electrodes associated with the pipe tool are each in one configuration movably connected in circuit with its respective lead through a  
20 compliant electrical coupling between the electrode and the lead for energization of the electrode and for permitting ultrasonic vibration of the pipe tool. The one or more electrodes are possibly associated with and electrically insulated from the pipe tool, the one or more electrodes are each connected in circuit with one of the leads and the pipe tool is connected in circuit with the other of the leads for allowing  
25 selected energization of the electrodes. The one or more electrodes associated with the pipe tool are conceivably each movably connected in circuit with their respective lead through a compliant electrical coupling between the electrodes and the lead for energization of the electrodes while for permitting ultrasonic vibration of the pipe tool. The two or more electrodes are perchance each associated with the pipe tool  
30 by being carried on the outside thereof or extending from the housing end thereof to the distal tip. The two or more electrodes each may be in another arrangement associated with the pipe tool by being carried on the inside thereof for extending from the housing end thereof to the distal tip. The two or more electrodes are

possibly each associated a different approach with the pipe tool having at least one carried on the inside thereof and at least one carried on the outside thereof for extending from the housing end thereof to the distal tip. The two or more electrodes are perhaps each associated with the flue in still another way by being carried on the outside thereof for extending from the housing support thereof distally. The two or more electrodes are conceivably each associated with the flue by being carried alternately on the inside thereof for extending from the housing support thereof distally. The two or more electrodes are maybe each associated with the flue having at least one carried on the inside thereof and at least one carried on the outside thereof in another embodiment for extending from the housing support thereof distally. The two or more electrodes are perchance each associated with the pipe tool having at least one carried on the inside thereof and at least one carried on the outside thereof for extending from the housing end thereof to the distal tip in still another arrangement. The two or more electrodes may be respectively associated with the flue and the pipe tool by being carried on the outside of each for extending from the housing distally to permit yet a further form of bipolar electrosurgery with ultrasonic vibration.

The two or more electrodes are perhaps respectively associated with the flue and pipe tool by being carried on the inside of each for extending from the housing support thereof distally. The two or more electrodes may be respectively associated with the flue and the pipe tool by having at least one carried on the inside of either the flue or the pipe tool and contrary to at least one carried on the outside of the pipe tool or the flue for extending from the housing support thereof distally and having at least a bipolar circuit between the outside of one and the inside of the other.

A method of using a bipolar ultrasonic surgical instrument includes a handpiece for manipulation by a surgeon connected to a source of bipolar electrosurgical radio frequency energy. Providing an ultrasonic instrument oscillating at a predetermined frequency is a step. Holding a housing for the handpiece during use is a step. Connecting leads the bipolar source of electrosurgical radio frequency energy is a step. Oscillating a pipe tool attached to the instrument so that each pipe tool oscillates around at least one preferred frequency and wavelength is a step. Positioning a distal tip on the pipe tool away from the housing for ultrasonic, bipolar

electrosurgery or a combination thereof is a step. Disposing a flue coaxially about the pipe tool the flue supported for cantilever extension from the housing is a step. Connecting two or more electrodes associated with the pipe tool, flue or either of them in circuit with the leads for energization of the electrodes with radio frequency  
5 energy is a step.

### **BRIEF DESCRIPTION OF THE DRAWINGS**

Figure 1 is a perspective view of an ultrasonic surgical handpiece with part  
10 of the housing thereof removed so as to show the inside and the components therein and the leads to supply bipolar electrodes associated with the flue and/or the ultrasonic pipe tool.

Figure 2 is a side view of a flue in cross section and an elongate tapered pipe tool therein and has the bipolar electrodes oriented across from one another on the  
15 flue and or pipe tool as would be seen if the cross section were taken along line 2-2 in Figure 1.

Figure 3 a through j are each a cross sectional view of one of the various alternative bipolar electrode configurations possible with the ultrasonic surgical handpiece as would be seen along 3-3 of Figures 1 or 2.

20 Figure 4 is a schematic representation of at least one circuit used to supply electrosurgical energy at radio frequencies to bipolar electrodes associated with the flue.

### **DETAILED DESCRIPTION OF THE INVENTION**

25

The claims are not limited to the structure for an ultrasonic surgical handpiece  
10, a bipolar flue, pipe tool or an bipolar ultrasonic surgical instrument to permit bipolar and/or ultrasonic surgery described and illustrated by way of example and specifically explained. The claims are to be considered in view of the existing  
30 knowledge of skilled artisans in the field prior to the inventions defined by the language of the claims herein, as amended or considered in view of knowledge of skilled artisans prior to these inventions. As used throughout this disclosure proximal or posterior has the meaning near the user and distal or anterior is near the patient.

The reference numbers as seen in the several figures are identical wherein the components are the same.

Figure 1 is a perspective view partially in section showing the ultrasonic surgical handpiece 10, including a housing 11 that encloses a transducer 12, an electric coil 13 and a connecting member 14 extending axial therethrough along an axis A which represents the longitude for the ultrasonic surgical handpiece 10. In front of the housing 11 there is a nose cone 15 tapered from the housing 11 to a distal end 16 thereof to which mounts the extending flue 17 about the nose cone 15 to coaxially surround an axially vibrating metal fragmenting or cutting pipe tool 24. The axially vibrating cutting pipe tool 24 is preferably metal, but might be otherwise, and distal tip 18 of pipe tool 24 extends longitudinally along axis A beyond the flue 17.

A CUSA System 200 with CEM made by Valleylab, 5920 Longbow Drive, Boulder, Colorado, may be used to drive the altered components disclosed herein. That system provides ultrasonic and electrosurgery in a combined instrument and is commercially available. That system has been used only with monopolar electrosurgery. The disclosure herein teaches how to make that system into a bipolar electrosurgical ultrasonic instrument effective for open or laparoscopic procedures.

A manifold assembly 19 composed of two tubes 20 and 21 for irrigation and suction, respectively lies atop and along the housing 11 to reside parallel to axis A. Tube 20 connects to the flue 17 near distal end 16 so as to feed sterile irrigation and cooling fluid down through the flue 17 for flow toward the distal tip 18. The vibration introduced into the distal tip 18 by means of the connecting member 14 generates an acoustic wave or stress resulting in the transformation of some energy into heat. The suction tube 21 draws fluid through at least one preaspiration hole 18a (small of size and shown only in Figures 2, 4 and 5, as will be described hereinafter that provides a portal between the flue 17 and a central bore 22, see figure 3). The central bore 22 of the pipe tool 24 extends between the distal tip 18 and a connection 23 for tube 21.

In Figure 2 there is an enlarged side view in cross section of the flue 17 as would be seen along line 2-2 of Figure 1. In Figures 1 and 2, the flue 17 if elongate for laparoscopic use is shown shortened with a section missing as the preferred full



length of the flue 17 would not fit on the page without reducing the cross section of the ultrasonic surgical handpiece 10 to an extent such that detail would be lost or to a degree so that the diameter to length relationship would be distorted and any appreciation of the relative lengths of the handpiece 10, flue 17 and cutting distal tip 18 could not be understood.

In operation the distal tip 18 is the working end of an elongate tapered hollow metal pipe tool 24, preferably made of titanium alloy tubing of one quarter inch, or 6.3 millimeters, outside diameter and an inside diameter of about .078 inch, or 2 millimeters, for high strength, lightweight lower density than the connecting member, and biologically inert. The pipe tool 24, when part of the acoustic vibrator, is designed to vibrate at a preferred frequency of 23,000 cycles per second so that the distal tip 18 reciprocates longitudinally along axis A with an excursion or peak to peak stroke of about 200 micrometers (.008 inches) for the an elongate laparoscopic pipe tool embodiment. The irrigation flow through tube 20 passes within an annular space between the flue 17 and the elongate pipe tool 24 picking up heat therefrom. The irrigation fluid is sucked through the preaspiration hole 18a shown in Figure 2 near the distal tip 18 and returned through connection 23 to tube 21 near the nose cone 15. Thus, irrigant flows and can while cooling aid the movement of debris, such as cut tissue and blood up from the surgical site through central bore 22 for removal. Longitudinal ultrasonic vibrations of distal tip 18 fragment tissue which it contacts. The excursion or amplitude and frequency of the vibrations are electronically maintained and to some extent are adjustable as will be explained herein so that the vibrations are in accord with the gaussian or harmonic design of elongate pipe tool 24 and the requirements of the surgical procedure being practiced. To avoid failure, a portion of the vibrating pipe tool 24 is shaped with a Gaussian curved profile which results in an essentially flat stress notwithstanding the increased displacement of the free end. In the pipe tool 24 for laparoscopy made of titanium alloy with the stated preferred dimensions, the axial span of each wavelength at the frequency of 23 kilohertz is about 8.7 inches. The overall length of the pipe tool 24 is thus about 12 inches for 5/4 wavelength and 16 inches for 7/4 wavelength.

Numerous shapes, as well as combinations thereof, have been theoretically treated and used as mechanical resonators. There have been attempts by suitable

shaping to extend the zone of maximum elastic stress in the axial direction and thereby make greater amplitudes possible, see U.S. Patent No. 2,984,154. Since the specific technical application constrained four quantities of the resonance element, namely input, node and output cross section and the transmission ratio, the  
5 solution of the resulting problem in variation leads to a function that is Gaussian in profile for the tapered part of the vibrating pipe tool 24.

Tubes 25 and 26 provide circulating coolant to the ultrasonic surgical handpiece 10 as shown by arrows in Figure 1. As explained acoustic vibration of the transducer 12 converts electrical energy to mechanical longitudinal vibrating motion  
10 along axis A and through pipe tool 24 to its vibrating distal tip 18. The preferred transducer 12 is an acoustic vibrator having a laminated nickel alloy structure which is excited by a magnetic field creating oscillating currents passing through the electrical coil winding 13. Coil winding 13 is excited at 23,000 cycles per second (23 kilohertz) alternating current. The resulting longitudinal oscillating motion of the  
15 preferred laminated nickel alloy structure is amplified by a preferred tapered titanium alloy pipe tool 24 which extends from the distal end of the nose cone 15 to the distal end of the vibrating distal tip 18. The pipe tool 24 attaches with threads 27 to the transducer 12 by way of the connecting member 14 interposed therebetween. The taper and wall of the extending titanium pipe tool 24 is designed to be a mechanical  
20 structure such that it vibrates at 23,000 cycles per second.

An embodiment of flue 17 shown in Figure 2, is composed of several pieces which may preferably be made of different polymeric materials since the extremities of the flue 17 should preferably be soft and flexible. There is a central body 28 which is hollow, elongate and semi rigid for extending with and coaxial about the  
25 axis A passing longitudinally and centrally therethrough. Central body 28 terminates in a funnel 29 which is proximal and a nozzle 30 which is distal. The flue 17 is primarily and preferably made of silicone rubber that has a relatively resilient quality whereby the funnel 29 fits tightly over the nose cone 15 of the ultrasonic surgical handpiece 10 forming a fluid tight gasket like seal 31 due to the rubbery resilient  
30 nature of the silicone rubber used.

In Figures 1 and 2, the flue 17 is shown less than its preferred length for laparoscopy, which is about 11 1/2 inches or 29 centimeters. The diameter at the funnel 29 is such that the flue 17 tapers generally toward its nozzle 30. The central

body 28 is hollow throughout. Reinforcing ridges 32 extend longitudinally inside the nozzle 30. A recess 34 may circumscribe the exterior of central body 28 and extend proximally from the funnel 30 to the taper of the nozzle 30. The recess 34 is designed to receive a hollow support surrounding cylinder 35 thereabout for  
5 reinforcement thereof in the embodiment shown. It should be understood and appreciated that the flue 17 can be any length and the reinforcement will be unnecessary with shorter flues. Similarly the pipe tools can and have been made of various sizes and resonance is the basic criteria for the length and configuration of the pipe tool 24.

10 The hollow support surrounding cylinder 35 in the composite polymeric laparoscopic flue 17 is preferably an extruded polysulfone tubular configuration sized to sit within the recess 34 for reinforcement against bending of central body 28. Alternately, the central body 28 can be made of a stiffer construction, i. e. thicker wall or of a coextruded material having a greater modulus since the cross sectional  
15 appearance of such a stiffer molded material would not be apparent, that integral construction is not specifically shown in the Figures. Skilled artisans would appreciate how that could be accomplished. The shorter flue 17 can of course be made of one material as a unitary part.

Funnel 29 which is generally enlarged diametrically relative to axis A and the  
20 rest of the central body 28. The funnel 29 includes a fluid communication port 36 between its inside and outside. The port 36 is arranged to pass fluid from tube 20 which seats within a shouldered opening 37 therein and extends distally from a proximal face 38 thereof. Fluid may pass from the tube 20 through the port 36 into flue 17 and more particularly, the annular space 33 between the flue 17 and the pipe  
25 tool 24. The reinforcing ridges 32 support the nozzle 30 (that has a smaller cross sectional area than the funnel 29 or central body 28) maintaining concentricity relative to the elongate tapered titanium vibrating pipe tool 24 near vibrating distal tip 18 which passes coaxially therethrough, see Figure 1 and 2. More importantly, ridges 32 are generally very slight in height so as not to clamp the pipe tool 24 or  
30 the vibrating distal tip 18 but still separate the flow of irrigation and coolant so that it passes in laminar fashion along the pipe tool 24 and to the distal tip 18. Consequently, the coolant is channelled so the flow is between the ridges 32. For a short flue 17 ridges 32 and channels are not included as the cantilever disposition

of the flue 17 is not sufficient as to warrant them to prevent droop or provide strength.

In particular and as best seen in Figures 1 and 2 the elongate tapered pipe tool 24 has the vibrating distal tip 18 at its patient contacting extreme (for fragmenting) and a threaded fitting 39 at its proximal extreme (for attachment). Threads 27 allow removable connection of the elongate tapered pipe tool 24 to the connecting member 14 as shown in Figure 1.

In Figure 3 the cross section of the flue 17 and the pipe tool 24 is shown with their preferred coaxial relationship. The flue 17 being outside the pipe tool 24. In each of the embodiments the electrodes are designated 42 and the insulators are shown as 43. The electrodes 42 can be any conductive material but are preferably metallic. The insulators 43 may be any electrical resistance material having a high dielectric.

The ultrasonic surgical handpiece 10 has the transducer 12, the electric coil 13 and is driven in the ultrasonic surgical instrument circuit, such as disclosed and explained in United States Serial No. 07/982,936, Filed November 30, 1992 and entitled: ULTRASONIC SURGICAL HANDPIECE AND AN ENERGY INITIATOR. That disclosure, which is assigned to the assignee of this application is incorporated herein and made a part hereof by reference. The ultrasonic surgical instrument circuit for frequency maintenance begins and holds a preset vibrational mode and the linear dynamics of the vibrating distal tip 18 to drive the transducer 12 of the ultrasonic surgical handpiece 10 for operation at resonance characteristics and under varying loads. An electronic oscillator 46 drives the transducer 12 at a predetermined frequency, preferably 23 kilohertz. A user set amplitude control 47 is connected to the electronic oscillator 46. The amplitude control 47 permits manual setting of the level of the ultrasonic vibration. A frequency regulator 48 connects between the amplitude control 47 and the electronic oscillator 46. A frequency control feedback loop may be used with the frequency regulator. The frequency control feedback loop maintains the linear dynamics of the ultrasonic surgical handpiece 10 and vibrating pipe tool 24 about the predetermined frequency during use.

A preferred bipolar ultrasonic surgical instrument of Figures 1 through 4 has the handpiece 10 for manipulation by a surgeon connected to a bipolar source 49 of electrosurgical radio frequency energy. The electronic oscillator 46 drives the

ultrasonic instrument at a predetermined frequency. An ultrasonic driving circuit 50 permits the setting of the level of the ultrasonic vibration. The housing 11 for holding the handpiece 10 is held by the surgeon proximally during use. Leads 51 and 52 connect the bipolar source 49 of electrosurgical radio frequency energy and are  
5 carried by the housing 11.

The transducer 12 is within the housing 11 for providing ultrasonic energy. The transducer 12 is positioned along the axis "A" thereof and is selected for oscillating along the axis "A" with motion sufficient for ultrasonic surgery at around at least one preferred frequency and wavelength. Pipe tools 24 attach to the  
10 transducer 12 so that each pipe tool 24 oscillates around at least the one preferred frequency and wavelength, each pipe tool 24 has the central bore 22 therethrough connected to a source of aspiration 53. A distal tip 18 on the pipe tool 24 is positioned away from the housing 12 in position for ultrasonic surgery, bipolar electrosurgery or a combination thereof.

The flue 17 is coaxially disposed about the pipe tool 24 and is supported for  
15 cantilever extension from the housing 11. The annular space 33 between the pipe tool 24 and the flue 17 allows passage of irrigating fluid. In Figure 3 a through j two or more electrodes 42 may be associated with the pipe tool 24, flue 17 or either of them and connected in circuit with the leads 51 or 52 for selected energization of  
20 the electrodes 42.

The leads 51 and 52 include switching systems 53 added to selectively energize the electrodes 42.

The two or more electrodes 42 are each associated with and electrically  
insulated from the pipe tool 24 as in Figure 3 a, d, e and f and each are connected  
25 in circuit with the leads 51 or 52 for selected energization of the electrodes 42 as shown in Figure 3 a through j. The two or more electrodes are each movably connected in circuit with the leads 51 or 52 through a compliant electrical coupling 54 between the electrodes 42 and the leads 51 and 52 for energization of the electrodes 42 and for permitting ultrasonic vibration of the pipe tool 24, see Figure  
30 2. The two or more electrodes are each alternatively associated with the flue 17 as in Figure 3 b and g and are each connected in circuit with the leads 51 or 52 for selected energization of the electrodes 42. At least one of the electrodes 42 is associated with the flue 17 and at least one of the electrodes is associated with the

pipe tool 24 in an embodiment as in Figure 3 c and j. The electrodes 42 are each connected in circuit with the leads 51 or 52 for selected energization of the electrodes 42.

The one or more electrodes 42 associated with the pipe tool 24, in Figure 3 a, 5 d, e, and f are each in one configuration movably connected in circuit with its respective lead 51 or 52 through the compliant electrical coupling 54 as in Figure 2 between each of the electrode 42 and the lead 51 or 52 for energization of each electrode 42 and for permitting ultrasonic vibration of the pipe tool 24. The one or more electrodes 42 are each associated with and electrically insulated from the pipe tool 24 in e.g., Figure 3 10 a, d, e and f. The one or more electrodes 42 are each connected in circuit with one of the leads 51 or 52 and the pipe tool 24 is connected in circuit with the other of the leads 51 or 52 for allowing selected energization of the electrodes 42. The one or more electrodes 42 associated with the pipe tool 24 are each movably connected in circuit with their respective lead 51 or 52 through the compliant electrical coupling 54 as in 15 Figure 2 between the electrodes and the lead for energization of the electrodes 42 while permitting ultrasonic vibration of the pipe tool 24.

The two or more electrodes 42 are each associated with the pipe tool 24 by being carried on the outside thereof in Figure 3 a for extending from the housing 11 end thereof to the distal tip 18. The two or more electrodes 42 are each in another 20 arrangement associated with the pipe tool 24 by being carried on the inside thereof in Figure 3 e for extending from the housing 11 end thereof to the distal tip 18. The two or more electrodes 42 are each associated in a different approach with the pipe tool 24 having at least one carried on the inside thereof and at least one carried on the outside thereof in Figure 3 f for extending from the housing 11 end thereof to the distal 25 tip 18. The two or more electrodes 42 are each associated with the flue 17 in still another way by being carried on the outside thereof in Figure 3 b for extending from the housing 11 support thereof distally. The two or more electrodes 42 are each associated with the flue 17 by being carried alternately on the inside thereof in Figure 3 g for extending from the housing 11 support thereof distally. The two or more 30 electrodes 42 are each associated with the flue 17 having at least one carried on the inside thereof and at least one carried on the outside thereof in Figure 3 h another embodiment for extending from the housing 11 support thereof distally.

The two or more electrodes are each associated with the pipe tool 24 having at least one carried on the inside thereof and at least one carried on the outside thereof in Figure 3 f for extending from the housing 11 end thereof to the distal tip 18 in still another arrangement. The two or more electrodes 42 are respectively  
5 associated with the flue 17 and the pipe tool 24 by being carried on the outside of each in Figure 3 c for extending from the housing 11 distally to permit yet a further form of bipolar electrosurgery with ultrasonic vibration.

The two or more electrodes 42 are respectively associated with the flue 17 and pipe tool 24 by being carried on the inside of each in Figure 3 i for extending  
10 from the housing 11 support thereof distally. The two or more electrodes 42 are respectively associated with the flue 17 and the pipe tool 24 by having at least one carried on the inside of either the flue 17 or the pipe tool 24 and at least one carried on the outside of the pipe tool 24 or the flue 17 for extending from the housing 11 support thereof distally and having at least a bipolar circuit between the outside of  
15 one and the inside of the other as in any of the Figures 3 c, i and j.

A method of using a bipolar ultrasonic surgical instrument includes a handpiece for manipulation by a surgeon. Generating a source of bipolar electrosurgical radio frequency energy is a step. Driving with an electronic oscillator 46 an ultrasonic instrument at a predetermined frequency is a step. Setting a level  
20 of ultrasonic vibration with an ultrasonic driving circuit is a step. Holding a housing for the handpiece during use is a step. Connecting leads 51 or 52 the bipolar source 49 of electrosurgical radio frequency energy is a step. Enclosing and positioning a transducer 12 within the housing 11 along an axis thereof for oscillating the transducer 12 along the axis with motion sufficient for ultrasonic surgery at around  
25 at least one preferred frequency and wavelength is a step. Oscillating a pipe tool 24 attached to the transducer 12 so that each pipe tool 24 oscillates around at least one preferred frequency and wavelength is a step. Connecting the central bore 22 passing through each pipe tool 24 to a source of aspiration is a step. Positioning the distal tip 18 on the pipe tool 24 away from the housing 11 for ultrasonic, bipolar  
30 electrosurgery or a combination thereof is a step. Disposing a flue 17 coaxially about the pipe tool 24 the flue 17 supported for cantilever extension from the housing 11 is a step. Passing irrigating fluid through an annular space between the pipe tool 24 and the flue 17 is a step. Connecting two or more electrodes 42 associated with the

pipe tool 24, flue 17 or either of them in circuit with the leads for energization of the electrodes 42 with radio frequency energy is a step.

While various arrangements have been shown in the figures and described by way of example, the claims that follow seek to cover all embodiments that permit  
5 ultrasonic surgery and bipolar electro-surgery in any combination or method.



5

**What is claimed is:**

1. A bipolar ultrasonic surgical instrument including a handpiece for manipulation by a surgeon comprising:
- 10 a bipolar source 49 of electrosurgical radio frequency energy;
  - an electronic oscillator 46 for driving the ultrasonic instrument at a predetermined frequency;
  - an ultrasonic driving circuit 50 for permitting setting of the level of the ultrasonic vibration;
  - 15 a housing 11 for holding the handpiece, the housing 11 held proximally by the surgeon during use;
  - leads 51 or 52 connected to the bipolar source 49 of electrosurgical radio frequency energy and carried by the housing 11;
  - a transducer 12 enclosed within the housing 11, positioned along an axis thereof and selected for oscillating along the axis with motion sufficient for 20 ultrasonic surgery at around at least one preferred frequency and wavelength;
  - pipe tools 24 each attachable to the transducer 12 so that each pipe tool 24 oscillates around at least one preferred frequency and wavelength;
  - a central bore 22 passing through each pipe tool 24 and connected to a source of aspiration 53;
  - 25 a distal tip 18 on the pipe tool 24 positioned away from the housing 11 in position for ultrasonic, bipolar electrosurgery or a combination thereof;
  - a flue 17 coaxially disposed about the pipe tool 24 and supported for cantilever extension from the housing 11;
  - an annular space 33 between the pipe tool 24 and the flue 17 for 30 passage of irrigating fluid, and
  - two or more electrodes 42 associated with the pipe tool 24, flue 17 or either of them and connected in circuit with the leads 51 or 52 for energization of the electrodes 42 with radio frequency energy.
2. The bipolar ultrasonic surgical instrument of Claim 1 wherein the leads 35 51 or 52 include switching systems added for selected energization by the surgeon of the electrodes 42.

3. The bipolar ultrasonic surgical instrument of Claim 1 wherein the ultrasonic driving circuit 50 has an amplitude control 47 connected to the electronic oscillator 46, a frequency regulator 48 between the amplitude control 47 and the electronic oscillator 46 and a frequency control feedback loop in the frequency  
5 regulator 48 for maintaining the linear dynamics of the ultrasonic surgical instrument about the predetermined frequency.

4. The bipolar ultrasonic surgical instrument of Claim 1 wherein the two or more electrodes 42 are each associated with and electrically insulated from the pipe tool 24 and are connected in circuit with the leads 51 or 52 for selected  
10 energization of the electrodes 42.

5. The bipolar ultrasonic surgical instrument of Claim 4 wherein the two or more electrodes 42 are each movably connected and in circuit with the leads 51 or 52 through a sliding electrical coupling 54 between the electrodes 42 and the leads 51 or 52 for energization of the electrodes 42 and for permitting ultrasonic  
15 vibration of the pipe tool 24.

6. The bipolar ultrasonic surgical instrument of Claim 1 wherein the two or more electrodes 42 are each associated with the flue 17 and are connected in circuit with the leads 51 or 52 for energization of the electrodes 42 with radio frequency energy.

20 7. The bipolar ultrasonic surgical instrument of Claim 1 wherein at least one of the electrodes 42 is associated with the flue 17 and at least one of the electrodes 42 is associated with the pipe tool 24 and the electrodes 42 are connected in circuit with the leads 51 or 52 for energization of the electrodes 42 with radio frequency energy.

25 8. The bipolar ultrasonic surgical instrument of Claim 7 wherein the one or more electrodes 42 associated with the pipe tool 24 are each movably connected in circuit with its respective lead through a sliding electrical coupling 54 between the electrode and its lead for energization with radio frequency energy of the electrode and for permitting ultrasonic vibration of the pipe tool 24.

30 9. The bipolar ultrasonic surgical instrument of Claim 1 wherein the one or more electrodes 42 are associated with and electrically insulated from the pipe tool 24, the one or more electrodes 42 are each connected in circuit with one of the leads 51 or 52 and the pipe tool 24 is connected in circuit with the other of the leads

51 or 52 for allowing energization with radio frequency energy of the electrodes 42 by the surgeon.

10. The bipolar ultrasonic surgical instrument of Claim 9 wherein the one or more electrodes 42 associated with the pipe tool 24 are each movably connected  
5 in circuit with their respective lead through a sliding electrical coupling 54 between the electrodes 42 and its lead for energization with radio frequency energy of the electrodes 42 and for permitting ultrasonic vibration of the pipe tool 24.

11. The bipolar ultrasonic surgical instrument of Claim 4 wherein the two or more electrodes 42 are each associated with the pipe tool 24 by being carried on  
10 the outside thereof for extending from the housing 11 end thereof to the distal tip.

12. The bipolar ultrasonic surgical instrument of Claim 4 wherein the two or more electrodes 42 are each associated with the pipe tool 24 by being carried on the inside thereof for extending from the housing 11 end thereof to the distal tip 18.

13. The bipolar ultrasonic surgical instrument of Claim 4 wherein the two  
15 or more electrodes 42 are each associated with the pipe tool 24 having at least one carried on the inside thereof and at least one carried on the outside thereof for extending from the housing 11 end thereof to the distal tip 18.

14. The bipolar ultrasonic surgical instrument of Claim 6 wherein the two or more electrodes 42 are each associated with the flue 17 by being carried on the  
20 outside thereof for extending from the housing 11 support thereof distally.

15. The bipolar ultrasonic surgical instrument of Claim 6 wherein the two or more electrodes 42 are each associated with the flue 17 by being carried on the inside thereof for extending from the housing 11 support thereof distally.

16. The bipolar ultrasonic surgical instrument of Claim 6 wherein the two  
25 or more electrodes 42 are each associated with the flue 17 having at least one carried on the inside thereof and at least one carried on the outside thereof for extending from the housing 11 support thereof distally.

17. The bipolar ultrasonic surgical instrument of Claim 6 wherein the two or more electrodes 42 are each associated with the pipe tool 24 having at least one  
30 carried on the inside thereof and at least one carried on the outside thereof for extending from the housing 11 end thereof to the distal tip 18.

18. The bipolar ultrasonic surgical instrument of Claim 7 wherein the two or more electrodes 42 are respectively associated with the flue 17 and the pipe tool

24 by being carried on the outside of each for extending from the housing 11 distally.

19. The bipolar ultrasonic surgical instrument of Claim 7 wherein the two or more electrodes 42 are respectively associated with the flue 17 by being carried  
5 on the inside of each for extending from the housing 11 support thereof distally.

20. The bipolar ultrasonic surgical instrument of Claim 7 wherein the two or more electrodes 42 are respectively associated with the flue 17 having at least one carried on the inside of either the flue 17 or the pipe tool 24 and opposite thereto at least one carried on the outside of the pipe tool 24 or the flue 17 for  
10 extending from the housing 11 support thereof distally and having at least a bipolar circuit between the outside of one and the inside of the other.

21. A method of using a bipolar ultrasonic surgical instrument including a handpiece for manipulation by a surgeon having the steps of:

generating a source of bipolar electrosurgical radio frequency energy;  
15 driving with an electronic oscillator 46 an ultrasonic instrument at a predetermined frequency;

setting a level of ultrasonic vibration with an ultrasonic driving circuit  
50;

holding a housing 11 for the handpiece during use;  
20 connecting leads 51 or 52 the bipolar source 49 of electrosurgical radio frequency energy;

enclosing and positioning a transducer 12 within the housing 11 along an axis thereof for oscillating the transducer 12 along the axis with motion sufficient for ultrasonic surgery at around at least one preferred frequency and wavelength;

25 oscillating a pipe tool 24 attached to the transducer 12 so that each pipe tool 24 oscillates around at least one preferred frequency and wavelength;

connecting a central bore 22 passing through each pipe tool 24 to a source of aspiration 53;

30 positioning a distal tip 18 on the pipe tool 24 away from the housing 11 for ultrasonic, bipolar electrosurgery or a combination thereof;

disposing a flue 17 coaxially about the pipe tool 24 and supported for cantilever extension from the housing 11;

passing irrigating fluid through an annular space 33 between the pipe tool 24 and the flue 17, and

connecting two or more electrodes 42 associated with the pipe tool 24, flue 17 or either of them in circuit with the leads 51 or 52 for energization of the  
5 electrodes 42 with radio frequency energy.

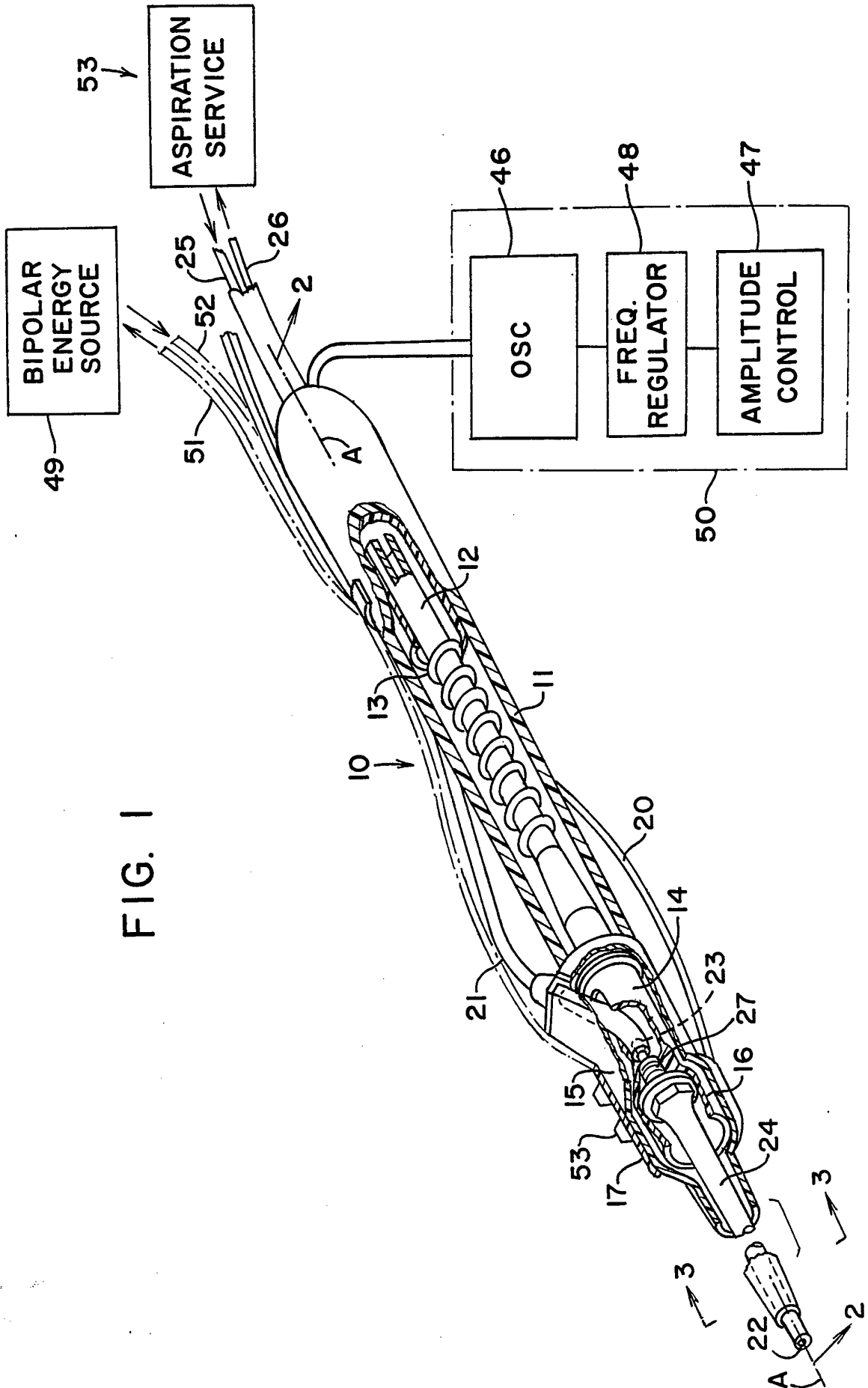

FIG. 1

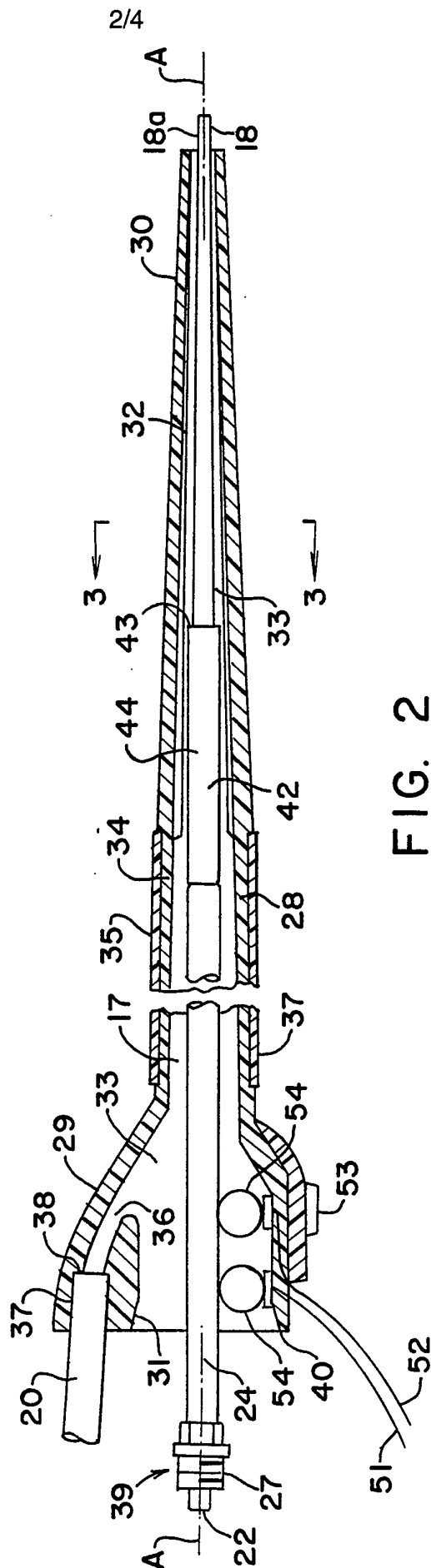
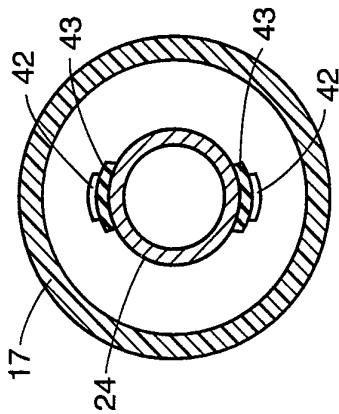
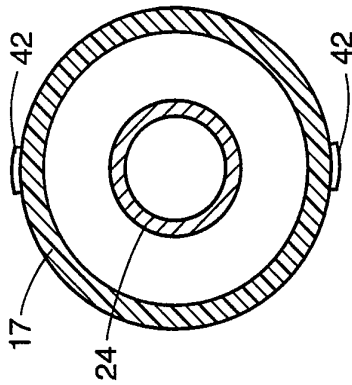

FIG. 2

**FIG. 3A**



**FIG. 3B**



**FIG. 3C**

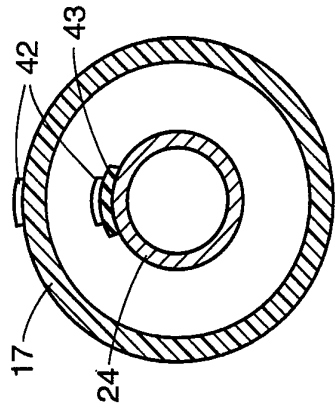

**FIG. 3D**

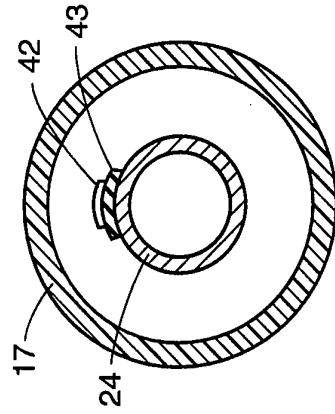

**FIG. 3E**

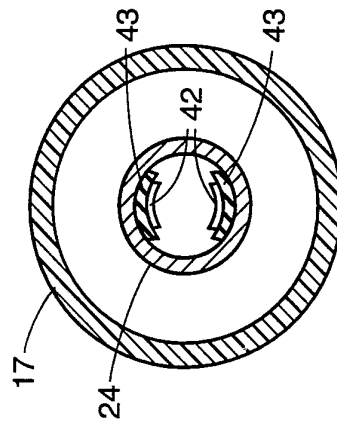

**FIG. 3F**

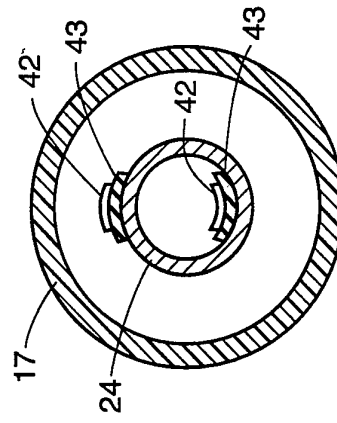

**FIG. 3G**

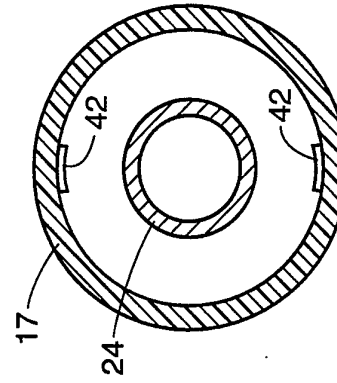

**FIG. 3H**

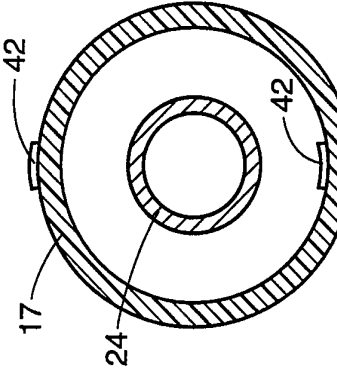



FIG. 3I

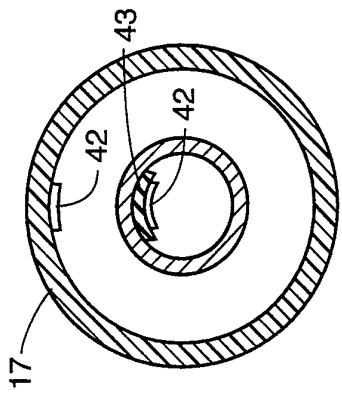

FIG. 3J

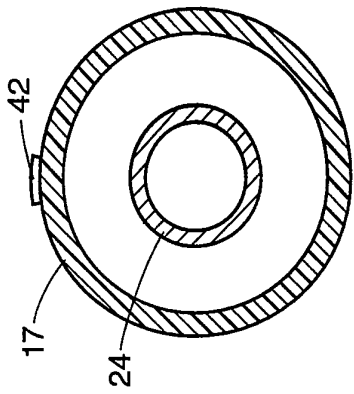
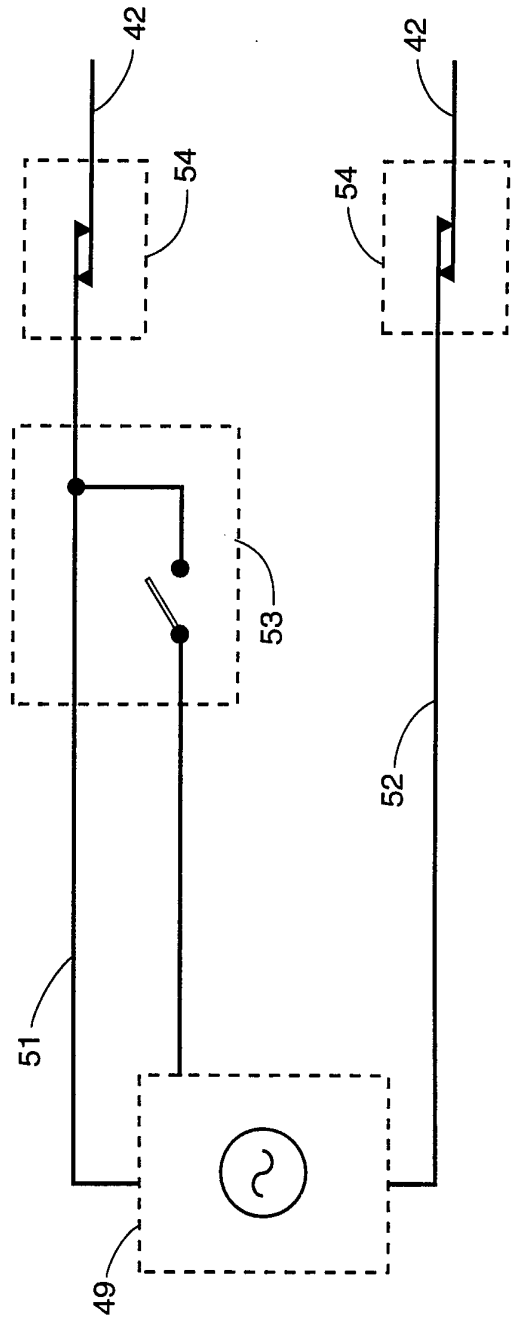

FIG. 4



# INTERNATIONAL SEARCH REPORT

International Application No

PCT/IB 94/00332

**A. CLASSIFICATION OF SUBJECT MATTER**  
 IPC 6 A61B17/32 A61B17/39

According to International Patent Classification (IPC) or to both national classification and IPC

**B. FIELDS SEARCHED**

Minimum documentation searched (classification system followed by classification symbols)  
 IPC 6 A61B A61F

Documentation searched other than minimum documentation to the extent that such documents are included in the fields searched

Electronic data base consulted during the international search (name of data base and, where practical, search terms used)

**C. DOCUMENTS CONSIDERED TO BE RELEVANT**

Category *	Citation of document, with indication, where appropriate, of the relevant passages	Relevant to claim No.
A	US,A,4 931 047 (BROADWIN) 5 June 1990 cited in the application ---	1,22
P,A	US,A,5 312 329 (BEATY) 17 May 1994 see abstract; figure 3 ---	1,21
A	US,A,4 936 281 (STASZ) 26 June 1990 see column 3, line 41 - line 58; figure 5 -----	1

Further documents are listed in the continuation of box C.

Patent family members are listed in annex.

\* Special categories of cited documents :

- "A" document defining the general state of the art which is not considered to be of particular relevance
- "E" earlier document but published on or after the international filing date
- "L" document which may throw doubts on priority claim(s) or which is cited to establish the publication date of another citation or other special reason (as specified)
- "O" document referring to an oral disclosure, use, exhibition or other means
- "P" document published prior to the international filing date but later than the priority date claimed

- "T" later document published after the international filing date or priority date and not in conflict with the application but cited to understand the principle or theory underlying the invention
- "X" document of particular relevance; the claimed invention cannot be considered novel or cannot be considered to involve an inventive step when the document is taken alone
- "Y" document of particular relevance; the claimed invention cannot be considered to involve an inventive step when the document is combined with one or more other such documents, such combination being obvious to a person skilled in the art.
- "&" document member of the same patent family

Date of the actual completion of the international search

Date of mailing of the international search report

1 February 1995

15.02.95

Name and mailing address of the ISA

European Patent Office, P.B. 5818 Patentlaan 2  
 NL - 2280 HV Rijswijk  
 Tel. (+31-70) 340-2040, Tx. 31 651 epo nl,  
 Fax: (+31-70) 340-3016

Authorized officer

Papone, F

# INTERNATIONAL SEARCH REPORT

Information on patent family members

International Application No  
PCT/IB 94/00332

Patent document cited in search report	Publication date	Patent family member(s)	Publication date
US-A-4931047	05-06-90	AT-T- 113457	15-11-94
		AU-B- 616699	07-11-91
		AU-A- 2538288	18-04-89
		DE-D- 3852005	08-12-94
		EP-A- 0310431	05-04-89
		JP-T- 2501894	28-06-90
		WO-A- 8902725	06-04-89
		US-A- 5015227	14-05-91
US-A-5312329	17-05-94	AU-B- 6030194	24-10-94
		FI-A- 941573	08-10-94
		WO-A- 9422378	13-10-94
US-A-4936281	26-06-90	NONE	