

M. T. BENTLEY.  
STOP MOTION FOR SPINNING MACHINES.

APPLICATION FILED AUG. 12, 1903.

NO MODEL.

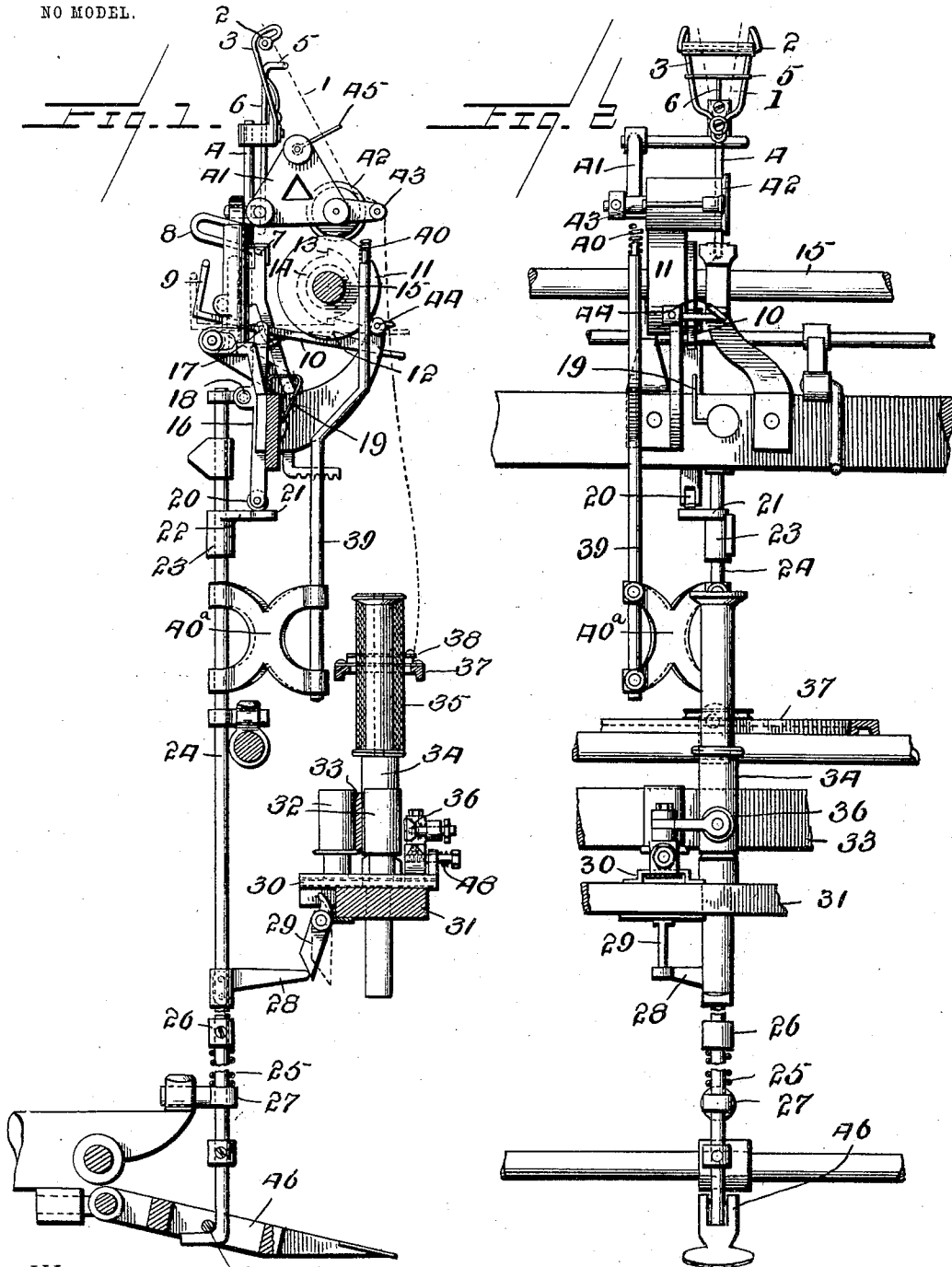

WITNESSES:  
*W. F. Doyle.*  
*J. W. Riley*

INVENTOR  
*Manton T. Bentley.*  
 BY  
*Rexford M. Smith*  
 Attorney

# UNITED STATES PATENT OFFICE.

MANTON T. BENTLEY, OF YORK, PENNSYLVANIA, ASSIGNOR OF ONE-HALF TO YORK SILK MANUFACTURING COMPANY, OF YORK, PENNSYLVANIA.

## STOP-MOTION FOR SPINNING-MACHINES.

SPECIFICATION forming part of Letters Patent No. 774,149, dated November 8, 1904.

Application filed August 12, 1903. Serial No. 169,267. (No model.)

*To all whom it may concern:*

Be it known that I, MANTON T. BENTLEY, a citizen of the United States, residing at York, in the county of York and State of Pennsylvania, have invented a certain new and useful Stop-Motion for Spinning-Machines, of which the following is a specification, reference being had therein to the accompanying drawings.

In the working of silk or other yarns it is often necessary to double two or more continuous threads together in order to get a finished thread of the required size and construction. This is accomplished by passing the single threads from any number of spools required over properly constructed and arranged guides and bringing the same together on another spool or bobbin, termed the "take-up" bobbin, which may be revolved at the same time, thereby twisting the threads together. In order to insure a continuous thread from each of the primary spools, some means must be provided for stopping the motion of the take-up bobbin as well as all the other spools whenever a thread breaks or the spool runs empty, thereby giving the operator time to piece or tie up the broken ends, so that the spools may again be set in motion.

The object of the present invention is to provide simple, reliable, and effective mechanism for the purpose above described which is positive in action and which will enable the broken thread or threads to be reunited and the machine again put in operation.

With the above and other objects in view, the nature of which will more fully appear as the description proceeds, the invention consists in the novel construction, combination, and arrangement of parts, as hereinafter fully described, illustrated, and claimed.

In the accompanying drawings, Figure 1 is a vertical cross-section through a spinning or doubling machine, showing the present invention applied thereto. Fig. 2 is a front elevation of a portion of the machine sufficient to illustrate the nature and operation of the present invention.

Like reference-numerals designate corre-

sponding parts in both figures of the drawings.

The threads 1, coming from any suitable source, such as the primary spools or bobbins, pass over a carrier-bar 2 at or near the top of the machine, the carrier-bar being supported by a bracket 3, in turn supported upon a post or standard 4, extending upward from the machine-frame. The threads then pass through the eyes 5 of a series of faller-wires 6, pivotally mounted at 7 on the machine-frame and provided adjacent to their pivotal points with offset extensions forming tailpieces 8, which project rearwardly, as shown in Fig. 1, and lie immediately over, but normally out of contact with the upturned heel extensions 9 of a series of knock-off levers 10, which extend forward beneath the drive-roll 11. Each of the knock-off levers 10 is provided adjacent to its outer end with a catch lip or shoulder 12, which is adapted to move into and out of engagement with one or more shoulders 13, formed on a trip-collar 14, fast on the shaft or axle 15 of the drive-roll 11, as indicated by dotted lines in Fig. 1. In case the thread 1 breaks, the faller-wire 6 drops backward, bringing the tailpiece 8 into engagement with the extension 9 of the knock-off lever. This rocks the lever 10 on its fulcrum, and being fulcrumed intermediate its ends the catch-lip 12 is moved upward into engagement with one of the shoulders 13 on the revolving trip-collar 14. In the rotation of the trip-collar, and by reason of the engagement between the shoulders 12 and 13, the knock-off lever is moved outward, thereby swinging the trip-lever 16, upon the upper end of which the knock-off lever is fulcrumed, as shown at 17.

The knock-off lever 16 extends substantially in a vertical direction and is fulcrumed intermediate its ends at 18 on the machine-frame, while the upper arm of the lever is acted upon by a trip-lever spring 19, which acts to hold the said upper portion of the lever rearward and keep a roller 20 at the lower end of said lever upon and in engagement with a foot or rest 21, forming an L-shaped extension of

an arm 22, extending outward from a sleeve 23, mounted fast upon and movable with a vertical reciprocatory rod 24. When the trip-lever 16 is vibrated by the means above described, so as to move the roller 20 out of engagement with the foot or rest 21, the lift-rod 24 is released and at once moves upward by reason of the tension of an expansion-spring 25, which is interposed between a shoulder or collar 26, fast on the lift-rod, and a bearing on the machine-frame, through which said lift-rod slides. At a suitable point the lift-rod 24 is provided with a laterally-extending tappet 28, which in the upward movement of the lift-rod comes in contact with and operates a shifter-lever 29. The lever 29 operates a slide 30, mounted on one of the machine-rails 31 and carrying a pair of belt-guide pulleys 32, between which runs a driving-belt 33, which operates the spindles 34 of the take-up bobbins 35, upon which the thread or threads 1 are wound. The belt-shifting device now being described is also equipped with a brake 36, more particularly described in a copending application, so that when the slide 30 is moved by the lever 29 the driving-belt 33 is shifted out of driving contact with the spindles 34, and at the same time brake-shoes are brought into contact with the spindles, thereby bringing the latter to a stop and stopping the winding of the thread upon the spindles.

37 designates the ring-rail of the machine, which moves up and down along the length of the bobbins 35, and 38 designates one of the travelers connected with the ring-rail and encircling the bobbin for distributing the thread thereon and guiding the same thereto.

Movable with the lift-rod 24 is a feed-roll lift-rod 39, the same being connected rigidly with the rod 24 by means of a coupling or bracket 40<sup>a</sup>, of any suitable description. At its upper end the rod 39 is provided with a buffer-spring 40, which, as the rod 39 moves upward, is brought into contact with a portion of the feed-roll frame 41, the result being that the feed-roll 42 carried by said frame is raised out of contact with the driving-roll 11, and as the feed-roll 42 draws the threads from the primary spools it will be seen that the feed of the threads will be stopped as soon as said feed-roll is moved out of contact with the drive-roll. The threads or thread 1, after passing through the eyes of the faller-wires, are brought together by a gathering-guide 45, at the top of the feed-roll frame 41, and are wrapped once around the feed-roll 42 and then carried outward over a guide or carrier roll 43, thence downward through a guide-eye 44, suitably supported on the machine-frame, and from thence to the traveler 38 on the ring-rail 37, where the compound thread is twisted and wound upon a take-up bobbin 35.

46 designates the foot-lever, which is connected at 47 with the lower end of the lift-rod

24. After mending the broken thread or threads the operator depresses the foot-lever 46, drawing down the foot piece or rest 21, so that the trip-lever 16 may swing back to its normal position, carrying the roller 20 in engagement with the foot piece or rest 21, when the machine is again in readiness for operation.

In the operation of the machine when a thread breaks or a spool runs empty the faller-wire, through the eye of which the thread passes, is released and falls backward, bringing the tailpiece thereof in contact with the extension of the knock-off lever. This raises the opposite end of the lever and throws said lever into engagement with the shouldered collar on the shaft of the drive-roll, the latter acting to carry the knock-off lever forward. This has the effect of rocking the trip-lever and moving the roller 20 out of engagement with the foot or rest 21, thereby releasing the lift-rod 24, which is moved upward by the action of the spring 25. As the lift-rod moves upward it acts upon the shifter-lever 29, and thereby shifts the driving-belt out of engagement with the spindles and at the same time applies the brakes to the spindles, stopping the latter. In its upward movement the lift-rod 24 also raises the feed-roll lift-rod 39 and swings the feed-roll frame and feed-roll upward, carrying the latter out of engagement with the drive-roll and stopping its revolution and the feed of the threads. The lift-rod 24 may carry any number of tappets for operating the different parts. The buffer-spring 40, at the upper end of the feed-roll lift-rod, relieves any sudden blow against the feed-roll frame when quickly released. In again starting the operator pieces or ties the broken ends, replaces the threads in the eye of the drop-wire, thereby holding the latter in upright position, and otherwise properly places the thread, as previously explained. He then depresses the foot-lever 46, which carries the lift-rod 24 downward, compressing the spring 25, releasing the tappet 28 from the shifter-lever 29, when by the action of the shifter slide-spring (shown at 48) the driving-belt 33 is carried back into driving engagement with the spindles. In the same downward movement of the lift-rod 24 the trip-lever foot or rest 21 is also depressed to enable the trip-lever spring 19 to force the trip-lever 16 and knock-off lever 10 back to their original positions. At the same time the feed-roll lift-rod 39 is moved downward, dropping the feed-roll 42 into engagement with the drive-roll, whereby it is again set in motion and the feed of the threads resumed.

It will be apparent that the construction hereinabove described is susceptible of various changes in the form, proportion, and minor details, which may be accordingly resorted to without departing from the principle or sacrificing any of the advantages of the invention.

Parts of the machine not hereinabove described may be constructed and arranged in any usual or preferred manner.

Having thus described the invention, what I claim as new is—

1. In stop mechanism for spinning-machines and the like, the combination of a vertically-movable upwardly-pressed lift-rod, a foot-piece on said rod, a trip-lever arranged to engage the foot-piece and to hold said rod depressed, a knock-off lever connected with the trip-lever, a faller-wire acting directly on the knock-off lever to rock the same, a rotary shaft provided with means for engaging the knock-off lever, and means controlled by the lift-rod for throwing the spindles and feed-roll out of operation.

2. In stop mechanism for spinning-machines and the like, a spring-elevated lift-rod, a foot-piece on said rod, a trip-lever engaging the foot-piece to hold the rod down, a knock-off lever connected with the trip-lever and adapted to be shifted by the drive-roll shaft, means adapted upon the breakage of a thread to actuate the knock-off lever and throw the same into engagement with the drive-roll shaft, and means controlled by the lift-rod when released for throwing the machine out of operation.

3. In stop mechanism for spinning-machines and the like, a spring-elevated lift-rod, a foot-piece on said rod, a trip-lever engaging the foot-piece to hold the rod down, a knock-off lever fulcrumed on the trip-lever and adapted to be shifted by the drive-roll shaft, a faller-wire adapted upon the breakage of a thread to actuate the knock-off lever and throw the same into engagement with the drive-roll shaft, and means controlled by the lift-rod when released for throwing the machine out of operation.

4. In stop mechanism for spinning-machines and the like, a spring-elevated lift-rod, a foot-piece on said rod, a trip-lever for holding said rod down, a spring for holding the trip-lever in engagement with the foot-piece on the lift-rod, a knock-off lever fulcrumed on the trip-lever and adapted to be engaged by a shoulder on the drive-roll shaft, a faller-wire adapted upon the breakage of a thread to throw the knock-off lever into engagement with said shoulder, and means controlled by the lift-rod when released for throwing the machine out of operation.

5. In stop mechanism for spinning-machines and the like, a spring-elevated lift-rod, a foot-piece or rest thereon, a vertically-disposed trip-lever having its lower end in engagement with said foot-piece, a knock-off lever fulcrumed on the upper end of said trip-lever and provided with a catch-lip, a shouldered collar on the drive-roll shaft, a faller-wire adapted on the breakage of a thread to swing the knock-off lever into engagement with the shouldered collar, and means controlled by

the lift-rod when released for throwing the machine out of operation.

6. In stop mechanism for spinning-machines and the like, a spring-elevated lift-rod, a trip-lever for holding the lift-rod down, a knock-off lever fulcrumed on the trip-lever and adapted to be shifted by the driving-roll, a shoulder on the drive-roll shaft, a faller-wire adapted upon the breakage of a thread to move the knock-off lever into engagement with the shoulder on the drive-roll shaft, a swinging feed-roll frame, a feed-roll carried thereby and resting in contact with the drive-roll, and a feed-roll lift-rod connected with the first-named lift-rod and adapted to act on the feed-roll frame for lifting the feed-roll out of engagement with the drive-roll.

7. In stop mechanism for spinning-machines and the like, a spring-elevated lift-rod, a foot-piece thereon, a trip-lever engaging said foot-piece for holding said rod down, a knock-off lever fulcrumed on the trip-lever, a faller-wire adapted upon the breakage of a thread to swing the knock-off lever, a drive-roll, a feed-roll frame, a feed-roll carried thereby, a feed-roll lift-rod offset to one side of the main lift-rod and carried thereby, and a buffer-spring connected with the feed-roll lift-rod and adapted to contact with the feed-roll frame when the main lift-rod is released.

8. In stop mechanism for spinning-machines and the like, a spring-elevated lift-rod, a foot-piece thereon, a foot-lever for depressing said rod, a vertically-disposed trip-lever for holding the rod depressed, a spring for maintaining said trip-lever in engagement with the foot-piece on the lift-rod, a knock-off lever fulcrumed on one arm of the trip-lever and shiftable therewith, a shouldered collar mounted on a rotary shaft and adapted to engage a shoulder or lip on the knock-off lever, a faller-wire provided with a tailpiece adapted to act upon the knock-off lever and throw the latter into engagement with said shouldered collar, and means controlled by the lift-rod when released for throwing the machine out of operation.

9. In stop mechanism for spinning-machines and the like, a spring-elevated lift-rod, a trip-lever for holding said rod depressed, a knock-off lever fulcrumed on the trip-lever and adapted to be shifted by one of the rotary shafts of the machine, a faller-wire adapted upon the breakage of a thread to throw the knock-off lever into engagement with such shaft, a series of spindles, a driving-belt for said spindles, a belt-shifter for moving the belt into and out of engagement with the spindles, a shifter-lever, and a tappet on the lift-rod for throwing the shifter-lever when the lift-rod is released.

10. In stop mechanism for spinning-machines, and the like, a spring-elevated lift-rod, a trip-lever acting directly on said rod for holding the same depressed, a knock-off lever

connected with the trip-lever and provided  
with a catch or shoulder and also provided  
with an upward extension at one end, a rotary  
shaft provided with means for engaging the  
5 shoulder on the knock-off lever, a faller-wire  
provided intermediate its ends with an offset or  
tailpiece adapted to cooperate with the up-  
ward extension of the knock-off lever for mov-  
ing the latter into engagement with said shaft,  
10 the lever extension being adapted to slide

against the tailpiece of the faller-wire, and  
means controlled by the lift-rod when released  
for throwing the machine out of operation.

In testimony whereof I affix my signature in  
presence of two witnesses.

MANTON T. BENTLEY.

Witnesses:

J. E. PHILLIPS,

J. HARRY WOOLRIDGE.