



- (51) **International Patent Classification:**  
*H04N 19/13* (2014.01)
- (21) **International Application Number:**  
PCT/CN2020/071591
- (22) **International Filing Date:**  
11 January 2020 (11.01.2020)
- (25) **Filing Language:** English
- (26) **Publication Language:** English
- (30) **Priority Data:**  
62/791,674 11 January 2019 (11.01.2019) US
- (71) **Applicant: HUAWEI TECHNOLOGIES CO., LTD.**  
[CN/CN]; Huawei Administration Building, Bantian, Long-gang District, Shenzhen, Guangdong 518129 (CN).
- (72) **Inventors: GAO, Han;** Riesstr. 25, 80992 Munich (DE). **CHEN, Jianle;** 2330 Central Expressway, Santa Clara, California 95050 (US). **ESENLIK, Semih;** Riesstr. 25, 80992 Munich (DE). **KOTRA, Anand Meher;** Riesstr. 25, 80992 Munich (DE). **WANG, Biao;** Riesstr. 25, 80992 Munich (DE).
- (81) **Designated States** (*unless otherwise indicated, for every kind of national protection available*): AE, AG, AL, AM,

AO, AT, AU, AZ, BA, BB, BG, BH, BN, BR, BW, BY, BZ, CA, CH, CL, CN, CO, CR, CU, CZ, DE, DJ, DK, DM, DO, DZ, EC, EE, EG, ES, FI, GB, GD, GE, GH, GM, GT, HN, HR, HU, ID, IL, IN, IR, IS, JO, JP, KE, KG, KH, KN, KP, KR, KW, KZ, LA, LC, LK, LR, LS, LU, LY, MA, MD, ME, MG, MK, MN, MW, MX, MY, MZ, NA, NG, NI, NO, NZ, OM, PA, PE, PG, PH, PL, PT, QA, RO, RS, RU, RW, SA, SC, SD, SE, SG, SK, SL, ST, SV, SY, TH, TJ, TM, TN, TR, TT, TZ, UA, UG, US, UZ, VC, VN, WS, ZA, ZM, ZW.

- (84) **Designated States** (*unless otherwise indicated, for every kind of regional protection available*): ARIPO (BW, GH, GM, KE, LR, LS, MW, MZ, NA, RW, SD, SL, ST, SZ, TZ, UG, ZM, ZW), Eurasian (AM, AZ, BY, KG, KZ, RU, TJ, TM), European (AL, AT, BE, BG, CH, CY, CZ, DE, DK, EE, ES, FI, FR, GB, GR, HR, HU, IE, IS, IT, LT, LU, LV, MC, MK, MT, NL, NO, PL, PT, RO, RS, SE, SI, SK, SM, TR), OAPI (BF, BJ, CF, CG, CI, CM, GA, GN, GQ, GW, KM, ML, MR, NE, SN, TD, TG).

**Published:**  
— with international search report (Art. 21(3))

(54) **Title:** ENCODER, DECODER AND CORRESPONDING METHODS USING DCT2 ENABLED HIGH LEVEL FLAG

FIG. 8

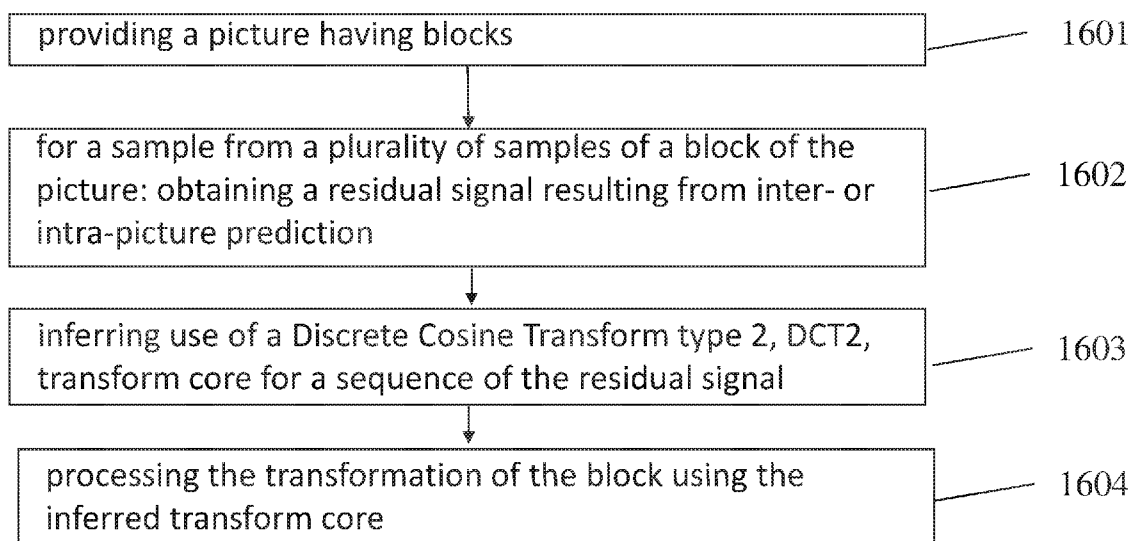

(57) **Abstract:** A method of video coding a block of a picture includes: obtaining a residual signal resulting from inter-or intra-picture prediction; inferring use of a DCT2 transform core for a sequence of the residual signal; processing the transformation of the block using the inferred transform core.

WO 2020/143811 A1

ENCODER, DECODER AND CORRESPONDING METHODS USING DCT2 ENABLED  
HIGH LEVEL FLAG

**CROSS-REFERENCE TO RELATED APPLICATIONS**

- 5 This patent application claims priority of U.S. Provisional Patent Application No. 62/791,674, filed January 11, 2019, the disclosure of the aforementioned patent application is hereby incorporated by reference in its entirety.

**TECHNICAL FIELD**

- 10 Embodiments of the present application (disclosure) generally relate to the field of picture processing and more particularly to the high level control of the transform type selection adaptive by block shape.

**BACKGROUND**

- 15 Video coding (video encoding and decoding) is used in a wide range of digital video applications, for example broadcast digital TV, video transmission over internet and mobile networks, real-time conversational applications such as video chat, video conferencing, DVD and Blu-ray discs, video content acquisition and editing systems, and camcorders of security applications.

20

- The amount of video data needed to depict even a relatively short video can be substantial, which may result in difficulties when the data is to be streamed or otherwise communicated across a communications network with limited bandwidth capacity. Thus, video data is generally compressed before being communicated across modern day telecommunications networks. The size of a video could also be an issue when the video is stored on a storage device because memory resources may be limited. Video compression devices often use software and/or hardware at the source to code the video data prior to transmission or storage, thereby decreasing the quantity of data needed to represent digital video images. The compressed data is then received at the destination by a video decompression device that
- 25
- 30 decodes the video data. With limited network resources and ever increasing demands of higher video quality, improved compression and decompression techniques that improve compression ratio with little to no sacrifice in picture quality are desirable.

In the JVET-L1001 the draft text of VVC draft 3.0, MTS can be enable in the sequence level for inter and intra slice individually. When the MTS is off, DCT2 is supposed to be used as transform core. However, in the prior art such as JVET-M0303, JVET-M0140 or JVET-M0102, inferred DST7/DCT8 transform is introduced. There is no possibility to switch to purely DCT2 transform for all case. The present disclosure addresses the above-mentioned problem.

10

In view of the above-discussed problems the present disclosure provides a solution to mitigate or even remove the above-mentioned problem.

Embodiments of the disclosure are defined by the features of the independent claims, and further advantageous implementations of the embodiments by the features of the dependent claims.

15 The present disclosure provides:

A method of video coding a block of a picture, comprising for a sample from a plurality of samples of the block:

- obtaining a residual signal resulting from inter- or intra-picture prediction;
- 20 inferring use of a Discrete Cosine Transform type 2, DCT2, transform core for a sequence of the residual signal;
- processing the transformation of the block using the inferred transform core.

That is, the present disclosure introduces an additional DCT2 enabled flag, which is used to infer whether only DCT2 transform core is used for all the case in the sequence, when DCT2 enabled flag is false, then the sequence level MTS enabled flag is further signaled. When DCT2 enabled flag is true, only DCT2 transform core is supposed to be used. Introducing additional DCT2 enabled flag in the SPS to make the switch to DCT2 possible when interred MST tool is on.

30

In a possible implementation form of the method according to the previous aspect as such, wherein use of DCT2 is inferred from a sequence level DCT2 enabled flag in the Sequence Parameter Set, SPS.

Thus, embodiments of the present disclosure introduce the switchable DCT2 enabled sequence level indicator, which provide the possibility to switch to pure DCT2 transform core with the inferred transform tool for the whole sequence or slice. DCT2 is relative simple to compute and low case for the memory bandwidth compare to other transform core. In the prior art, the possibility of using simple DCT2 transform is cut off by the inferred transform core, with the present indicator the flexibility of switching between low cost/complexity and high performance is provided for both encoder and decoder. In the embodiments, both low level changes and high level changes possibility is provided, which guarantee the consistency and coding performance of the code with multiple variations.

5

10

In a possible implementation form of the method according to the previous aspect as such, wherein the sequence level DCT2 enabled flag is denoted `sps_dct2_enabled_flag`.

In a possible implementation form of the method according to any preceding implementation of the previous two aspects or the previous aspect as such, wherein the sequence level DCT2 enabled flag is comprised in a SPS level syntax as follows:

15

	<b>Descriptor</b>
<code>seq_parameter_set_rbsp() {</code>	
<code>...</code>	<code>ue(v)</code>
<code>  sps_dct2_enabled_flag</code>	
<code>  if (! sps_dct2_enabled_flag) {</code>	
<code>    sps_mts_intra_enabled_flag</code>	<code>u(1)</code>
<code>    sps_mts_inter_enabled_flag</code>	<code>u(1)</code>
<code>  }</code>	
<code>  ...</code>	<code>u(1)</code>
<code>}</code>	

wherein `sps_dct2_enabled_flag` represents the sequence level DCT2 enabled flag.

20

In a possible implementation form of the method according to any preceding implementation of the previous aspect as such, wherein the `sps_mts_intra_enabled_flag` equal to 1 specifies that `tu_mts_flag` may be present in the residual coding syntax for intra coding units; `sps_mts_intra_enabled_flag` equal to 0 specifies that `tu_mts_flag` is not present in the residual coding syntax for intra coding units; and when the `sps_mts_intra_enabled_flag` is not present, the `sps_mts_intra_enabled_flag` is inferred to be 0.

25

In a possible implementation form of the method according to any preceding implementation

of the previous two aspects or the previous aspect as such, wherein the  
sps\_mts\_inter\_enabled\_flag specifies that tu\_mts\_flag may be present in the residual coding  
syntax for inter coding units; sps\_mts\_inter\_enabled\_flag equal to 0 specifies that  
tu\_mts\_flag is not present in the residual coding syntax for inter coding units; and when the  
5 sps\_mts\_intra\_enabled\_flag is not present, the sps\_mts\_intra\_enabled\_flag is inferred to be 0.

In a possible implementation form of the method according to any preceding implementation  
of the previous five aspects or the previous aspect as such,  
10 wherein the sequence level DCT2 enabled flag being equal to 1 specifies that DCT2  
transform core is used for transformation.

In a possible implementation form of the method according to any preceding implementation  
of the previous six aspects or the previous aspect as such,  
15 wherein the sequence level DCT2 enabled flag being equal to 1 specifies that DCT2  
transform core is used for transformation, only.

In a possible implementation form of the method according to any preceding implementation  
of the previous seven aspects or the previous aspect as such, wherein the sequence level  
DCT2 enabled flag being equal to 1 specifies that DCT2 is used for both horizontal as well as  
20 vertical direction transformation.

In a possible implementation form of the method according to any preceding implementation  
of the previous eight aspects or the previous aspect as such, wherein the sequence level DCT2  
enabled flag being equal to 1 specifies that DCT2 is used in sub block transformation.  
25

In a possible implementation form of the method according to the previous aspect as such,  
wherein in case one side of a residual Transform Unit, tu is greater than 32, a corresponding  
transform is set as DCT2.

30 In a possible implementation form of the method according to any preceding implementation  
of the previous ten aspects or the previous aspect as such, wherein in case the sequence level  
DCT2 enabled flag is equal to 1 specifies that the DCT2 transform core is used for  
transformation, only, both the sub block transform as well as Multiple Transform Selection,  
MTS, transform are inferred as off.

In a possible implementation form of the method according to any preceding implementation of the previous eleven aspects or the previous aspect as such,

5 wherein the sequence level DCT2 enabled flag being equal to 0 specifies that other transform cores than DCT2 are used for the transformation.

In a possible implementation form of the method according to the previous aspect as such,

10 wherein it is inferred using a Discrete Sine Transform type 7, DST7 and/or a Discrete Cosine Transform type 8, DCT8, for transformation.

In a possible implementation form of the method according to any preceding implementation of the two previous aspects or the previous aspect as such, wherein the sequence level DCT2 enabled flag being equal to 0

15 specifies that it is inferred using DST7/DCT8 for transformation, only.

DCT2 may be well desirable for both encoder and decoder design. In other word, the switchability between DCT2, inferred DST7 or DCT8 and MTS (RDO selected transform core) is one of the goals of the present disclosure.

20 In a possible implementation form of the method according to any preceding implementation of the three previous aspects or the previous aspect as such,

25 wherein in case the sequence level DCT2 enabled flag being equal to 0, it is determined whether Multiple Transform Selection for Sequence Parameter Set is enabled via a flag.

In a possible implementation form of the method according to the previous aspect as such;

wherein in case the `sps_mts_intra_enabled_flag` is present,

30 in case the `sps_mts_intra_enabled_flag` is equal to 1 it is specified that a Transform Unit, TU, Multiple Transform Selection, MTS flag, denote `tu_mts_flag`, is present in the residual coding syntax for intra coding units;

in case the `sps_mts_intra_enabled_flag` is equal to 0 it is specified that a `tu_mts_flag` is not present in the residual coding syntax for intra coding units;

wherein in case the `sps_mts_intra_enabled_flag` is not present, the `sps_mts_intra_enabled_flag` is inferred to be 0.

The present disclosure further provides an encoder comprising processing circuitry for carrying out the method according to the method according to any preceding implementation of the previous aspects or the previous aspect as such.

5

The present disclosure further provides a decoder comprising processing circuitry for carrying out the method according to any preceding implementation of the previous aspects or the previous aspect as such.

10 The present disclosure further provides a decoder comprising:

an obtaining unit, configured to obtain a residual signal resulting from inter- or intra-picture prediction;

an inferring unit, configured to infer use of a Discrete Cosine Transform type 2, DCT2, transform core for a sequence of the residual signal; and

15 a processing unit, configured to process the transformation of the block using the inferred transform core.

In a possible implementation form of the decoder according to the previous aspect as such, wherein the inferring unit is configured to infer use of DCT2 from a sequence level DCT2  
 20 enabled flag in the Sequence Parameter Set, SPS.

In a possible implementation form of the decoder according to the previous aspect as such, wherein the sequence level DCT2 enabled flag is denoted `sps_dct2_enabled_flag`.

25 In a possible implementation form of the decoder according to any preceding implementation of the previous two aspects or the previous aspect as such, wherein the sequence level DCT2 enabled flag is comprised in a SPS level syntax as follows:

	<b>Descriptor</b>
<code>seq_parameter_set_rbsp( ) {</code>	
<code>...</code>	<code>ue(v)</code>
<code>  sps_dct2_enabled_flag</code>	
<code>  if (! sps_dct2_enabled_flag) {</code>	
<code>    sps_mts_intra_enabled_flag</code>	<code>u(1)</code>
<code>    sps_mts_inter_enabled_flag</code>	<code>u(1)</code>
<code>  }</code>	
<code>...</code>	<code>u(1)</code>

}	
---	--

wherein `sps_dct2_enabled_flag` represents the sequence level DCT2 enabled flag.

In a possible implementation form of the decoder according to the previous aspect as such,  
5 wherein the `sps_mts_intra_enabled_flag` equal to 1 specifies that `tu_mts_flag` may be present in the residual coding syntax for intra coding units; `sps_mts_intra_enabled_flag` equal to 0 specifies that `tu_mts_flag` is not present in the residual coding syntax for intra coding units; and when the `sps_mts_intra_enabled_flag` is not present, the `sps_mts_intra_enabled_flag` is inferred to be 0.

10

In a possible implementation form of the decoder according to any preceding implementation of the previous two aspects or the previous aspect as such, wherein the `sps_mts_inter_enabled_flag` specifies that `tu_mts_flag` may be present in the residual coding syntax for inter coding units; `sps_mts_inter_enabled_flag` equal to 0 specifies that  
15 `tu_mts_flag` is not present in the residual coding syntax for inter coding units; and when the `sps_mts_intra_enabled_flag` is not present, the `sps_mts_intra_enabled_flag` is inferred to be 0.

In a possible implementation form of the decoder according to any preceding implementation of the previous five aspects or the previous aspect as such,  
20 wherein the sequence level DCT2 enabled flag being equal to 1 specifies that DCT2 transform core is used for transformation.

In a possible implementation form of the decoder according to any preceding implementation of the previous six aspects or the previous aspect as such,  
25 wherein the sequence level DCT2 enabled flag being equal to 1 specifies that DCT2 transform core is used for transformation, only.

In a possible implementation form of the decoder according to any preceding implementation of the previous seven aspects or the previous aspect as such, wherein the sequence level  
30 DCT2 enabled flag being equal to 1 specifies that DCT2 is used for both horizontal as well as vertical direction transformation.

In a possible implementation form of the decoder according to any preceding implementation

of the previous eight aspects or the previous aspect as such, wherein the sequence level DCT2 enabled flag being equal to 1 specifies that DCT2 is used in sub block transformation.

5 In a possible implementation form of the decoder according to the previous aspect as such, wherein in case one side of a residual Transform Unit,  $t_u$  is greater than 32, a corresponding transform is set as DCT2.

10 In a possible implementation form of the decoder according to any preceding implementation of the previous ten aspects or the previous aspect as such, wherein in case the sequence level DCT2 enabled flag is equal to 1 specifies that the DCT2 transform core is used for transformation, only, both the sub block transform as well as Multiple Transform Selection, MTS, transform are inferred as off.

15 In a possible implementation form of the decoder according to any preceding implementation of the previous eleven aspects or the previous aspect as such, wherein the sequence level DCT2 enabled flag being equal to 0 specifies that other transform cores than DCT2 are used for the transformation.

20 In a possible implementation form of the decoder according to the previous aspect as such, wherein the inferring unit is configured to infer using a Discrete Sine Transform type 7, DST7 and/or a Discrete Cosine Transform type 8, DCT8, for transformation.

25 In a possible implementation form of the decoder according to any preceding implementation of the previous two aspects or the previous aspect as such, wherein the sequence level DCT2 enabled flag being equal to 0 specifies that it is inferred using DST7/DCT8 for transformation, only.

30 In a possible implementation form of the decoder according to any preceding implementation of the previous three aspects or the previous aspect as such, wherein in case the sequence level DCT2 enabled flag being equal to 0, it is determined whether Multiple Transform Selection for Sequence Parameter Set is enabled via a flag.

In a possible implementation form of the decoder according to any preceding implementation

of the previous aspect as such,

wherein in case the `sps_mts_intra_enabled_flag` is present,

in case the `sps_mts_intra_enabled_flag` is equal to 1 it is specified that a Transform Unit, TU, Multiple Transform Selection, MTS flag, denote `tu_mts_flag`, is present in the residual coding syntax for intra coding units;

in case the `sps_mts_intra_enabled_flag` is equal to 0 it is specified that a `tu_mts_flag` is not present in the residual coding syntax for intra coding units;

wherein in case the `sps_mts_intra_enabled_flag` is not present, the `sps_mts_intra_enabled_flag` is inferred to be 0.

The present disclosure further provides an encoder comprising:

an obtaining unit, configured to obtain a residual signal resulting from inter- or intra-picture prediction;

an inferring unit, configured to infer use of a Discrete Cosine Transform type 2, DCT2, transform core for a sequence of the residual signal; and

a processing unit, configured to process the transformation of the block using the inferred transform core.

In a possible implementation form of the encoder according to any preceding implementation of the previous aspect as such, wherein the inferring unit is configured to infer use of DCT2 from a sequence level DCT2 enabled flag in the Sequence Parameter Set, SPS.

In a possible implementation form of the encoder according to any preceding implementation of the previous aspect as such, wherein the sequence level DCT2 enabled flag is denoted `sps_dct2_enabled_flag`.

In a possible implementation form of the encoder according to any preceding implementation of the previous two aspects or the previous aspect as such, wherein the sequence level DCT2 enabled flag is comprised in a SPS level syntax as follows:

	<b>Descriptor</b>
<code>seq_parameter_set_rbsp() {</code>	
...	<code>ue(v)</code>
<code>sps_dct2_enabled_flag</code>	
<code>if (!sps_dct2_enabled_flag) {</code>	
<code>sps_mts_intra_enabled_flag</code>	<code>u(1)</code>
<code>sps_mts_inter_enabled_flag</code>	<code>u(1)</code>

}	
...	u(1)
}	

wherein `sps_dct2_enabled_flag` represents the sequence level DCT2 enabled flag.

In a possible implementation form of the encoder according to the previous aspect as such,  
 5 wherein the `sps_mts_intra_enabled_flag` equal to 1 specifies that `tu_mts_flag` may be present in the residual coding syntax for intra coding units; `sps_mts_intra_enabled_flag` equal to 0 specifies that `tu_mts_flag` is not present in the residual coding syntax for intra coding units; and when the `sps_mts_intra_enabled_flag` is not present, the `sps_mts_intra_enabled_flag` is inferred to be 0.

10 In a possible implementation form of the encoder according to any preceding implementation of the previous two aspects or the previous aspect as such, wherein the `sps_mts_inter_enabled_flag` specifies that `tu_mts_flag` may be present in the residual coding syntax for inter coding units; `sps_mts_inter_enabled_flag` equal to 0 specifies that  
 15 `tu_mts_flag` is not present in the residual coding syntax for inter coding units; and when the `sps_mts_intra_enabled_flag` is not present, the `sps_mts_intra_enabled_flag` is inferred to be 0.

In a possible implementation form of the encoder according to any preceding implementation of the previous five aspects or the previous aspect as such,  
 20 wherein the sequence level DCT2 enabled flag being equal to 1 specifies that DCT2 transform core is used for transformation.

In a possible implementation form of the encoder according to any preceding implementation of the previous six aspects or the previous aspect as such,  
 25 wherein the sequence level DCT2 enabled flag being equal to 1 specifies that DCT2 transform core is used for transformation, only.

In a possible implementation form of the encoder according to any preceding implementation of the previous seven aspects or the previous aspect as such, wherein the sequence level  
 30 DCT2 enabled flag being equal to 1 specifies that DCT2 is used for both horizontal as well as vertical direction transformation.

In a possible implementation form of the encoder according to any preceding implementation of the previous eight aspects or the previous aspect as such, wherein the sequence level DCT2 enabled flag being equal to 1 specifies that DCT2 is used in sub block transformation.

5

In a possible implementation form of the encoder according to the previous aspect as such, wherein in case one side of a residual Transform Unit,  $t_u$  is greater than 32, a corresponding transform is set as DCT2.

10 In a possible implementation form of the encoder according to any preceding implementation of the previous ten aspects or the previous aspect as such, wherein in case the sequence level DCT2 enabled flag is equal to 1 specifies that the DCT2 transform core is used for transformation, only, both the sub block transform as well as Multiple Transform Selection, MTS, transform are inferred as off.

15

In a possible implementation form of the encoder according to any preceding implementation of the previous eleven aspects or the previous aspect as such,  
wherein the sequence level DCT2 enabled flag being equal to 0 specifies that other transform cores than DCT2 are used for the transformation.

20

In a possible implementation form of the encoder according to any preceding implementation of the previous aspect as such,  
wherein the inferring unit is configured to infer using a Discrete Sine Transform type 7, DST7 and/or a Discrete Cosine Transform type 8, DCT8, for transformation.

25

In a possible implementation form of the encoder according to any preceding implementation of the previous two aspects or the previous aspect as such, wherein the sequence level DCT2 enabled flag being equal to 0  
specifies that it is inferred using DST7/DCT8 for transformation, only.

30

In a possible implementation form of the encoder according to any preceding implementation of the previous three aspects or the previous aspect as such,  
wherein in case the sequence level DCT2 enabled flag being equal to 0, it is determined whether Multiple Transform Selection for Sequence Parameter Set is enabled via

a flag.

In a possible implementation form of the encoder according to any preceding implementation of the previous aspect as such,

- 5        wherein in case the `sps_mts_intra_enabled_flag` is present,  
          in case the `sps_mts_intra_enabled_flag` is equal to 1 it is specified that a Transform Unit, TU, Multiple Transform Selection, MTS flag, denote `tu_mts_flag`, is present in the residual coding syntax for intra coding units;  
          in case the `sps_mts_intra_enabled_flag` is equal to 0 it is specified that a  
10        `tu_mts_flag` is not present in the residual coding syntax for intra coding units;  
          wherein in case the `sps_mts_intra_enabled_flag` is not present, the  
`sps_mts_intra_enabled_flag` is inferred to be 0.

The present disclosure further provides a computer program product comprising a program  
15        code for performing the method according to any one any preceding implementation of the previous aspects or the previous aspect as such.

The present disclosure further provides a decoder, comprising:

- one or more processors; and  
20        a non-transitory computer-readable storage medium coupled to the processors and storing programming for execution by the processors, wherein the programming, when executed by the processors, configures the decoder to carry out the method according to any preceding implementation of the previous aspects or the previous aspect as such.

25        The present disclosure further provides an encoder, comprising:

- one or more processors; and  
          a non-transitory computer-readable storage medium coupled to the processors and storing programming for execution by the processors, wherein the programming, when  
30        according to any preceding implementation of the previous aspects or the previous aspect as such.

The present disclosure further provides a computer-readable non-transitory medium storing a program, including instructions which when executed on a processor cause the processor to

perform the method according to any preceding implementation of the previous aspects or the previous aspect as such.

5

## BRIEF DESCRIPTION OF THE DRAWINGS

In the following embodiments of the disclosure are described in more detail with reference to the attached figures and drawings, in which:

- 10 FIG. 1A is a block diagram showing an example of a video coding system configured to implement embodiments of the disclosure;
- FIG. 1B is a block diagram showing another example of a video coding system configured to implement embodiments of the disclosure;
- FIG. 2 is a block diagram showing an example of a video encoder configured to  
15 implement embodiments of the disclosure;
- FIG. 3 is a block diagram showing an example structure of a video decoder configured to implement embodiments of the disclosure;
- FIG. 4 is a block diagram illustrating an example of an encoding apparatus or a decoding apparatus;
- 20 FIG. 5 is a block diagram illustrating another example of an encoding apparatus or a decoding apparatus;
- FIG. 6 is a block diagram illustrating an example of the horizontal and vertical transforms for each SBT position.
- FIG. 7 is a block diagram illustrating another example of the horizontal and vertical  
25 transforms for each SBT position.
- FIG. 8 : illustrates a method of video coding a block of a picture according to the present disclosure.
- FIG. 9 illustrates an encoder.
- FIG. 10 illustrates a decoder.

30

In the following identical reference signs refer to identical or at least functionally equivalent features if not explicitly specified otherwise.

## DETAILED DESCRIPTION OF THE EMBODIMENTS

In the following description, reference is made to the accompanying figures, which form part of the disclosure, and which show, by way of illustration, specific aspects of embodiments of the disclosure or specific aspects in which embodiments of the present disclosure may be used. It is understood that embodiments of the disclosure may be used in other aspects and comprise structural or logical changes not depicted in the figures. The following detailed description, therefore, is not to be taken in a limiting sense, and the scope of the present disclosure is defined by the appended claims.

10

For instance, it is understood that a disclosure in connection with a described method may also hold true for a corresponding device or system configured to perform the method and vice versa. For example, if one or a plurality of specific method steps are described, a corresponding device may include one or a plurality of units, e.g. functional units, to perform the described one or plurality of method steps (e.g. one unit performing the one or plurality of steps, or a plurality of units each performing one or more of the plurality of steps), even if such one or more units are not explicitly described or illustrated in the figures. On the other hand, for example, if a specific apparatus is described based on one or a plurality of units, e.g. functional units, a corresponding method may include one step to perform the functionality of the one or plurality of units (e.g. one step performing the functionality of the one or plurality of units, or a plurality of steps each performing the functionality of one or more of the plurality of units), even if such one or plurality of steps are not explicitly described or illustrated in the figures. Further, it is understood that the features of the various exemplary embodiments and/or aspects described herein may be combined with each other, unless specifically noted otherwise.

15

20

25

Video coding typically refers to the processing of a sequence of pictures, which form the video or video sequence. Instead of the term “picture” the term “frame” or “image” may be used as synonyms in the field of video coding. Video coding (or coding in general) comprises two parts video encoding and video decoding. Video encoding is performed at the source side, typically comprising processing (e.g. by compression) the original video pictures to reduce the amount of data required for representing the video pictures (for more efficient storage and/or transmission). Video decoding is performed at the destination side and typically comprises the inverse processing compared to the encoder to reconstruct the video pictures.

30

Embodiments referring to “coding” of video pictures (or pictures in general) shall be understood to relate to “encoding” or “decoding” of video pictures or respective video sequences. The combination of the encoding part and the decoding part is also referred to as CODEC (Coding and Decoding).

5

In case of lossless video coding, the original video pictures can be reconstructed, i.e. the reconstructed video pictures have the same quality as the original video pictures (assuming no transmission loss or other data loss during storage or transmission). In case of lossy video coding, further compression, e.g. by quantization, is performed, to reduce the amount of data representing the video pictures, which cannot be completely reconstructed at the decoder, i.e. the quality of the reconstructed video pictures is lower or worse compared to the quality of the original video pictures.

Several video coding standards belong to the group of “lossy hybrid video codecs” (i.e. combine spatial and temporal prediction in the sample domain and 2D transform coding for applying quantization in the transform domain). Each picture of a video sequence is typically partitioned into a set of non-overlapping blocks and the coding is typically performed on a block level. In other words, at the encoder the video is typically processed, i.e. encoded, on a block (video block) level, e.g. by using spatial (intra picture) prediction and/or temporal (inter picture) prediction to generate a prediction block, subtracting the prediction block from the current block (block currently processed/to be processed) to obtain a residual block, transforming the residual block and quantizing the residual block in the transform domain to reduce the amount of data to be transmitted (compression), whereas at the decoder the inverse processing compared to the encoder is applied to the encoded or compressed block to reconstruct the current block for representation. Furthermore, the encoder duplicates the decoder processing loop such that both will generate identical predictions (e.g. intra- and inter predictions) and/or re-constructions for processing, i.e. coding, the subsequent blocks.

In the following embodiments of a video coding system 10, a video encoder 20 and a video decoder 30 are described based on Figs. 1 to 3.

Fig. 1A is a schematic block diagram illustrating an example coding system 10, e.g. a video coding system 10 (or short coding system 10) that may utilize techniques of this present application. Video encoder 20 (or short encoder 20) and video decoder 30 (or short decoder

30) of video coding system 10 represent examples of devices that may be configured to perform techniques in accordance with various examples described in the present application.

As shown in FIG. 1A, the coding system 10 comprises a source device 12 configured to provide encoded picture data 21 e.g. to a destination device 14 for decoding the encoded picture data 13.

The source device 12 comprises an encoder 20, and may additionally, i.e. optionally, comprise a picture source 16, a pre-processor (or pre-processing unit) 18, e.g. a picture pre-processor 18, and a communication interface or communication unit 22.

The picture source 16 may comprise or be any kind of picture capturing device, for example a camera for capturing a real-world picture, and/or any kind of a picture generating device, for example a computer-graphics processor for generating a computer animated picture, or any kind of other device for obtaining and/or providing a real-world picture, a computer generated picture (e.g. a screen content, a virtual reality (VR) picture) and/or any combination thereof (e.g. an augmented reality (AR) picture). The picture source may be any kind of memory or storage storing any of the aforementioned pictures.

In distinction to the pre-processor 18 and the processing performed by the pre-processing unit 18, the picture or picture data 17 may also be referred to as raw picture or raw picture data 17.

Pre-processor 18 is configured to receive the (raw) picture data 17 and to perform pre-processing on the picture data 17 to obtain a pre-processed picture 19 or pre-processed picture data 19. Pre-processing performed by the pre-processor 18 may, e.g., comprise trimming, color format conversion (e.g. from RGB to YCbCr), color correction, or de-noising. It can be understood that the pre-processing unit 18 may be optional component.

The video encoder 20 is configured to receive the pre-processed picture data 19 and provide encoded picture data 21 (further details will be described below, e.g., based on Fig. 2).

Communication interface 22 of the source device 12 may be configured to receive the encoded picture data 21 and to transmit the encoded picture data 21 (or any further processed

version thereof) over communication channel 13 to another device, e.g. the destination device 14 or any other device, for storage or direct reconstruction.

5 The destination device 14 comprises a decoder 30 (e.g. a video decoder 30), and may additionally, i.e. optionally, comprise a communication interface or communication unit 28, a post-processor 32 (or post-processing unit 32) and a display device 34.

10 The communication interface 28 of the destination device 14 is configured receive the encoded picture data 21 (or any further processed version thereof), e.g. directly from the source device 12 or from any other source, e.g. a storage device, e.g. an encoded picture data storage device, and provide the encoded picture data 21 to the decoder 30.

15 The communication interface 22 and the communication interface 28 may be configured to transmit or receive the encoded picture data 21 or encoded data 13 via a direct communication link between the source device 12 and the destination device 14, e.g. a direct wired or wireless connection, or via any kind of network, e.g. a wired or wireless network or any combination thereof, or any kind of private and public network, or any kind of combination thereof.

20 The communication interface 22 may be, e.g., configured to package the encoded picture data 21 into an appropriate format, e.g. packets, and/or process the encoded picture data using any kind of transmission encoding or processing for transmission over a communication link or communication network.

25 The communication interface 28, forming the counterpart of the communication interface 22, may be, e.g., configured to receive the transmitted data and process the transmission data using any kind of corresponding transmission decoding or processing and/or de-packaging to obtain the encoded picture data 21.

30 Both, communication interface 22 and communication interface 28 may be configured as unidirectional communication interfaces as indicated by the arrow for the communication channel 13 in Fig. 1A pointing from the source device 12 to the destination device 14, or bi-directional communication interfaces, and may be configured, e.g. to send and receive messages, e.g. to set up a connection, to acknowledge and exchange any other information

related to the communication link and/or data transmission, e.g. encoded picture data transmission.

5 The decoder 30 is configured to receive the encoded picture data 21 and provide decoded picture data 31 or a decoded picture 31 (further details will be described below, e.g., based on Fig. 3 or Fig. 5). The post-processor 32 of destination device 14 is configured to post-process the decoded picture data 31 (also called reconstructed picture data), e.g. the decoded picture 31, to obtain post-processed picture data 33, e.g. a post-processed picture 33. The post-processing performed by the post-processing unit 32 may comprise, e.g. color format  
10 conversion (e.g. from YCbCr to RGB), color correction, trimming, or re-sampling, or any other processing, e.g. for preparing the decoded picture data 31 for display, e.g. by display device 34.

The display device 34 of the destination device 14 is configured to receive the post-processed  
15 picture data 33 for displaying the picture, e.g. to a user or viewer. The display device 34 may be or comprise any kind of display for representing the reconstructed picture, e.g. an integrated or external display or monitor. The displays may, e.g. comprise liquid crystal displays (LCD), organic light emitting diodes (OLED) displays, plasma displays, projectors , micro LED displays, liquid crystal on silicon (LCoS), digital light processor (DLP) or any  
20 kind of other display.

Although Fig. 1A depicts the source device 12 and the destination device 14 as separate devices, embodiments of devices may also comprise both or both functionalities, the source device 12 or corresponding functionality and the destination device 14 or corresponding  
25 functionality. In such embodiments the source device 12 or corresponding functionality and the destination device 14 or corresponding functionality may be implemented using the same hardware and/or software or by separate hardware and/or software or any combination thereof.

30 As will be apparent for the skilled person based on the description, the existence and (exact) split of functionalities of the different units or functionalities within the source device 12 and/or destination device 14 as shown in Fig. 1A may vary depending on the actual device and application.

The encoder **20** (e.g. a video encoder 20) or the decoder **30** (e.g. a video decoder 30) or both encoder 20 and decoder 30 may be implemented via processing circuitry as shown in Fig. 1B, such as one or more microprocessors, digital signal processors (DSPs), application-specific integrated circuits (ASICs), field-programmable gate arrays (FPGAs), discrete logic,  
5 hardware, video coding dedicated or any combinations thereof. The encoder 20 may be implemented via processing circuitry 46 to embody the various modules as discussed with respect to encoder 20 of FIG. 2 and/or any other encoder system or subsystem described herein. The decoder 30 may be implemented via processing circuitry 46 to embody the various modules as discussed with respect to decoder 30 of FIG. 3 and/or any other decoder  
10 system or subsystem described herein. The processing circuitry may be configured to perform the various operations as discussed later. As shown in fig. 5, if the techniques are implemented partially in software, a device may store instructions for the software in a suitable, non-transitory computer-readable storage medium and may execute the instructions in hardware using one or more processors to perform the techniques of this disclosure. Either  
15 of video encoder **20** and video decoder **30** may be integrated as part of a combined encoder/decoder (CODEC) in a single device, for example, as shown in Fig. 1B.

Source device 12 and destination device 14 may comprise any of a wide range of devices, including any kind of handheld or stationary devices, e.g. notebook or laptop computers,  
20 mobile phones, smart phones, tablets or tablet computers, cameras, desktop computers, set-top boxes, televisions, display devices, digital media players, video gaming consoles, video streaming devices (such as content services servers or content delivery servers), broadcast receiver device, broadcast transmitter device, or the like and may use no or any kind of operating system. In some cases, the source device 12 and the destination device 14  
25 may be equipped for wireless communication. Thus, the source device 12 and the destination device 14 may be wireless communication devices.

In some cases, video coding system **10** illustrated in Fig. 1A is merely an example and the techniques of the present application may apply to video coding settings (e.g., video encoding  
30 or video decoding) that do not necessarily include any data communication between the encoding and decoding devices. In other examples, data is retrieved from a local memory, streamed over a network, or the like. A video encoding device may encode and store data to memory, and/or a video decoding device may retrieve and decode data from memory. In some examples, the encoding and decoding is performed by devices that do not communicate

with one another, but simply encode data to memory and/or retrieve and decode data from memory.

For convenience of description, embodiments of the disclosure are described herein, for example, by reference to High-Efficiency Video Coding (HEVC) or to the reference software of Versatile Video coding (VVC), the next generation video coding standard developed by the Joint Collaboration Team on Video Coding (JCT-VC) of ITU-T Video Coding Experts Group (VCEG) and ISO/IEC Motion Picture Experts Group (MPEG). One of ordinary skill in the art will understand that embodiments of the disclosure are not limited to HEVC or VVC.

10

#### Encoder and Encoding Method

Fig. 2 shows a schematic block diagram of an example video encoder 20 that is configured to implement the techniques of the present application. In the example of Fig. 2, the video encoder 20 comprises an input 201 (or input interface 201), a residual calculation unit 204, a transform processing unit 206, a quantization unit 208, an inverse quantization unit 210, and inverse transform processing unit 212, a reconstruction unit 214, a loop filter unit 220, a decoded picture buffer (DPB) 230, a mode selection unit 260, an entropy encoding unit 270 and an output 272 (or output interface 272). The mode selection unit 260 may include an inter prediction unit 244, an intra prediction unit 254 and a partitioning unit 262. Inter prediction unit 244 may include a motion estimation unit and a motion compensation unit (not shown). A video encoder 20 as shown in Fig. 2 may also be referred to as hybrid video encoder or a video encoder according to a hybrid video codec.

The residual calculation unit 204, the transform processing unit 206, the quantization unit 208, the mode selection unit 260 may be referred to as forming a forward signal path of the encoder 20, whereas the inverse quantization unit 210, the inverse transform processing unit 212, the reconstruction unit 214, the buffer 216, the loop filter 220, the decoded picture buffer (DPB) 230, the inter prediction unit 244 and the intra-prediction unit 254 may be referred to as forming a backward signal path of the video encoder 20, wherein the backward signal path of the video encoder 20 corresponds to the signal path of the decoder (see video decoder 30 in Fig. 3). The inverse quantization unit 210, the inverse transform processing unit 212, the reconstruction unit 214, the loop filter 220, the decoded picture buffer (DPB) 230, the inter prediction unit 244 and the intra-prediction unit 254 are also referred to forming the “built-in decoder” of video encoder 20.

### Pictures & Picture Partitioning (Pictures & Blocks)

The encoder 20 may be configured to receive, e.g. via input 201, a picture 17 (or picture data 17), e.g. picture of a sequence of pictures forming a video or video sequence. The received  
5 picture or picture data may also be a pre-processed picture 19 (or pre-processed picture data 19). For sake of simplicity the following description refers to the picture 17. The picture 17 may also be referred to as current picture or picture to be coded (in particular in video coding to distinguish the current picture from other pictures, e.g. previously encoded and/or decoded pictures of the same video sequence, i.e. the video sequence which also comprises the current  
10 picture).

A (digital) picture is or can be regarded as a two-dimensional array or matrix of samples with intensity values. A sample in the array may also be referred to as pixel (short form of picture element) or a pel. The number of samples in horizontal and vertical direction (or axis) of the  
15 array or picture define the size and/or resolution of the picture. For representation of color, typically three color components are employed, i.e. the picture may be represented or include three sample arrays. In RGB format or color space a picture comprises a corresponding red, green and blue sample array. However, in video coding each pixel is typically represented in a luminance and chrominance format or color space, e.g. YCbCr, which comprises a  
20 luminance component indicated by Y (sometimes also L is used instead) and two chrominance components indicated by Cb and Cr. The luminance (or short luma) component Y represents the brightness or grey level intensity (e.g. like in a grey-scale picture), while the two chrominance (or short chroma) components Cb and Cr represent the chromaticity or color information components. Accordingly, a picture in YCbCr format comprises a  
25 luminance sample array of luminance sample values (Y), and two chrominance sample arrays of chrominance values (Cb and Cr). Pictures in RGB format may be converted or transformed into YCbCr format and vice versa, the process is also known as color transformation or conversion. If a picture is monochrome, the picture may comprise only a luminance sample array. Accordingly, a picture may be, for example, an array of luma samples in monochrome  
30 format or an array of luma samples and two corresponding arrays of chroma samples in 4:2:0, 4:2:2, and 4:4:4 color format.

Embodiments of the video encoder 20 may comprise a picture partitioning unit (not depicted in Fig. 2) configured to partition the picture 17 into a plurality of (typically non-overlapping)

picture blocks 203. These blocks may also be referred to as root blocks, macro blocks (H.264/AVC) or coding tree blocks (CTB) or coding tree units (CTU) (H.265/HEVC and VVC). The picture partitioning unit may be configured to use the same block size for all pictures of a video sequence and the corresponding grid defining the block size, or to change the block size between pictures or subsets or groups of pictures, and partition each picture into the corresponding blocks.

In further embodiments, the video encoder may be configured to receive directly a block 203 of the picture 17, e.g. one, several or all blocks forming the picture 17. The picture block 203 may also be referred to as current picture block or picture block to be coded.

Like the picture 17, the picture block 203 again is or can be regarded as a two-dimensional array or matrix of samples with intensity values (sample values), although of smaller dimension than the picture 17. In other words, the block 203 may comprise, e.g., one sample array (e.g. a luma array in case of a monochrome picture 17, or a luma or chroma array in case of a color picture) or three sample arrays (e.g. a luma and two chroma arrays in case of a color picture 17) or any other number and/or kind of arrays depending on the color format applied. The number of samples in horizontal and vertical direction (or axis) of the block 203 define the size of block 203. Accordingly, a block may, for example, an  $M \times N$  ( $M$ -column by  $N$ -row) array of samples, or an  $M \times N$  array of transform coefficients.

Embodiments of the video encoder 20 as shown in Fig. 2 may be configured to encode the picture 17 block by block, e.g. the encoding and prediction is performed per block 203.

Embodiments of the video encoder 20 as shown in Fig. 2 may be further configured to partition and/or encode the picture by using slices (also referred to as video slices), wherein a picture may be partitioned into or encoded using one or more slices (typically non-overlapping), and each slice may comprise one or more blocks (e.g. CTUs).

Embodiments of the video encoder 20 as shown in Fig. 2 may be further configured to partition and/or encode the picture by using tile groups (also referred to as video tile groups) and/or tiles (also referred to as video tiles), wherein a picture may be partitioned into or encoded using one or more tile groups (typically non-overlapping), and each tile group may comprise, e.g. one or more blocks (e.g. CTUs) or one or more tiles, wherein each tile, e.g.

may be of rectangular shape and may comprise one or more blocks (e.g. CTUs), e.g. complete or fractional blocks.

#### Residual Calculation

5 The residual calculation unit 204 may be configured to calculate a residual block 205 (also referred to as residual 205) based on the picture block 203 and a prediction block 265 (further details about the prediction block 265 are provided later), e.g. by subtracting sample values of the prediction block 265 from sample values of the picture block 203, sample by sample (pixel by pixel) to obtain the residual block 205 in the sample domain.

10

#### Transform

The transform processing unit 206 may be configured to apply a transform, e.g. a discrete cosine transform (DCT) or discrete sine transform (DST), on the sample values of the residual block 205 to obtain transform coefficients 207 in a transform domain. The transform  
15 coefficients 207 may also be referred to as transform residual coefficients and represent the residual block 205 in the transform domain.

The transform processing unit 206 may be configured to apply integer approximations of DCT/DST, such as the transforms specified for H.265/HEVC. Compared to an orthogonal  
20 DCT transform, such integer approximations are typically scaled by a certain factor. In order to preserve the norm of the residual block, which is processed by forward and inverse transforms, additional scaling factors are applied as part of the transform process. The scaling factors are typically chosen based on certain constraints like scaling factors being a power of two for shift operations, bit depth of the transform coefficients, tradeoff between accuracy  
25 and implementation costs, etc. Specific scaling factors are, for example, specified for the inverse transform, e.g. by inverse transform processing unit 212 (and the corresponding inverse transform, e.g. by inverse transform processing unit 312 at video decoder 30) and corresponding scaling factors for the forward transform, e.g. by transform processing unit 206, at an encoder 20 may be specified accordingly.

30

Embodiments of the video encoder 20 (respectively transform processing unit 206) may be configured to output transform parameters, e.g. a type of transform or transforms, e.g. directly or encoded or compressed via the entropy encoding unit 270, so that, e.g., the video decoder 30 may receive and use the transform parameters for decoding.

## Quantization

The quantization unit 208 may be configured to quantize the transform coefficients 207 to obtain quantized coefficients 209, e.g. by applying scalar quantization or vector quantization.

5 The quantized coefficients 209 may also be referred to as quantized transform coefficients 209 or quantized residual coefficients 209.

The quantization process may reduce the bit depth associated with some or all of the transform coefficients 207. For example, an n-bit transform coefficient may be rounded down to an m-bit Transform coefficient during quantization, where n is greater than m. The degree of quantization may be modified by adjusting a quantization parameter (QP). For example for scalar quantization, different scaling may be applied to achieve finer or coarser quantization. Smaller quantization step sizes correspond to finer quantization, whereas larger quantization step sizes correspond to coarser quantization. The applicable quantization step size may be indicated by a quantization parameter (QP). The quantization parameter may for example be an index to a predefined set of applicable quantization step sizes. For example, small quantization parameters may correspond to fine quantization (small quantization step sizes) and large quantization parameters may correspond to coarse quantization (large quantization step sizes) or vice versa. The quantization may include division by a quantization step size and a corresponding and/or the inverse dequantization, e.g. by inverse quantization unit 210, may include multiplication by the quantization step size. Embodiments according to some standards, e.g. HEVC, may be configured to use a quantization parameter to determine the quantization step size. Generally, the quantization step size may be calculated based on a quantization parameter using a fixed-point approximation of an equation including division. Additional scaling factors may be introduced for quantization and dequantization to restore the norm of the residual block, which might get modified because of the scaling used in the fixed point approximation of the equation for quantization step size and quantization parameter. In one example implementation, the scaling of the inverse transform and dequantization might be combined. Alternatively, customized quantization tables may be used and signaled from an encoder to a decoder, e.g. in a bitstream. The quantization is a lossy operation, wherein the loss increases with increasing quantization step sizes.

Embodiments of the video encoder 20 (respectively quantization unit 208) may be configured to output quantization parameters (QP), e.g. directly or encoded via the entropy encoding unit

270, so that, e.g., the video decoder 30 may receive and apply the quantization parameters for decoding.

#### Inverse Quantization

5 The inverse quantization unit 210 is configured to apply the inverse quantization of the quantization unit 208 on the quantized coefficients to obtain dequantized coefficients 211, e.g. by applying the inverse of the quantization scheme applied by the quantization unit 208 based on or using the same quantization step size as the quantization unit 208. The dequantized coefficients 211 may also be referred to as dequantized residual coefficients 211 and  
10 correspond - although typically not identical to the transform coefficients due to the loss by quantization - to the transform coefficients 207.

#### Inverse Transform

The inverse transform processing unit 212 is configured to apply the inverse transform of the  
15 transform applied by the transform processing unit 206, e.g. an inverse discrete cosine transform (DCT) or inverse discrete sine transform (DST) or other inverse transforms, to obtain a reconstructed residual block 213 (or corresponding dequantized coefficients 213) in the sample domain. The reconstructed residual block 213 may also be referred to as  
transform block 213.

20

#### Reconstruction

The reconstruction unit 214 (e.g. adder or summer 214) is configured to add the transform  
block 213 (i.e. reconstructed residual block 213) to the prediction block 265 to obtain a  
reconstructed block 215 in the sample domain, e.g. by adding – sample by sample - the  
25 sample values of the reconstructed residual block 213 and the sample values of the prediction  
block 265.

#### Filtering

The loop filter unit 220 (or short “loop filter” 220), is configured to filter the reconstructed  
30 block 215 to obtain a filtered block 221, or in general, to filter reconstructed samples to  
obtain filtered samples. The loop filter unit is, e.g., configured to smooth pixel transitions, or  
otherwise improve the video quality. The loop filter unit 220 may comprise one or more loop  
filters such as a de-blocking filter, a sample-adaptive offset (SAO) filter or one or more other  
filters, e.g. a bilateral filter, an adaptive loop filter (ALF), a sharpening, a smoothing filters or

a collaborative filters, or any combination thereof. Although the loop filter unit 220 is shown in FIG. 2 as being an in loop filter, in other configurations, the loop filter unit 220 may be implemented as a post loop filter. The filtered block 221 may also be referred to as filtered reconstructed block 221.

5

Embodiments of the video encoder 20 (respectively loop filter unit 220) may be configured to output loop filter parameters (such as sample adaptive offset information), e.g. directly or encoded via the entropy encoding unit 270, so that, e.g., a decoder 30 may receive and apply the same loop filter parameters or respective loop filters for decoding.

10

#### Decoded Picture Buffer

The decoded picture buffer (DPB) 230 may be a memory that stores reference pictures, or in general reference picture data, for encoding video data by video encoder 20. The DPB 230 may be formed by any of a variety of memory devices, such as dynamic random access  
15 memory (DRAM), including synchronous DRAM (SDRAM), magnetoresistive RAM (MRAM), resistive RAM (RRAM), or other types of memory devices. The decoded picture buffer (DPB) 230 may be configured to store one or more filtered blocks 221. The decoded picture buffer 230 may be further configured to store other previously filtered blocks, e.g. previously reconstructed and filtered blocks 221, of the same current picture or of different  
20 pictures, e.g. previously reconstructed pictures, and may provide complete previously reconstructed, i.e. decoded, pictures (and corresponding reference blocks and samples) and/or a partially reconstructed current picture (and corresponding reference blocks and samples), for example for inter prediction. The decoded picture buffer (DPB) 230 may be also configured to store one or more unfiltered reconstructed blocks 215, or in general unfiltered  
25 reconstructed samples, e.g. if the reconstructed block 215 is not filtered by loop filter unit 220, or any other further processed version of the reconstructed blocks or samples.

#### Mode Selection (Partitioning & Prediction)

The mode selection unit 260 comprises partitioning unit 262, inter-prediction unit 244 and  
30 intra-prediction unit 254, and is configured to receive or obtain original picture data, e.g. an original block 203 (current block 203 of the current picture 17), and reconstructed picture data, e.g. filtered and/or unfiltered reconstructed samples or blocks of the same (current) picture and/or from one or a plurality of previously decoded pictures, e.g. from decoded picture buffer 230 or other buffers (e.g. line buffer, not shown).. The reconstructed picture

data is used as reference picture data for prediction, e.g. inter-prediction or intra-prediction, to obtain a prediction block 265 or predictor 265.

Mode selection unit 260 may be configured to determine or select a partitioning for a current  
5 block prediction mode (including no partitioning) and a prediction mode (e.g. an intra or inter prediction mode) and generate a corresponding prediction block 265, which is used for the calculation of the residual block 205 and for the reconstruction of the reconstructed block 215.

10 Embodiments of the mode selection unit 260 may be configured to select the partitioning and the prediction mode (e.g. from those supported by or available for mode selection unit 260), which provide the best match or in other words the minimum residual (minimum residual means better compression for transmission or storage), or a minimum signaling overhead (minimum signaling overhead means better compression for transmission or storage), or  
15 which considers or balances both. The mode selection unit 260 may be configured to determine the partitioning and prediction mode based on rate distortion optimization (RDO), i.e. select the prediction mode, which provides a minimum rate distortion. Terms like “best”, “minimum”, “optimum” etc. in this context do not necessarily refer to an overall “best”, “minimum”, “optimum”, etc. but may also refer to the fulfillment of a termination or  
20 selection criterion like a value exceeding or falling below a threshold or other constraints leading potentially to a “sub-optimum selection” but reducing complexity and processing time.

In other words, the partitioning unit 262 may be configured to partition the block 203 into  
25 smaller block partitions or sub-blocks (which form again blocks), e.g. iteratively using quad-tree-partitioning (QT), binary partitioning (BT) or triple-tree-partitioning (TT) or any combination thereof, and to perform, e.g., the prediction for each of the block partitions or sub-blocks, wherein the mode selection comprises the selection of the tree-structure of the partitioned block 203 and the prediction modes are applied to each of the block partitions or  
30 sub-blocks.

In the following the partitioning (e.g. by partitioning unit 260) and prediction processing (by inter-prediction unit 244 and intra-prediction unit 254) performed by an example video encoder 20 will be explained in more detail.

## Partitioning

The partitioning unit 262 may partition (or split) a current block 203 into smaller partitions, e.g. smaller blocks of square or rectangular size. These smaller blocks (which may also be referred to as sub-blocks) may be further partitioned into even smaller partitions. This is also referred to tree-partitioning or hierarchical tree-partitioning, wherein a root block, e.g. at root tree-level 0 (hierarchy-level 0, depth 0), may be recursively partitioned, e.g. partitioned into two or more blocks of a next lower tree-level, e.g. nodes at tree-level 1 (hierarchy-level 1, depth 1), wherein these blocks may be again partitioned into two or more blocks of a next lower level, e.g. tree-level 2 (hierarchy-level 2, depth 2), etc. until the partitioning is terminated, e.g. because a termination criterion is fulfilled, e.g. a maximum tree depth or minimum block size is reached. Blocks, which are not further partitioned, are also referred to as leaf-blocks or leaf nodes of the tree. A tree using partitioning into two partitions is referred to as binary-tree (BT), a tree using partitioning into three partitions is referred to as ternary-tree (TT), and a tree using partitioning into four partitions is referred to as quad-tree (QT).

As mentioned before, the term “block” as used herein may be a portion, in particular a square or rectangular portion, of a picture. With reference, for example, to HEVC and VVC, the block may be or correspond to a coding tree unit (CTU), a coding unit (CU), prediction unit (PU), and transform unit (TU) and/or to the corresponding blocks, e.g. a coding tree block (CTB), a coding block (CB), a transform block (TB) or prediction block (PB).

For example, a coding tree unit (CTU) may be or comprise a CTB of luma samples, two corresponding CTBs of chroma samples of a picture that has three sample arrays, or a CTB of samples of a monochrome picture or a picture that is coded using three separate color planes and syntax structures used to code the samples. Correspondingly, a coding tree block (CTB) may be an  $N \times N$  block of samples for some value of  $N$  such that the division of a component into CTBs is a partitioning. A coding unit (CU) may be or comprise a coding block of luma samples, two corresponding coding blocks of chroma samples of a picture that has three sample arrays, or a coding block of samples of a monochrome picture or a picture that is coded using three separate color planes and syntax structures used to code the samples. Correspondingly, a coding block (CB) may be an  $M \times N$  block of samples for some values of  $M$  and  $N$  such that the division of a CTB into coding blocks is a partitioning.

In embodiments, e.g., according to HEVC, a coding tree unit (CTU) may be split into CUs by using a quad-tree structure denoted as coding tree. The decision whether to code a picture area using inter-picture (temporal) or intra-picture (spatial) prediction is made at the CU level.

- 5 Each CU can be further split into one, two or four PUs according to the PU splitting type. Inside one PU, the same prediction process is applied and the relevant information is transmitted to the decoder on a PU basis. After obtaining the residual block by applying the prediction process based on the PU splitting type, a CU can be partitioned into transform units (TUs) according to another quadtree structure similar to the coding tree for the CU.

10

In embodiments, e.g., according to the latest video coding standard currently in development, which is referred to as Versatile Video Coding (VVC), a combined Quad-tree and binary tree (QTBT) partitioning is for example used to partition a coding block. In the QTBT block structure, a CU can have either a square or rectangular shape. For example, a coding tree unit (CTU) is first partitioned by a quadtree structure. The quadtree leaf nodes are further partitioned by a binary tree or ternary (or triple) tree structure. The partitioning tree leaf nodes are called coding units (CUs), and that segmentation is used for prediction and transform processing without any further partitioning. This means that the CU, PU and TU have the same block size in the QTBT coding block structure. In parallel, multiple partition, for example, triple tree partition may be used together with the QTBT block structure.

20

In one example, the mode selection unit 260 of video encoder 20 may be configured to perform any combination of the partitioning techniques described herein.

- 25 As described above, the video encoder 20 is configured to determine or select the best or an optimum prediction mode from a set of (e.g. pre-determined) prediction modes. The set of prediction modes may comprise, e.g., intra-prediction modes and/or inter-prediction modes.

#### Intra-Prediction

- 30 The set of intra-prediction modes may comprise 35 different intra-prediction modes, e.g. non-directional modes like DC (or mean) mode and planar mode, or directional modes, e.g. as defined in HEVC, or may comprise 67 different intra-prediction modes, e.g. non-directional modes like DC (or mean) mode and planar mode, or directional modes, e.g. as defined for VVC.

The intra-prediction unit 254 is configured to use reconstructed samples of neighboring blocks of the same current picture to generate an intra-prediction block 265 according to an intra-prediction mode of the set of intra-prediction modes.

5

The intra prediction unit 254 (or in general the mode selection unit 260) is further configured to output intra-prediction parameters (or in general information indicative of the selected intra prediction mode for the block) to the entropy encoding unit 270 in form of syntax elements 266 for inclusion into the encoded picture data 21, so that, e.g., the video decoder 30 may receive and use the prediction parameters for decoding.

10

### Inter-Prediction

The set of (or possible) inter-prediction modes depends on the available reference pictures (i.e. previous at least partially decoded pictures, e.g. stored in DBP 230) and other inter-prediction parameters, e.g. whether the whole reference picture or only a part, e.g. a search window area around the area of the current block, of the reference picture is used for searching for a best matching reference block, and/or e.g. whether pixel interpolation is applied, e.g. half/semi-pel and/or quarter-pel interpolation, or not.

15

Additional to the above prediction modes, skip mode and/or direct mode may be applied.

20

The inter prediction unit 244 may include a motion estimation (ME) unit and a motion compensation (MC) unit (both not shown in Fig.2). The motion estimation unit may be configured to receive or obtain the picture block 203 (current picture block 203 of the current picture 17) and a decoded picture 231, or at least one or a plurality of previously reconstructed blocks, e.g. reconstructed blocks of one or a plurality of other/different previously decoded pictures 231, for motion estimation. E.g. a video sequence may comprise the current picture and the previously decoded pictures 231, or in other words, the current picture and the previously decoded pictures 231 may be part of or form a sequence of pictures forming a video sequence.

25

30

The encoder 20 may, e.g., be configured to select a reference block from a plurality of reference blocks of the same or different pictures of the plurality of other pictures and provide a reference picture (or reference picture index) and/or an offset (spatial offset)

between the position (x, y coordinates) of the reference block and the position of the current block as inter prediction parameters to the motion estimation unit. This offset is also called motion vector (MV).

5 The motion compensation unit is configured to obtain, e.g. receive, an inter prediction parameter and to perform inter prediction based on or using the inter prediction parameter to obtain an inter prediction block 265. Motion compensation, performed by the motion compensation unit, may involve fetching or generating the prediction block based on the motion/block vector determined by motion estimation, possibly performing interpolations to  
10 sub-pixel precision. Interpolation filtering may generate additional pixel samples from known pixel samples, thus potentially increasing the number of candidate prediction blocks that may be used to code a picture block. Upon receiving the motion vector for the PU of the current picture block, the motion compensation unit may locate the prediction block to which the motion vector points in one of the reference picture lists.

15

The motion compensation unit may also generate syntax elements associated with the blocks and video slices for use by video decoder 30 in decoding the picture blocks of the video slice. In addition or as an alternative to slices and respective syntax elements, tile groups and/or tiles and respective syntax elements may be generated or used.

20

### Entropy Coding

The entropy encoding unit 270 is configured to apply, for example, an entropy encoding algorithm or scheme (e.g. a variable length coding (VLC) scheme, an context adaptive VLC scheme (CAVLC), an arithmetic coding scheme, a binarization, a context adaptive binary  
25 arithmetic coding (CABAC), syntax-based context-adaptive binary arithmetic coding (SBAC), probability interval partitioning entropy (PIPE) coding or another entropy encoding methodology or technique) or bypass (no compression) on the quantized coefficients 209, inter prediction parameters, intra prediction parameters, loop filter parameters and/or other syntax elements to obtain encoded picture data 21 which can be output via the output 272, e.g.  
30 in the form of an encoded bitstream 21, so that, e.g., the video decoder 30 may receive and use the parameters for decoding, . The encoded bitstream 21 may be transmitted to video decoder 30, or stored in a memory for later transmission or retrieval by video decoder 30.

Other structural variations of the video encoder 20 can be used to encode the video stream. For example, a non-transform based encoder 20 can quantize the residual signal directly without the transform processing unit 206 for certain blocks or frames. In another implementation, an encoder 20 can have the quantization unit 208 and the inverse  
5 quantization unit 210 combined into a single unit.

#### Decoder and Decoding Method

Fig. 3 shows an example of a video decoder 30 that is configured to implement the techniques of this present application. The video decoder 30 is configured to receive encoded  
10 picture data 21 (e.g. encoded bitstream 21), e.g. encoded by encoder 20, to obtain a decoded picture 331. The encoded picture data or bitstream comprises information for decoding the encoded picture data, e.g. data that represents picture blocks of an encoded video slice (and/or tile groups or tiles) and associated syntax elements.

15 In the example of Fig. 3, the decoder 30 comprises an entropy decoding unit 304, an inverse quantization unit 310, an inverse transform processing unit 312, a reconstruction unit 314 (e.g. a summer 314), a loop filter 320, a decoded picture buffer (DBP) 330, a mode application unit 360, an inter prediction unit 344 and an intra prediction unit 354. Inter prediction unit 344 may be or include a motion compensation unit. Video decoder 30 may, in some examples,  
20 perform a decoding pass generally reciprocal to the encoding pass described with respect to video encoder 100 from FIG. 2.

As explained with regard to the encoder 20, the inverse quantization unit 210, the inverse transform processing unit 212, the reconstruction unit 214 the loop filter 220, the decoded  
25 picture buffer (DPB) 230, the inter prediction unit 344 and the intra prediction unit 354 are also referred to as forming the “built-in decoder” of video encoder 20. Accordingly, the inverse quantization unit 310 may be identical in function to the inverse quantization unit 110, the inverse transform processing unit 312 may be identical in function to the inverse transform processing unit 212, the reconstruction unit 314 may be identical in function to  
30 reconstruction unit 214, the loop filter 320 may be identical in function to the loop filter 220, and the decoded picture buffer 330 may be identical in function to the decoded picture buffer 230. Therefore, the explanations provided for the respective units and functions of the video 20 encoder apply correspondingly to the respective units and functions of the video decoder 30.

### Entropy Decoding

The entropy decoding unit 304 is configured to parse the bitstream 21 (or in general encoded picture data 21) and perform, for example, entropy decoding to the encoded picture data 21 to obtain, e.g., quantized coefficients 309 and/or decoded coding parameters (not shown in Fig. 3), e.g. any or all of inter prediction parameters (e.g. reference picture index and motion vector), intra prediction parameter (e.g. intra prediction mode or index), transform parameters, quantization parameters, loop filter parameters, and/or other syntax elements. Entropy decoding unit 304 maybe configured to apply the decoding algorithms or schemes corresponding to the encoding schemes as described with regard to the entropy encoding unit 270 of the encoder 20. Entropy decoding unit 304 may be further configured to provide inter prediction parameters, intra prediction parameter and/or other syntax elements to the mode application unit 360 and other parameters to other units of the decoder 30. Video decoder 30 may receive the syntax elements at the video slice level and/or the video block level. In addition or as an alternative to slices and respective syntax elements, tile groups and/or tiles and respective syntax elements may be received and/or used.

### Inverse Quantization

The inverse quantization unit 310 may be configured to receive quantization parameters (QP) (or in general information related to the inverse quantization) and quantized coefficients from the encoded picture data 21 (e.g. by parsing and/or decoding, e.g. by entropy decoding unit 304) and to apply based on the quantization parameters an inverse quantization on the decoded quantized coefficients 309 to obtain dequantized coefficients 311, which may also be referred to as transform coefficients 311. The inverse quantization process may include use of a quantization parameter determined by video encoder 20 for each video block in the video slice (or tile or tile group) to determine a degree of quantization and, likewise, a degree of inverse quantization that should be applied.

### Inverse Transform

Inverse transform processing unit 312 may be configured to receive dequantized coefficients 311, also referred to as transform coefficients 311, and to apply a transform to the dequantized coefficients 311 in order to obtain reconstructed residual blocks 213 in the sample domain. The reconstructed residual blocks 213 may also be referred to as transform blocks 313. The transform may be an inverse transform, e.g., an inverse DCT, an inverse

DST, an inverse integer transform, or a conceptually similar inverse transform process. The inverse transform processing unit 312 may be further configured to receive transform parameters or corresponding information from the encoded picture data 21 (e.g. by parsing and/or decoding, e.g. by entropy decoding unit 304) to determine the transform to be applied to the dequantized coefficients 311.

#### Reconstruction

The reconstruction unit 314 (e.g. adder or summer 314) may be configured to add the reconstructed residual block 313, to the prediction block 365 to obtain a reconstructed block 315 in the sample domain, e.g. by adding the sample values of the reconstructed residual block 313 and the sample values of the prediction block 365.

#### Filtering

The loop filter unit 320 (either in the coding loop or after the coding loop) is configured to filter the reconstructed block 315 to obtain a filtered block 321, e.g. to smooth pixel transitions, or otherwise improve the video quality. The loop filter unit 320 may comprise one or more loop filters such as a de-blocking filter, a sample-adaptive offset (SAO) filter or one or more other filters, e.g. a bilateral filter, an adaptive loop filter (ALF), a sharpening, a smoothing filters or a collaborative filters, or any combination thereof. Although the loop filter unit 320 is shown in FIG. 3 as being an in loop filter, in other configurations, the loop filter unit 320 may be implemented as a post loop filter.

#### Decoded Picture Buffer

The decoded video blocks 321 of a picture are then stored in decoded picture buffer 330, which stores the decoded pictures 331 as reference pictures for subsequent motion compensation for other pictures and/or for output respectively display.

The decoder 30 is configured to output the decoded picture 311, e.g. via output 312, for presentation or viewing to a user.

#### Prediction

The inter prediction unit 344 may be identical to the inter prediction unit 244 (in particular to the motion compensation unit) and the intra prediction unit 354 may be identical to the inter prediction unit 254 in function, and performs split or partitioning decisions and prediction

based on the partitioning and/or prediction parameters or respective information received from the encoded picture data 21 (e.g. by parsing and/or decoding, e.g. by entropy decoding unit 304). Mode application unit 360 may be configured to perform the prediction (intra or inter prediction) per block based on reconstructed pictures, blocks or respective samples  
5 (filtered or unfiltered) to obtain the prediction block 365.

When the video slice is coded as an intra coded (I) slice, intra prediction unit 354 of mode application unit 360 is configured to generate prediction block 365 for a picture block of the current video slice based on a signaled intra prediction mode and data from previously  
10 decoded blocks of the current picture. When the video picture is coded as an inter coded (i.e., B, or P) slice, inter prediction unit 344 (e.g. motion compensation unit) of mode application unit 360 is configured to produce prediction blocks 365 for a video block of the current video slice based on the motion vectors and other syntax elements received from entropy decoding unit 304. For inter prediction, the prediction blocks may be produced from one of the  
15 reference pictures within one of the reference picture lists. Video decoder 30 may construct the reference frame lists, List 0 and List 1, using default construction techniques based on reference pictures stored in DPB 330. The same or similar may be applied for or by embodiments using tile groups (e.g. video tile groups) and/or tiles (e.g. video tiles) in addition or alternatively to slices (e.g. video slices), e.g. a video may be coded using I, P or B  
20 tile groups and /or tiles.

Mode application unit 360 is configured to determine the prediction information for a video block of the current video slice by parsing the motion vectors or related information and other syntax elements, and uses the prediction information to produce the prediction blocks for the  
25 current video block being decoded. For example, the mode application unit 360 uses some of the received syntax elements to determine a prediction mode (e.g., intra or inter prediction) used to code the video blocks of the video slice, an inter prediction slice type (e.g., B slice, P slice, or GPB slice), construction information for one or more of the reference picture lists for the slice, motion vectors for each inter encoded video block of the slice, inter prediction  
30 status for each inter coded video block of the slice, and other information to decode the video blocks in the current video slice. The same or similar may be applied for or by embodiments using tile groups (e.g. video tile groups) and/or tiles (e.g. video tiles) in addition or alternatively to slices (e.g. video slices), e.g. a video may be coded using I, P or B tile groups and/or tiles.

Embodiments of the video decoder 30 as shown in Fig. 3 may be configured to partition and/or decode the picture by using slices (also referred to as video slices), wherein a picture may be partitioned into or decoded using one or more slices (typically non-overlapping), and  
5 each slice may comprise one or more blocks (e.g. CTUs).

Embodiments of the video decoder 30 as shown in Fig. 3 may be configured to partition and/or decode the picture by using tile groups (also referred to as video tile groups) and/or tiles (also referred to as video tiles), wherein a picture may be partitioned into or decoded  
10 using one or more tile groups (typically non-overlapping), and each tile group may comprise, e.g. one or more blocks (e.g. CTUs) or one or more tiles, wherein each tile, e.g. may be of rectangular shape and may comprise one or more blocks (e.g. CTUs), e.g. complete or fractional blocks.

15 Other variations of the video decoder 30 can be used to decode the encoded picture data 21. For example, the decoder 30 can produce the output video stream without the loop filtering unit 320. For example, a non-transform based decoder 30 can inverse-quantize the residual signal directly without the inverse-transform processing unit 312 for certain blocks or frames. In another implementation, the video decoder 30 can have the inverse-quantization unit 310  
20 and the inverse-transform processing unit 312 combined into a single unit.

It should be understood that, in the encoder 20 and the decoder 30, a processing result of a current step may be further processed and then output to the next step. For example, after interpolation filtering, motion vector derivation or loop filtering, a further operation, such as  
25 Clip or shift, may be performed on the processing result of the interpolation filtering, motion vector derivation or loop filtering.

It should be noted that further operations may be applied to the derived motion vectors of current block (including but not limit to control point motion vectors of affine mode, sub-block motion vectors in affine, planar, ATMVP modes, temporal motion vectors, and so  
30 on). For example, the value of motion vector is constrained to a predefined range according to its representing bit. If the representing bit of motion vector is bitDepth, then the range is  $-2^{(\text{bitDepth}-1)} \sim 2^{(\text{bitDepth}-1)-1}$ , where “^” means exponentiation. For example, if bitDepth is set equal to 16, the range is  $-32768 \sim 32767$ ; if bitDepth is set equal to 18, the

range is -131072~131071. For example, the value of the derived motion vector (e.g. the MVs of four 4x4 sub-blocks within one 8x8 block) is constrained such that the max difference between integer parts of the four 4x4 sub-block MVs is no more than N pixels, such as no more than 1 pixel. Here provides two methods for constraining the motion vector according to the bitDepth.

Method 1: remove the overflow MSB (most significant bit) by flowing operations

$$ux = (mvx + 2^{\text{bitDepth}}) \% 2^{\text{bitDepth}} \quad (1)$$

$$mvx = (ux \geq 2^{\text{bitDepth}-1}) ? (ux - 2^{\text{bitDepth}}) : ux \quad (2)$$

$$uy = (mvy + 2^{\text{bitDepth}}) \% 2^{\text{bitDepth}} \quad (3)$$

$$mvy = (uy \geq 2^{\text{bitDepth}-1}) ? (uy - 2^{\text{bitDepth}}) : uy \quad (4)$$

where mvx is a horizontal component of a motion vector of an image block or a sub-block, mvy is a vertical component of a motion vector of an image block or a sub-block, and ux and uy indicates an intermediate value;

For example, if the value of mvx is -32769, after applying formula (1) and (2), the resulting value is 32767. In computer system, decimal numbers are stored as two's complement. The two's complement of -32769 is 1,0111,1111,1111,1111 (17 bits), then the MSB is discarded, so the resulting two's complement is 0111,1111,1111,1111 (decimal number is 32767), which is same as the output by applying formula (1) and (2).

$$ux = (mvp_x + mvd_x + 2^{\text{bitDepth}}) \% 2^{\text{bitDepth}} \quad (5)$$

$$mvx = (ux \geq 2^{\text{bitDepth}-1}) ? (ux - 2^{\text{bitDepth}}) : ux \quad (6)$$

$$uy = (mvp_y + mvd_y + 2^{\text{bitDepth}}) \% 2^{\text{bitDepth}} \quad (7)$$

$$mvy = (uy \geq 2^{\text{bitDepth}-1}) ? (uy - 2^{\text{bitDepth}}) : uy \quad (8)$$

The operations may be applied during the sum of mvp and mvd, as shown in formula (5) to (8).

Method 2: remove the overflow MSB by clipping the value

$$vx = \text{Clip3}(-2^{\text{bitDepth}-1}, 2^{\text{bitDepth}-1} - 1, vx)$$

$$vy = \text{Clip3}(-2^{\text{bitDepth}-1}, 2^{\text{bitDepth}-1} - 1, vy)$$

where  $v_x$  is a horizontal component of a motion vector of an image block or a sub-block,  $v_y$  is a vertical component of a motion vector of an image block or a sub-block;  $x$ ,  $y$  and  $z$  respectively correspond to three input value of the MV clipping process, and the definition of function Clip3 is as follow:

$$\text{Clip3}(x, y, z) = \begin{cases} x & ; & z < x \\ y & ; & z > y \\ z & ; & \text{otherwise} \end{cases}$$

FIG. 4 is a schematic diagram of a video coding device 400 according to an embodiment of the disclosure. The video coding device 400 is suitable for implementing the disclosed embodiments as described herein. In an embodiment, the video coding device 400 may be a decoder such as video decoder 30 of FIG. 1A or an encoder such as video encoder 20 of FIG. 1A.

The video coding device 400 comprises ingress ports 410 (or input ports 410) and receiver units (Rx) 420 for receiving data; a processor, logic unit, or central processing unit (CPU) 430 to process the data; transmitter units (Tx) 440 and egress ports 450 (or output ports 450) for transmitting the data; and a memory 460 for storing the data. The video coding device 400 may also comprise optical-to-electrical (OE) components and electrical-to-optical (EO) components coupled to the ingress ports 410, the receiver units 420, the transmitter units 440, and the egress ports 450 for egress or ingress of optical or electrical signals.

The processor 430 is implemented by hardware and software. The processor 430 may be implemented as one or more CPU chips, cores (e.g., as a multi-core processor), FPGAs, ASICs, and DSPs. The processor 430 is in communication with the ingress ports 410, receiver units 420, transmitter units 440, egress ports 450, and memory 460. The processor 430 comprises a coding module 470. The coding module 470 implements the disclosed embodiments described above. For instance, the coding module 470 implements, processes, prepares, or provides the various coding operations. The inclusion of the coding module 470 therefore provides a substantial improvement to the functionality of the video coding device 400 and effects a transformation of the video coding device 400 to a different state.

Alternatively, the coding module 470 is implemented as instructions stored in the memory 460 and executed by the processor 430.

The memory 460 may comprise one or more disks, tape drives, and solid-state drives and may be used as an over-flow data storage device, to store programs when such programs are selected for execution, and to store instructions and data that are read during program execution. The memory 460 may be, for example, volatile and/or non-volatile and may be a  
5 read-only memory (ROM), random access memory (RAM), ternary content-addressable memory (TCAM), and/or static random-access memory (SRAM).

Fig. 5 is a simplified block diagram of an apparatus **500** that may be used as either or both of the source device 12 and the destination device 14 from Fig. 1 according to an exemplary  
10 embodiment.

A processor 502 in the apparatus 500 can be a central processing unit. Alternatively, the processor 502 can be any other type of device, or multiple devices, capable of manipulating or processing information now existing or hereafter developed. Although the disclosed implementations can be practiced with a single processor as shown, e.g., the processor 502,  
15 advantages in speed and efficiency can be achieved using more than one processor.

A memory 504 in the apparatus 500 can be a read only memory (ROM) device or a random access memory (RAM) device in an implementation. Any other suitable type of storage device can be used as the memory 504. The memory 504 can include code and data 506 that  
20 is accessed by the processor 502 using a bus 512. The memory 504 can further include an operating system 508 and application programs 510, the application programs 510 including at least one program that permits the processor 502 to perform the methods described here.

For example, the application programs 510 can include applications 1 through N, which further include a video coding application that performs the methods described here.  
25 The apparatus 500 can also include one or more output devices, such as a display 518. The display 518 may be, in one example, a touch sensitive display that combines a display with a touch sensitive element that is operable to sense touch inputs. The display 518 can be coupled to the processor 502 via the bus 512.

Although depicted here as a single bus, the bus 512 of the apparatus 500 can be composed of multiple buses. Further, the secondary storage 514 can be directly coupled to the other  
30 components of the apparatus 500 or can be accessed via a network and can comprise a single

integrated unit such as a memory card or multiple units such as multiple memory cards. The apparatus 500 can thus be implemented in a wide variety of configurations.

In the JVET-L1001 the draft text of VVC draft 3.0, MTS can be enable in the sequence level for inter and intra slice individually. When the MTS is off, DCT2 is supposed to be used as transform core. However, in the prior art such as JVET-M0303, JVET-M0140 or JVET-M0102, inferred DST7/DCT8 transform is introduced. There is no possibility to switch to purely DCT2 transform for all case. The present disclosure addresses the above-mentioned problem.

The present disclosure introduces an additional DCT2 enabled flag, which is used to infer whether only DCT2 transform core is used for all the case in the sequence, when DCT2 enabled flag is false, then the sequence level MTS enabled flag is further signaled. When DCT2 enabled flag is true, only DCT2 transform core is supposed to be used.

Introducing additional DCT2 enabled flag in the SPS to make the switch to DCT2 possible when interred MST tool is on.

7.3.2.1 Sequence parameter set RBSP syntax

	<b>Descriptor</b>
seq_parameter_set_rbsp( ) {	
...	ue(v)
<b>sps_dct2_enabled_flag</b>	
<b>if (! sps_dct2_enabled_flag) {</b>	
<b>sps_mts_intra_enabled_flag</b>	u(1)
<b>sps_mts_inter_enabled_flag</b>	u(1)
<b>}</b>	
...	u(1)
<b>}</b>	

In the JVET-L1001 the draft text of VVC draft 3.0, multiple transform selection (MTS) can be enable in the sequence level for inter and intra slice individually. When the MTS is off, DCT2 is supposed to be used as transform core. However, in the prior art such as JVET-M0303, JVET-M0140 or JVET-M0102, inferred DST7/DCT8 transform is introduced.

In the MTS sequence level off case, prior art is using DST7/DCT8 and DCT2 is adaptively applied depending on block shapes, positions or other features. However DCT2 is desirable for both encoder and decoder design. In other word, the switchability between DCT2,

inferred DST7 or DCT8 and MTS (RDO selected transform core) is designed in the present disclosure.

In this disclosure, a DCT2 enabled flag is introduced in the high level syntax. In order to address the mentioned problem in Section 1.1. The additional DCT2 enabled flag in the high level syntax is used to infer whether only DCT2 transform core is used for all the case in the sequence, when DCT2 enabled flag is false, then the sequence level MTS enabled flag is further signaled to inferred whether MTS is enabled for the sequence. When DCT2 enabled flag is true, only DCT2 transform core is supposed to be used.

10

For sequence level DCT2 enabled flag is disable case, sequence level MTS flag is further signaled as in the prior art of VVC draft 3.0 (JVET-L1001). Hence the inferred DST7DCT8 or adaptive transform core coding tool such as (JVET-M0303, JVET-M0140 or JVET-M0102) is used same as in the prior art.

15

For the sequence level DCT enabled flag is enabled case, only DCT2 is supposed to be used. Therefore, for the inferred DST7DCT8 or adaptive transform core coding tool such as (JVET-M0303, JVET-M0140 or JVET-M0102) is either inferred using DCT2 instead of DST7/DCT8 or disabled.

20

The first embodiment of the present disclosure  
 In the first embodiment, the sequence level DCT2 enabled flag is indicated in the sps as follow, the highlighted part is designed by the present disclosure. The encoder includes the indicator of DCT2 enabled flag into the bitstream, the decoder parsed the indicator of the DCT enable flag from the bitstream.

25

7.3.2.1 Sequence parameter set RBSP syntax

	<b>Descriptor</b>
seq_parameter_set_rbsp( ) {	
...	uc(v)
<b>sps_dct2_enabled_flag</b>	
<b>if (! sps_dct2_enabled_flag) {</b>	
<b>sps_mts_intra_enabled_flag</b>	u(1)
<b>sps_mts_inter_enabled_flag</b>	u(1)
<b>}</b>	
...	u(1)
<b>}</b>	

**sps\_dct2\_enabled\_flag** equal to 1 specifies that only DCT2 transform core is used for transform unit. **sps\_mts\_intra\_enabled\_flag** equal to 0 specifies that other transform cores out of DCT2 is possible to be used in the transform unit

- 5 **sps\_mts\_intra\_enabled\_flag** equal to 1 specifies that **tu\_mts\_flag** may be present in the residual coding syntax for intra coding units. **sps\_mts\_intra\_enabled\_flag** equal to 0 specifies that **tu\_mts\_flag** is not present in the residual coding syntax for intra coding units. When the **sps\_mts\_intra\_enabled\_flag** is not present, the **sps\_mts\_intra\_enabled\_flag** is inferred to be 0. **sps\_mts\_inter\_enabled\_flag** specifies that **tu\_mts\_flag** may be present in the residual coding syntax for inter coding units. **sps\_mts\_inter\_enabled\_flag** equal to 0 specifies that **tu\_mts\_flag** is not present in the residual coding syntax for inter coding units. When the **sps\_mts\_intra\_enabled\_flag** is not present, the **sps\_mts\_intra\_enabled\_flag** is inferred to be 0.

The DCT2 enabled flag, is further used in the low level syntax, for example in the shape adaptive transform selection case (JVET-M0303), the inferred DST7/DCT8 is used for short edge of rectangular block and DST7 is used for the square block when MTS flag is indicated as disabled in the sequence level. If the sequence level MTS is enabled for the sequence, the shape adaptiveness is applied in the case when MTS flag is zero and VTM would use DCT2 for both horizontal and vertical directions. In the case MTS flag is one, the VTM transform selection process is followed. All the three transforms used (DCT2, DST7 and DCT8) are identical to the ones defined in the current VTM.

In the proposed method, when DCT2 enabled flag is indicated as disabled, the adaptive core selection is keep same as the prior art

25 When the DCT2 enabled flag is indicated as enabled, only DCT2 could be used. The MTS function is inferred turned off. And the shape adaptive transform selection can only inferred use DCT2, in this embodiment it's same as disabling shape adaptive transform selection. The corresponding low-level syntax is as follow:

#### 30 8.4.4 Transformation process for scaled transform coefficients

##### 8.4.4.1 General

Inputs to this process are:

- a luma location (  $x_{TbY}$ ,  $y_{TbY}$  ) specifying the top-left sample of the current luma transform block relative to the top-left luma sample of the current picture,

- a variable  $nTbW$  specifying the width of the current transform block,
- a variable  $nTbH$  specifying the height of the current transform block,
- a variable  $cIdx$  specifying the colour component of the current block,
- an  $(nTbW) \times (nTbH)$  array  $d[x][y]$  of scaled transform coefficients with  
5  $x = 0..nTbW - 1, y = 0..nTbH - 1$ .

Output of this process is the  $(nTbW) \times (nTbH)$  array  $r[x][y]$  of residual samples with  
 $x = 0..nTbW - 1, y = 0..nTbH - 1$ .

The variable  $trTypeHor$  specifying the horizontal transform kernel and the variable  $trTypeVer$   
specifying the vertical transform kernel are derived in Table 8-11 depending on  
10  $mts\_idx[xTbY][yTbY][cIdx]$ . Variables  $trAdaptHorEnabled$  and  $trAdaptVerEnabled$  are  
derived as follows:

- if  $sps\_dct2\_enabled\_flag \ \&\& \ CuPredMode[xTbY][yTbY] == MODE\_INTRA$   
 $\ \&\& \ !(cIdx > 0 \ \&\& \ IntraPredModeC[xTbY][yTbY] > 66)$ :

$trAdaptSizeMin = 4$

15  $trAdaptSizeMax = cIdx == 0 ? 16 : 8$

$trAdaptHorEnabled = nTbW \geq trAdaptSizeMin \ \&\& \ nTbW \leq trAdaptSizeMax ? 1 :$

0

$trAdaptVerEnabled = nTbH \geq trAdaptSizeMin \ \&\& \ nTbH \leq trAdaptSizeMax ? 1 :$

0

- otherwise:

$trAdaptHorEnabled = 0$

$trAdaptVerEnabled = 0$

Variables  $trAdaptHor$  and  $trAdaptVer$  are derived as follows:

- if  $sps\_mts\_intra\_enabled\_flag$ :

25  $trAdaptHor = trAdaptHorEnabled \ \&\& \ nTbW < nTbH ? 1 : 0$

$trAdaptVer = trAdaptVerEnabled \ \&\& \ nTbH < nTbW ? 1 : 0$

- otherwise:

$trAdaptHor = trAdaptHorEnabled \ \&\& \ nTbW \leq nTbH ? 1 : 0$

$trAdaptVer = trAdaptVerEnabled \ \&\& \ nTbH \leq nTbW ? 1 : 0$

30

Table 8-11 – Specification of trTypeHor and trTypeVer depending on mts\_idx[ x ][ y ][ cIdx ]

mts_idx[ xTbY ][ yTbY ][ cIdx ]	trTypeHor	trTypeVer
-1	trAdaptHor	trAdaptVer
0	1	1
1	2	1
2	1	2
3	2	2

The second embodiment of the present disclosure

In the second embodiment, the sequence level DCT2 enabled flag is indicated in the sps as follow, the highlighted part is designed by the present disclosure. The encoder includes the indicator of DCT2 enabled flag into the bitstream, the decoder parsed the indicator of the DCT enable flag from the bitstream.

7.3.2.1 Sequence parameter set RBSP syntax

	Descriptor
seq_parameter_set_rbsp() {	
...	ue(v)
<b>sps_dct2_enabled_flag</b>	
<b>if (!sps_dct2_enabled_flag) {</b>	
<b>sps_mts_intra_enabled_flag</b>	u(1)
<b>sps_mts_inter_enabled_flag</b>	u(1)
⋮	
...	u(1)
}	

10

**sps\_dct2\_enabled\_flag** equal to 1 specifies that only DCT2 transform core is used for transform unit. **sps\_mts\_intra\_enabled\_flag** equal to 0 specifies that other transform cores out of DCT2 is possible to be used in the transform unit

15

**sps\_mts\_intra\_enabled\_flag** equal to 1 specifies that tu\_mts\_flag may be present in the residual coding syntax for intra coding units. **sps\_mts\_intra\_enabled\_flag** equal to 0 specifies that tu\_mts\_flag is not present in the residual coding syntax for intra coding units. When the **sps\_mts\_intra\_enabled\_flag** is not present, the **sps\_mts\_intra\_enabled\_flag** is inferred to be 0.

20

**sps\_mts\_inter\_enabled\_flag** specifies that tu\_mts\_flag may be present in the residual coding syntax for inter coding units. **sps\_mts\_inter\_enabled\_flag** equal to 0 specifies that tu\_mts\_flag is not present in the residual coding syntax for inter coding units. When the

sps\_mts\_intra\_enabled\_flag is not present, the sps\_mts\_intra\_enabled\_flag is inferred to be 0.

The DCT2 enabled flag, is further used in the low level syntax, for example in the sub block transform case (JVET-M0140), the inferred DST7/DCT8 is used depends on the position of the sub transform block. More specifically, the horizontal and vertical transforms for each SBT position is specified in Figure 6 and Figure 7. For example, the horizontal and vertical transforms for SBT-V position 0 is DCT-8 and DST-7, respectively. When one side of the residual TU is greater than 32, the corresponding transform is set as DCT-2. Therefore, the sub-block transform jointly specifies the TU tiling, cbf, and horizontal and vertical transforms of a residual block, which may be considered a syntax shortcut for the cases that the major residual of a block is at one side of the block.

In the proposed method, when DCT2 enabled flag is indicated as disabled, the sub block transform selection is keep same as the prior art

When the DCT2 enabled flag is indicated as enabled, only DCT2 could be used. The MTS function is inferred turned off. And the sub block transform core can only inferred use DCT2. The corresponding low level syntax is attached.

#### 8.4.4 Transformation process for scaled transform coefficients

##### 8.4.4.1 General

Inputs to this process are:

- a luma location (  $x_{TbY}, y_{TbY}$  ) specifying the top-left sample of the current luma transform block relative to the top-left luma sample of the current picture,
- a variable  $nTbW$  specifying the width of the current transform block,
- a variable  $nTbH$  specifying the height of the current transform block,
- a variable  $cIdx$  specifying the colour component of the current block,
- an  $(nTbW) \times (nTbH)$  array  $d[x][y]$  of scaled transform coefficients with  $x = 0..nTbW - 1, y = 0..nTbH - 1$ .

Output of this process is the  $(nTbW) \times (nTbH)$  array  $r[x][y]$  of residual samples with  $x = 0..nTbW - 1, y = 0..nTbH - 1$ .

If  $cu\_sbt\_flag[x_{TbY}][y_{TbY}]$  is equal to 1, the variable  $trTypeHor$  specifying the horizontal transform kernel and the variable  $trTypeVer$  specifying the vertical transform kernel are derived in Table depending on  $cu\_sbt\_horizontal\_flag[x_{TbY}][y_{TbY}]$  and  $cu\_sbt\_pos\_flag[x_{TbY}][y_{TbY}]$ .

Otherwise ( $cu\_sbt\_flag[x_{TbY}][y_{TbY}]$  is equal to 0), the variable  $trTypeHor$  specifying the

horizontal transform kernel and the variable trTypeVer specifying the vertical transform kernel are derived in Table 8-16 depending on mts\_idx[ xTbY ][ yTbY ][ cIdx ].

The variables nonZeroW and nonZeroH are derived as follows:

$$\text{nonZeroW} = \text{Min}( \text{nTbW}, 32 ) \tag{8-810}$$

$$5 \quad \text{nonZeroH} = \text{Min}( \text{nTbH}, 32 ) \tag{8-811}$$

The (nTbW)x(nTbH) array r of residual samples is derived as follows:

1. Each (vertical) column of scaled transform coefficients d[ x ][ y ] with x = 0..nonZeroW - 1, y = 0..nonZeroH - 1 is transformed to e[ x ][ y ] with x = 0..nonZeroW - 1, y = 0..nTbH - 1 by invoking the one-dimensional transformation process as specified in clause 8.4.4.2 for each column x = 0..nonZeroW - 1 with the height of the transform block nTbH, the non-zero height of the scaled transform coefficients nonZeroH, the list d[ x ][ y ] with y = 0..nonZeroH - 1 and the transform type variable trType set equal to trTypeVer as inputs, and the output is the list e[ x ][ y ] with y = 0..nTbH - 1.
- 10 2. The intermediate sample values g[ x ][ y ] with x = 0..nonZeroW - 1, y = 0..nTbH - 1 are derived as follows:

$$g[ x ][ y ] = \text{Clip3}( \text{CoeffMin}, \text{CoeffMax}, ( e[ x ][ y ] + 64 ) \gg 7 ) \tag{8-812}$$

3. Each (horizontal) row of the resulting array g[ x ][ y ] with x = 0..nonZeroW - 1, y = 0..nTbH - 1 is transformed to r[ x ][ y ] with x = 0..nTbW - 1, y = 0..nTbH - 1 by invoking the one-dimensional transformation process as specified in clause 8.4.4.2 for each row y = 0..nTbH - 1 with the width of the transform block nTbW, the non-zero width of the resulting array g[ x ][ y ] nonZeroW, the list g[ x ][ y ] with x = 0..nonZeroW - 1 and the transform type variable trType set equal to trTypeHor as inputs, and the output is the list r[ x ][ y ] with x = 0..nTbW - 1.

25 **Table 8-15 – Specification of trTypeHor and trTypeVer depending on cu\_sbt\_horizontal\_flag[ x ][ y ] and cu\_sbt\_pos\_flag[ x ][ y ]**

	cu_sbt_horizontal_flag [ xTbY ][ yTbY ] == 0		cu_sbt_horizontal_flag [ xTbY ][ yTbY ] == 1	
	cu_sbt_pos_flag [ xTbY ][ yTbY ] == 0	cu_sbt_pos_flag [ xTbY ][ yTbY ] == 1	cu_sbt_pos_flag [ xTbY ][ yTbY ] = = 0	cu_sbt_pos_flag [ xTbY ][ yTbY ] = = 1
trType Hor	sps_dct2_enabled_ flag?0 : 2	sps_dct2_enabled_ flag?0 : 1	sps_dct2_enabled_ flag  nTbW > 32 ?	sps_dct2_enabled_ flag  nTbW > 32 ?

			0 : 1	0 : 1
trTypeVer	sps_dct2_enabled_flag    nTbH > 32 ? 0 : 1	sps_dct2_enabled_flag    nTbH > 32 ? 0 : 1	sps_dct2_enabled_flag ? 0 : 2	sps_dct2_enabled_flag ? 0 : 1

**Table 8-16 – Specification of trTypeHor and trTypeVer depending on mts\_idx[ x ][ y ][ cIdx ]**

mts_idx[ xTbY ][ yTbY ][ cIdx ]	trTypeHor	trTypeVer
-1	0	0
0	1	1
1	2	1
2	1	2
3	2	2

**5 The third embodiment of the present disclosure**

In the third embodiment, the sequence level DCT2 enabled flag is indicated in the sps as follow, the highlighted part is designed by the present disclosure. The encoder includes the indicator of DCT2 enabled flag into the bitstream, the decoder parsed the indicator of the DCT enable flag from the bitstream.

10

**7.3.2.1 Sequence parameter set RBSP syntax**

seq_parameter_set_rbsp( ) {	<b>Descript or</b>
...	ue(v)
<b>sps_dct2_enabled_flag</b>	
<b>if (! sps_dct2_enabled_flag) {</b>	
<b>sps_mts_intra_enabled_flag</b>	u(1)
<b>sps_mts_inter_enabled_flag</b>	u(1)
<b>}</b>	
...	u(1)
<b>}</b>	

sps\_dct2\_enabled\_flag equal to 1 specifies that only DCT2 transform core is used for transform unit. sps\_mts\_intra\_enabled\_flag equal to 0 specifies that other transform cores out of DCT2 is possible to be used in the transform unit

5 sps\_mts\_intra\_enabled\_flag equal to 1 specifies that tu\_mts\_flag may be present in the residual coding syntax for intra coding units. sps\_mts\_intra\_enabled\_flag equal to 0 specifies that tu\_mts\_flag is not present in the residual coding syntax for intra coding units. When the sps\_mts\_intra\_enabled\_flag is not present, the sps\_mts\_intra\_enabled\_flag is inferred to be 0. sps\_mts\_inter\_enabled\_flag specifies that tu\_mts\_flag may be present in the residual coding  
 10 syntax for inter coding units. sps\_mts\_inter\_enabled\_flag equal to 0 specifies that tu\_mts\_flag is not present in the residual coding syntax for inter coding units. When the sps\_mts\_intra\_enabled\_flag is not present, the sps\_mts\_intra\_enabled\_flag is inferred to be 0.

The DCT2 enabled flag, is further used in the low level syntax, for example in the sub block  
 15 transform case (JVET-M0140), the inferred DST7/DCT8 is used depends on the position of the sub transform block. More specifically, the horizontal and vertical transforms for each SBT position is specified in Figure 6. For example, the horizontal and vertical transforms for SBT-V position 0 is DCT-8 and DST-7, respectively. When one side of the residual TU is greater than 32, the corresponding transform is set as DCT-2. Therefore, the sub-block  
 20 transform jointly specifies the TU tiling, cbf, and horizontal and vertical transforms of a residual block, which may be considered a syntax shortcut for the cases that the major residual of a block is at one side of the block.

In the proposed method, when DCT2 enabled flag is indicated as disabled, the sub block  
 25 transform selection is keep same as the prior art

When the DCT2 enabled flag is indicated as enabled, only DCT2 could be used. The MTS function is inferred turned off. And the sub block transform is inferred offs since not possible inferred MTS transform cores are available.

The corresponding syntax change on top of JVET-M0140 is as follow:

30 7.3.2.1 Sequence parameter set RBSP syntax

seq_parameter_set_rbsp( ) {	Descriptor
	r
sps_seq_parameter_set_id	ue(v)

...	
sps_dct2_enabled_flag	
if (!sps_dct2_enabled_flag) {	u(1)
sps_mts_intra_enabled_flag	
sps_mts_inter_enabled_flag	u(1)
sps_sbt_enable_flag	u(1)
}	
if (sps_sbt_enable_flag)	
sps_sbt_max_size_64_flag	u(1)
...	
rbsp_trailing_bits()	
}	

Embodiments of the present disclosure introduces the switchable DCT2 enabled sequence level indicator, which provide the possibility to switch to pure DCT2 transform core with the inferred transform tool for the whole sequence or slice. DCT2 is relative simple to compute and low case for the memory bandwidth compare to other transform core. In the prior art, the possibility of using simple DCT2 transform is cut off by the inferred transform core, with the present indicator the flexibility of switching between low cost/complexity and high performance is provided for both encoder and decoder. In the embodiments, both low level changes and high level changes possibility is provided, which guarantee the consistency and coding performance of the code with multiple variations.

In other words, the present disclosure provides: A method of video coding a block of a picture, comprising for a sample from a plurality of samples of the block: obtaining a residual signal resulting from inter- or intra-picture prediction; inferring use of a Discrete Cosine Transform type 2, DCT2, transform core for a sequence of the residual signal; processing the transformation of the block using the inferred transform core.

That is, the present disclosure introduces an additional DCT2 enabled flag, which is used to infer whether only DCT2 transform core is used for all the case in the sequence, when DCT2 enabled flag is false, then the sequence level MTS enabled flag is further signaled. When DCT2 enabled flag is true, only DCT2 transform core is supposed to be used. Introducing

additional DCT2 enabled flag in the SPS to make the switch to DCT2 possible when interred MST tool is on.

This is further illustrated in Fig. 8. In Fig. 8, in step 1601 a picture having blocks is provided.

5 In step 1602, for a sample from a plurality of samples of a block of the picture, it is obtained a residual signal resulting from inter- or intra-picture prediction. In step 1603, it is inferred use of a Discrete Cosine Transform type 2, DCT2, transform core for a sequence of the residual signal, wherein said residual signal was obtained in step 1602. In step 1604, it is processes the transformation of the block using the inferred transform core.

10

In the method according to the present disclosure, and as illustrated according to Fig. 8, use of DCT2 may be inferred from a sequence level DCT2 enabled flag in the Sequence Parameter Set, SPS.

15 In the method according to the present disclosure, and as illustrated according to Fig. 8, the sequence level DCT2 enabled flag is denoted `sps_dct2_enabled_flag`.

The present disclosure further provides an encoder 20 as illustrated in Fig. 9. The encoder 20 illustrated in Fig. 9 comprises an obtaining unit 22. The obtaining unit 22 may be configured to obtain a residual signal resulting from inter- or intra-picture prediction. Fig. 9 further illustrates the encoder 20 also comprises an inferring unit 24. The inferring unit 24 may be configured to infer use of a Discrete Cosine Transform type 2, DCT2, transform core for a sequence of the residual signal. Here, the residual signal may be obtained by the obtaining unit 22. The encoder 20 as illustrated in Fig. 9 further comprises a processing unit 26. Said processing unit 26 may be configured to process the transformation of the block using the inferred transform core. The transform core may be inferred by the inferring unit 24.

20 In the encoder 20 according to the present disclosure as illustrated in Fig. 9, the inferring unit 24 may be configured to infer use of DCT2 from a sequence level DCT2 enabled flag in the Sequence Parameter Set, SPS.

25 In the encoder 20 according to the present disclosure as illustrated in Fig. 9, the sequence level DCT2 enabled flag may be denoted `sps_dct2_enabled_flag`.

The present disclosure further provides a decoder 30 as illustrated in Fig. 10. The decoder 30 illustrated in Fig. 10 comprises an obtaining unit 32. The obtaining unit 32 may be configured to obtain a residual signal resulting from inter- or intra-picture prediction. Fig. 10 further illustrates the decoder 30 also comprises an inferring unit 34. The inferring unit 34 may be configured to infer use of a Discrete Cosine Transform type 2, DCT2, transform core for a sequence of the residual signal. Here, the residual signal may be obtained by the obtaining unit 32. The decoder 30 as illustrated in Fig. 10 further comprises a processing unit 36. Said processing unit 36 may be configured to process the transformation of the block using the inferred transform core. The transform core may be inferred by the inferring unit 34.

In the decoder 30, according to the present disclosure as illustrated in Fig. 10 the inferring unit 34 may be configured to infer use of DCT2 from a sequence level DCT2 enabled flag in the Sequence Parameter Set, SPS.

In the decoder 30 according to the present disclosure as illustrated in Fig. 10, the sequence level DCT2 enabled flag may be denoted `sps_dct2_enabled_flag`.

20

### Mathematical Operators

The mathematical operators used in this application are similar to those used in the C programming language. However, the results of integer division and arithmetic shift operations are defined more precisely, and additional operations are defined, such as exponentiation and real-valued division. Numbering and counting conventions generally begin from 0, e.g., "the first" is equivalent to the 0-th, "the second" is equivalent to the 1-th, etc.

### Arithmetic operators

The following arithmetic operators are defined as follows:

- + Addition
- − Subtraction (as a two-argument operator) or negation (as a unary prefix operator)
- \* Multiplication, including matrix multiplication
- $x^y$  Exponentiation. Specifies x to the power of y. In other contexts, such notation is

	used for superscripting not intended for interpretation as exponentiation.
/	Integer division with truncation of the result toward zero. For example, $7 / 4$ and $-7 / -4$ are truncated to 1 and $-7 / 4$ and $7 / -4$ are truncated to $-1$ .
÷	Used to denote division in mathematical equations where no truncation or rounding is intended.
$\frac{x}{y}$	Used to denote division in mathematical equations where no truncation or rounding is intended.
$\sum_{i=x}^y f(i)$	The summation of $f(i)$ with $i$ taking all integer values from $x$ up to and including $y$ .
$x \% y$	Modulus. Remainder of $x$ divided by $y$ , defined only for integers $x$ and $y$ with $x \geq 0$ and $y > 0$ .

### Logical operators

The following logical operators are defined as follows:

	$x \ \&\& \ y$	Boolean logical "and" of $x$ and $y$
	$x \    \ y$	Boolean logical "or" of $x$ and $y$
5	!	Boolean logical "not"
	$x \ ? \ y \ : \ z$	If $x$ is TRUE or not equal to 0, evaluates to the value of $y$ ; otherwise, evaluates to the value of $z$ .

### Relational operators

10 The following relational operators are defined as follows:

	>	Greater than
	>=	Greater than or equal to
	<	Less than
	<=	Less than or equal to
15	==	Equal to
	!=	Not equal to

When a relational operator is applied to a syntax element or variable that has been assigned the value "na" (not applicable), the value "na" is treated as a distinct value for the syntax element or variable. The value "na" is considered not to be equal to any other value.

20

### Bit-wise operators

The following bit-wise operators are defined as follows:

25	&	Bit-wise "and". When operating on integer arguments, operates on a two's complement representation of the integer value. When operating on a binary
----	---	---

argument that contains fewer bits than another argument, the shorter argument is extended by adding more significant bits equal to 0.

| Bit-wise "or". When operating on integer arguments, operates on a two's complement representation of the integer value. When operating on a binary argument that contains fewer bits than another argument, the shorter argument is extended by adding more significant bits equal to 0.

^ Bit-wise "exclusive or". When operating on integer arguments, operates on a two's complement representation of the integer value. When operating on a binary argument that contains fewer bits than another argument, the shorter argument is extended by adding more significant bits equal to 0.

x >> y Arithmetic right shift of a two's complement integer representation of x by y binary digits. This function is defined only for non-negative integer values of y. Bits shifted into the most significant bits (MSBs) as a result of the right shift have a value equal to the MSB of x prior to the shift operation.

x << y Arithmetic left shift of a two's complement integer representation of x by y binary digits. This function is defined only for non-negative integer values of y. Bits shifted into the least significant bits (LSBs) as a result of the left shift have a value equal to 0.

## 20 Assignment operators

The following arithmetic operators are defined as follows:

= Assignment operator

++ Increment, i.e.,  $x++$  is equivalent to  $x = x + 1$ ; when used in an array index, evaluates to the value of the variable prior to the increment operation.

-- Decrement, i.e.,  $x--$  is equivalent to  $x = x - 1$ ; when used in an array index, evaluates to the value of the variable prior to the decrement operation.

+= Increment by amount specified, i.e.,  $x += 3$  is equivalent to  $x = x + 3$ , and  $x += (-3)$  is equivalent to  $x = x + (-3)$ .

-= Decrement by amount specified, i.e.,  $x -= 3$  is equivalent to  $x = x - 3$ , and  $x -= (-3)$  is equivalent to  $x = x - (-3)$ .

## Range notation

The following notation is used to specify a range of values:

$x = y..z$   $x$  takes on integer values starting from  $y$  to  $z$ , inclusive, with  $x$ ,  $y$ , and  $z$  being integer numbers and  $z$  being greater than  $y$ .

Mathematical functions

5 The following mathematical functions are defined:

$$\text{Abs}(x) = \begin{cases} x & ; \quad x \geq 0 \\ -x & ; \quad x < 0 \end{cases}$$

$\text{Asin}(x)$  the trigonometric inverse sine function, operating on an argument  $x$  that is in the range of  $-1.0$  to  $1.0$ , inclusive, with an output value in the range of  $-\pi/2$  to  $\pi/2$ , inclusive, in units of radians

10  $\text{Atan}(x)$  the trigonometric inverse tangent function, operating on an argument  $x$ , with an output value in the range of  $-\pi/2$  to  $\pi/2$ , inclusive, in units of radians

$$\text{Atan2}(y, x) = \begin{cases} \text{Atan}\left(\frac{y}{x}\right) & ; \quad x > 0 \\ \text{Atan}\left(\frac{y}{x}\right) + \pi & ; \quad x < 0 \ \&\& \ y \geq 0 \\ \text{Atan}\left(\frac{y}{x}\right) - \pi & ; \quad x < 0 \ \&\& \ y < 0 \\ +\frac{\pi}{2} & ; \quad x = 0 \ \&\& \ y \geq 0 \\ -\frac{\pi}{2} & ; \quad \text{otherwise} \end{cases}$$

$\text{Ceil}(x)$  the smallest integer greater than or equal to  $x$ .

$$\text{Clip1}_Y(x) = \text{Clip3}(0, (1 \ll \text{BitDepth}_Y) - 1, x)$$

15  $\text{Clip1}_C(x) = \text{Clip3}(0, (1 \ll \text{BitDepth}_C) - 1, x)$

$$\text{Clip3}(x, y, z) = \begin{cases} x & ; \quad z < x \\ y & ; \quad z > y \\ z & ; \quad \text{otherwise} \end{cases}$$

$\text{Cos}(x)$  the trigonometric cosine function operating on an argument  $x$  in units of radians.

$\text{Floor}(x)$  the largest integer less than or equal to  $x$ .

$$20 \text{GetCurrMsb}(a, b, c, d) = \begin{cases} c + d & ; \quad b - a \geq d / 2 \\ c - d & ; \quad a - b > d / 2 \\ c & ; \quad \text{otherwise} \end{cases}$$

$\text{Ln}(x)$  the natural logarithm of  $x$  (the base- $e$  logarithm, where  $e$  is the natural logarithm base constant 2.718 281 828...).

$\text{Log2}(x)$  the base-2 logarithm of  $x$ .

$\text{Log10}(x)$  the base-10 logarithm of  $x$ .

$$25 \text{Min}(x, y) = \begin{cases} x & ; \quad x \leq y \\ y & ; \quad x > y \end{cases}$$

$$\text{Max}(x, y) = \begin{cases} x & ; \quad x \geq y \\ y & ; \quad x < y \end{cases}$$

$$\text{Round}(x) = \text{Sign}(x) * \text{Floor}(\text{Abs}(x) + 0.5)$$

$$\text{Sign}(x) = \begin{cases} 1 & ; \quad x > 0 \\ 0 & ; \quad x == 0 \\ -1 & ; \quad x < 0 \end{cases}$$

$\text{Sin}(x)$  the trigonometric sine function operating on an argument  $x$  in units of radians

5  $\text{Sqrt}(x) = \sqrt{x}$

$$\text{Swap}(x, y) = (y, x)$$

$\text{Tan}(x)$  the trigonometric tangent function operating on an argument  $x$  in units of radians

#### 10 Order of operation precedence

When an order of precedence in an expression is not indicated explicitly by use of parentheses, the following rules apply:

- Operations of a higher precedence are evaluated before any operation of a lower precedence.
- 15 – Operations of the same precedence are evaluated sequentially from left to right.

The table below specifies the precedence of operations from highest to lowest; a higher position in the table indicates a higher precedence.

- 20 For those operators that are also used in the C programming language, the order of precedence used in this Specification is the same as used in the C programming language.

Table: Operation precedence from highest (at top of table) to lowest (at bottom of table)

operations (with operands x, y, and z)
"x++", "x--"
"!x", "-x" (as a unary prefix operator)
$x^y$
"x * y", "x / y", "x ÷ y", " $\frac{x}{y}$ ", "x % y"
"x + y", "x - y" (as a two-argument operator), " $\sum_{i=x}^y f(i)$ "
"x << y", "x >> y"
"x < y", "x <= y", "x > y", "x >= y"
"x == y", "x != y"
"x & y"
"x   y"
"x && y"
"x    y"
"x ? y : z"
"x.y"
"x = y", "x += y", "x -= y"

Text description of logical operations

In the text, a statement of logical operations as would be described mathematically in the following form:

```

5      if( condition 0 )
        statement 0
      else if( condition 1 )
        statement 1
      ...
10     else /* informative remark on remaining condition */
        statement n

```

may be described in the following manner:

... as follows / ... the following applies:

- If condition 0, statement 0
- 15 - Otherwise, if condition 1, statement 1

- ...
- Otherwise (informative remark on remaining condition), statement n

Each "If ... Otherwise, if ... Otherwise, ..." statement in the text is introduced with "... as follows" or "... the following applies" immediately followed by "If ... ". The last condition of the "If ... Otherwise, if ... Otherwise, ..." is always an "Otherwise, ...". Interleaved "If ... Otherwise, if ... Otherwise, ..." statements can be identified by matching "... as follows" or "... the following applies" with the ending "Otherwise, ...".

10 In the text, a statement of logical operations as would be described mathematically in the following form:

```

if( condition 0a  &&  condition 0b )
    statement 0
else if( condition 1a  ||  condition 1b )
15     statement 1
...
else
    statement n

```

may be described in the following manner:

- 20 ... as follows / ... the following applies:
- If all of the following conditions are true, statement 0:
    - condition 0a
    - condition 0b
  - Otherwise, if one or more of the following conditions are true, statement 1:
    - 25 - condition 1a
    - condition 1b
    - ...
    - Otherwise, statement n

In the text, a statement of logical operations as would be described mathematically in the following form:

if( condition 0 )

statement 0

5 if( condition 1 )

statement 1

may be described in the following manner:

When condition 0, statement 0

When condition 1, statement 1

10

Although embodiments of the disclosure have been primarily described based on video coding, it should be noted that embodiments of the coding system 10, encoder 20 and decoder 30 (and correspondingly the system 10) and the other embodiments described herein may also be configured for still picture processing or coding, i.e. the processing or coding of an individual picture independent of any preceding or consecutive picture as in video coding. In general only inter-prediction units 244 (encoder) and 344 (decoder) may not be available in case the picture processing coding is limited to a single picture 17. All other functionalities (also referred to as tools or technologies) of the video encoder 20 and video decoder 30 may equally be used for still picture processing, e.g. residual calculation 204/304, transform 206, 15 quantization 208, inverse quantization 210/310, (inverse) transform 212/312, partitioning 262/362, intra-prediction 254/354, and/or loop filtering 220, 320, and entropy coding 270 and entropy decoding 304.

Embodiments, e.g. of the encoder 20 and the decoder 30, and functions described herein, e.g. with reference to the encoder 20 and the decoder 30, may be implemented in hardware, 25 software, firmware, or any combination thereof. If implemented in software, the functions may be stored on a computer-readable medium or transmitted over communication media as one or more instructions or code and executed by a hardware-based processing unit.

Computer-readable media may include computer-readable storage media, which corresponds to a tangible medium such as data storage media, or communication media including any 30 medium that facilitates transfer of a computer program from one place to another, e.g., according to a communication protocol. In this manner, computer-readable media generally may correspond to (1) tangible computer-readable storage media which is non-transitory or (2) a communication medium such as a signal or carrier wave. Data storage media may be any

available media that can be accessed by one or more computers or one or more processors to retrieve instructions, code and/or data structures for implementation of the techniques described in this disclosure. A computer program product may include a computer-readable medium.

5

By way of example, and not limiting, such computer-readable storage media can comprise RAM, ROM, EEPROM, CD-ROM or other optical disk storage, magnetic disk storage, or other magnetic storage devices, flash memory, or any other medium that can be used to store desired program code in the form of instructions or data structures and that can be accessed  
10 by a computer. Also, any connection is properly termed a computer-readable medium. For example, if instructions are transmitted from a website, server, or other remote source using a coaxial cable, fiber optic cable, twisted pair, digital subscriber line (DSL), or wireless technologies such as infrared, radio, and microwave, then the coaxial cable, fiber optic cable, twisted pair, DSL, or wireless technologies such as infrared, radio, and microwave are  
15 included in the definition of medium. It should be understood, however, that computer-readable storage media and data storage media do not include connections, carrier waves, signals, or other transitory media, but are instead directed to non-transitory, tangible storage media. Disk and disc, as used herein, includes compact disc (CD), laser disc, optical disc, digital versatile disc (DVD), floppy disk and Blu-ray disc, where disks usually  
20 reproduce data magnetically, while discs reproduce data optically with lasers. Combinations of the above should also be included within the scope of computer-readable media.

Instructions may be executed by one or more processors, such as one or more digital signal processors (DSPs), general purpose microprocessors, application specific integrated circuits  
25 (ASICs), field programmable logic arrays (FPGAs), or other equivalent integrated or discrete logic circuitry. Accordingly, the term “processor,” as used herein may refer to any of the foregoing structure or any other structure suitable for implementation of the techniques described herein. In addition, in some aspects, the functionality described herein may be provided within dedicated hardware and/or software modules configured for encoding and  
30 decoding, or incorporated in a combined codec. Also, the techniques could be fully implemented in one or more circuits or logic elements.

The techniques of this disclosure may be implemented in a wide variety of devices or apparatuses, including a wireless handset, an integrated circuit (IC) or a set of ICs (e.g., a

chip set). Various components, modules, or units are described in this disclosure to emphasize functional aspects of devices configured to perform the disclosed techniques, but do not necessarily require realization by different hardware units. Rather, as described above, various units may be combined in a codec hardware unit or provided by a collection of  
5 interoperative hardware units, including one or more processors as described above, in conjunction with suitable software and/or firmware.

CLAIMS

1. A method of video coding a block of a picture, comprising:  
 obtaining a residual signal resulting from inter- or intra-picture prediction;  
 5 inferring use of a Discrete Cosine Transform type 2, DCT2, transform core for a sequence  
 of the residual signal;  
 processing the transformation of the block using the inferred transform core.
2. The method according to claim 1, wherein use of DCT2 is inferred from a sequence level  
 10 DCT2 enabled flag in the Sequence Parameter Set, SPS.
3. The method according to claim 2, wherein the sequence level DCT2 enabled flag is  
 denoted `sps_dct2_enabled_flag`.
- 15 4. The method according to claim 2 or 3, wherein the sequence level DCT2 enabled flag is  
 comprised in a SPS level syntax as follows:

seq_parameter_set_rbsp( ) {	<b>Descriptor</b>
...	uc(v)
sps_dct2_enabled_flag	
if (! sps_dct2_enabled_flag) {	
sps_mts_intra_enabled_flag	u(1)
sps_mts_inter_enabled_flag	u(1)
}	
...	u(1)
}	

wherein `sps_dct2_enabled_flag` represents the sequence level DCT2 enabled flag.

- 20 5. The method according to claim 4, wherein the `sps_mts_intra_enabled_flag` equal to 1  
 specifies that `tu_mts_flag` may be present in the residual coding syntax for intra coding units;  
`sps_mts_intra_enabled_flag` equal to 0 specifies that `tu_mts_flag` is not present in the residual  
 coding syntax for intra coding units; and when the `sps_mts_intra_enabled_flag` is not present,  
 25 the `sps_mts_intra_enabled_flag` is inferred to be 0.
6. The method according to claim 4 or 5, wherein the `sps_mts_inter_enabled_flag` specifies

that tu\_mts\_flag may be present in the residual coding syntax for inter coding units; sps\_mts\_inter\_enabled\_flag equal to 0 specifies that tu\_mts\_flag is not present in the residual coding syntax for inter coding units; and when the sps\_mts\_intra\_enabled\_flag is not present, the sps\_mts\_intra\_enabled\_flag is inferred to be 0.

5

7. The method according to any one of claims 2 to 6,  
wherein the sequence level DCT2 enabled flag being equal to 1 specifies that DCT2 transform core is used for transformation.

10

8. The method according to any one of claims 2 to 7,  
wherein the sequence level DCT2 enabled flag being equal to 1 specifies that DCT2 transform core is used for transformation, only.

15

9. The method according to any one of claims 2 to 8, wherein the sequence level DCT2 enabled flag being equal to 1 specifies that DCT2 is used for both horizontal direction transformation as well as vertical direction transformation.

20

10. The method according to any one of claims 2 to 9, wherein the sequence level DCT2 enabled flag being equal to 1 specifies that DCT2 is used in sub block transformation.

11. The method according to claim 10, wherein in case one side of a residual Transform Unit, tu is greater than 32, a corresponding transform core is set as DCT2.

12. The method according to any one of claims 2 to 11, wherein in case the sequence level DCT2 enabled flag is equal to 1 specifies that the DCT2 transform core is used for transformation, only, both the sub block transform as well as Multiple Transform Selection, MTS, transform are inferred as off.

30

13. The method according to any one of claim 2 to 10,  
wherein the sequence level DCT2 enabled flag being equal to 0 specifies that other transform cores than DCT2 are used for the transformation.

14. The method according to claim 13,  
wherein the other transform cores comprise a Discrete Sine Transform type 7, DST7

and/or a Discrete Cosine Transform type 8, DCT8.

15. The method according to claim 13 or 14, wherein the sequence level DCT2 enabled flag being equal to 0

5 specifies that it is inferred using at least one of DST7 or DCT8 for transformation.

16. The method according to any one of claims 13 to 15,

wherein in case the sequence level DCT2 enabled flag being equal to 0, it is determined whether Multiple Transform Selection for Sequence Parameter Set is enabled via a flag.

10

17. The method according to claim 16,

wherein in case the `sps_mts_intra_enabled_flag` is present,

in case the `sps_mts_intra_enabled_flag` is equal to 1 it is specified that a Transform Unit, TU, Multiple Transform Selection, MTS flag, denote `tu_mts_flag`, is present in the residual coding syntax for intra coding units;

15

in case the `sps_mts_intra_enabled_flag` is equal to 0 it is specified that a `tu_mts_flag` is not present in the residual coding syntax for intra coding units;

wherein in case the `sps_mts_intra_enabled_flag` is not present, the `sps_mts_intra_enabled_flag` is inferred to be 0.

20

18. An encoder (20) comprising processing circuitry for carrying out the method according to any one of claims 1 to 17.

19. A decoder (30) comprising processing circuitry for carrying out the method according to any one of claims 1 to 17.

25

20. An decoder (20) comprising:

an obtaining unit, configured to obtain a residual signal resulting from inter- or intra-picture prediction;

30

an inferring unit, configured to infer use of a Discrete Cosine Transform type 2, DCT2, transform core for a sequence of the residual signal; and

a processing unit, configured to process the transformation of the block using the inferred transform core.

21. The decoder according to claim 20, wherein the inferring unit is configured to infer use of DCT2 from a sequence level DCT2 enabled flag in the Sequence Parameter Set, SPS.

22. The decoder according to claim 21, wherein the sequence level DCT2 enabled flag is denoted `sps_dct2_enabled_flag`.

23. The decoder according to claim 21 or 22, wherein the sequence level DCT2 enabled flag is comprised in a SPS level syntax as follows:

	<b>Descriptor</b>
<code>seq_parameter_set_rbsp( ) {</code>	
<code>...</code>	<code>ue(v)</code>
<code>  sps_dct2_enabled_flag</code>	
<code>  if (! sps_dct2_enabled_flag) {</code>	
<code>    sps_mts_intra_enabled_flag</code>	<code>u(1)</code>
<code>    sps_mts_inter_enabled_flag</code>	<code>u(1)</code>
<code>  }</code>	
<code>  ...</code>	<code>u(1)</code>
<code>}</code>	

wherein `sps_dct2_enabled_flag` represents the sequence level DCT2 enabled flag.

24. The decoder according to claim 21, wherein the `sps_mts_intra_enabled_flag` equal to 1 specifies that `tu_mts_flag` may be present in the residual coding syntax for intra coding units; `sps_mts_intra_enabled_flag` equal to 0 specifies that `tu_mts_flag` is not present in the residual coding syntax for intra coding units; and when the `sps_mts_intra_enabled_flag` is not present, the `sps_mts_intra_enabled_flag` is inferred to be 0.

25. The decoder according to claim 21 or 22, wherein the `sps_mts_inter_enabled_flag` specifies that `tu_mts_flag` may be present in the residual coding syntax for inter coding units; `sps_mts_inter_enabled_flag` equal to 0 specifies that `tu_mts_flag` is not present in the residual coding syntax for inter coding units; and when the `sps_mts_intra_enabled_flag` is not present, the `sps_mts_intra_enabled_flag` is inferred to be 0.

26. The decoder according to any one of claims 21 to 25, wherein the sequence level DCT2 enabled flag being equal to 1 specifies that DCT2

transform core is used for transformation.

27. The decoder according to any one of claims 21 to 26,  
wherein the sequence level DCT2 enabled flag being equal to 1 specifies that DCT2

5 transform core is used for transformation, only.

28. The decoder according to any one of claims 21 to 27, wherein the sequence level DCT2  
enabled flag being equal to 1 specifies that DCT2 is used for both horizontal as well as  
vertical direction transformation.

10

29. The decoder according to any one of claims 21 to 28, wherein the sequence level DCT2  
enabled flag being equal to 1 specifies that DCT2 is used in sub block transformation.

30. The decoder according to claim 29, wherein in case one side of a residual Transform Unit,  
15 tu is greater than 32, a corresponding transform is set as DCT2.

31. The decoder according to any one of claims 21 to 30, wherein in case the sequence level  
DCT2 enabled flag is equal to 1 specifies that the DCT2 transform core is used for  
transformation, only, both the sub block transform as well as Multiple Transform Selection,  
20 MTS, transform are inferred as off.

32. The decoder according to any one of claims 21 to 29,  
wherein the sequence level DCT2 enabled flag being equal to 0 specifies that other  
transform cores than DCT2 are used for the transformation.

25

33. The decoder according to claim 32,  
wherein the inferring unit is configured to infer using a Discrete Sine Transform type 7,  
DST7 and/or a Discrete Cosine Transform type 8, DCT8, for transformation.

30 34. The decoder according to claim 32 or 33, wherein the sequence level DCT2 enabled flag  
being equal to 0

specifies that it is inferred using DST7/DCT8 for transformation, only.

35. The decoder according to any one of claims 32 to 34,

wherein in case the sequence level DCT2 enabled flag being equal to 0, it is determined whether Multiple Transform Selection for Sequence Parameter Set is enabled via a flag.

36. The decoder according to claim 35,

5 wherein in case the `sps_mts_intra_enabled_flag` is present,  
 in case the `sps_mts_intra_enabled_flag` is equal to 1 it is specified that a Transform Unit, TU, Multiple Transform Selection, MTS flag, denote `tu_mts_flag`, is present in the residual coding syntax for intra coding units;  
 in case the `sps_mts_intra_enabled_flag` is equal to 0 it is specified that a  
 10 `tu_mts_flag` is not present in the residual coding syntax for intra coding units;  
 wherein in case the `sps_mts_intra_enabled_flag` is not present, the `sps_mts_intra_enabled_flag` is inferred to be 0.

37. An encoder (20) comprising:

15 an obtaining unit, configured to obtain a residual signal resulting from inter- or intra-picture prediction;  
 an inferring unit, configured to infer use of a Discrete Cosine Transform type 2, DCT2, transform core for a sequence of the residual signal; and  
 a processing unit, configured to process the transformation of the block using the inferred  
 20 transform core.

38. The encoder according to claim 37, wherein the inferring unit is configured to infer use of DCT2 from a sequence level DCT2 enabled flag in the Sequence Parameter Set, SPS.

25 39. The encoder according to claim 38, wherein the sequence level DCT2 enabled flag is denoted `sps_dct2_enabled_flag`.

40. The encoder according to claim 38 or 39, wherein the sequence level DCT2 enabled flag is comprised in a SPS level syntax as follows:

	<b>Descriptor</b>
<code>seq_parameter_set_rbsp() {</code>	
...	<code>ue(v)</code>
<code>sps_dct2_enabled_flag</code>	
<code>if (!sps_dct2_enabled_flag) {</code>	
<code>sps_mts_intra_enabled_flag</code>	<code>u(1)</code>
<code>sps_mts_inter_enabled_flag</code>	<code>u(1)</code>

}	
...	u(1)
}	

wherein `sps_dct2_enabled_flag` represents the sequence level DCT2 enabled flag.

41. The encoder according to claim 38, wherein the `sps_mts_intra_enabled_flag` equal to 1 specifies that `tu_mts_flag` may be present in the residual coding syntax for intra coding units; `sps_mts_intra_enabled_flag` equal to 0 specifies that `tu_mts_flag` is not present in the residual coding syntax for intra coding units; and when the `sps_mts_intra_enabled_flag` is not present, the `sps_mts_intra_enabled_flag` is inferred to be 0.
42. The encoder according to claim 38 or 39, wherein the `sps_mts_inter_enabled_flag` specifies that `tu_mts_flag` may be present in the residual coding syntax for inter coding units; `sps_mts_inter_enabled_flag` equal to 0 specifies that `tu_mts_flag` is not present in the residual coding syntax for inter coding units; and when the `sps_mts_intra_enabled_flag` is not present, the `sps_mts_intra_enabled_flag` is inferred to be 0.
43. The encoder according to any one of claims 38 to 42, wherein the sequence level DCT2 enabled flag being equal to 1 specifies that DCT2 transform core is used for transformation.
44. The encoder according to any one of claims 38 to 43, wherein the sequence level DCT2 enabled flag being equal to 1 specifies that DCT2 transform core is used for transformation, only.
45. The encoder according to any one of claims 38 to 44, wherein the sequence level DCT2 enabled flag being equal to 1 specifies that DCT2 is used for both horizontal as well as vertical directions in shape adaptive transform selection.
46. The encoder according to any one of claims 38 to 45, wherein the sequence level DCT2 enabled flag being equal to 1 specifies that DCT2 is used in sub block transformation.
47. The encoder according to claim 46, wherein in case one side of a residual Transform Unit,

tu is greater than 32, a corresponding transform is set as DCT2.

48. The encoder according to any one of claims 38 to 47, wherein in case the sequence level DCT2 enabled flag is equal to 1 specifies that the DCT2 transform core is used for transformation, only, both the sub block transform as well as Multiple Transform Selection, MTS, transform are inferred as off.

49. The encoder according to any one of claims 38 to 46, wherein the sequence level DCT2 enabled flag being equal to 0 specifies that other transform cores than DCT2 are used for the transformation.

50. The encoder according to claim 49, wherein the inferring unit is configured to infer using a Discrete Sine Transform type 7, DST7 and/or a Discrete Cosine Transform type 8, DCT8, for transformation.

51. The encoder according to claim 49 or 50, wherein the sequence level DCT2 enabled flag being equal to 0 specifies that it is inferred using DST7/DCT8 for transformation, only.

52. The encoder according to any one of claims 49 to 51, wherein in case the sequence level DCT2 enabled flag being equal to 0, it is determined whether Multiple Transform Selection for Sequence Parameter Set is enabled via a flag.

53. The encoder according to claim 52, wherein in case the `sps_mts_intra_enabled_flag` is present, in case the `sps_mts_intra_enabled_flag` is equal to 1 it is specified that a Transform Unit, TU, Multiple Transform Selection, MTS flag, denote `tu_mts_flag`, is present in the residual coding syntax for intra coding units;

in case the `sps_mts_intra_enabled_flag` is equal to 0 it is specified that a `tu_mts_flag` is not present in the residual coding syntax for intra coding units; wherein in case the `sps_mts_intra_enabled_flag` is not present, the `sps_mts_intra_enabled_flag` is inferred to be 0.

54. A computer program product comprising a program code for performing the method

according to any one of claims 1 to 17.

55. A decoder, comprising:

one or more processors; and

5 a non-transitory computer-readable storage medium coupled to the processors and storing programming for execution by the processors, wherein the programming, when executed by the processors, configures the decoder to carry out the method according to any one of claims 1 to 17.

10 56. An encoder, comprising:

one or more processors; and

15 a non-transitory computer-readable storage medium coupled to the processors and storing programming for execution by the processors, wherein the programming, when executed by the processors, configures the encoder to carry out the method according to any one of claims 1 to 17.

57. A computer-readable non-transitory medium storing a program, including instructions which when executed on a processor cause the processor to perform the method according to any of claims 1 to 17.

20

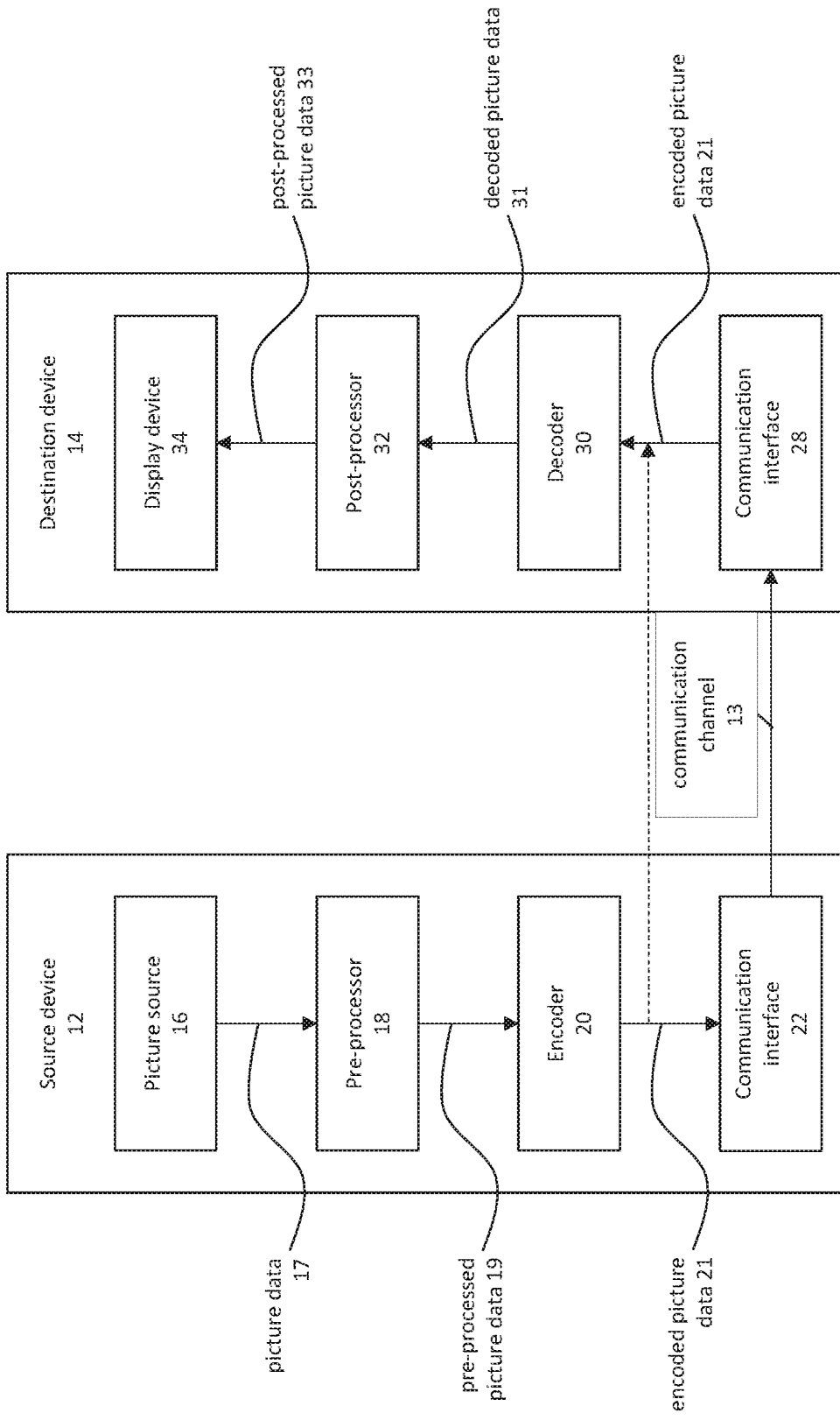

Fig. 1A

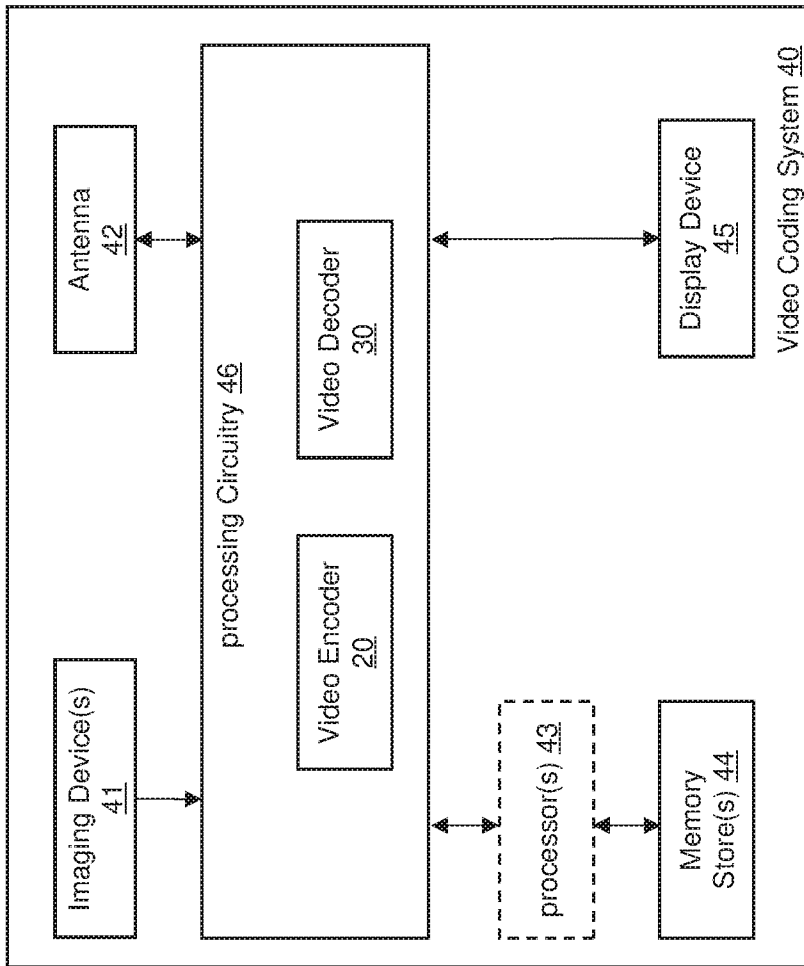

Fig. 1B

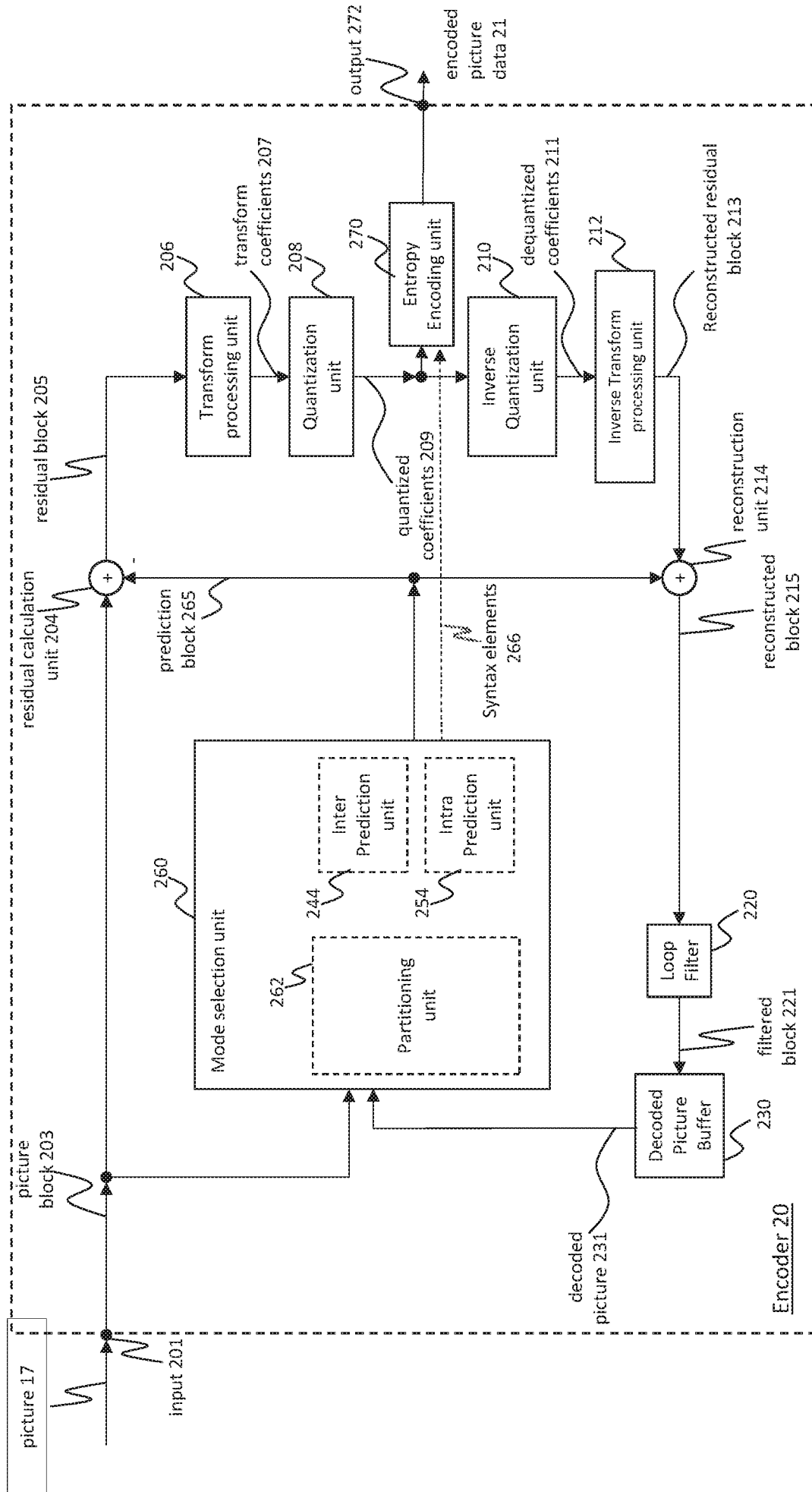

Fig. 2

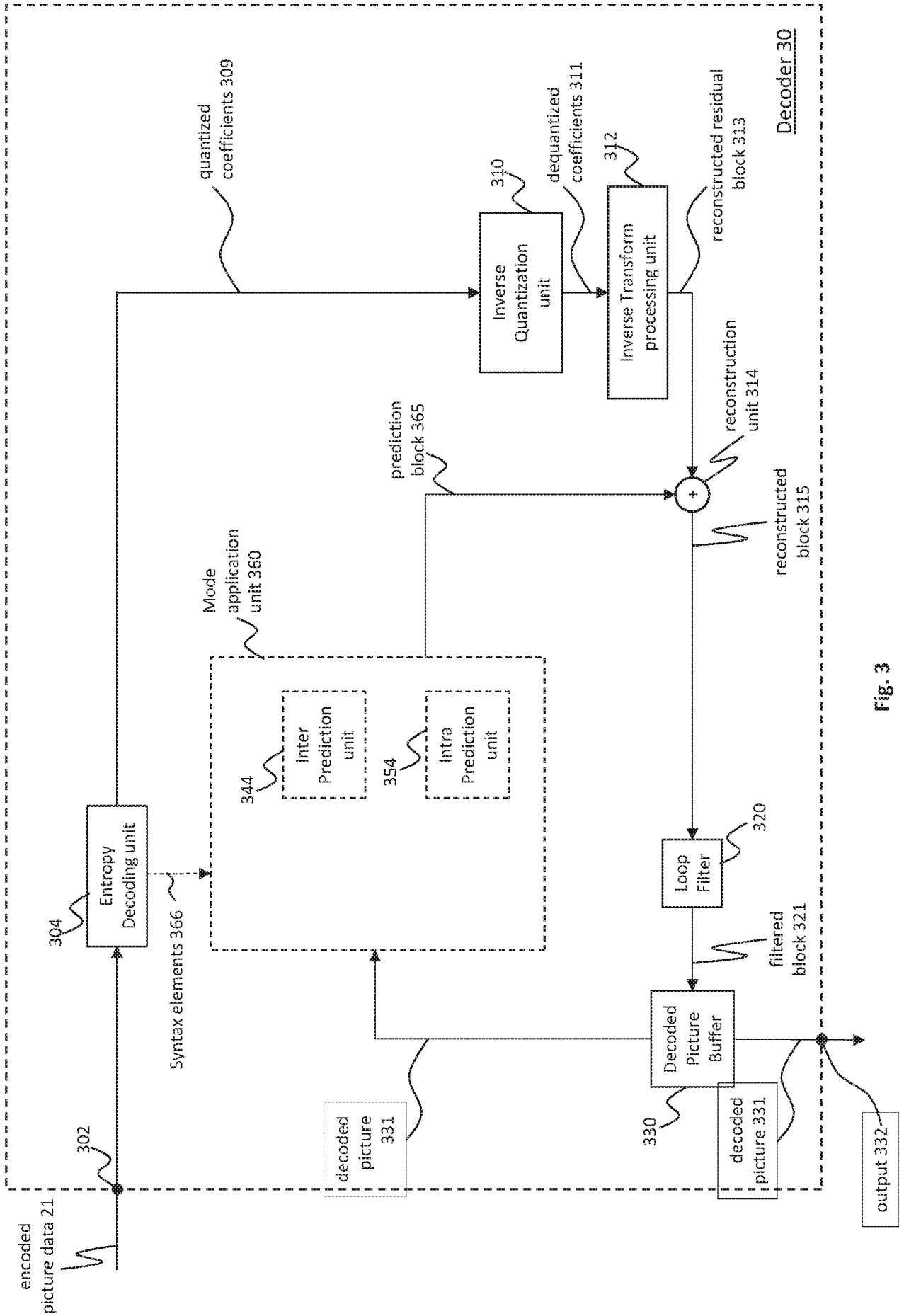

Fig. 3

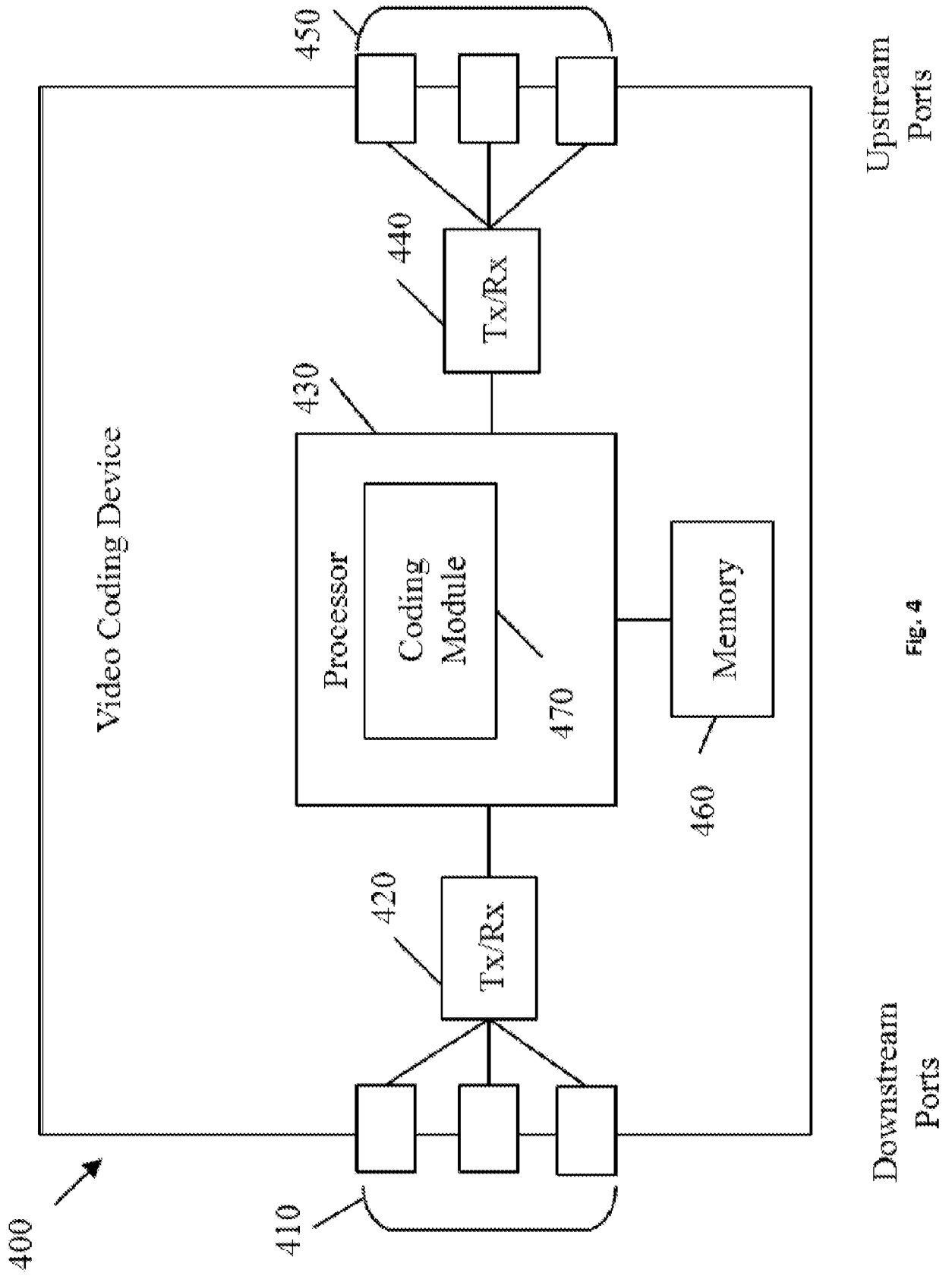

Fig. 4

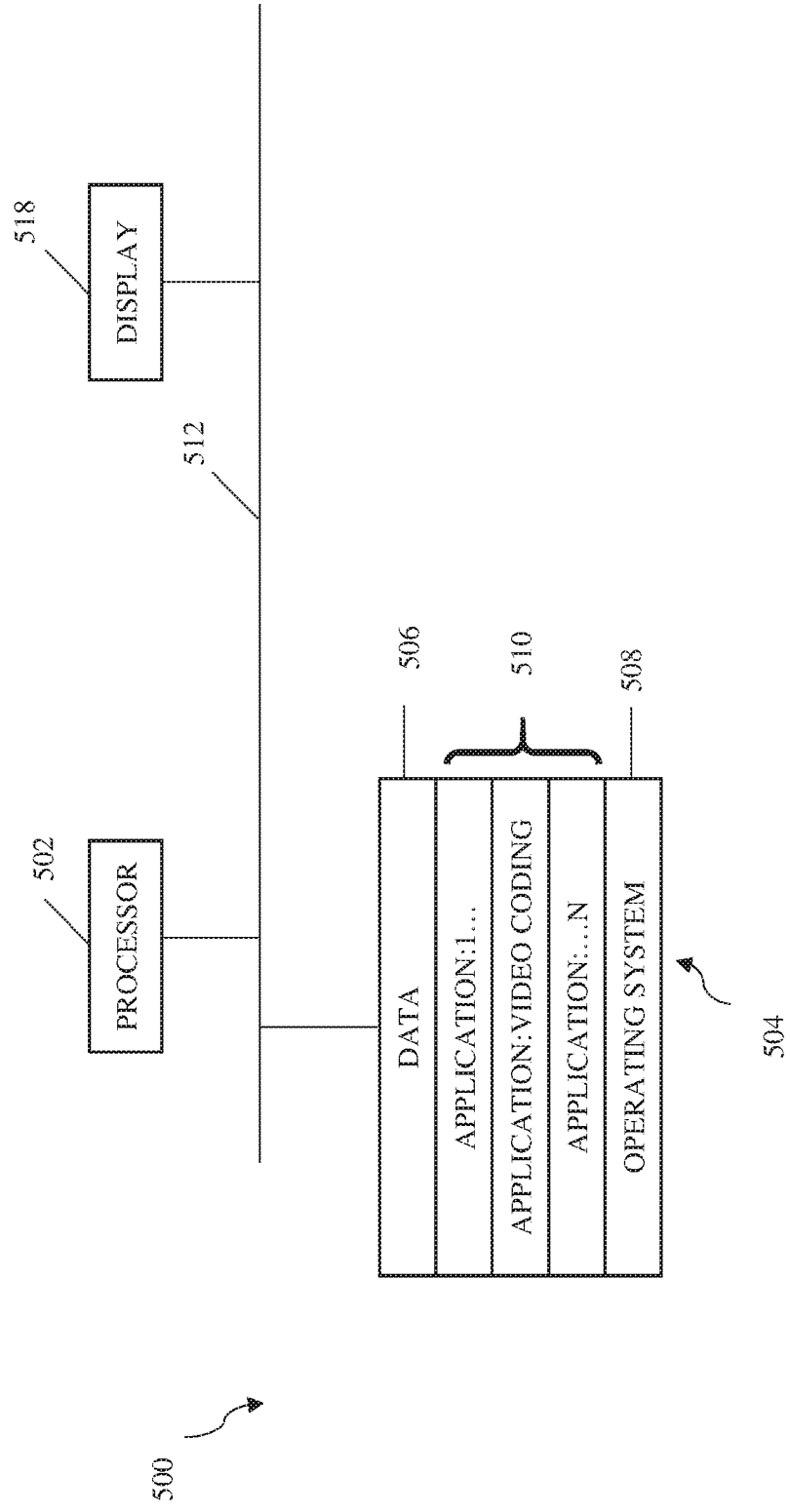

Fig. 5

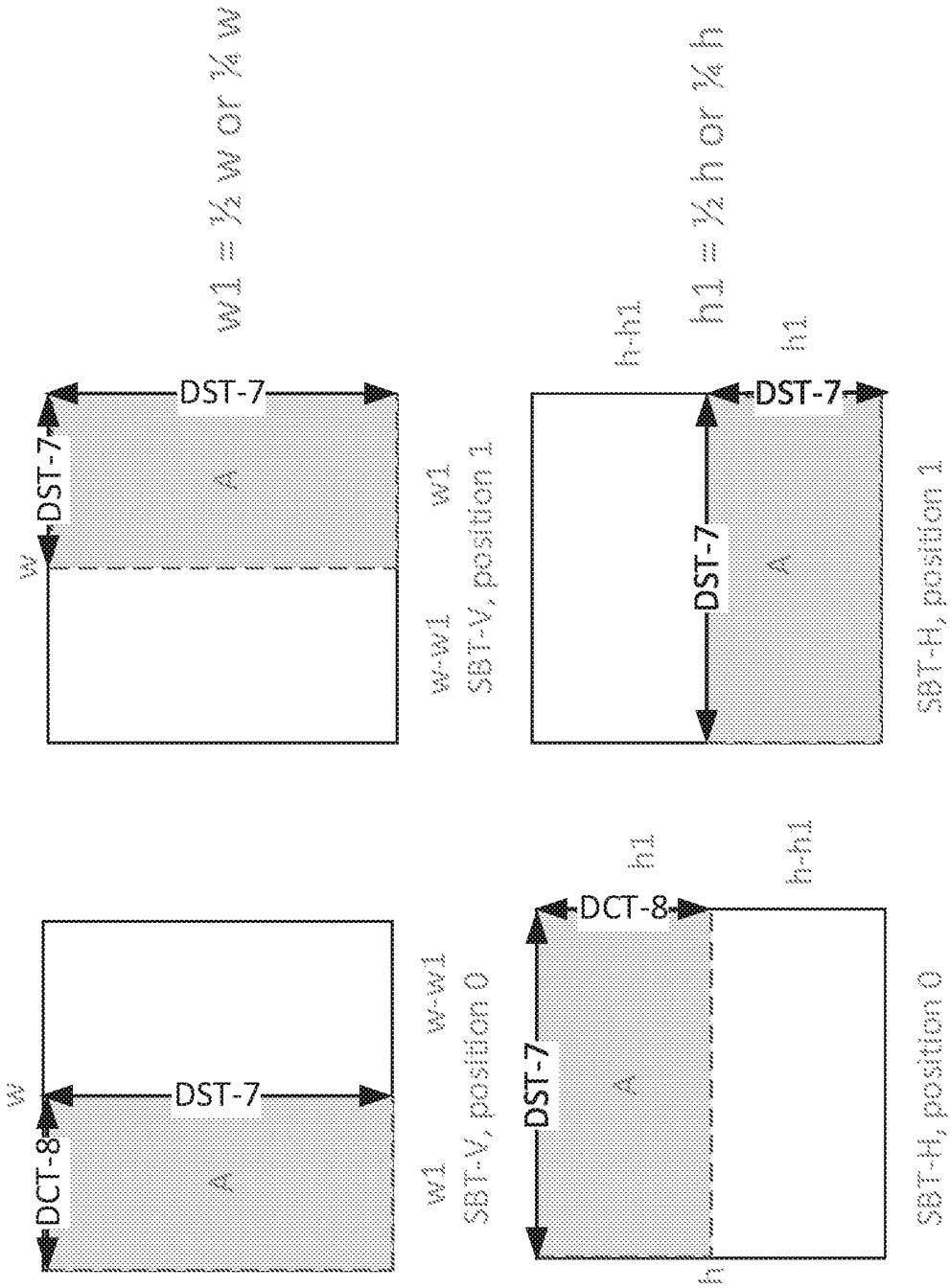

FIG. 6

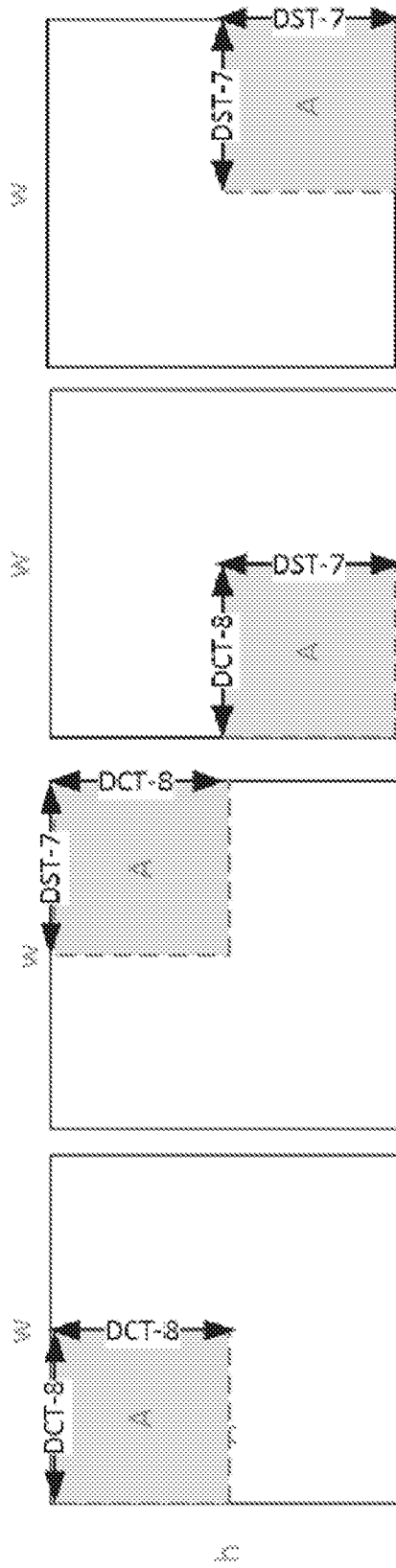

FIG. 7

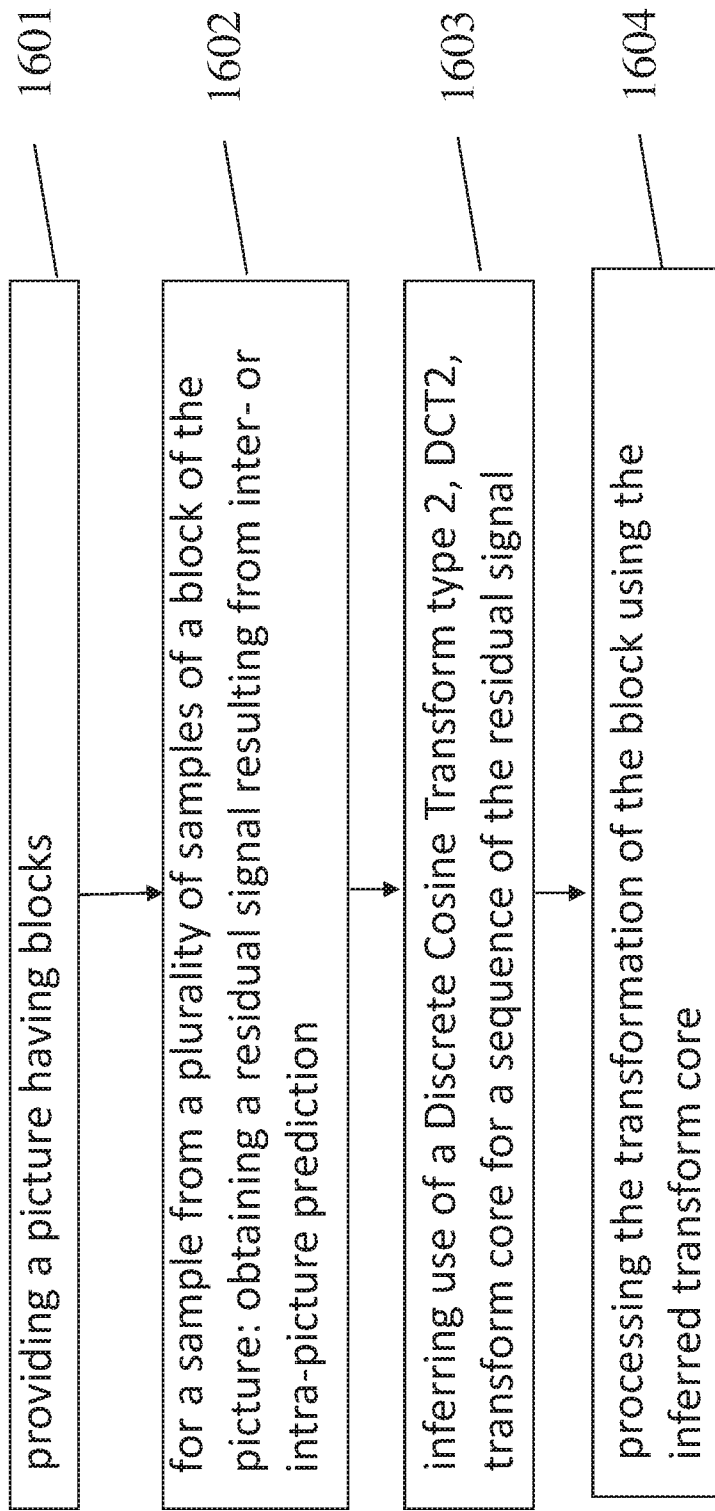

FIG. 8

20

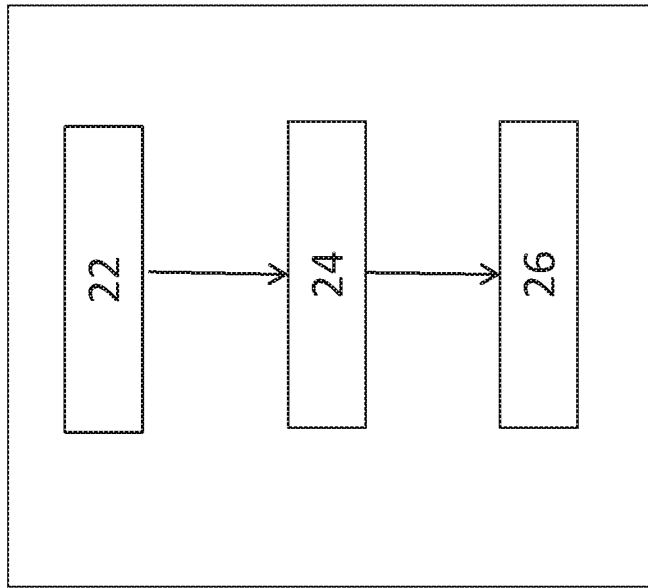

FIG. 9

30

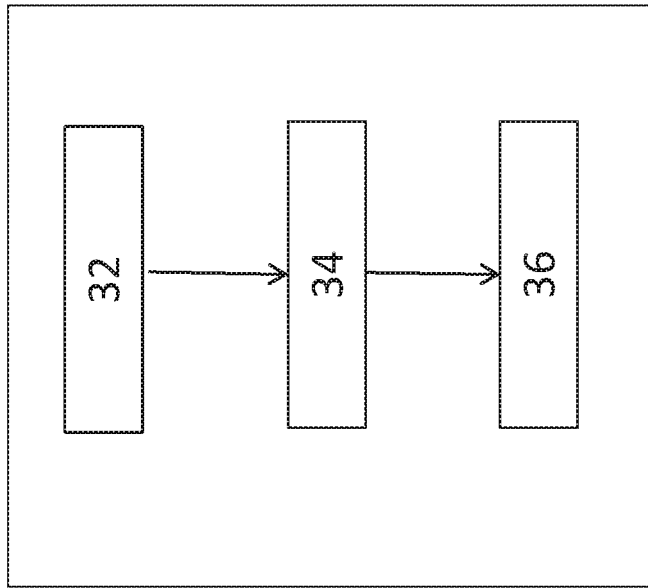

FIG. 10

## INTERNATIONAL SEARCH REPORT

International application No.

**PCT/CN2020/071591**

<b>A. CLASSIFICATION OF SUBJECT MATTER</b> H04N 19/13(2014.01)i  According to International Patent Classification (IPC) or to both national classification and IPC		
<b>B. FIELDS SEARCHED</b> Minimum documentation searched (classification system followed by classification symbols) H04N 19/-  Documentation searched other than minimum documentation to the extent that such documents are included in the fields searched  Electronic data base consulted during the international search (name of data base and, where practicable, search terms used) CNTXT, CNABS, CNKI, SIPOABS, DWPI, WOTXT: video cod+ encod+ residual intra- inter- picture predict+ discrete cosine transform DCT DST sequence core flag sequence parameter set SPS		
<b>C. DOCUMENTS CONSIDERED TO BE RELEVANT</b>		
Category*	Citation of document, with indication, where appropriate, of the relevant passages	Relevant to claim No.
X	US 2018332289 A1 (MEDIATEK INC.) 15 November 2018 (2018-11-15) description paragraphs [0004] to [0092]	1-57
A	US 2017295380 A1 (MEDIATEK SINGAPORE PTE. LTD.) 12 October 2017 (2017-10-12) the whole document	1-57
A	CN 109076243 A (SHARP KABUSHIKI KAISHA) 21 December 2018 (2018-12-21) the whole document	1-57
<input type="checkbox"/> Further documents are listed in the continuation of Box C. <input checked="" type="checkbox"/> See patent family annex.		
<p>* Special categories of cited documents:</p> <p>“A” document defining the general state of the art which is not considered to be of particular relevance</p> <p>“E” earlier application or patent but published on or after the international filing date</p> <p>“L” document which may throw doubts on priority claim(s) or which is cited to establish the publication date of another citation or other special reason (as specified)</p> <p>“O” document referring to an oral disclosure, use, exhibition or other means</p> <p>“P” document published prior to the international filing date but later than the priority date claimed</p> <p>“T” later document published after the international filing date or priority date and not in conflict with the application but cited to understand the principle or theory underlying the invention</p> <p>“X” document of particular relevance; the claimed invention cannot be considered novel or cannot be considered to involve an inventive step when the document is taken alone</p> <p>“Y” document of particular relevance; the claimed invention cannot be considered to involve an inventive step when the document is combined with one or more other such documents, such combination being obvious to a person skilled in the art</p> <p>“&amp;” document member of the same patent family</p>		
Date of the actual completion of the international search <b>07 April 2020</b>		Date of mailing of the international search report <b>14 April 2020</b>
Name and mailing address of the ISA/CN <b>National Intellectual Property Administration, PRC 6, Xitucheng Rd., Jimen Bridge, Haidian District, Beijing 100088 China</b> Facsimile No. <b>(86-10)62019451</b>		Authorized officer <b>LI, Qiong</b>  Telephone No. <b>86-(010)-62412166</b>

**INTERNATIONAL SEARCH REPORT**  
**Information on patent family members**

International application No.

**PCT/CN2020/071591**

Patent document cited in search report			Publication date (day/month/year)	Patent family member(s)			Publication date (day/month/year)
US	2018332289	A1	15 November 2018	TW	I669948	B	21 August 2019
				CN	109089117	A	25 December 2018
				TW	201902216	A	01 January 2019
US	2017295380	A1	12 October 2017	EP	3430805	A4	11 December 2019
				WO	2017173997	A1	12 October 2017
				EP	3430805	A1	23 January 2019
				TW	201743612	A	16 December 2017
				CN	109076221	A	21 December 2018
				WO	2017173593	A1	12 October 2017
				TW	I619375	B	21 March 2018
				IN	201827040651	A	12 July 2019
CN	109076243	A	21 December 2018	US	2019149822	A1	16 May 2019
				EP	3453181	A1	13 March 2019
				EP	3453181	A4	01 May 2019
				WO	2017191782	A1	09 November 2017