

(19) World Intellectual Property Organization  
International Bureau



(43) International Publication Date  
8 July 2010 (08.07.2010)

PCT

(10) International Publication Number  
**WO 2010/077144 A1**

(51) International Patent Classification:  
A61F 5/00 (2006.01)

(21) International Application Number:  
PCT/NL2010/050002

(22) International Filing Date:  
5 January 2010 (05.01.2010)

(25) Filing Language: English

(26) Publication Language: English

(30) Priority Data:  
2002396 5 January 2009 (05.01.2009) NL

(71) Applicant (for all designated States except US): **MMD PRODUCTS B.V.** [NL/NL]; Westvest 145, NL-2611 AZ Delft (NL).

(72) Inventor; and

(75) Inventor/Applicant (for US only): **MAGERMANS, Marcel, Peter** [NL/NL]; Rijsbes 101, NL-2498 AP Den Haag (NL).

(74) Agent: **KETELAARS, Maarten**; J.W. Frisolaan 13, NL-2517 JS The Hague (NL).

(81) Designated States (unless otherwise indicated, for every kind of national protection available): AE, AG, AL, AM,

AO, AT, AU, AZ, BA, BB, BG, BH, BR, BW, BY, BZ, CA, CH, CL, CN, CO, CR, CU, CZ, DE, DK, DM, DO, DZ, EC, EE, EG, ES, FI, GB, GD, GE, GH, GM, GT, HN, HR, HU, ID, IL, IN, IS, JP, KE, KG, KM, KN, KP, KR, KZ, LA, LC, LK, LR, LS, LT, LU, LY, MA, MD, ME, MG, MK, MN, MW, MX, MY, MZ, NA, NG, NI, NO, NZ, OM, PE, PG, PH, PL, PT, RO, RS, RU, SC, SD, SE, SG, SK, SL, SM, ST, SV, SY, TH, TJ, TM, TN, TR, TT, TZ, UA, UG, US, UZ, VC, VN, ZA, ZM, ZW.

(84) Designated States (unless otherwise indicated, for every kind of regional protection available): ARIPO (BW, GH, GM, KE, LS, MW, MZ, NA, SD, SL, SZ, TZ, UG, ZM, ZW), Eurasian (AM, AZ, BY, KG, KZ, MD, RU, TJ, TM), European (AT, BE, BG, CH, CY, CZ, DE, DK, EE, ES, FI, FR, GB, GR, HR, HU, IE, IS, IT, LT, LU, LV, MC, MK, MT, NL, NO, PL, PT, RO, SE, SI, SK, SM, TR), OAPI (BF, BJ, CF, CG, CI, CM, GA, GN, GQ, GW, ML, MR, NE, SN, TD, TG).

Published:

- with international search report (Art. 21(3))
- before the expiration of the time limit for amending the claims and to be republished in the event of receipt of amendments (Rule 48.2(h))

(54) Title: CHEST SUPPORT BELT

Fig 1

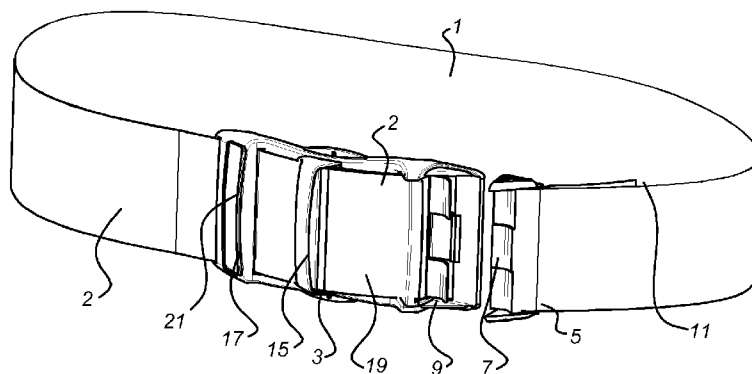

(57) Abstract: This invention relates to a chest support belt for wearing around a chest of a human being, comprising a strap that is, in use, connected with a first end to a connector end part of a base member, a second end of the strap being attached to a sliding grip and being guided from a guide end part of the base member, which guide end part is situated opposite to the connector end part, over a guide surface of the base member, in the direction of the connector end part to a roller member, and along the roller member back in the direction of the guide end part, wherein the sliding grip can slide along the base member, the base member comprising near the guide end part a fixed grip that is fixed to the base member, which fixed grip in an unextended state of the strap is situated at a distance of between 5 and 25 cm, preferably between 10 and 20 cm from the sliding grip.



WO 2010/077144 A1

## Chest support belt

### Field of the invention

5 The invention relates to a chest support belt, which can be worn around the chest of a patient that has undergone surgery to the chest. When a patient undergoes surgery to the chest, such as for instance heart surgery, the ribs of the patient may need to be cut along the sternum and be re-attached using wire, after completion of the heart surgery. The resulting trauma will need to cure over the period of several weeks. During this  
10 time, specific movements of the patient such as getting into an upright position, getting out of bed or sneezing, are very painful as the chest injury is placed under stress.

### Background of the invention

15 In order to prevent a painful expansion of the chest, a chest immobilising support belt is known from EP 0 260 351, wherein a harness is described having a belt that partly encircles the chest. The belt is supported by shoulder straps on the patient and has two free ends, each with a handle that can be gripped by a patient with one hand in order to tighten the belt and to relieve the stress from the chest.

20

The known chest immobilising strap has as a disadvantage that the position of the end parts of the belt is not defined and that a separate shoulder strap is required for properly positioning the strap on the patient. This results in a strap that is difficult to apply and to a large degree of visibility of the strap, which may negatively affect the appearance  
25 of the patient. Furthermore, as the ends of the strap are free to move independently, the pull direction of the known strap is not defined, such that a restricting squeezing force may not be applied in an effective as possible manner.

Accordingly, it is an object of the invention to provide a chest support strap which may  
30 be easily attached around the chest of a patient and that can be operated in an easy one-handed manner. It is a further object of the invention to provide a strap that can be worn inconspicuously by the patient. It is again an object to provide a strap that can be fixed in a squeezing position and that can be quickly released.

### Summary of the invention

Hereto the chest support belt according to the invention comprises a strap that is, in use, connected with a first end to a connector end part of a base member, a second end of  
5 the strap being attached to a sliding grip and being guided from a guide end part of the base member, which guide end part is situated opposite to the connector end part, over a guide surface of the base member, in the direction of the connector end part to a roller member, and along the roller member back in the direction of the guide end part, wherein the sliding grip can slide along the base member, the base member comprising  
10 near the guide end part a fixed grip that is fixed to the base member, which fixed grip in an untensioned state of the strap is situated at a distance of between 5 and 25 cm, preferably between 10 and 20 cm from the sliding grip.

By attaching both ends of the strap and guiding one end via a loop on the base member  
15 back to wards the guide end part of the gripping member, the patient can easily place the strap around the chest in an untensioned state, and can by one-handed gripping the sliding grip and the fixed grip on the base member, squeeze his fingers towards his palm to tighten the strap by pulling it around the roller member along the base member. In this manner, a defined pull force can be exerted on the chest. When the strain on the  
20 chest has disappeared, for instance after sneezing, the patient can release the gripping parts of the strap which can then relax and expand back to its larger circumferential dimension. By using a closed strap around the chest of the patient, the belt of the present invention can remain in its proper position without the need for additional  
shoulder straps.

25

In one embodiment, the sliding grip comprises a slit through which the strap is guided, the slit having about the same width as the width of the strap. By sliding the grip over the strap, the strap functions as a rails and the width of the grip can remain about the same as the width of the strap. Furthermore, guiding the sliding grip over the strap  
30 instead of along the base member section, provides a fail safe and simple mechanism, which avoids jamming and tilting of the base member. The strap may be guided through a second slit in the base member from the guide end part towards the roller member.

For easy coupling of the chest support belt, the base member may near the connector end part have a first connector member, which cooperates with a second connector member attached to the first end of the strap. The strap can be fixed around the chest in an easy and low-force manner.

In order to be able to keep the belt in a tensioned state and using both hands, the base member of a chest support belt according to the invention may have a pivoting lever near the roller member, which lever can be pivoted with a clamping surface into clamping engagement with the roller member.

To keep the base member clear from the underlying wound, the base member may have a curved surface with the first and second ends defining a support surface and with a middle section spaced at a distance from the support surface.

15

Fig. 1 shows a three-dimensional view of the chest support belt according to the invention in a detached state,

Fig. 2 shows a cross-sectional detail of the base member and grips of the support belt shown in fig. 1,

Fig. 3 shows a perspective view of the base member and connector members in the closed state,

Fig. 4 schematically shows the tensioning operation of the chest support belt after applying the belt to the chest of a patient,

Fig. 5 schematically shows the locking function of the chest support belt of the present invention.

Fig 1 shows a chest support belt 1 having a strap 2 and a base member 3. The strap 2 has at a first end 5 a connector member 7 which can be attached to connector end part 9 of the base member 3. The strap 2 furthermore comprises length adjustment means 11, not shown in detail, at which the strap 2 is looped along a buckle and fixed onto itself via a Velcro™ fastener. At a second end 19, the strap is connected in a sliding manner to the base member 3.

30

After having adjusted to the right length, depending on the size of the chest of the patient, prior to first time use, the strap 2 can be closed by engagement of the first connector member 7 with the second connector member 13, which simply clicks in place. Tightening of the belt 1 can occur by one-handed operation of the sliding grip 15 and moving this sliding grip 15 towards the fixed grip 17 on the base member 3. When  
5 tightening the strap 2, the patient puts the palm of his hand against the fixed grip 17 while hooking his fingertips of 3 or 4 fingers behind the upstanding edge of the sliding grip 15 and squeezes his hand closed. Hereby the second end 19 of the strap 2 is pulled around a roller member on the base in the direction of the guide end part 21 of the base  
10 member 3 and the strap 2 is tightened around the chest of the patient.

Figure 2 shows the base member 3 being provided near the connector end part 9 with first connector member 13 comprising a first guiding projection 22, a ledge 23 and a ridge 24. Upon connection, the lip 25 of the first connector member 7 can be slid under  
15 the projection 22, such that the slit 26 accommodates the ledge 23 and the sharp ledge 23 engages with the vertical side 27 of the first connector member 7.

The second end of the strap 2 is guided via slits 30,31 in the fixed grip 17 along a curved guide surface 33 to roller member 35. The roller member 35 can be a metal  
20 cylindrical pin that is fixed or that can be rotatably connected to a support on the base member 3. The pin can have a smooth surface in case it is fixed or may be profiled when it is mounted in a rotating manner. The end section of the strap 2 is looped back along the roller member 35 in the direction of the fixed grip 17 and is attached to the sliding grip 15. The sliding grip 15 can be moved over the guide surface 33 along the  
25 strap 2 that passes through a slit 38 in the sliding grip 15, which is about the same width as the width of the strap 2.

A stop member 39 is provided on the strap 2 in order to block movement of the sliding grip 15 such that the distance D between the fixed grip 17 and the sliding grip 15 is no  
30 longer than the span of a grip of a patient, which may, depending on the size of the hands of the patient, lie between 5 and 25 cm and preferably be about 10 cm.

A pivoting lever 42 is attached in a pivot point 43 and can be pulled in the direction of the arrow L by a patient, to bring a clamping surface 44 into engagement with the strap 2 and clamps the strap against the roller member 35. After releasing the lever 42, it remains in an upright position and keeps the strap 2 in a tightened state around the patient's chest, such that the patient has two hands available for other tasks than squeezing of the strap. The tension on the strap can be quickly released by pressing down upon the lever 42.

The base member 3 is of hollow curved shape and has first and second ends 50,51 which are supported on the chest and a middle section 52 that is spaced away from a flat support surface 53 (indicated with the dashed line in the drawing) in order to prevent the base member 3 from contacting the underlying wound to the chest.

Figure 3 shows the base member 3 in an operative state in which the first and second connector members 7, 13 are coupled.

Figure 4 schematically shows how by moving the sliding grip 15 in the direction of the arrow T, the strap 2 is pulled around the roller member 35 in the direction P of the fixed grip 17, such that the belt 2 is tightened. The ergonomic design of the grips 15 and 17 allow the patient to easily hold the strap in a tightened state for a longer period of time, until the strain on the chest has been relieved.

Figure 5 schematically shows the functioning of the pivoting lever 42, which is operated by pulling it upward in the direction of the arrow L to clamp the strap 2 against the roller member 35. After releasing the lever 42 it remains in clamping engagement with the roller member 35 such that the strap 2 remains under tension even when the grips 15 and 17 are released.

**Claims**

1. Chest support belt (1) for wearing around a chest of a human being,  
comprising a strap (2) that is, in use, connected with a first end (5) to a  
5 connector end part (9) of a base member (3), a second end (19) of the strap  
(2) being attached to a sliding grip (15) and being guided from a guide end  
(21) part of the base member (3), which guide end part is situated opposite  
to the connector end part (9), over a guide surface (33) of the base member,  
in the direction of the connector end part (9) to a roller member (35), and  
10 along the roller member (35) back in the direction of the guide end part (21),  
wherein the sliding grip (15) can slide along the base member (3), the base  
member comprising near the guide end part (21) a fixed grip (17) that is  
fixed to the guide surface (33) of the base member (3), which fixed grip (17)  
in an untensioned state of the strap (2) is situated at a distance (D) of  
15 between 5 and 25 cm, preferably between 10 and 20 cm from the sliding  
grip (15).
2. Chest support (1) belt according to claim 1, wherein the sliding grip (15)  
comprises a slit (38) through which the strap (2) is guided, the slit having  
20 about the same width as the width of the strap.
3. Chest support (1) belt according to claim 1 or 2, wherein the strap (2) is  
guided through a second slit (30,31) in the base member (3) from the guide  
end part (21) towards the roller member (35).  
25
4. Chest support belt (1) according to any of the preceding claims, wherein the  
base member (3) has near the connector end part (9) a first connector  
member (13) which cooperates with a second connector member (7)  
attached to the first end (5) of the strap (12).  
30

5. Chest support (1) belt according to any of the preceding claims, the base member (3) comprising near the roller member (35) a pivoting lever (42) which can be pivoted with a clamping surface (44) into clamping engagement with the roller member (35) and/or with the guide surface (33)..

5

6. Chest support (1) belt according to any of the preceding claims, wherein the base member (3) has a curved surface (33) with the first and second ends (50,51) defining a support surface (53) and with a middle section (52) spaced at a distance from the support surface.

10

*Fig 1*

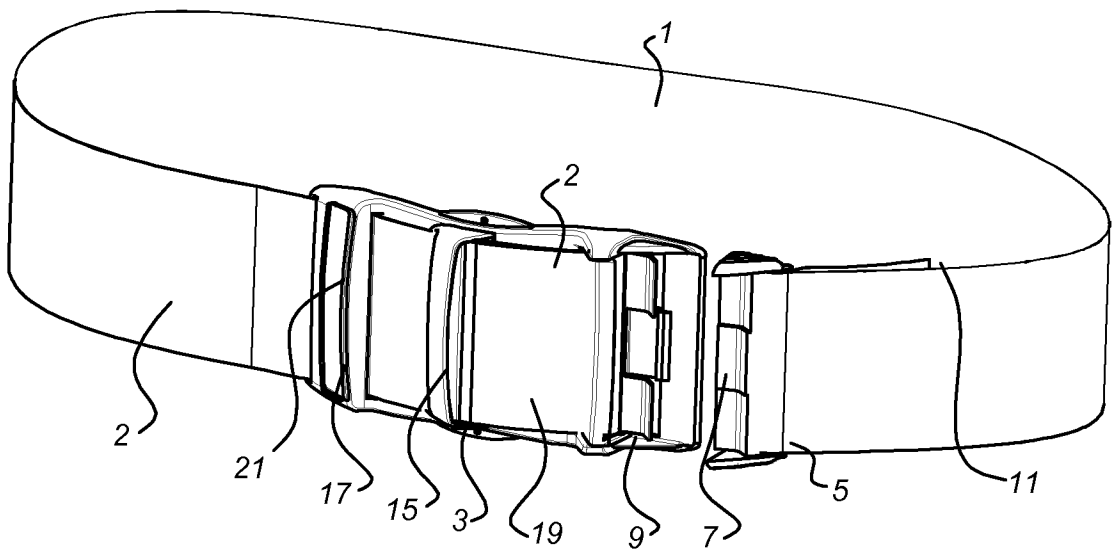

*Fig 3*

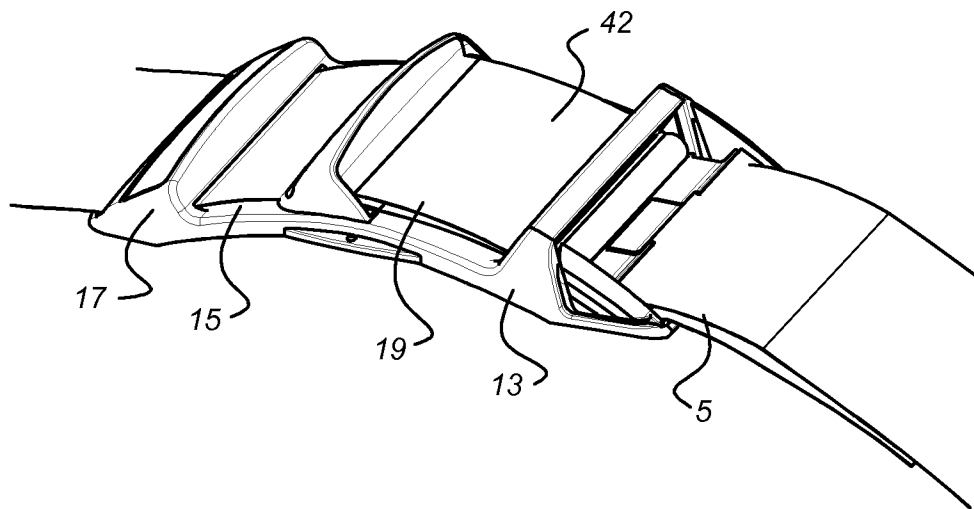

Fig 2

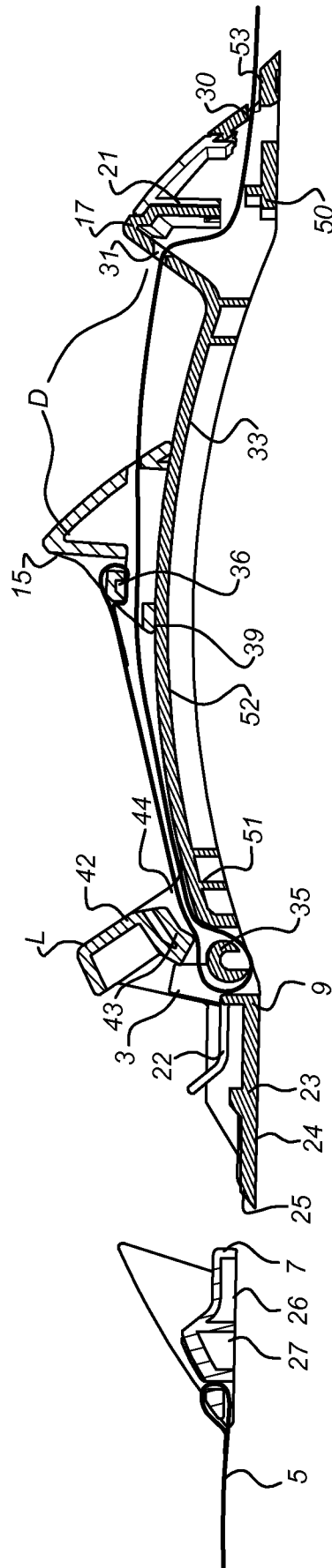

Fig 4

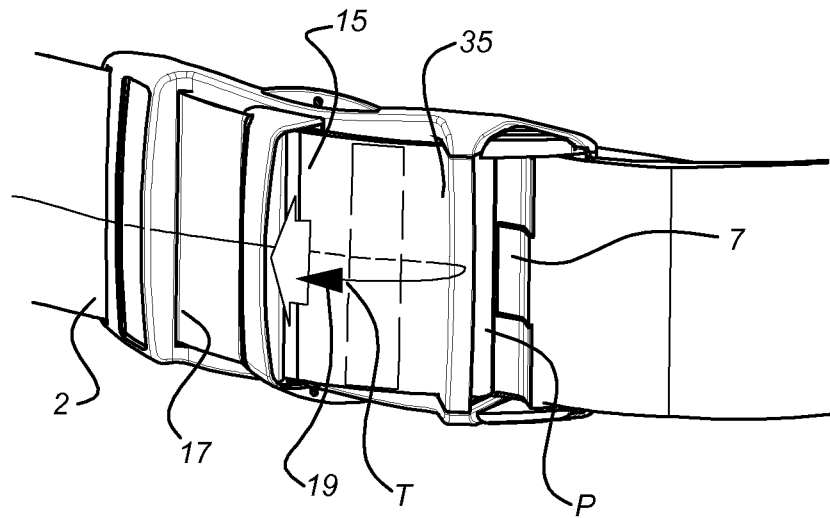
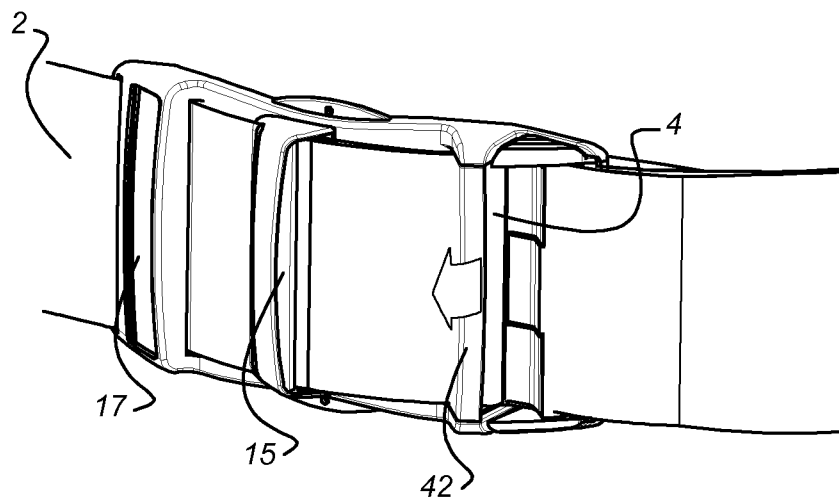

Fig 5



**INTERNATIONAL SEARCH REPORT**

International application No  
PCT/NL2010/050002

**A. CLASSIFICATION OF SUBJECT MATTER**  
INV. A61F5/00  
ADD.

According to International Patent Classification (IPC) or to both national classification and IPC

**B. FIELDS SEARCHED**  
Minimum documentation searched (classification system followed by classification symbols)  
A61F A41F

Documentation searched other than minimum documentation to the extent that such documents are included in the fields searched

Electronic data base consulted during the international search (name of data base and, where practical, search terms used)  
EPO-Internal

**C. DOCUMENTS CONSIDERED TO BE RELEVANT**

Category*	Citation of document, with indication, where appropriate, of the relevant passages	Relevant to claim No.
A	GB 709 388 A (PETER CAMPBELL) 19 May 1954 (1954-05-19) the whole document	1
A	EP 0 260 351 A (WILLIAMS GLENN A JR WILLIAMS SCOTT ALEXANDER [US]) 23 March 1988 (1988-03-23) cited in the application the whole document	1
A	US 2001/034498 A1 (HEYMAN ARNOLD M [US] ET AL) 25 October 2001 (2001-10-25) abstract; figures	1
A	EP 0 368 583 A (SETON HEALTHCARE GROUP PLC [GB]) 16 May 1990 (1990-05-16) abstract	1
	----- -/--	

Further documents are listed in the continuation of Box C.

See patent family annex.

\* Special categories of cited documents :

- "A" document defining the general state of the art which is not considered to be of particular relevance
- "E" earlier document but published on or after the international filing date
- "L" document which may throw doubts on priority claim(s) or which is cited to establish the publication date of another citation or other special reason (as specified)
- "O" document referring to an oral disclosure, use, exhibition or other means
- "P" document published prior to the international filing date but later than the priority date claimed

- "T" later document published after the international filing date or priority date and not in conflict with the application but cited to understand the principle or theory underlying the invention
- "X" document of particular relevance; the claimed invention cannot be considered novel or cannot be considered to involve an inventive step when the document is taken alone
- "Y" document of particular relevance; the claimed invention cannot be considered to involve an inventive step when the document is combined with one or more other such documents, such combination being obvious to a person skilled in the art.
- "&" document member of the same patent family

Date of the actual completion of the international search  
**26 April 2010**

Date of mailing of the international search report  
**10/05/2010**

Name and mailing address of the ISA/  
European Patent Office, P.B. 5818 Patentlaan 2  
NL - 2280 HV Rijswijk  
Tel. (+31-70) 340-2040,  
Fax: (+31-70) 340-3016

Authorized officer  
**Sánchez y Sánchez, J**

INTERNATIONAL SEARCH REPORT

International application No

PCT/NL2010/050002

C(Continuation). DOCUMENTS CONSIDERED TO BE RELEVANT

Category*	Citation of document, with indication, where appropriate, of the relevant passages	Relevant to claim No.
A	WO 2008/041688 A (BUILMATEL CO LTD [JP]; SHIRAI SYOJI [JP]; MUSHU KOUHEI [JP]) 10 April 2008 (2008-04-10) abstract; figures -----	1

# INTERNATIONAL SEARCH REPORT

Information on patent family members

International application No

PCT/NL2010/050002

Patent document cited in search report	Publication date	Patent family member(s)	Publication date
GB 709388	A	19-05-1954	NONE
EP 0260351	A	23-03-1988	DE 3689310 D1 23-12-1993 DE 3689310 T2 10-03-1994 JP 2039481 C 28-03-1996 JP 7075614 B 16-08-1995 JP 63082658 A 13-04-1988 US 4641642 A 10-02-1987
US 2001034498	A1	25-10-2001	NONE
EP 0368583	A	16-05-1990	AU 4437289 A 10-05-1990 GB 2225926 A 20-06-1990
WO 2008041688	A	10-04-2008	CN 101522067 A 02-09-2009 EP 2087804 A1 12-08-2009 JP 4005109 B1 07-11-2007 JP 2008086639 A 17-04-2008 KR 20090060357 A 11-06-2009