

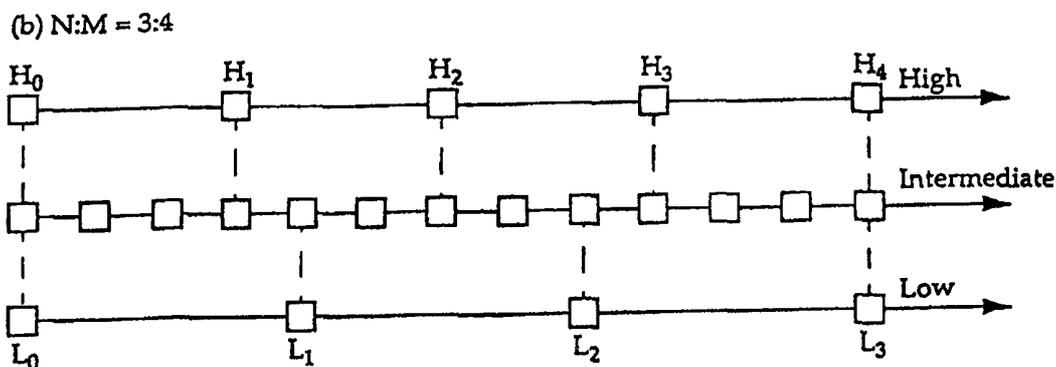

INTERNATIONAL APPLICATION PUBLISHED UNDER THE PATENT COOPERATION TREATY (PCT)

<p>(51) International Patent Classification ⁶ : H03H 17/06</p>	<p>A1</p>	<p>(11) International Publication Number: WO 99/45645 (43) International Publication Date: 10 September 1999 (10.09.99)</p>
<p>(21) International Application Number: PCT/GB99/00682 (22) International Filing Date: 8 March 1999 (08.03.99) (30) Priority Data: 9804936.4 6 March 1998 (06.03.98) GB (71) Applicant (for all designated States except US): BRITISH BROADCASTING CORPORATION [GB/GB]; Broadcasting House, London WC1A 1AA (GB). (72) Inventor; and (75) Inventor/Applicant (for US only): WERNER, Olivier, Hartwig [DE/GB]; Flat 1, Birdhurst Road 14C, South Croydon, Surrey CR2 7EA (GB). (74) Agents: GARRATT, Peter, Douglas et al.; Mathys & Squire, 100 Gray's Inn Road, London WCIX 8AL (GB).</p>		<p>(81) Designated States: US, European patent (AT, BE, CH, CY, DE, DK, ES, FI, FR, GB, GR, IE, IT, LU, MC, NL, PT, SE). Published With international search report.</p>

(54) Title: CASCADING OF UP CONVERSION AND DOWN CONVERSION



(57) Abstract

In digital video, 3:4 up conversion and 4:3 down conversion are transparently cascaded. The up conversion filter is: $S_{up}(n) = \sum S_{input}(k) \cdot g(3n - 4k)$ and the down conversion filter is: $S_{down}(n) = \sum S_{up}(k) \cdot h(4n - 3k)$. The pair of up and down conversion filters are designed so that $\sum h(4n - 3k) \cdot g(3k - 4m)$ is equal to unity if $n = m$ and is otherwise equal to zero.

FOR THE PURPOSES OF INFORMATION ONLY

Codes used to identify States party to the PCT on the front pages of pamphlets publishing international applications under the PCT.

AL	Albania	ES	Spain	LS	Lesotho	SI	Slovenia
AM	Armenia	FI	Finland	LT	Lithuania	SK	Slovakia
AT	Austria	FR	France	LU	Luxembourg	SN	Senegal
AU	Australia	GA	Gabon	LV	Latvia	SZ	Swaziland
AZ	Azerbaijan	GB	United Kingdom	MC	Monaco	TD	Chad
BA	Bosnia and Herzegovina	GE	Georgia	MD	Republic of Moldova	TG	Togo
BB	Barbados	GH	Ghana	MG	Madagascar	TJ	Tajikistan
BE	Belgium	GN	Guinea	MK	The former Yugoslav Republic of Macedonia	TM	Turkmenistan
BF	Burkina Faso	GR	Greece	ML	Mali	TR	Turkey
BG	Bulgaria	HU	Hungary	MN	Mongolia	TT	Trinidad and Tobago
BJ	Benin	IE	Ireland	MR	Mauritania	UA	Ukraine
BR	Brazil	IL	Israel	MW	Malawi	UG	Uganda
BY	Belarus	IS	Iceland	MX	Mexico	US	United States of America
CA	Canada	IT	Italy	NE	Niger	UZ	Uzbekistan
CF	Central African Republic	JP	Japan	NL	Netherlands	VN	Viet Nam
CG	Congo	KE	Kenya	NO	Norway	YU	Yugoslavia
CH	Switzerland	KG	Kyrgyzstan	NZ	New Zealand	ZW	Zimbabwe
CI	Côte d'Ivoire	KP	Democratic People's Republic of Korea	PL	Poland		
CM	Cameroon	KR	Republic of Korea	PT	Portugal		
CN	China	KZ	Kazakstan	RO	Romania		
CU	Cuba	LC	Saint Lucia	RU	Russian Federation		
CZ	Czech Republic	LI	Liechtenstein	SD	Sudan		
DE	Germany	LK	Sri Lanka	SE	Sweden		
DK	Denmark	LR	Liberia	SG	Singapore		
EE	Estonia						

CASCADING OF UP CONVERSION AND DOWN CONVERSION

This invention relates to digital filtering of sampled signals and in an important example to filtering of digital video.

The sampling rate of a digital video has to be changed for converting between different formats. For example, in order to save bandwidth a video signal may be stored and transmitted in a low resolution format but displayed in an up converted high resolution format. Typically, the sampling rate of the low resolution is related to the sampling rate of the high resolution by a ratio 1:M or by a ratio N:M where N and M are integers. Depending on the application, several cascades of up and down conversion filtering can occur. For example in a broadcast chain this is due to repeated editing, preview and storage operations. In order to achieve a perfect reconstruction of those parts of the pictures that have not been changed by editing operations up conversion from the low resolution to the high resolution and subsequent down conversion should result in a transparent cascade. Transparent cascading of N:M up and M:N down conversion filtering imposes additional problems on the filter design when compared with a cascade of up and down conversion filters for ratios 1:M and M:1.

It is an object of one aspect of the present invention to provide an improved digital filtering process capable of transparent up conversion and cascaded down conversion.

Accordingly, the present invention consists in one aspect in a digital filtering process for achieving a transparent cascade on N:M up conversion and subsequent M:N down conversion, where the up and down conversion ratios N:M and M:N respectively are rational numbers and the integers N and M satisfy the condition $1 < N < M$, wherein the up conversion filter operates on a sampled signal s_{input} and is chosen to take the form $s_{up}(n) = \sum s_{input}(k) \cdot g(Nn - Mk)$ and wherein a corresponding down conversion filter operates on the up converted signal s_{up} and is chosen to take the form $s_{down}(n) = \sum s_{up}(k) \cdot h(Mn - Nk)$; the pair (g,h) of up and

- 2 -

down conversion filters being chosen so that $\sum h(Mn - Nk).g(Nk - Mm)$ is equal to unity if $n = m$ and is otherwise equal to zero.

The invention will now be described by way of example with reference to the accompanying drawings, in which :-

5

Figure 1 is a diagram showing the low resolution and high resolution sampling grid for 1:2 up conversion and subsequent 2:1 down conversion;

10

Figure 2 is a diagram showing the low resolution and high resolution sampling grid for 3:4 up conversion and subsequent 4:3 down conversion and showing, additionally, the sampling grid for the intermediate resolution;

15

Figure 3 is a block diagram illustrating the three stages of 3:4 up conversion, that is to say 1:4 up sampling, interpolation filtering, and 3:1 down sampling;

20

Figure 4 is a block diagram illustrating the three stages of 4:3 down conversion, i.e. that is to say 1:3 up sampling, interpolation filtering, 4:1 down sampling; and

Figure 5 is a graph showing the frequency response of 3:4 up conversion filter, bilinear and proposed filter.

For a ratio 1:M and isochronous sampling, the sampling grid of the low resolution signal forms a subset of the sampling grid of the high resolution signal as shown in Figure 1 for the example ratio 1:2. Thus, if the samples of the low resolution signal are copied onto the corresponding positions of the high resolution grid on 1:M up conversion filtering, one subset that contains every M-th sample of the up converted signal coincides with the set of samples of the low resolution signal. An up conversion filter that has this property is called a 1:M Nyquist filter.

30

- 3 -

Therefore, if a 1:M Nyquist filter is followed by a M:1 down sampler one obtains mathematically the identity operator which makes the cascade transparent.

However, this approach does not work for a ratio N:M such as 3:4. The reason is that the sampling grid of the low resolution signal is not an entire subset
 5 of the sampling grid of the high resolution signal. For example in the case of 3:4 up conversion only every third grid position of the low resolution signal coincides with a corresponding grid position of the high resolution signal as shown in Figure 2. Thus, only one third of the samples can be copied from the low to the high resolution. Consequently, only one third of the samples of the low resolution
 10 signal can be recovered simply by sub-sampling the up converted signal. Additional filtering is needed on down conversion to recover the remaining two-thirds.

An example of a filtering process according to the present invention will now be described. This will for illustration concentrate on the example ratios 3:4 on up
 15 conversion and 4:3 on down conversion.

First, some principles of up and down conversion filtering are briefly reviewed. The sampling grids of the low and the high resolution are shown in Figure 2 for 3:4 up conversion and subsequent 4:3 down conversion. Additionally, Figure 2 shows the intermediate sampling grid on which all filter operations are
 20 performed. It is assumed throughout that all filter operations are linear and shift invariant. Thus, each filter can be described by its impulse response. Let g denote the impulse response of the 3:4 up conversion filter. The 3:4 up conversion process can be considered in three stages, see Figure 3.

In the first stage the low resolution signal s is up sampled by the factor 1:4
 25 resulting in the signal t which is defined on the intermediate sampling grid as follows,

$$t(n) = \begin{cases} s(k) & \text{if } n = 4k \\ 0 & \text{otherwise} \end{cases} \quad (1)$$

- 4 -

In the second stage the signal t is interpolated into the signal u ,

$$u(n) = \sum_k t(k) \cdot g(n-k) \quad (2)$$

5 In the third stage the interpolated signal u is down sampled by the factor 3:1, resulting in the up converted signal

$$s_{up}(n) = u(3n) \quad (3)$$

10 Equations (1) to (3) define the functional relationship between the low resolution signal s and the up converted signal s_{up} ,

$$s_{up}(n) = \sum_k s(k) \cdot g(3n-4k) \quad (4)$$

15 As every third position of the low resolution sampling grid coincides with a position of the high resolution sampling grid, the samples of these positions can be copied on 3:4 up conversion,

$$s_{up}(4n) = s(3n) \quad (5)$$

20 One can derive equation (5) from equation (4) if the filter g fulfils the Nyquist condition for 1:4 up conversion,

$$g(4n) = \begin{cases} 1 & \text{if } n = 0 \\ 0 & \text{otherwise} \end{cases} \quad (6)$$

In this description a 3:4 up conversion filter g that fulfils equation (6) is
25 called a 3:4 Nyquist filter. Correspondingly, equation (5) is called the 3:4 Nyquist condition.

- 5 -

Similar to 3:4 up conversion, the 4:3 down conversion process can be considered in three stages, see Figure 4. The relationship between the up converted signal s_{up} , and the down converted signal s_{down} becomes

$$5 \quad s_{down}(n) = \sum_k s_{up}(k) \cdot h(4n - 3k) \quad (7)$$

where h denotes the impulse response of the 4:3 down conversion filter.

Similar to equation (5), the Nyquist condition for 4:3 down conversion can be specified,

$$10 \quad s_{down}(3n) = s_{up}(4n) \quad (8)$$

One can derive equation (8) from equation (7) if the filter h fulfils the Nyquist condition for 1:3 up conversion,

$$15 \quad h(3n) = \begin{cases} 1 & \text{if } n = 0 \\ 0 & \text{otherwise} \end{cases} \quad (9)$$

In this description a 4:3 down conversion filter h that fulfils equation (9) is called a 4:3 Nyquist filter.

One concludes from equations (5) and (8) that the cascade of a 3:4
20 Nyquist filter which is followed by a 4:3 Nyquist filter gives a perfect reconstruction for every third sample of the low resolution signal, i.e.

$$s_{down}(3n) = s(3n) \quad (10)$$

25 However, in order to recover the remaining two-thirds, resulting in

$$s_{down}(n) = s(n) \quad (11)$$

the pair (g, h) of up and down conversion filters has to fulfil the condition:

$$\sum_k h(4n-3k) \cdot g(3k-4m) = \begin{cases} 1 & \text{if } n = m \\ 0 & \text{otherwise} \end{cases} \quad (12)$$

5

Equation (12) is the condition for transparent cascading that can be derived straightforwardly from equations (4) and (7). It shows that the filter coefficients of g and h cannot be chosen independently. For given coefficients of g equation (12) becomes a linear equation system for the coefficients of h and vice versa.

10

From equation (12) one can derive the corollary, that if equation (12) is fulfilled by the pair of up and down conversion filters (g, h) and, additionally, the impulse response of g is symmetric, i.e. $g(n) = g(-n)$ then:

15

i) equation (12) is also fulfilled by the pair of filters (g, h_-) with $h_-(n) = h(-n)$

20

ii) equation (12) is also fulfilled by the pair of filters (g, h_{\sim}) with $h_{\sim} = (1-\lambda) \cdot h + \lambda \cdot h_-$ and $-\infty \leq \lambda \leq \infty$, in particular the impulse response of $h_{\sim} = (h+h_-)/2$ is symmetric.

25

The up converted signal s_{up} should give a good picture quality on displaying. Therefore, firstly the coefficients of the up conversion filter g can be chosen to fulfil this requirement and then a corresponding down conversion filter h can be designed to comply with equation (12), resulting in a transparent cascade.

The length of the impulse response is an obvious limitation in practical applications. Bilinear interpolation results in a short impulse response. The coefficients of the symmetric impulse response g_{bil} are shown in Table 1. However, bilinear interpolation filtering does not result in a sophisticated low pass

characteristic. Therefore, Table 1 shows also the symmetric impulse response of the filter g_{def} that is proposed for 3:4 up conversion. The filter coefficients are derived from a windowed $\sin(x)/x$ waveform to give a better low pass characteristic than the bilinear interpolation filter. The frequency responses of g_{bil} and g_{def} are compared in Figure 5. The improved low pass characteristic comes at a price as 15 taps are needed for g_{def} but only 7 taps for g_{bil} . The coefficients of g_{def} are rounded to six decimal digits as shown in Table 1. It is not difficult to verify that both up conversion filters of Table 1 are 3:4 Nyquist filters.

For the given 3:4 Nyquist filters g_{bil} and g_{def} corresponding 4:3 Nyquist filters $h_{undo-bil}$ and $h_{undo-def}$ respectively, are designed in order to comply with equation (12). The filter coefficients are also listed in Table 1. Similar to g_{def} the coefficients of $h_{undo-def}$ are rounded to six decimal digits. In contrast to the up conversion filters, the corresponding down conversion filters of Table 1 do not have a symmetric impulse response. Again, the impulse response length of the proposed filter is larger, i.e. 29 taps are needed for $h_{undo-def}$ but only 9 taps for $h_{undo-bil}$.

It follows from the corollary to equation (12) that the non-symmetric impulse responses of the down conversion filters of Table 1 can be converted into symmetric impulse responses by mirroring. However, this would increase the number of filter taps.

It will be understood that this invention has been described by way of example only and that a wide variety of modifications are possible without departing from the scope of the invention.

It has already been explained that the ratios 3:4 and 4:3 have been chosen by way of illustration only. The invention is more broadly applicable to cascaded N:M up conversion and subsequent M:N down conversion, where the up and down conversion ratios N:M and M:N respectively are rational numbers and the integers N and M satisfy the condition $1 < N < M$. In the field of video, the invention is applicable not only to horizontal processing, but also to vertical processing and temporal processing. If processing is required in two or more of these dimensions, it will generally be possible to identify pairs of one dimensional filters in accordance

with the present invention and then to cascade those filters to achieve the desired two or three dimensional processing.

n	$g_{bil}(n)$	n	$h_{undo-bil}(n)$	n	$g_{def}(n)$	n	$h_{undo-def}(n)$
0	1	-8	1/3	0	1	-8	0.003449
-1, 1	3/4	-7	0	-1, 1	0.854892	-7	0
-2, 2	1/2	-6	0	-2, 2	0.530332	-6	0
-3, 3	1/4	-5	-4/3	-3, 3	0.204804	-5	0
otherwise	0	-4	-1/3	-4, 4	0	-4	0.053745
		-3	0	-5, 5	-0.054860	-3	0
		-2	2	-6, 6	-0.030332	-2	0.113710
		-1	4/3	-7, 7	-0.004832	-1	0
		0	1	otherwise	0	0	1
		otherwise	0			1	1.099232
						2	1.771901
						3	0
						4	-0.222855
						5	-1.099232
						6	0
						7	0.005838
						8	0.280050
						9	0
						10	0.000604
						11	-0.005838
						12	0
						13	0
						14	-0.000604
						15	0
						16	0.000018
						17	0
						18	0
						19	0
						20	-0.000018
						otherwise	0

Table 1: Nyquist filter for 3:4 up conversion, bilinear (bil) and proposed filter (def) and Nyquist filter for subsequent 4:3 down conversion, undo bilinear (undo-bil), undo proposed (undo-def) 3:4 up conversion

CLAIMS

1. A filtering process for achieving a transparent cascade on N:M up conversion and subsequent M:N down conversion, where the up and down conversion ratios N:M and M:N respectively are rational numbers and the integers N and M satisfy the condition $1 < N < M$, wherein the up conversion filter operates on a sampled signal s_{input} and is chosen to take the form $s_{up}(n) = \sum s_{input}(k) \cdot g(Nn - Mk)$ and wherein a corresponding down conversion filter operates on the up converted signal s_{up} and is chosen to take the form $s_{down}(n) = \sum s_{up}(k) \cdot h(Mn - Nk)$; the pair (g,h) of up and down conversion filters being chosen so that $\sum h(Mn - Nk) \cdot g(Nk - Mm)$ is equal to unity if $n = m$ and is otherwise equal to zero.

2. A process according to Claim 1, wherein the up conversion filter is a N:M Nyquist filter with a symmetric impulse response and the down conversion filter is a M:N Nyquist filter with a non-symmetric impulse response.

3. A process according to Claim 1, wherein the up conversion filter is a N:M Nyquist filter with a symmetric impulse response and the down conversion filter is a M:N Nyquist filter with a symmetric impulse response.

4. A pair of respectively N:M up conversion and subsequent M:N down conversion filters, where the up and down conversion ratios N:M and M:N respectively are rational numbers and the integers N and M satisfy the condition $1 < N < M$, wherein the up conversion filter is adapted to operate on a sampled signal s_{input} and is chosen to take the form $s_{up}(n) = \sum s_{input}(k) \cdot g(Nn - Mk)$ and wherein the down conversion filter is adapted to operate on the up converted signal s_{up} and is chosen to take the form $s_{down}(n) = \sum s_{up}(k) \cdot h(Mn - Nk)$; the pair (g,h) of up and down conversion filters being chosen so that $\sum h(Mn - Nk) \cdot g(Nk - Mm)$ is equal to unity if $n = m$ and is otherwise equal to zero.
5. A M:N down conversion filter adapted to operate on the output $s_{up}(n)$ of a N:M up conversion digital filter of the form $s_{up}(n) = \sum s_{input}(k) \cdot g(Nn - Mk)$, where the up and down conversion ratios N:M and M:N respectively are rational numbers and the integers N and M satisfy the condition $1 < N < M$, wherein the down conversion filter is chosen to take the form $s_{down}(n) = \sum s_{up}(k) \cdot h(Mn - Nk)$; where $\sum h(Mn - Nk) \cdot g(Nk - Mm)$ is equal to unity if $n = m$ and is otherwise equal to zero.

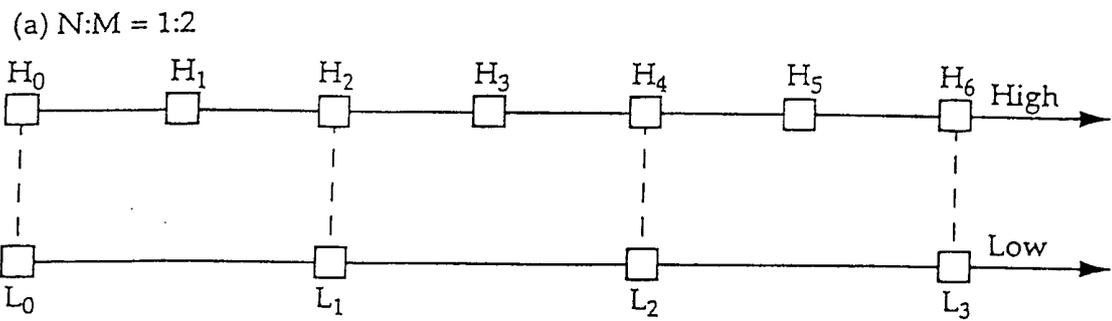

FIGURE 1

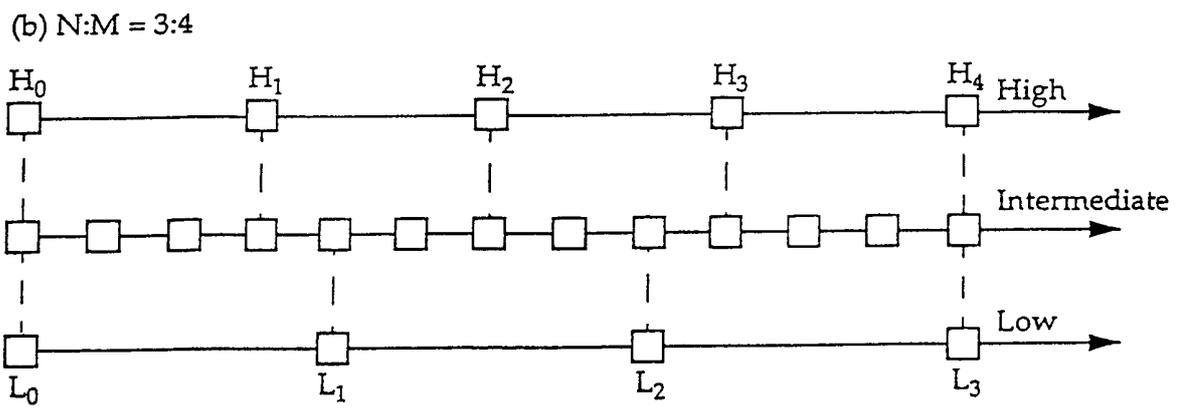

FIGURE 2

(a) 3:4 up conversion

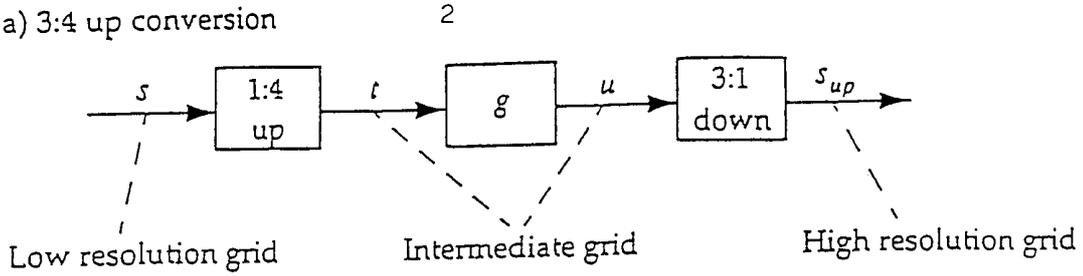

FIGURE 3

(b) 4:3 down conversion

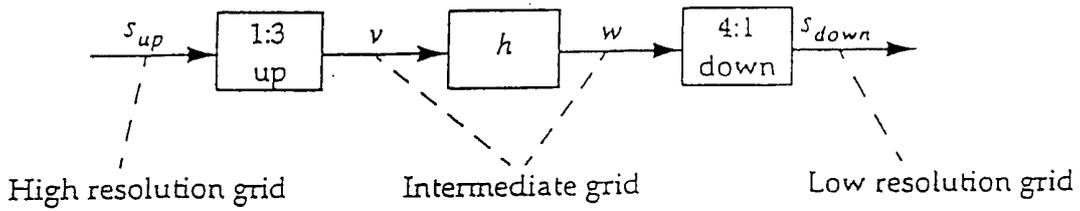

FIGURE 4

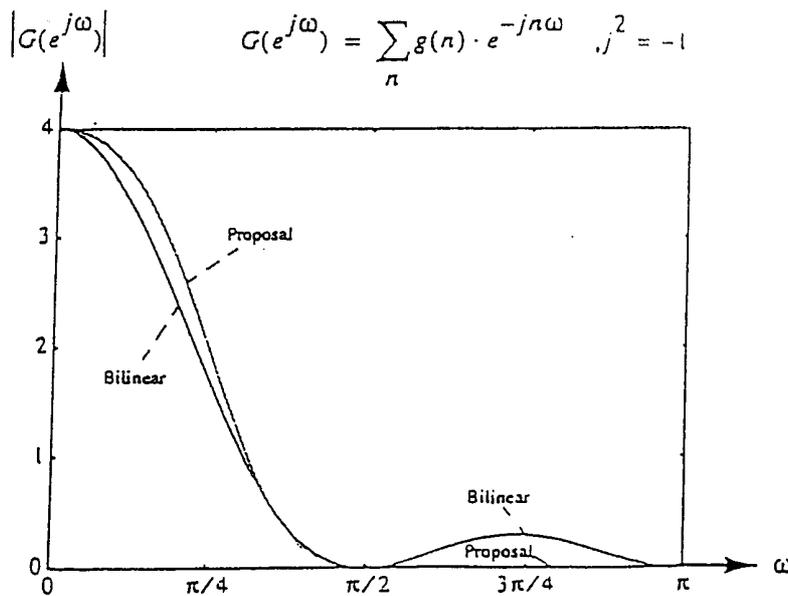

FIGURE 5

INTERNATIONAL SEARCH REPORT

International Application No
PCT/GB 99/00682

A. CLASSIFICATION OF SUBJECT MATTER IPC 6 H03H17/06				
According to International Patent Classification (IPC) or to both national classification and IPC				
B. FIELDS SEARCHED				
Minimum documentation searched (classification system followed by classification symbols) IPC 6 H03H				
Documentation searched other than minimum documentation to the extent that such documents are included in the fields searched				
Electronic data base consulted during the international search (name of data base and, where practical, search terms used)				
C. DOCUMENTS CONSIDERED TO BE RELEVANT				
Category °	Citation of document, with indication, where appropriate, of the relevant passages	Relevant to claim No.		
A	BOCK A M: "DESIGN CRITERIA FOR VIDEO SAMPLING RATE CONVERSION FILTERS" ELECTRONICS LETTERS, vol. 26, no. 16, 2 August 1990, page 1259/1260 XP000108280 see the whole document -----	1		
<input type="checkbox"/> Further documents are listed in the continuation of box C.				
<input type="checkbox"/> Patent family members are listed in annex.				
° Special categories of cited documents :				
<table style="width: 100%; border: none;"> <tr> <td style="width: 50%; border: none; vertical-align: top;"> "A" document defining the general state of the art which is not considered to be of particular relevance "E" earlier document but published on or after the international filing date "L" document which may throw doubts on priority claim(s) or which is cited to establish the publication date of another citation or other special reason (as specified) "O" document referring to an oral disclosure, use, exhibition or other means "P" document published prior to the international filing date but later than the priority date claimed </td> <td style="width: 50%; border: none; vertical-align: top;"> "T" later document published after the international filing date or priority date and not in conflict with the application but cited to understand the principle or theory underlying the invention "X" document of particular relevance; the claimed invention cannot be considered novel or cannot be considered to involve an inventive step when the document is taken alone "Y" document of particular relevance; the claimed invention cannot be considered to involve an inventive step when the document is combined with one or more other such documents, such combination being obvious to a person skilled in the art. "&" document member of the same patent family </td> </tr> </table>			"A" document defining the general state of the art which is not considered to be of particular relevance "E" earlier document but published on or after the international filing date "L" document which may throw doubts on priority claim(s) or which is cited to establish the publication date of another citation or other special reason (as specified) "O" document referring to an oral disclosure, use, exhibition or other means "P" document published prior to the international filing date but later than the priority date claimed	"T" later document published after the international filing date or priority date and not in conflict with the application but cited to understand the principle or theory underlying the invention "X" document of particular relevance; the claimed invention cannot be considered novel or cannot be considered to involve an inventive step when the document is taken alone "Y" document of particular relevance; the claimed invention cannot be considered to involve an inventive step when the document is combined with one or more other such documents, such combination being obvious to a person skilled in the art. "&" document member of the same patent family
"A" document defining the general state of the art which is not considered to be of particular relevance "E" earlier document but published on or after the international filing date "L" document which may throw doubts on priority claim(s) or which is cited to establish the publication date of another citation or other special reason (as specified) "O" document referring to an oral disclosure, use, exhibition or other means "P" document published prior to the international filing date but later than the priority date claimed	"T" later document published after the international filing date or priority date and not in conflict with the application but cited to understand the principle or theory underlying the invention "X" document of particular relevance; the claimed invention cannot be considered novel or cannot be considered to involve an inventive step when the document is taken alone "Y" document of particular relevance; the claimed invention cannot be considered to involve an inventive step when the document is combined with one or more other such documents, such combination being obvious to a person skilled in the art. "&" document member of the same patent family			
Date of the actual completion of the international search <div style="text-align: center; font-size: 1.2em;">7 June 1999</div>		Date of mailing of the international search report <div style="text-align: center; font-size: 1.2em;">11/06/1999</div>		
Name and mailing address of the ISA European Patent Office, P.B. 5818 Patentlaan 2 NL - 2280 HV Rijswijk Tel. (+31-70) 340-2040, Tx. 31 651 epo nl, Fax: (+31-70) 340-3016		Authorized officer <div style="text-align: center; font-size: 1.2em;">Coppieters, C</div>		