

(No Model.)

2 Sheets—Sheet 1.

T. F. MOORE.  
TRESTLE.

No. 524,807.

Patented Aug. 21, 1894.

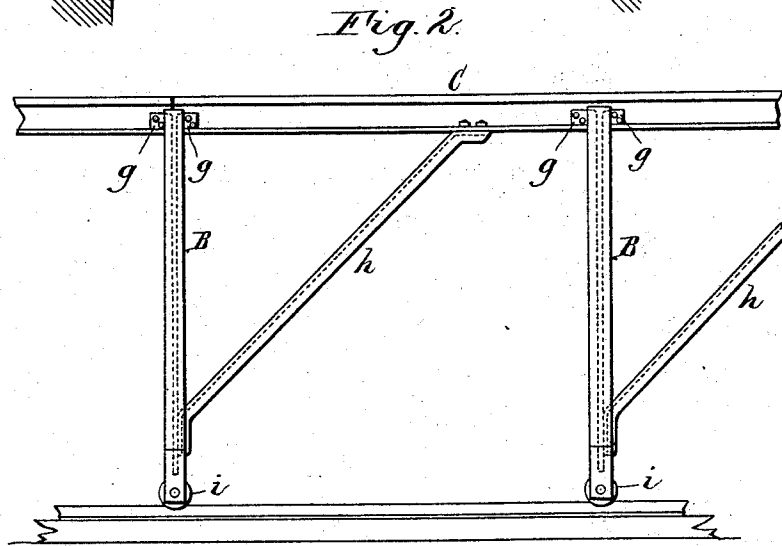
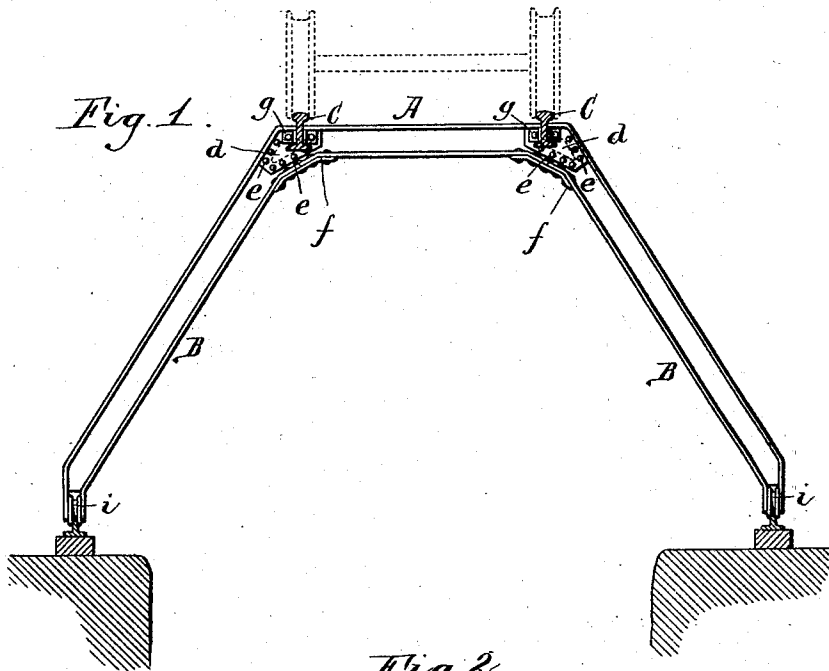

Witnesses:

*Emil Neuhart.*  
*Theo. L. Popp.*

*Thomas F. Moore* Inventor.

*By Wilhelm Dornier.*

Attorneys.

(No Model.)

2 Sheets—Sheet 2.

T. F. MOORE.  
TRESTLE.

No. 524,807.

Patented Aug. 21, 1894.

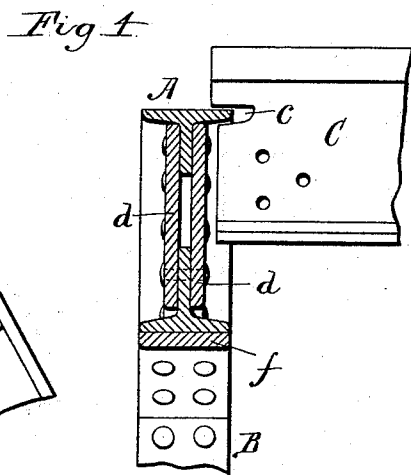
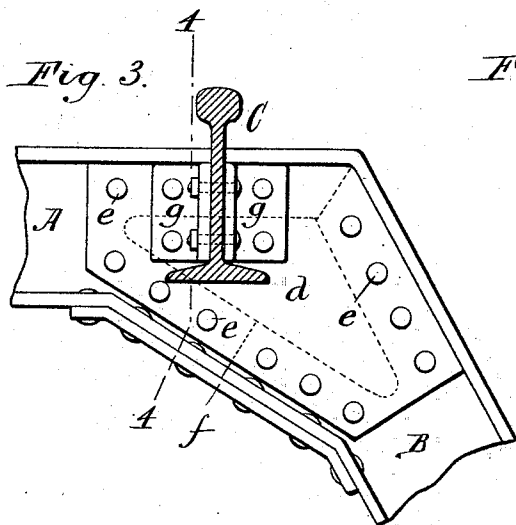

*Fig. 5.*

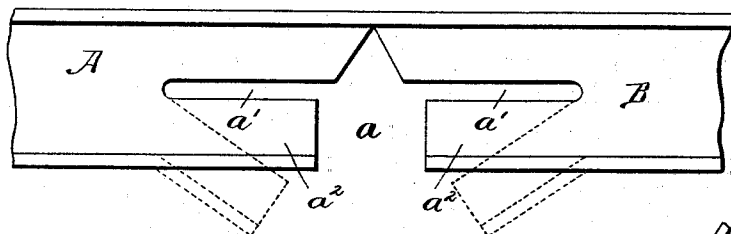

*Fig. 6.*

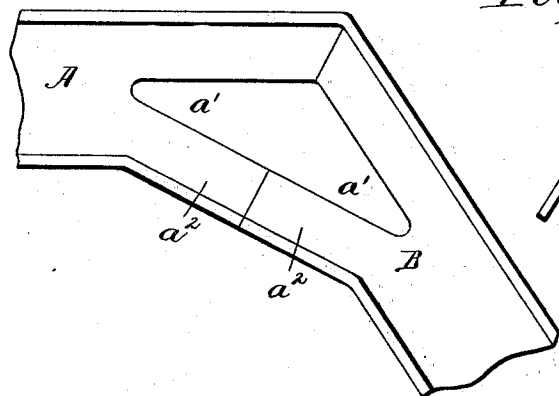

*Fig. 7.*

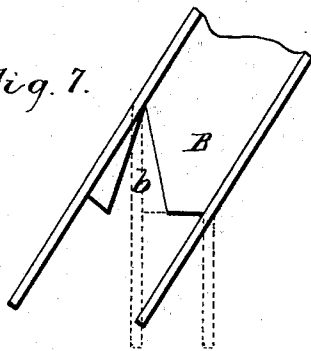

Witnesses:

*Emil Neubart.*  
*Theo. L. Popp.*

Inventor

*Thomas F. Moore*

*By Wilhelm Popp*

Attorneys

# UNITED STATES PATENT OFFICE.

THOMAS F. MOORE, OF BUFFALO, NEW YORK.

## TRESTLE.

SPECIFICATION forming part of Letters Patent No. 524,807, dated August 21, 1894.

Application filed April 30, 1894. Serial No. 509,426. (No model.)

*To all whom it may concern:*

Be it known that I, THOMAS F. MOORE, a citizen of the United States, residing at Buffalo, in the county of Erie and State of New York, have invented a new and useful Improvement in Trestles, of which the following is a specification.

This invention relates to a metallic trestle designed more especially for use in connection with the bucket hoisting and conveying devices which are employed in digging sewer trenches, the trestle spanning the trench and having tracks upon which the bucket-conveying car runs.

The object of my invention is to produce a trestle of simple construction, which shall be light and at the same time possess sufficient strength to span a comparatively wide trench without requiring cross ties or similar obstructions which interfere with the free operation of the hoisting and conveying mechanism.

In the accompanying drawings consisting of two sheets:—Figure 1 is a transverse section of my improved trestle. Fig. 2 is a fragmentary side elevation thereof. Fig. 3 is an enlarged side elevation of one of the joints whereby the cross beams of the trestle are connected with their divergent supporting legs. Fig. 4 is a cross section in line 4—4, Fig. 3, with one of the recessed stringers shown adjacent to the cross beam, preparatory to moving the same into place. Fig. 5 is a fragmentary side elevation of one of the cross beams, showing the form thereof after being recessed and before being bent. Fig. 6 is a similar view of said beam after it is bent and before the connecting plates are applied thereto. Fig. 7 is an elevation of the lower portion of one of the divergent legs, showing the form thereof after being recessed and before its flanges are bent to form the wheel supporting fork.

Like letters of reference refer to like parts in the several figures.

The trestle consists essentially of cross beams A arranged at suitable intervals and supported at their ends by inclined or divergent legs B, and longitudinal beams or stringers C, connecting the cross beams.

Each of the cross beams and its two supporting legs are preferably bent from a con-

tinuous wrought iron I-beam which is provided with recesses *a* at the points where it is subsequently bent. These recesses extend 55 from the under side of the beam to the upper flange, and their upper portions are preferably of inverted V-shape, and their lower portions rectangular, as shown in Fig. 5. The web portions of the beam, on opposite sides 60 of these recesses, are formed with longitudinal slots *a'* which extend inward a short distance from the edges of the recesses. After the straight I-beam has been thus recessed and slotted, and before bending the 65 same, the portions *a*<sup>2</sup> of the beam, below the longitudinal slots, are bent downward, as shown by dotted lines in Fig. 5, so that upon bending the beam at the recesses, until the square ends of the portions *a*<sup>2</sup> abut, such portions are brought in line forming an inclined 70 brace on the inner side of the joint, as shown in Fig. 6, whereby the joint is stiffened and increased in width. After the beam has been so bent, the split portions thereof are 75 connected by plates *d d*, which extend across the joints on opposite sides of the web of the beam and are secured thereto by rivets or bolts *e* passing through the web and both connecting plates, as shown in Fig. 4. 80

A reinforcing plate *f* preferably extends across each joint on the inner side of the beam, the plates being riveted or bolted to the inner flange of the beam. As the outer flange of the I-beam is continuous from end 85 to end thereof, the connection at the bends of the beam is rendered both strong and slightly.

The stringers C preferably consist of "deck-beams," or beams having substantially the cross section of ordinary rail road rails. 90 These rails are secured at their ends to the cross beams A by angle plates *g* or other suitable fastenings and are formed in the ends of their webs with recesses or notches *c* which receive the upper flanges of the cross beams, 95 as shown in Fig. 4., and permit the ends of the rails to be fitted closely against the cross beams. The rails while forming the stringers of the trestle, also serve as tracks for the 100 usual bucket conveying car, and for this purpose the heads of these rails are arranged to project a short distance above the cross beams, as shown in the drawings so that the wheels of the conveying car clear the cross beams.

By this construction, the use of separate or additional tracks for the conveying car is dispensed with, and the trestle is rendered lighter, without reducing its strength or rigidity.

5 *h* represents inclined braces which connect the legs of the cross beams with the under sides of the stringers.

10 *i* represents the usual wheels which are journaled at the lower ends of the divergent supporting legs B and which run upon the surface tracks extending along opposite sides of the trench, so that the trestle may be shifted as the work progresses.

15 The web is cut away at the lower end of each leg B, and the portion of the flanges which project below the web are bent into a vertical position, parallel with each other, as shown by dotted lines in Fig. 7, to form a supporting fork for the journal of the wheel *z*. To enable these flanges to be bent into a vertical position, the adjacent portion of the web of each leg is recessed or cut out in the form of a V, as shown at *b* in Fig. 7. After 25 bending the projecting flanges into position, the abutting edges of the recess *b* are welded together making the web practically solid at this point. The flanges are finally perforated to receive the journal of the supporting 30 wheel. This integral construction of the wheel forks is very simple, as it involves no bolts, rivets or other parts separate from the legs B.

I claim as my invention—

35 1. A trestle supporting member consisting of a horizontal cross beam and depending legs bent from a continuous I-beam, the web and lower flange of the I-beam being divided at the bends or angles where the cross beam and 40 depending legs meet, whereby the upper or outer flange of the I-beam remains intact from end to end of the latter, substantially as set forth.

45 2. A trestle supporting member consisting of a horizontal cross beam and depending legs,

the bends or angles where the said members meet being formed with longitudinal slots arranged partly in the horizontal beam and partly in the depending legs and the portions of the beam and legs on the lower sides of said slots being bent downward in line with each other, forming inclined braces on the under sides of said angles or bends, substantially as set forth. 50

3. A trestle supporting member consisting of a horizontal cross beam and depending legs, the bends or angles where the said members meet being formed with longitudinal slots arranged partly in the horizontal beam and partly in the depending legs and the portions 60 of the beam and legs on the lower sides of said slots being bent downward in line with each other, forming inclined braces on the undersides of said angles or bends, and connecting plates secured to opposite sides of the beams and legs at said bends or angles, substantially as set forth. 65

4. In a trestle, the combination with transverse I-beams having supporting legs, of combined tracks and stringers consisting of rails 70 secured to said I-beams having their heads projecting above the beams and provided in their ends with recesses which receive the upper flanges of said beams, substantially as set forth. 75

5. A trestle support formed from an I-beam having the web cut away at its lower end, the portions of the flanges which project below the web being bent into a vertical position and provided with perforations adapted to receive the axle of a wheel arranged between the perforated flanges, substantially as set forth. 80

Witness my hand this 18th day of April, 1894.

THOMAS F. MOORE.

Witnesses:

CARL F. GEYER,  
JNO. J. BONNER.