

No. 688,912.

Patented Dec. 17, 1901.

W. WATTS.
PORTABLE GRAIN ELEVATOR.

(Application filed June 17, 1901.)

(No Model.)

5 Sheets—Sheet 1.

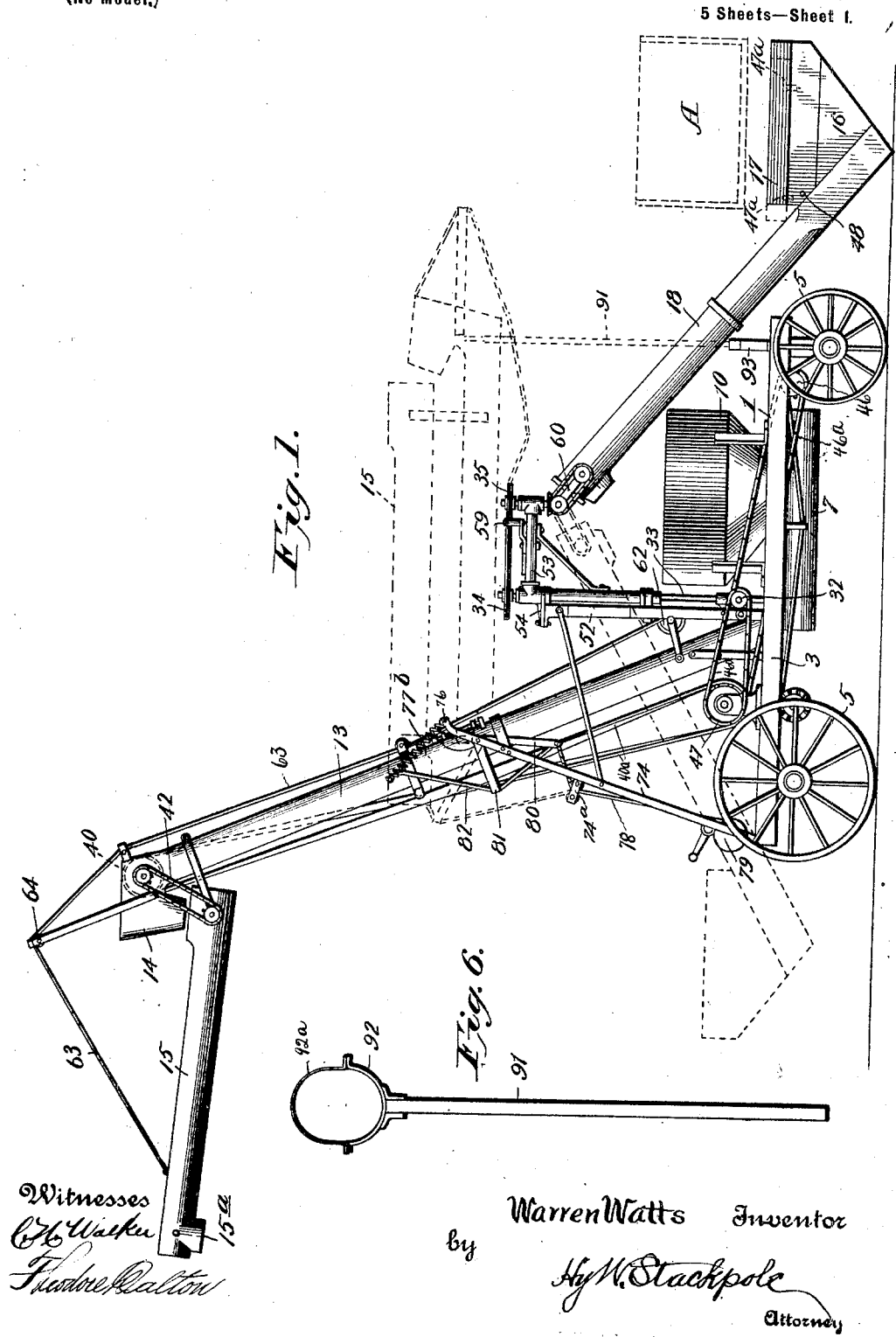

Fig. 1.

Fig. 6.

Witnesses
C. H. Walker
Theodore Dalton

Warren Watts Inventor
by H. N. Stackpole
Attorney

No. 688,912.

Patented Dec. 17, 1901.

W. WATTS.
PORTABLE GRAIN ELEVATOR.

(Application filed June 17, 1901.)

(No Model.)

5 Sheets—Sheet 2.

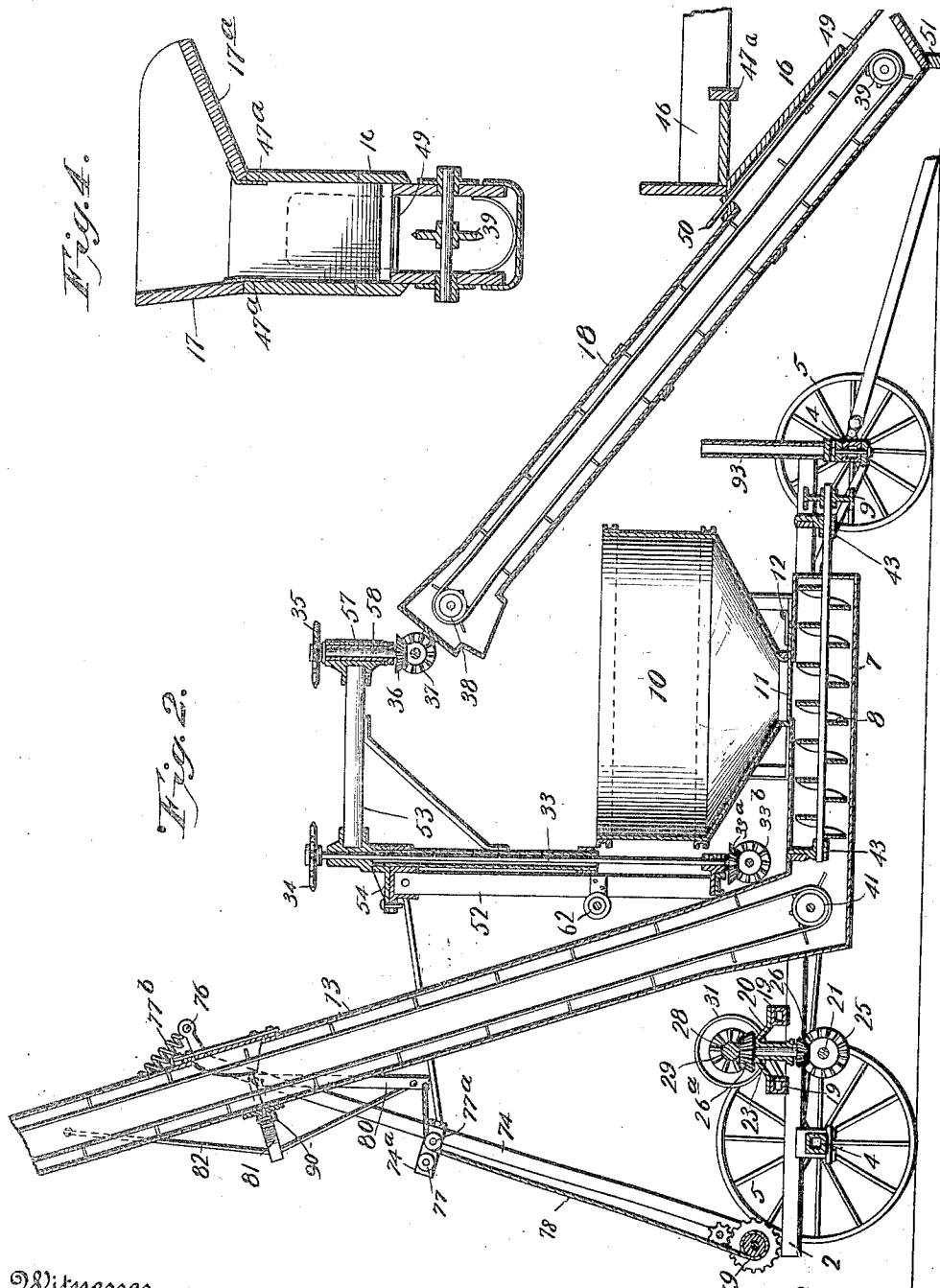

Witnesses
E. Walker
Frederic Dalton

Inventor
Warren Watts
by *Hy M. Stackpole*
Attorney.

No. 688,912.

Patented Dec. 17, 1901.

W. WATTS.
PORTABLE GRAIN ELEVATOR.

(Application filed June 17, 1901.)

(No Model.)

5 Sheets—Sheet 3.

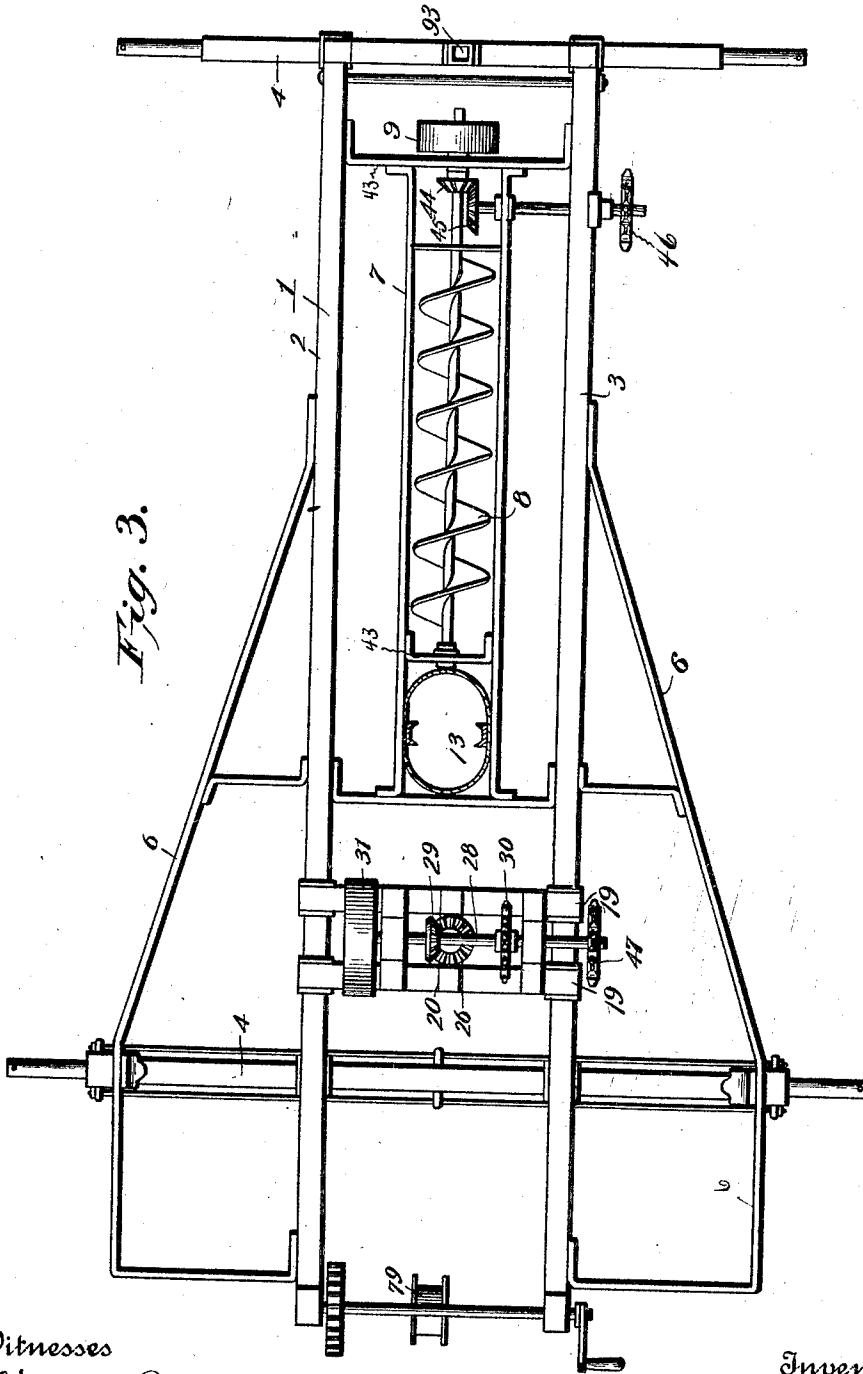

Fig. 3.

Witnesses

C. H. Walker
Richard Patton

Inventor

Warren Watts

by *Hy M. Stackpole*
Attorney

No. 688,912.

Patented Dec. 17, 1901.

W. WATTS.
PORTABLE GRAIN ELEVATOR.

(Application filed June 17, 1901.)

(No Model.)

5 Sheets—Sheet 4.

Fig. 5.

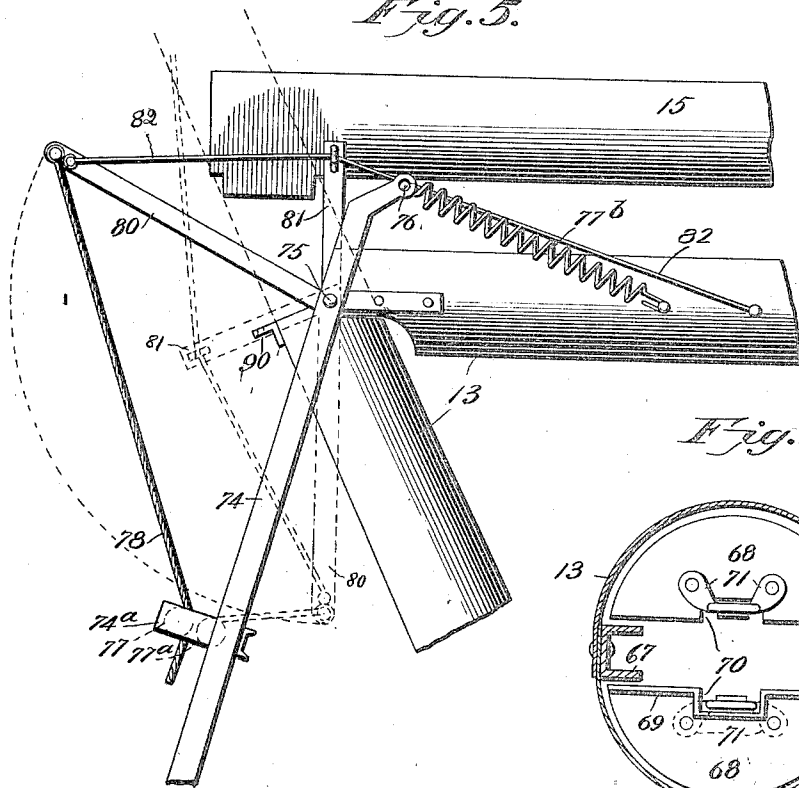

Fig. 7.

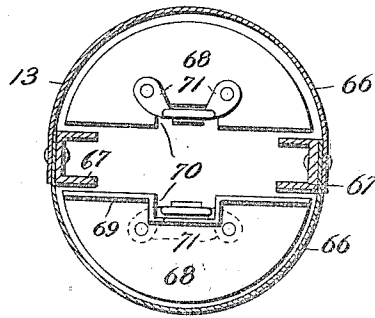

Fig. 8.

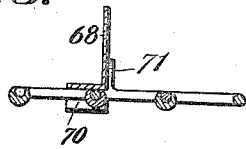

Fig. 11.

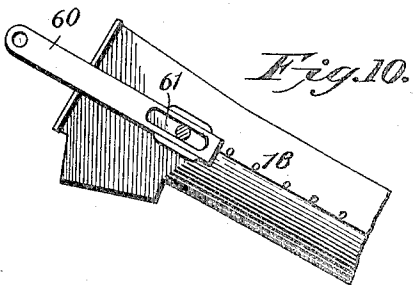
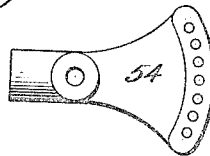
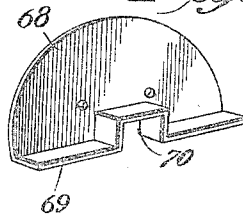

Fig. 10.

Fig. 9.



Witnesses
C. H. Walker
Theodore Dalton

Warren Watts Inventor
 By *H. W. Stackpole*
 Attorney

No. 688,912.

Patented Dec. 17, 1901.

W. WATTS.
PORTABLE GRAIN ELEVATOR.

(Application filed June 17, 1901.)

(No Model.)

5 Sheets—Sheet 5

Fig. 13.

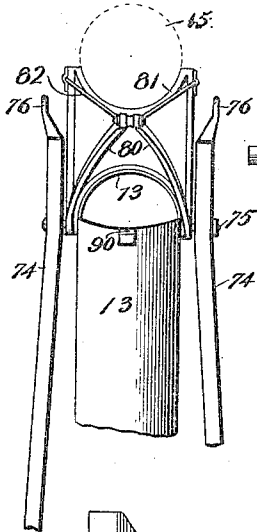

Fig. 14.

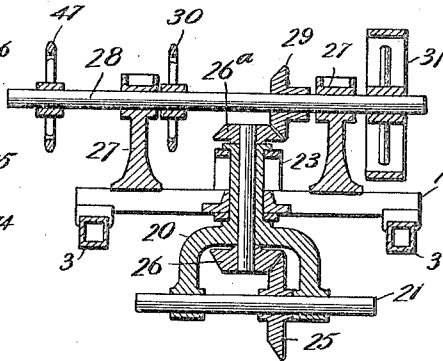

Fig. 15.

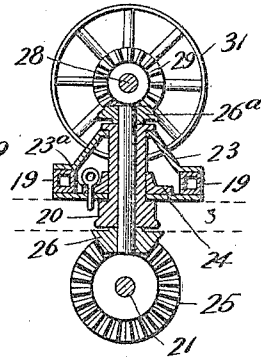

Fig. 16.

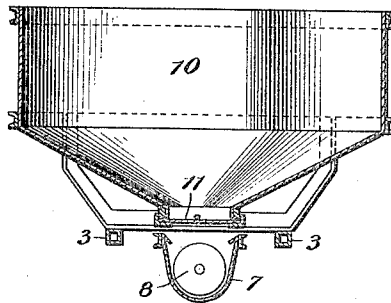
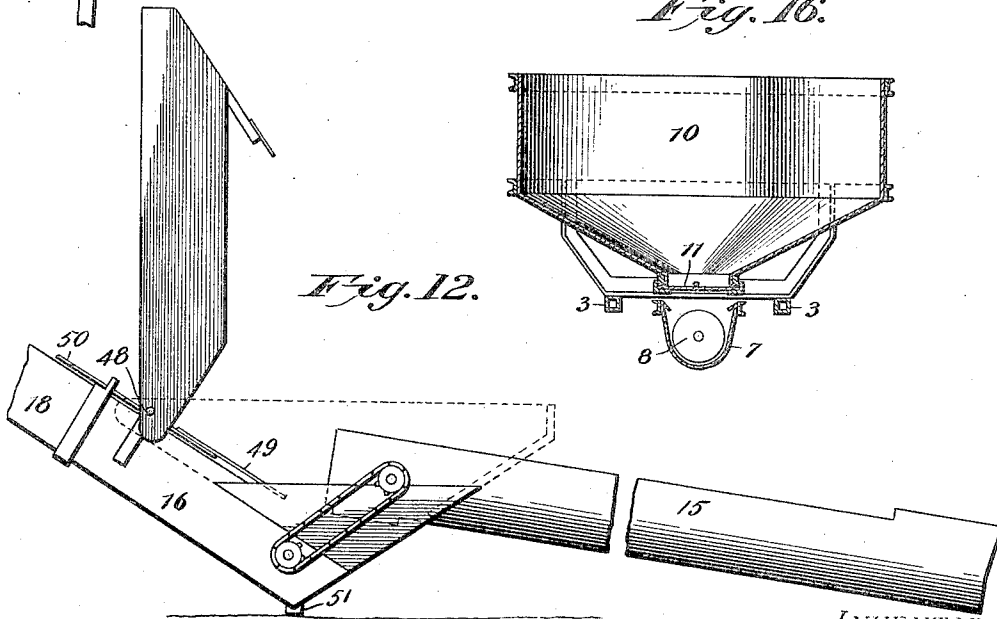

Fig. 12.



WITNESSES:

E. H. Walker
Shepherd Patton

INVENTOR

Warren Watts

BY

H. W. Stackpole

Attorney

UNITED STATES PATENT OFFICE.

WARREN WATTS, OF CLAY CENTER, KANSAS.

PORTABLE GRAIN-ELEVATOR.

SPECIFICATION forming part of Letters Patent No. 688,912, dated December 17, 1901.

Application filed June 17, 1901. Serial No. 64,835. (No model.)

To all whom it may concern:

Be it known that I, WARREN WATTS, a citizen of the United States, residing at Clay Center, in the county of Clay and State of Kansas, have invented certain new and useful improvements in Portable Grain-Elevators; and I do declare the following to be a full, clear, and exact description of the invention, such as will enable others skilled in the art to which it appertains to make and use the same, reference being had to the accompanying drawings, and to the figures of reference marked thereon, which form a part of this specification.

My invention relates to grain-elevators; and its object is to provide one which is portable to adapt it for use wherever needed, which may be folded to occupy very little space, and which, by means of its adjustable parts, may be swung from one position to another to suit the requirement of the machine to perform its best work.

My invention is more particularly adapted to facilitate in delivering the grain from wagons or threshing-machines to a considerable height above them into receptacles, such as granaries, bins, cars, &c.; and it consists in the construction, combination, and arrangement of parts, as will be more fully described hereinafter, and particularly pointed out in the claims.

In the drawings which illustrate my invention, Figure 1 is a side elevation of the machine complete, a portion of the conveyer being shown in dotted lines folded ready for transportation. Fig. 2 is a vertical longitudinal sectional view of the machine, showing the interior elevating mechanism. Fig. 3 is a top plan view of the truck-frame with the elevating mechanism removed. Fig. 4 is a cross-section of the hopper which receives the grain from the wagons or threshers. Fig. 5 is a detail showing the mechanism for folding the upright conveyer to the position shown in dotted lines in Fig. 1. Fig. 6 is an elevation of the pole which supports the conveyer when in a folded position, as shown by dotted lines in Fig. 1. Fig. 7 is a cross-section taken through one of the conveyer-tubes. Fig. 8 is a side elevation of one of the flights of the conveyer attached to an endless chain. Fig. 9 is a perspective view of one of the flights of

the conveyer detached. Fig. 10 is a detail showing the manner of connecting one of the conveyers to its support. Fig. 11 is a plan view of the plate which controls the movement of the swinging crane. Fig. 12 is a side elevation of the receiving-hopper when the upper sliding portion is removed and the horizontal upper conveyer 15 is attached thereto and showing the hinged portion of the hopper thrown up. Fig. 13 is an end elevation of Fig. 5 when the main conveyer is folded. Fig. 14 is a longitudinal section of the rotatable gear-frame which is mounted on the truck-frame and from which the several conveyers are operated. Fig. 15 is a cross-section of Fig. 14. Fig. 16 is a cross-section through the hopper and the screw conveyer.

Like numerals of reference indicate corresponding parts throughout the several views.

In carrying out the invention the essential parts of the mechanism adapting the machine particularly for conveying grain may be arranged in any convenient form of frame. However, the preferred embodiment of the invention is shown in the drawings, in which the working parts of the machine are illustrated as being upon a frame 1, provided with two longitudinal sills 2 and 3, carried by the axles 4, on which are journaled the wheels 5. The sills may be further braced upon the rear axle by means of the braces 6, forming a strong and durable frame for supporting the working parts of the elevators. Mounted between the longitudinal sills is a casing 7, in which is mounted a screw conveyer 8, the shaft of which extends through the casing at one end and is provided with a suitable pulley 9, which may receive a belt to drive a fanning-mill when it is desired to convey the grain from a bin or granary to the fanning-mill to clean it, the construction of which will be described later on.

Mounted upon the top of the casing 7 is a hopper 10, which conducts the grain to the screw conveyer and which is provided at the bottom with a sliding valve-door 11, operated by means of a handle 12. The main elevator 13 connects at its bottom with the screw conveyer and extends upwardly to a considerable height above the machine and is provided at its upper end with a hood 14, having an open-

ing in the bottom to allow the grain to fall into the upper section of the horizontal elevator 15, from which the grain is discharged into the granary or bin through the opening 5 15^a at its outer extreme end. This upper section of the top portion of the main elevator may be folded to the position shown in dotted lines in Fig. 1 when the machine is not in use and ready to be transported from place to 10 place. Each section is provided with a sprocket at each end, over which an endless chain revolves, carrying the flights or cups which convey the grain.

In Fig. 1, A represents the end of a wagon, 15 the tail-gate being removed, and from which the grain is dumped into a receiving-hopper 16, which is provided with an upper section 17, one side of which is almost horizontal, to extend under the wagon-body, as shown at 20 17^a in Fig. 4. To the bottom of this receiving-hopper is attached the conveyer 18, which extends upwardly over the hopper 10, into which it conducts the grain. The grain is then admitted to the screw conveyer 8, when 25 it is caught by the main elevator and conducted to the upper section 15, as before described. The conveyer 18 is swiveled within a suitable frame above the hopper 10 to adapt it to be thrown upon either side of the frame, 30 as shown in dotted lines in Fig. 1, or to the most convenient position for the wagon.

Mounted near the rearward end of the frame upon the longitudinal sines are the cross-pieces 19, which support a gear-frame 35 20, the lower end of which provides bearings for the shaft 21, to which the power is attached. This gear-frame is rotatably mounted within a suitable upright bearing 23, secured to the cross-pieces 19. The rotatable 40 gear-frame is provided with a collar 24, keyed upon the vertical portion thereof and provided with a horizontal flange, through which is formed a series of apertures 23^a and in which apertures a pin may be inserted to 45 engage the apertures in the stationary upright bearing to lock the frame in the desired position or in alinement with the driving power. The horizontal driving-shaft 21 has mounted thereon a beveled gear 25, 50 which meshes with a bevel-gear 26, which imparts motion to the second bevel-gear 26^a. Mounted upon the cross-pieces 19 are suitable standards 27, which provide bearings for the counter-shaft 28 and which counter- 55 shaft has rigidly attached thereto a bevel-gear 29, meshing with the bevel-gear 26^a. This counter-shaft carries a sprocket 30 and a belt-pulley 31. The former is connected by a sprocket-chain to the sprocket 32 on the 60 horizontal shaft journaled in the frame of the crane and revolves the vertical shaft 33 through the bevel-gears 32 and 33^b at the base of the crane. At the top of the vertical shaft 33 is mounted a sprocket 34, which is 65 connected by sprocket-gearing to the sprocket 35, mounted on a suitable rotatable bearing at the end of the crane. On the lower end

of the shaft to which the sprocket 35 is keyed is mounted a bevel-gear 36, meshing with its mate 37 and connected with the sprocket 38 70 in the elevator-tube 18 by a sprocket-chain. This communicates motion to the endless chain within the elevator-tube 18, which endless chain rides over the sprocket 39 at the bottom of the tube. 75

The pulley 31 upon the counter-shaft 28 is connected by a belt 40^a to a pulley 40, mounted on a shaft at the top of the main elevator-tube 13 and through which the endless chain carrying the flights receives its motion, the 80 endless chain riding over a suitable sprocket 41 at the bottom of the main elevator 13 and adjacent the end of the screw conveyer. The horizontal elevator 15, which receives the grain from the main elevator, is likewise pro- 85 vided at each end with sprocket-wheels over which the endless chain carrying a series of flights travels, and this endless chain receives its power from the pulley 40 through a suitable sprocket-gearing 42. 90

The shaft or screw conveyer has its bearings in suitable hangers 43, depending from the truck-frame, and upon this shaft is mounted a bevel-gear 44, meshing with the bevel-gear 45. The shaft of the bevel-gear 45 95 extends transversely across the gear-frame and has secured thereon a sprocket 46, which connects by a sprocket-chain 46^a to the sprocket-wheel 47 upon the end of the counter-shaft 28.

It will be seen that the power is applied to 100 the machine through the shaft 21, which imparts motion to the various parts of the machine through the intermeshing gears and the counter-shaft 28, the countershaft 28 being provided with a belt-pulley and two sprocket- 105 wheels, one sprocket-wheel operating the conveyer 18 through suitable sprocket-gearing and the other sprocket-wheel 47 operating the screw conveyer through the sprocket 46 and bevel-gearing 44 and 45, while the pulley on 110 the counter-shaft connects with the pulley in the main elevator 13 and the horizontal upper elevator 15.

The wagon containing the grain is backed to a convenient position above the receiving- 115 hopper 16, as shown in Fig. 1, into which the grain is dumped, when it is caught by the flights of the inclined elevator 18 and conducted to the central hopper 10, mounted on the frame. This receiving-hopper is provided 120 with an upper sliding section 17, which has one side offset to fit under the wagon-body, as shown in Fig. 4. The base of the sliding portion is provided with suitable cleats 47^a, which engage the edge of the hopper and 125 limit its sliding movement. The distance the section may be slid, however, is sufficient to allow the hopper to assume the correct position under the wagon-body after the wagon has been backed against the same, and it is 130 guided in its movement by these cleats 47^a, which are secured to the one member and extend below in engagement with the sides of the stationary portion of the hopper. The

stationary portion of the hopper is formed of two sections, the upper one of which is hinged to the elevator-tube 18, as shown at 48 in Fig. 12. When the sliding portion is removed, this hinged section may be thrown upward, as shown in Fig. 12. The above arrangement of hopper may be used when it is desired to convey the grain from the bottom of a bin or granary, in which case the horizontal conveyer 15 is removed from its normal position at the top of the elevator and attached to the receiving-hopper and connected with the sprocket to the bottom of the same by a suitable chain, as shown in Fig. 12. The free end of the upper section is adapted to lie upon the floor or at the lowermost point of the bin, as shown in Fig. 12. The bottom of the hopper is formed of downwardly-converging sides, one of which has fitted therein a sliding valve 49, provided with a handle 50, which extends upwardly beside the conveyer-tube 18 within convenient reach of the operator, and when the valve is pushed inward the supply of grain to the conveyer 18 is cut off. It will be seen that the supply of grain can be controlled at will by the regulation of this valve. The base of the receiving-hopper is provided with a suitable foot 51, upon which it rests.

Mounted upon the truck-frame is a frame 52, supporting a swinging crane 53. This swinging crane is mounted in suitable bearings on the side of the frame 52 and has attached thereto a horizontally-disposed plate 54, lying parallel with the top of the frame. The plate 54 and the top of the frame are provided with a series of apertures arranged in the arc of a circle and are in vertical alignment with each other, so that a pin may be inserted within the apertures to hold the crane at any angle desired. By this construction it will be seen that the crane 53 may be thrown entirely around to any convenient position and when thus thrown will be held in the desired position, as the locking-pin is in engagement with the apertures in the plate and the top of the frame. The crane is constructed of metallic tubing and comprises a vertical arm and a horizontal arm. Within the vertical arm is mounted a concentric shaft 33, to which is secured the bevel-gear 33^a, which meshes with the bevel-gear 33^b on the horizontal shaft journaled in the frame 52, as before described. The rotary motion imparted to the shaft 55 through the bevel-gears at the base of the frame operates the sprocket 35 through the sprocket 34 at the top of the shaft 33. The horizontal arm of the crane is provided on its extreme end with a swivel-bearing 57, through which the shaft 58, carrying the sprocket-wheel 35 and the bevel-gear 36, revolves, the bevel-gear 36 meshing with its mate 37 and connected to the sprocket in the conveyer 18 and operates the endless chain in said conveyer 18. It will be seen that by means of the swivel-bearing 57 the conveyer 18 may be thrown around to any desired position or to the other side of

the machine, as shown in dotted lines in Fig. 1, without stopping the operation of the machine or interfering with the same, as the shaft 58 revolves within the bearing 57 independently of its swivel movement. Intermediate the ends of the horizontal arm is mounted a chain-tightener 59. The conveyer 18 is hung upon the bearing by suitable links 60. Each link is provided with a circular aperture at one end to fit upon the boss of the bearing 57 and at its other end is formed a longitudinal slot 61, in which the shaft carrying the sprockets 38 may be slid back and forth to tighten or loosen the conveyer-chain, as occasion requires. Mounted upon the frame 52 is a windlass 62, having the usual crank-handle and pawl-and-ratchet mechanism and upon which may be wound a rope 63, connected with the horizontal upper conveyer 15. This rope extends alongside the main conveyer 13, passing over a pulley 64, mounted above the main conveyer, and its end is attached to the horizontal conveyer 15. When the windlass is turned to wind in the rope, the horizontal conveyer is elevated to a position higher or above the main elevator or it may be lowered to any desired position.

Mounted upon the truck-frame above the screw conveyer is a circular hopper 10, into which the grain is dumped as it leaves the conveyer 18. The hopper is formed with a downwardly-inclined bottom having a central opening therein, through which the grain passes to the screw conveyer. This hopper is provided with a sliding valve 11, mounted above the opening and controls the supply of grain to the screw conveyer. The hopper is readily detachable from the frame, and when it is desired to clean the grain before it is stored into a granary a cleaning-mill may be attached to the top of the frame in the position that the hopper occupies in the drawings, and as the grain passes from the conveyer 18 it is deposited within the cleaning-mill, which conducts it to the screw conveyer. The application of the cleaning-mill will not necessitate the derangement of the other parts of the machine other than the hopper. The cleaning-mill is usually desired when the upper section 15 is attached to the receiving-hopper and the grain is taken from the floor or bottom of a bin, as shown in Fig. 12.

Each of the conveyers is formed of two semicircular outer plates 66, overlapping each other at the ends and secured together by a bolt or rivet, a cross-section of the conveyer being shown in Fig. 7. The rivet which holds the sections together also holds a piece of channel-steel 67 within the tube and which channel-pieces act as guides for the flights of the conveyers. Each flight is formed from a semicircular plate 68, corresponding in shape to one-half of the interior of the tube 66, and each plate is provided with a flanged portion 69 and a central recess 70. The links

of the chain are provided with lateral extensions 71, which engage the face of the flights and afford a means of attaching the same thereto, which may be by means of rivets, as shown in Fig. 7. One end of the link extends within the recessed portion 70, while the other end extends upon the other side of the recessed portion and connects with the next adjoining link. By forming the recesses in the flights the chain is permitted to come nearer the center of the load, and a larger sprocket may be used at the heads of the elevators. The form of flight and the manner of attaching the same to the chain are shown in Figs. 7, 8, and 9.

The main-elevator tube 13 is formed of two sections joined together near the middle portion thereof, and when the machine is not in use and it is desired to convey the same from one place to another the top section of the main elevator 13 and the horizontal upper section 15 may be folded down to the position shown in dotted lines in Fig. 1. In order to facilitate and conveniently fold the parts in this position or raise them to the position in full lines, I have devised a novel mechanism, which will be hereinafter described, and shown in Fig. 5. The two sections are hinged to the supporting-arm 74 at a point 75, the supporting-arm resting on the end of the truck-frame and extending upwardly beyond the hinged part 75 and provided at its end with an eye 76. Upon the supporting-arm 74 is a block 74^a, having pulleys 77 and 77^a therein. These pulleys form the guides for a rope or cable 78, connected to the windlass 79 at the base of the supporting-arm. This windlass is provided with the usual crank-arm and ratchet mechanism. The other end of the cable is securely fastened to the end of the lever 80, which is pivoted at 75 to the supporting-arm 74. The lever is provided with an extension 81, which forms a saddle for the upper section 15 when folded into the position shown in Fig. 5, and the end of this lever supports a stay-rod 82, which is connected at one end to the end of the lever and at the other end to the upper section of the conveyer 13. A spring 77^b is secured at one end to the opening 76 in the end of the supporting-arm 74, and its other end is fastened to the upper section of the conveyer 13. This spring aids in raising the elevator as it is released of its tension with the parts when in a raised position. Assuming the parts to be in the position shown in Fig. 5 and it is desired to raise the elevator when the windlass is revolved, the end of the lever 80 will follow the arc indicated by dotted lines in Fig. 5 until it reaches a point opposite the pulleys 77 and 77^a, when the pulley 77^a will take the cable and the end of the lever will pass to the position shown in dotted lines in Fig. 5, carrying with it its extension or saddle 81, which will likewise assume the position shown in dotted lines in Fig. 5. The horizontal conveyer 15 may be raised by

the operation of the windlass 62 on the frame 52 through the medium of the rope 63. When the parts are raised to the position shown in full lines in Figs. 1 and 2, they may be locked together by inserting a pin at 90. A reverse operation will fold the parts. When the parts are folded to the position shown in Fig. 1, the end of the main conveyer 13 is supported upon a suitable arm 91, provided at the top with a stirrup 92, in which the tubular casing of the conveyer rests. A strap 92^a may be used to entirely envelop the conveyer-tube and hold it within the stirrup. This arm is fitted within a socket 93 at one end of the frame and may be detached therefrom at will. A plan view of the arm is shown in Fig. 6.

From the foregoing it is thought that the construction, operation, and many advantages of the herein-described machine will be readily apparent without further description, and it will be understood that various changes in the form, proportion, and construction of parts may be resorted to without departing from the spirit or sacrificing any of the advantages of the invention.

Having thus described my invention, what I claim, and desire to secure by Letters Patent, is—

1. In a grain-elevator, a suitable supporting truck-frame, a screw conveyer mounted within the frame, a foldable inclined conveyer connected with the screw conveyer, an auxiliary horizontal upper conveyer carried by the inclined conveyer and adapted to fold therewith, and mechanism for folding and raising the conveyers.
2. In a grain-elevator having a suitable supporting truck-frame, the screw conveyer mounted within said frame, the inclined folding conveyer 13 connected with said screw conveyer and the swinging conveyer 18 adapted to supply said screw conveyer, substantially as shown and described.
3. In a grain-elevator, a suitable supporting truck-frame, a screw conveyer mounted within the frame, a vertical conveyer connected with the screw conveyer, and a horizontal auxiliary conveyer carried by the inclined conveyer a swinging conveyer adapted to supply the screw conveyer and carrying at its lower end a receiving-hopper, and means for operating all of the conveyers from one source of power.
4. In a grain-elevator, a suitable supporting truck-frame having a screw conveyer mounted therein and an inclined conveyer connected with the screw conveyer, a detachable hopper mounted upon the frame above the screw conveyer, an inclined conveyer rotatably supported above the hopper and provided at its lower end with a receiving-hopper, means for swinging said inclined conveyer upon either side of the truck-frame, and means for operating all of the conveyers from one source of power.
5. In a grain-elevator, the combination with

a supporting truck-frame, of a main conveyer extending from the bottom of the frame to a point above the top, an auxiliary conveyer carried by said main conveyer, and means for folding the upper portion of the main conveyer and the auxiliary conveyer; combined with means for raising the auxiliary conveyer independently of the main conveyer.

6. The combination with a supporting truck-frame, of a main conveyer extending from the bottom of the frame to a point above the top, an auxiliary detachable horizontal conveyer carried by the main conveyer and adapted to be raised and lowered, a screw conveyer mounted within the truck-frame and adapted to deliver grain to the main conveyer, a hopper detachably mounted upon the frame above the screw conveyer, and an inclined conveyer to supply said hopper.

7. In a grain-elevator, a suitable supporting truck-frame, a screw conveyer mounted within the frame, an inclined conveyer connected with the screw conveyer, a hopper detachably mounted upon the frame above the screw conveyer, and provided with a cut-off slide to control the feed to the screw conveyer, a swinging crane extending above the frame over the hopper, an inclined conveyer carried by said crane and adapted to deliver grain into the hopper, and a receiving-hopper attached to the end of the inclined conveyer, and means for operating all of the conveyers from one source of power.

8. In a grain-elevator, a suitable supporting truck-frame having main longitudinal sills carried by the transverse axles, wheels mounted upon the axles to adapt the machine to be moved from place to place, a screw conveyer mounted within the frame, an inclined main conveyer connected to the screw conveyer, an auxiliary horizontal upper conveyer carried by the main conveyer, an inclined conveyer supplying the screw conveyer, a gear-frame rotatably mounted upon the sills of the frame and carrying gearing which is connected by suitable sprocket-gearing to each of the conveyers for operating the latter.

9. In a grain-elevator, a suitable supporting truck-frame, a suitable conveyer mounted within the frame, an inclined conveyer connected with a screw conveyer, an inclined swinging conveyer carrying at its lower end a receiving-hopper provided with an upper slidable section and a hinged intermediate portion, substantially as described.

10. The combination in a grain-elevator, of an inclined conveyer carrying at its lower end a receiving-hopper, and having an upper slidable detachable portion provided with a lateral horizontal side, the lower portion of said receiving-hopper formed with a stationary base and an upper section which is hinged to the inclined conveyer provided with a sliding cut-off valve, substantially as described.

11. In a grain-elevator, a suitable supporting truck-frame, a screw conveyer mounted

within the frame, an inclined conveyer connected with the screw conveyer, an inclined conveyer rotatably mounted above the frame, a hopper detachably mounted upon the truck-frame beneath the discharge end of the inclined conveyer and provided with a cut-off slide to control the feed of the grain to the screw conveyer, and means for operating all of the conveyers from a suitable gear-frame mounted on the truck-frame to which each conveyer is connected by suitable gearing, substantially as described.

12. A grain-elevator provided with endless conveyers, each of which is inclosed within a circular casing formed from two semicircular plates connected at their edges, sprockets suitably mounted at the ends of each conveyer, an endless chain operated by said sprockets, flights carried by the endless chain, and means for guiding the flights in the casing, substantially as set forth.

13. A grain-elevator provided with endless conveyers, each of which is inclosed within a circular casing formed from two semicircular plates connected at their edges, longitudinal channel-bars held within the casing at the joint of the semicircular plates, an endless chain carrying flights and which flights are formed from a semicircular plate provided on its straight edge with flanges and a central recess, the links of the chain provided with laterally-extended ears secured to the semicircular plate, said links lying in the central recess, whereby the chain is permitted to come nearer the center of the load, substantially as described.

14. In a grain-elevator having a suitable supporting truck-frame, the main upright conveyer consisting of two sections joined together near the middle portion thereof, the upper section hinged to the stationary supporting-arm and means mounted upon said truck-frame for folding and raising said upper section, substantially as shown and described.

15. In a grain-elevator, a suitable supporting truck-frame, a foldable inclined conveyer, and an auxiliary horizontal upper conveyer carried by the main conveyer, means connected with the truck-frame for raising the auxiliary conveyer, and means connected with the truck-frame for folding the upper section of the main conveyer and the horizontal conveyer.

16. In a grain-elevator, a suitable supporting truck-frame, a screw conveyer mounted within the frame, a swinging crane carried by the truck-frame and supporting an inclined conveyer, an inclined foldable conveyer connected with the screw conveyer and carrying at its upper end a horizontal upper section, suitable supports connected with the truck-frame and the main conveyer, a lever pivotally attached to said support and provided with a right-angular extension, a spring connected to the end of the support and to the upper section

of the main conveyer, a rope or cable attached
at one end to the lever and its other end to the
windlass on the truck-frame, said lever adapt-
ed to be operated through the rope to fold or
5 raise the upper section of the main conveyer
and the horizontal conveyer carried thereby,
substantially as described.

In testimony whereof I have affixed my sig-
nature in presence of two witnesses.

WARREN WATTS.

Witnesses:

HY. W. STACKPOLE,
P. E. PARROTT.