



INTERNATIONAL APPLICATION PUBLISHED UNDER THE PATENT COOPERATION TREATY (PCT)

<p>(51) International Patent Classification <sup>6</sup> : <b>B01L 11/00, B65G 47/14, G01N 35/10 // C12Q 1/02, 1/04</b></p>	<p>A1</p>	<p>(11) International Publication Number: <b>WO 98/24549</b> (43) International Publication Date: 11 June 1998 (11.06.98)</p>
<p>(21) International Application Number: PCT/EP97/06948 (22) International Filing Date: 1 December 1997 (01.12.97) (30) Priority Data: 9625150.9 4 December 1996 (04.12.96) GB (71) Applicant (for all designated States except US): SMITHKLINE BEECHAM PLC [GB/GB]; New Horizons Court, Brentford, Middlesex TW8 9EP (GB). (72) Inventors; and (75) Inventors/Applicants (for US only): MARLOW, John, Barry [GB/GB]; SmithKline Beecham Pharmaceuticals, New Frontiers Science Park South, Third Avenue, Harlow, Essex CM19 5AW (GB). PALLETT, Mark, Jeffrey [GB/GB]; SmithKline Beecham Pharmaceuticals, New Frontiers Science Park South, Third Avenue, Harlow, Essex CM19 5AW (GB). LLOYD, Paul, Stephen [GB/GB]; SmithKline Beecham Pharmaceuticals, New Frontiers Science Park South, Third Avenue, Harlow, Essex CM19 5AW (GB). (74) Agent: WALKER, Ralph, Francis; SmithKline Beecham, Corporate Intellectual Property, New Horizons Court, Brentford, Middlesex TW8 9EP (GB).</p>		<p>(81) Designated States: CA, JP, US, European patent (AT, BE, CH, DE, DK, ES, FI, FR, GB, GR, IE, IT, LU, MC, NL, PT, SE).  <b>Published</b> <i>With international search report. Before the expiration of the time limit for amending the claims and to be republished in the event of the receipt of amendments.</i></p>

(54) Title: DEVICE FOR TRANSFER AND SEPARATION OF MICROBEADS

(57) Abstract

A device for transferring beads from a source containing a plurality of beads to a receptacle for beads comprising a body having bead receiving cavities which can only fully contain one bead. Beads are fed into these cavities via a bead entry conduit, and exiting via a bead exit conduit into a receptacle for the beads. The device facilitates transfer of small beads, e.g. from chemical reactions, into receptacles in a defined manner.

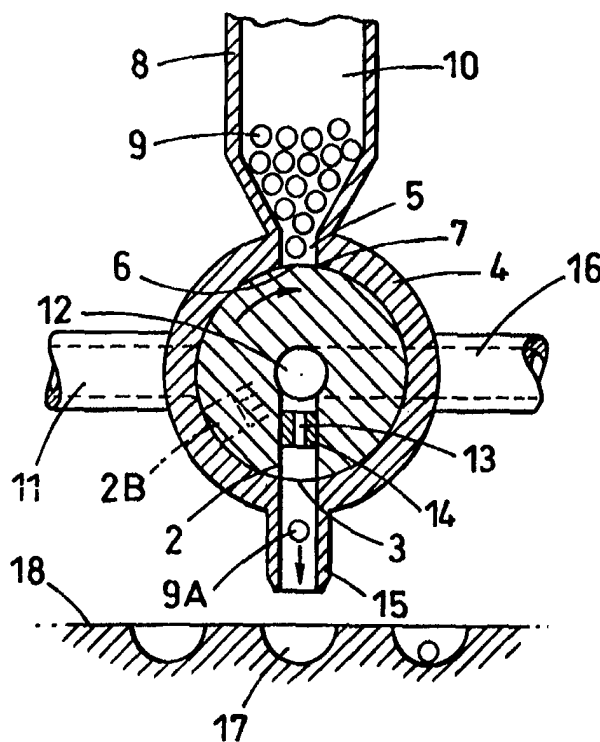

*FOR THE PURPOSES OF INFORMATION ONLY*

Codes used to identify States party to the PCT on the front pages of pamphlets publishing international applications under the PCT.

AL	Albania	ES	Spain	LS	Lesotho	SI	Slovenia
AM	Armenia	FI	Finland	LT	Lithuania	SK	Slovakia
AT	Austria	FR	France	LU	Luxembourg	SN	Senegal
AU	Australia	GA	Gabon	LV	Latvia	SZ	Swaziland
AZ	Azerbaijan	GB	United Kingdom	MC	Monaco	TD	Chad
BA	Bosnia and Herzegovina	GE	Georgia	MD	Republic of Moldova	TG	Togo
BB	Barbados	GH	Ghana	MG	Madagascar	TJ	Tajikistan
BE	Belgium	GN	Guinea	MK	The former Yugoslav Republic of Macedonia	TM	Turkmenistan
BF	Burkina Faso	GR	Greece			TR	Turkey
BG	Bulgaria	HU	Hungary	ML	Mali	TT	Trinidad and Tobago
BJ	Benin	IE	Ireland	MN	Mongolia	UA	Ukraine
BR	Brazil	IL	Israel	MR	Mauritania	UG	Uganda
BY	Belarus	IS	Iceland	MW	Malawi	US	United States of America
CA	Canada	IT	Italy	MX	Mexico	UZ	Uzbekistan
CF	Central African Republic	JP	Japan	NE	Niger	VN	Viet Nam
CG	Congo	KE	Kenya	NL	Netherlands	YU	Yugoslavia
CH	Switzerland	KG	Kyrgyzstan	NO	Norway	ZW	Zimbabwe
CI	Côte d'Ivoire	KP	Democratic People's Republic of Korea	NZ	New Zealand		
CM	Cameroon		Republic of Korea	PL	Poland		
CN	China	KR	Republic of Korea	PT	Portugal		
CU	Cuba	KZ	Kazakstan	RO	Romania		
CZ	Czech Republic	LC	Saint Lucia	RU	Russian Federation		
DE	Germany	LI	Liechtenstein	SD	Sudan		
DK	Denmark	LK	Sri Lanka	SE	Sweden		
EE	Estonia	LR	Liberia	SG	Singapore		

## DEVICE FOR TRANSFER AND SEPARATION OF MICROBEADS

This invention relates to a novel device, being an device for transferring polystyrene resin beads from a source which contains a number of such beads to a receiver for such beads.

5           In chemistry and biochemistry chemical reactions are frequently performed on the surface of small polystyrene resin beads, typically 250-300 microns in diameter. For example a coating of an active substance may be chemically absorbed onto the surface of such a bead, the coated bead may then be exposed to further active substances, and the occurrence of an interaction between the  
10 substances can be detected by monitoring the surface of the bead. This technique is particularly useful in biological sciences where only minute amounts of such active substances may be available, and in the investigation of combinatorial chemistry libraries.

          In such techniques it is usually necessary to transfer individual beads from a  
15 source containing many such beads, e.g. a slurry of the beads in a solvent, into defined locations in a receptacle, for example individual vials, or individual wells in a microtitre plate.

          A number of problems hinder this. The small size of the beads makes them difficult to manipulate. Some active substances cause the surface of the beads to  
20 become sticky, causing them to clump together, making it difficult to transfer discrete individual beads. It is difficult to transfer beads using present techniques without at the same time transferring a relatively large quantity of solvent. At present either manual methods, e.g. picking out single beads by hand, or excessively complex devices are used. WO 94/28119 discloses an device for  
25 distinguishing between large beads, in which selected beads may be directed along a selected flow channel. There is a need to provide a device which will, in part at least, overcome the problems of handling such beads.

          According to the invention a device for transferring beads from a source containing a plurality of beads to a receptacle for beads comprises:

30           a body having a bead receiving cavity in its surface, the cavity having an opening at a surface of the body, the cavity being of dimensions such that it can

only fully contain one bead, beads in excess of one projecting for at least one third of their diameter above the surface,

a bead entry conduit in communication with, or capable of being brought into communication with, the source and capable of allowing beads to pass along the bead entry conduit towards the body, the bead entry conduit terminating in an orifice bounded by a lip,

the opening and the orifice being relatively moveable into communication with each other to allow beads to pass from the bead entry conduit into the cavity, and being thereafter relatively moveable out of communication, the surface of the body and the lip being in moveable contact with each other such that when the opening and the orifice move out of communication with each other beads in the cavity in excess of one bead are removed from the cavity and the bead entry conduit is closed by the surface of the body,

a bead exit conduit in communication with, or capable of being brought into communication with, a receptacle for the beads,

the opening and the bead exit conduit being relatively moveable into communication with each other to allow a bead contained in the cavity to pass from the cavity into the bead exit conduit,

means to direct one or more beads from the bead entry conduit into the cavity, and

means to direct a bead from the cavity into the bead exit conduit.

Suitably beads removed from the cavity as described above are retained in the bead entry conduit.

Preferred embodiments of the invention are described below.

Preferably the body is a circular section body, for example of substantially cylindrical or frustro-conoidal shape, enabling the bead entry conduit and bead exit conduit to be provided in a correspondingly circular-section casing within which the body closely fits, and within which the body can rotate, the body surface thereby sliding across the internal surface of the casing. Typically such a construction may be of a circular section plug and surrounding sleeve arrangement.

The bead receiving cavity is preferably of dimensions such that at least half of the diameter of beads in excess of one in the cavity projects above the body

surface. Suitably the cavity may be a cylindrical cavity. Preferably such a cylindrical cavity has a diameter of no larger than ca.1.65x the diameter of the beads and a depth from the surface of the body of no more than ca.1.65x the diameter of the beads. In the case of the above-mentioned beads of diameter 250-  
5 300 microns such a cylindrical cavity may have a diameter of ca. 400 microns and a depth from the surface of ca. 400 microns. In a circular section body, the cavity preferably has its opening in a circumferential surface of the body.

Preferably the surface of the body and the lip are in slideably moveable contact with each other, and the lip and opening can thereby move relative to each  
10 other in a direction perpendicular to the depth of the cavity, and the lip thereby moves across the opening to sweep beads in excess of one from the cavity back into the bead entry conduit. When the bead entry conduit is provided in a circular-sectional casing, e.g. in the sleeve of a plug and sleeve arrangement as described above, this conduit may be a passage through the casing, terminating in an orifice  
15 opening in the internal surface of the casing, the internal surfaces of the edge of the orifice forming the lip. Rotation of the body within the casing provides the above-described slideably moveable contact.

The source of beads may be a reservoir communicating with the bead entry conduit. For example a reservoir may comprise a small container, or a reaction  
20 vessel, containing a slurry of the beads in a suitable liquid vehicle such as methanol as commonly used. The bead entry conduit may be made connectable with a mouth opening or other opening of a vessel to facilitate communication, cleaning, replenishment with fresh beads etc. Alternatively the source may comprise a bead feeding line from, for example, a reaction vessel or bead storage vessel. Beads may  
25 be fed into the bead entry conduit by gravity, or additionally or alternatively beads may be fed into the bead entry conduit by means of fluid flow or fluid pressure etc. of a fluid they are suspended or slurried in. The bead entry conduit can have dimensions convenient for its application, for example wide enough to allow beads to pass along its length without jamming together.

30 When the body is a circular section body and the bead entry conduit is provided in a circular sectional casing as defined above, the cavity opening and the bead entry conduit may be brought into and out of communication by rotation of the

body within the casing. In this arrangement, if beads in excess of one enter the cavity such that the excess beads project above the surface of the body, when the body rotates within the casing to move the cavity and orifice out of communication, the lip formed by the edge of the orifice will sweep excess beads out of the cavity  
5 and back into the bead entry conduit. In this way only one bead remains within the cavity. Also if the beads have a tendency to stick together this sweeping action can separate them.

When the bead exit conduit is provided in a circular sectional casing as described above, this conduit may also be a passage through the casing. The bead  
10 exit conduit may for example be a tube, and the bead exit conduit and a receptacle for the beads may be moveable relative to each other to deposit a bead into a defined location. For example the receptacle may be a vessel, and vessels may be sequentially brought into communication with the bead exit conduit so that each bead is deposited in an identifiable location or vessel. For example the receptacle  
15 may be a well in a microtitre plate, and the conduit and the plate may be relatively moveable about X-Y axes to allow one or a desired number of beads to be deposited in a well of defined location.

When the bead exit conduit is provided in a circular casing as described above, the conduit and the opening may be brought into and out of communication  
20 by rotation of the body within the casing.

The means to direct one or more beads from the bead entry conduit into the cavity may comprise gravity, in that the conduit and its orifice may be positioned above the opening of the cavity when they are in communication. Additionally or alternatively the means may comprise some driving means to positively urge beads  
25 into the cavity. A preferred driving means comprises the application of reduced pressure to the cavity to suck beads into the cavity. This may be achieved by the provision of a small conduit in a lower part of the cavity, of too small dimensions to allow a bead to enter it, and via which reduced pressure may be applied when the cavity and bead entry conduit are in communication. The reduced pressure may be  
30 discontinued when the conduit and cavity are out of communication. For example this may be achieved by means of the small conduit and a vacuum application line moving relative to each other into communication when the opening and the orifice

are in communication, and moving relative to each other out of communication when the orifice and opening move out of communication.

The means to direct a bead from the cavity into the bead exit conduit preferably comprises a driving means. A preferred driving means is a driving fluid directed into the cavity to drive a bead out of the cavity. A preferred driving fluid is air as this can help to remove excess liquid vehicle from the bead e.g. by evaporation or dispersal. The driving fluid may conveniently be applied by means of the above mentioned small conduit, which when the cavity and bead exit conduit are in communication can be used to direct pressurised driving fluid into the lower part of the cavity to drive a bead out through the opening of the cavity. Such a driving fluid can additionally serve to direct the bead along the bead exit conduit towards and into the receptacle. The application of driving fluid may be discontinued when the conduit and cavity are out of communication. For example this may be achieved by means of the small conduit and a driving fluid application line moving relative to each other into communication when the opening and the bead exit conduit are in communication, and moving relative to each other out of communication when the opening and bead exit conduit move out of communication.

In operation, the body may be moved e.g. in the case of a circular sectioned body rotated into a first position, such that the orifice and opening are in communication, to allow beads to enter the cavity. If necessary the body may be stopped e.g. momentarily if necessary, in this position for long enough for one or more beads to enter the cavity e.g. under the action of the driving means. The body may then be further moved into a second position so that the opening and orifice are out of communication, and as this takes place beads in excess of one are removed from the cavity, for example by the action of the lip of the orifice moving across the opening as described above. The body may then be moved into a third position such that the opening and the bead exit conduit are in communication with each other to allow a bead to exit the cavity and pass into the bead exit conduit. The body may be stopped e.g. momentarily if necessary, in this position for long enough for a bead to pass from the cavity into the bead exit conduit, e.g. under the action of a driving fluid. The body may then be moved into a fourth position so that the

opening and bead exit conduit are out of communication, and the procedure repeated so as to return the body into the first position described above. When the body is a circular section body as described above the above described movements may be achieved by the said first, second, third and fourth positions being located sequentially circumferentially on a rotation cycle.

The device of the invention may comprise one or more bead receiving cavities in its surface. In the case of a circular sectioned body each of two or more bead receiving cavities may be brought into communication sequentially with a bead entry conduit and then brought into communication with a bead exit conduit. In this way the speed of operation and/or the capacity of the device in terms of the rate of bead handling may be increased.

The device of the invention may be made of conventional materials, such as low friction plastics and/or metals.

The device of the invention is capable of being automated, for example, a computer may control one or more motors which cause the relative movements of the above-mentioned elements of the invention, and such control may involve the incorporation of sensors at various points in the device to detect the presence or absence of beads at particular locations in the device, and/or the presence of more than one bead when only one should be present. An automated form of the device of this invention may be programmed, e.g. to deliver predetermined numbers of beads to particular receptacle(s) or in other ways. Stepping motors, i.e. which rotate through a defined rotation angle upon each activation, are particularly suitable for operating a rotatable body of the type described above. Automated forms of the device are encompassed within the scope of this invention.

Although intended primarily for use in transferring polymeric beads of the above-mentioned type e.g. the product of combinatorial chemistry, the device of this invention is also suitable for transferring other types of particulate matter, e.g. of chemical or biological materials.

Consequently in a further aspect the invention provides a method of use of a device as described above in a process for the transfer of beads or other particulate matter from a source containing a plurality of beads or other particulate matter to a receptacle for the same.



The invention will now be described by way of example only with reference to the following drawings:

Fig 1 shows a cross section through a device of the invention in a first position

5 Fig 2 shows a cross section of a device of the invention in a third position

Fig 3 shows a longitudinal section through a device of the invention

Fig 4 shows an enlarged section through a cavity of a device of the invention.

10 Fig. 5 shows schematically a cross section through the body of a device of the invention having multiple bead receiving cavities.

Referring to Figs 1, 2 and 3 a device according to the invention comprises a body 1 in the form of a frusto-conoidal body of low friction plastics material. In a circumferential surface of the body 1 is a bead receiving cavity 2, of cylindrical shape with its axis aligned radially of the body, ca. 400 microns deep and ca. 400  
15 microns across. The cavity 2 has an opening 3 in the surface of body 1. Note that in Figs. 1, 2 and 3 the size of the cavity 2 is greatly exaggerated, the diameter of the body being ca. 1.5 cm.

The body 1 is situated within a casing 4, of internal shape and size closely corresponding to the outer shape and size of body 1, and within which the body 1  
20 can rotate, the respective inner and outer surfaces of the casing 4 and body 1 thereby sliding across each other in contact.

In the casing 4 is provided a bead entry conduit 5 which terminates in an orifice 6 bounded by a lip 7. The bead entry conduit 5 is in communication with a reservoir 8 (shown schematically) of beads 9 slurried in a liquid vehicle 10. Beads  
25 9 are typically 250-300 micron diameter polystyrene beads and are slurried in a methanol vehicle.

The bead entry conduit 5 is capable of allowing beads 9 to pass along its length towards the body 1.

In Fig. 1 the cavity 2 and the bead entry conduit 5 are shown in  
30 communication via orifice 6, and beads 9 have entered the cavity 2. As shown in Fig. 4 the dimensions of the cavity 2 are such that the cavity can only fully contain one bead 9A, and beads 9B in excess of one project for at least one third of their

diameter. Beads 9 are directed into the cavity 2 by means of gravity, the conduit 5 being above the cavity 2, and also by means of reduced pressure applied via reduced pressure application line 11 and channel 12 aligned axially to body 1 to a small conduit 13 in a lower part of the cavity 2. The small conduit 13 is of too small diameter to allow a bead 9 to pass through it being ca 175 microns in diameter. The small conduit 13 is provided in a small metal insert 14 forming the base of the cavity 2. The use of such a small metal insert 14 facilitates the boring of the small conduit 13 and use of a plastics material body 1, although the entire body 1 and insert 14 could be replaced by an integral construction.

10 As the body 1 is rotated in the direction of the arrow in Fig 1, the cavity moves into a second position 2A shown representatively by dotted lines. In this position the bead entry conduit 5 is closed by the surface of the body 1, and the cavity 2 is also closed by the internal surface of the casing 4.

15 As the body 1 rotates so that the cavity 1 moves into position 2A, as shown in Fig 4 beads 9B in excess of one bead are swept by the lip 7 out of the cavity 2 and are returned to the conduit 5. Also, if beads 9B are stuck to the bead 9A such beads 9B are detached from bead 9A and returned to the conduit 5. In this way only one bead 9A is retained in cavity 2.

20 As body 1 rotates further in casing 4 it moves into a third position as shown in Fig 2 in which cavity 2 is brought into communication with a bead exit conduit 15, also passing through casing 4. At the same time channel 12 is brought into communication with a pressurised air line 16, down which air at ca 15-20 psi is applied, such an air pressure being found suitable to eject the bead 9A without excessive velocity. This air pressure is directed into cavity 2 via the small conduit 25 13, and drives the bead 9A out of the cavity 2 along conduit 15. Body 1 is held in this third position for the short time necessary for the bead 9A to leave the cavity 2 and enter the conduit 15. Conduit 15 is ca 500 microns in diameter to provide clearance for the beads 9 and is typically at least 6 mm long to direct the bead 9 into substantially linear travel so as to avoid loss of the bead. As the bead 9A exits the 30 conduit 15 it may be received by a receptacle 17, shown in Fig 2 as a well of defined location in a microtitre plate 18. The air applied in this way also serves to evaporate and/or disperse methanol vehicle 10.

As the body 1 continues to rotate in the direction shown by the arrow, the cavity 2 moves into a fourth position 2B in which the channel 12 is out of communication with the air line 16, and the cavity 2B is closed by the inner surface of the casing 4.

5 As the body 1 continues to rotate, it is returned to the first position shown in Fig 1, in which it is stopped for the time necessary for the above-described passage of the beads 9 into the cavity 2, and the process is repeated by continued rotation of the body 1. During this time the plate 18 may be moved in an X-Y direction so as to move an empty well 17 into position under the bead exit conduit 15.

10 Referring to Fig. 5, parts of common construction and/or function with Figs. 1 to 4 are numbered correspondingly. The body 1 of the device is shown schematically in cross section. The body 1 is in the form of a cylindrical body of low friction plastics material. In a circumferential surface of the body 1 are four bead receiving cavities 2, of similar construction to that of Fig. 1. Internally the  
15 body 1 includes small conduits 13 communicating with cavities 2, and an axial channel 12. The channel 12 branches into separate channels 19 which can be brought into communication with respective reduced pressure application lines 11 (not shown) and pressurised air lines 16 (not shown) in a casing 4 (not shown) in a similar manner to Figs. 1 to 4. Rotation of the body 1 in the direction of the arrow  
20 within a casing 4 (not shown) of similar construction to that shown in Figs. 1 to 4 above brings each of the cavities 1 sequentially into communication with the bead entry conduit 5 (not shown) and bead exit conduit 15 (not shown) of the casing 4 (not shown) as described above. Similarly the channels 19 are sequentially brought into communication with the reduced pressure application lines 11 (not shown) and  
25 pressurised air lines 16 (not shown) as described above.

**Claims:**

1. A device for transferring beads from a source containing a plurality of beads to a receptacle for beads comprising:

5 a body having a bead receiving cavity in its surface, the cavity having an opening at a surface of the body, the cavity being of dimensions such that it can only fully contain one bead, beads in excess of one projecting for at least one third of their diameter above the surface,

10 a bead entry conduit in communication with, or capable of being brought into communication with, the source and capable of allowing beads to pass along the bead entry conduit towards the body, the bead entry conduit terminating in an orifice bounded by a lip,

15 the opening and the orifice being relatively moveable into communication with each other to allow beads to pass from the bead entry conduit into the cavity, and being thereafter relatively moveable out of communication, the surface of the body and the lip being in moveable contact with each other such that when the opening and the orifice move out of communication with each other beads in the cavity in excess of one bead are removed from the cavity and the bead entry conduit is closed by the surface of the body,

20 a bead exit conduit in communication with, or capable of being brought into communication with, a receptacle for the beads,

the opening and the bead exit conduit being relatively moveable into communication with each other to allow a bead contained in the cavity to pass from the cavity into the bead exit conduit,

25 means to direct one or more beads from the bead entry conduit into the cavity, and

means to direct a bead from the cavity into the bead exit conduit.

2. A device according to claim 1 characterised in that the body is a circular section body, and the bead entry conduit and bead exit conduit are provided in a  
30 correspondingly circular-section casing within which the body closely fits, and

within which the body can rotate, the body surface thereby sliding across the internal surface of the casing.

3. A device according to claim 1 or claim 2 characterised in that the bead  
5 receiving cavity is of dimensions such that at least half of the diameter of beads in excess of one in the cavity projects above the body surface.
4. A device according to any one of the preceding claims characterised in that  
10 the surface of the body and the lip are in slideably moveable contact with each other, and the lip and opening can thereby move relative to each other in a direction perpendicular to the depth of the cavity, and the lip thereby moves across the opening to sweep beads in excess of one from the cavity back into the bead entry conduit.
- 15 5. A device according to any one of claims 2 to 4 characterised in that the bead entry conduit is provided in a circular-sectional casing, this conduit is a passage through the casing, terminating in an orifice opening in the internal surface of the casing, the internal surfaces of the edge of the orifice forming the lip, and rotation  
20 of the body within the casing provides the above-described slideably moveable contact.
6. A device according to any one of claims 2 to 5 characterised in that the body  
is a circular section body and the bead entry conduit and bead exit conduit are  
provided in a circular sectional casing, and the cavity opening and the bead entry  
25 conduit and bead exit conduit are brought into and out of communication by rotation of the body within the casing.
7. A device according to any one of the preceding claims characterised in that  
the means to direct one or more beads from the bead entry conduit into the cavity  
30 comprises the application of reduced pressure to the cavity to suck beads into the cavity and the means to direct a bead from the cavity into the bead exit conduit comprises a driving fluid directed into the cavity to drive a bead out of the cavity.

8. A device according to any one of claims 1 to 7 characterised in that the body is moveable into a first position such that the orifice and opening are in communication to allow beads to enter the cavity, then the body is then further  
5 moveable into a second position so that the opening and orifice are out of communication, and as this takes place beads in excess of one are removed from the cavity, the body is then moveable into a third position such that the opening and the bead exit conduit are in communication with each other to allow a bead to exit the cavity and pass into the bead exit conduit, then the body is moveable into a fourth  
10 position so that the opening and bead exit conduit are out of communication, and the procedure is then repeated so as to return the body into the said first position.

9. A device according to claim 8 characterised in that the body is a circular section body and the said movements are achieved by the said first, second, third  
15 and fourth positions being located sequentially circumferentially on a rotation cycle.

10. Use of a device according to any one of preceding claims 1 to 9 in a process for the transfer of beads or other particulate matter from a source containing a plurality of beads or other particulate matter to a receptacle for the same.

1/2

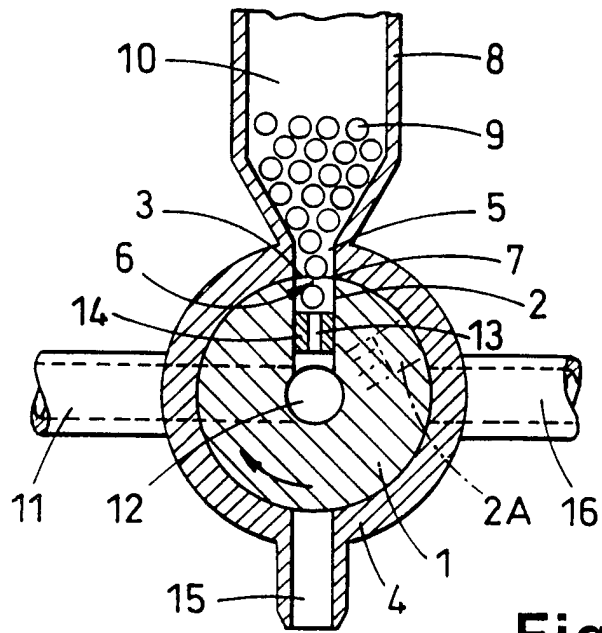

Fig. 1

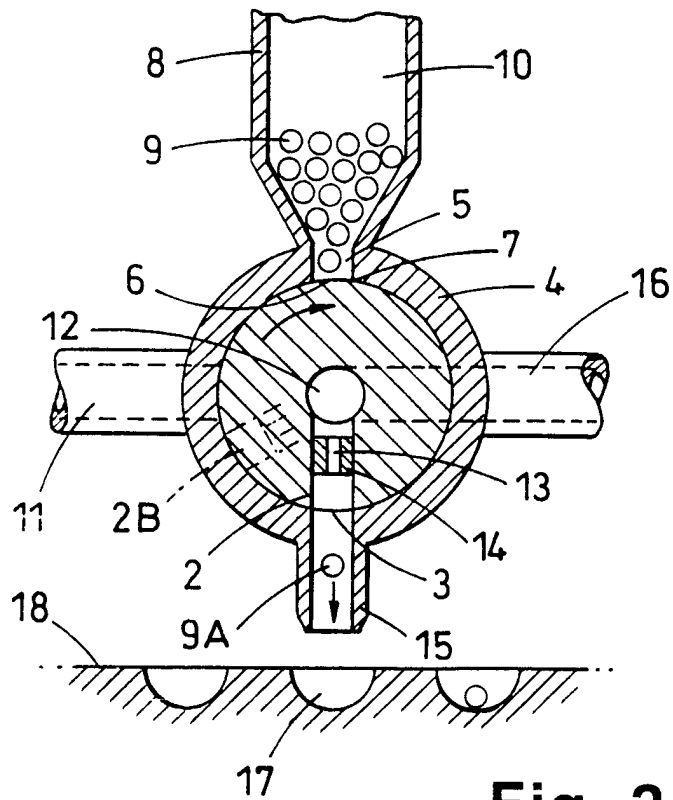
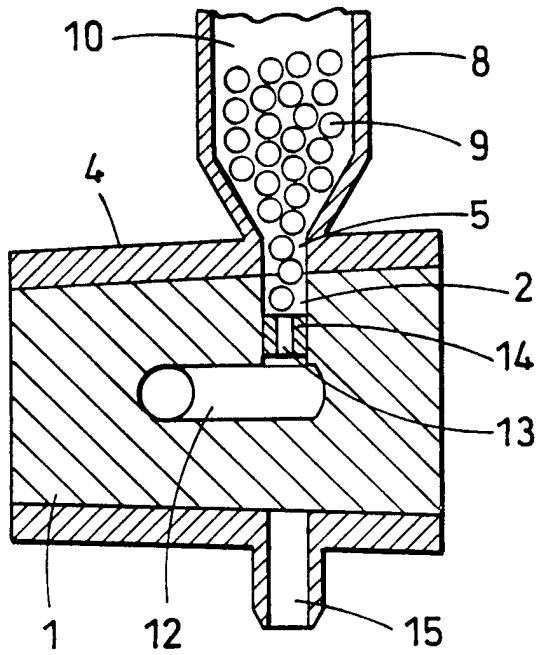
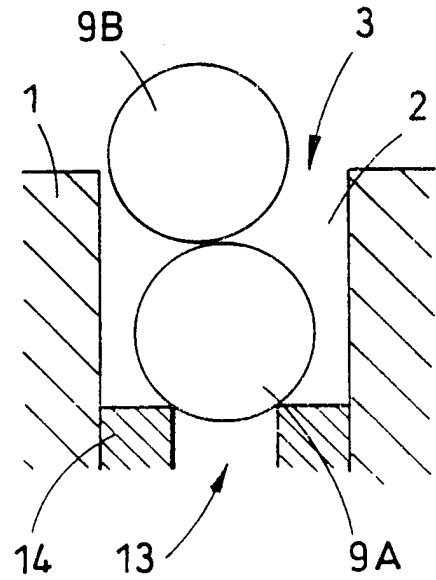

Fig. 2



**Fig. 3**



**Fig. 4**

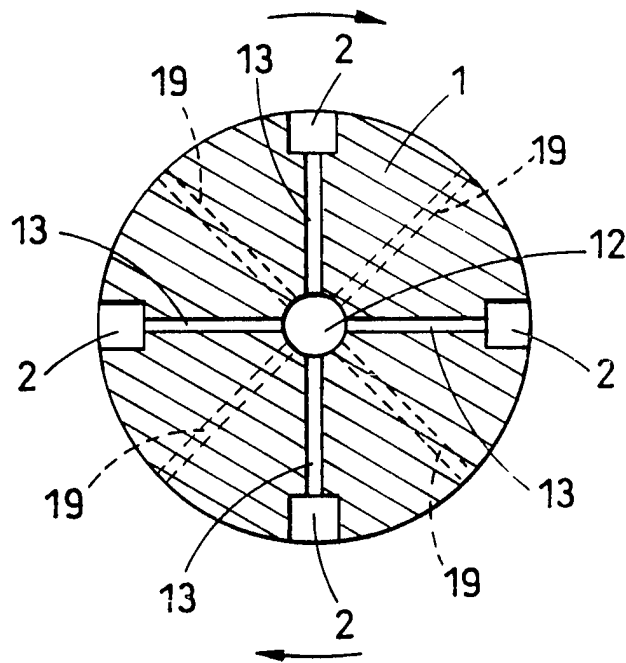

**Fig. 5**



# INTERNATIONAL SEARCH REPORT

International Application No  
PCT/EP 97/06948

**A. CLASSIFICATION OF SUBJECT MATTER**  
 IPC 6 B01L11/00 B65G47/14 G01N35/10 //C12Q1/02,C12Q1/04

According to International Patent Classification (IPC) or to both national classification and IPC

**B. FIELDS SEARCHED**

Minimum documentation searched (classification system followed by classification symbols)  
 IPC 6 B01L B65G B07B B01J G01N

Documentation searched other than minimum documentation to the extent that such documents are included in the fields searched

Electronic data base consulted during the international search (name of data base and, where practical, search terms used)

**C. DOCUMENTS CONSIDERED TO BE RELEVANT**

Category °	Citation of document, with indication, where appropriate, of the relevant passages	Relevant to claim No.
P,X	US 5 616 299 A (WALKER DAVID W ET AL) 1 April 1997 see column 1, line 62 - column 2, line 41 see column 2, line 58 - column 3, line 40 see column 4, line 11 - column 5, line 67; figures 1-5	1-6,8,9
A	----- WO 94 28119 A (SMITHKLINE BEECHAM PLC ;MACMICHAEL DONALD BRUCE (GB); DRAKE DAVID) 8 December 1994 cited in the application see page 1, line 19 - page 1, line 37 see page 4, line 10 - page 4, line 12 see page 4, line 24 - page 4, line 38 see page 6, line 7 - page 7, line 18 see page 13, line 24 - page 16, line 4 see page 17, line 36 - page 18, line 24 see figures 1-3 ----- -/--	1-10

Further documents are listed in the continuation of box C.       Patent family members are listed in annex.

° Special categories of cited documents :

"A" document defining the general state of the art which is not considered to be of particular relevance "E" earlier document but published on or after the international filing date "L" document which may throw doubts on priority claim(s) or which is cited to establish the publication date of another citation or other special reason (as specified) "O" document referring to an oral disclosure, use, exhibition or other means "P" document published prior to the international filing date but later than the priority date claimed	"T" later document published after the international filing date or priority date and not in conflict with the application but cited to understand the principle or theory underlying the invention "X" document of particular relevance; the claimed invention cannot be considered novel or cannot be considered to involve an inventive step when the document is taken alone "Y" document of particular relevance; the claimed invention cannot be considered to involve an inventive step when the document is combined with one or more other such documents, such combination being obvious to a person skilled in the art. "&" document member of the same patent family
---	---

Date of the actual completion of the international search	Date of mailing of the international search report
2 April 1998	14/04/1998

Name and mailing address of the ISA European Patent Office, P.B. 5818 Patentlaan 2 NL - 2280 HV Rijswijk Tel. (+31-70) 340-2040, Tx. 31 651 epo nl, Fax: (+31-70) 340-3016	Authorized officer  Koch, A
--	-----------------------------------

INTERNATIONAL SEARCH REPORT

International Application No  
PCT/EP 97/06948

C.(Continuation) DOCUMENTS CONSIDERED TO BE RELEVANT		
Category	Citation of document, with indication, where appropriate, of the relevant passages	Relevant to claim No.
A	<p>WO 91 06496 A (AUTOTROL CORP) 16 May 1991                      see page 1, line 2 - page 1, line 9                      see page 2, line 20 - page 3, line 22                      see page 4, line 18 - page 4, line 27                      see page 4, line 37 - page 6, line 34                      see figures 1-7</p> <p style="text-align: center;">----</p>	1-9
A	<p>US 4 000 927 A (SAKAMOTO MASAKATSU ET AL)                      4 January 1977                      see column 2, line 13 - column 2, line 34                      see column 4, line 16 - column 4, line 52                      see column 5, line 10 - column 5, line 42                      see column 7, line 30 - column 8, line 35                      see column 8, line 48 - column 9, line 1                      see column 9, line 31 - column 10, line 16                      see figures 14-20</p> <p style="text-align: center;">-----</p>	1-10

# INTERNATIONAL SEARCH REPORT

information on patent family members

International Application No

PCT/EP 97/06948

Patent document cited in search report	Publication date	Patent family member(s)	Publication date
US 5616299 A	01-04-97	NONE	
WO 9428119 A	08-12-94	AU 6844694 A EP 0700434 A JP 8510380 T	20-12-94 13-03-96 05-11-96
WO 9106496 A	16-05-91	US 5014877 A AU 6621890 A	14-05-91 31-05-91
US 4000927 A	04-01-77	NONE	