

(No Model.)

2 Sheets—Sheet 1.

J. MURDIE. COMBINED LOCK AND LATCH.

No. 526,456.

Patented Sept. 25, 1894.

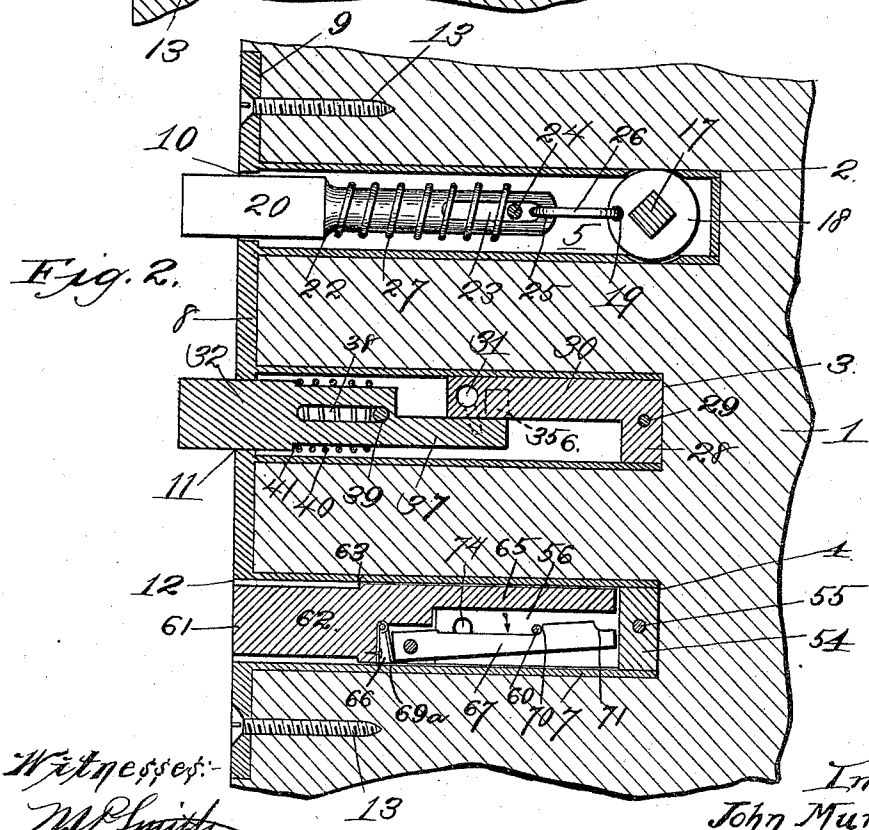
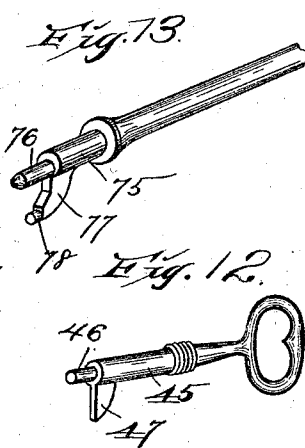
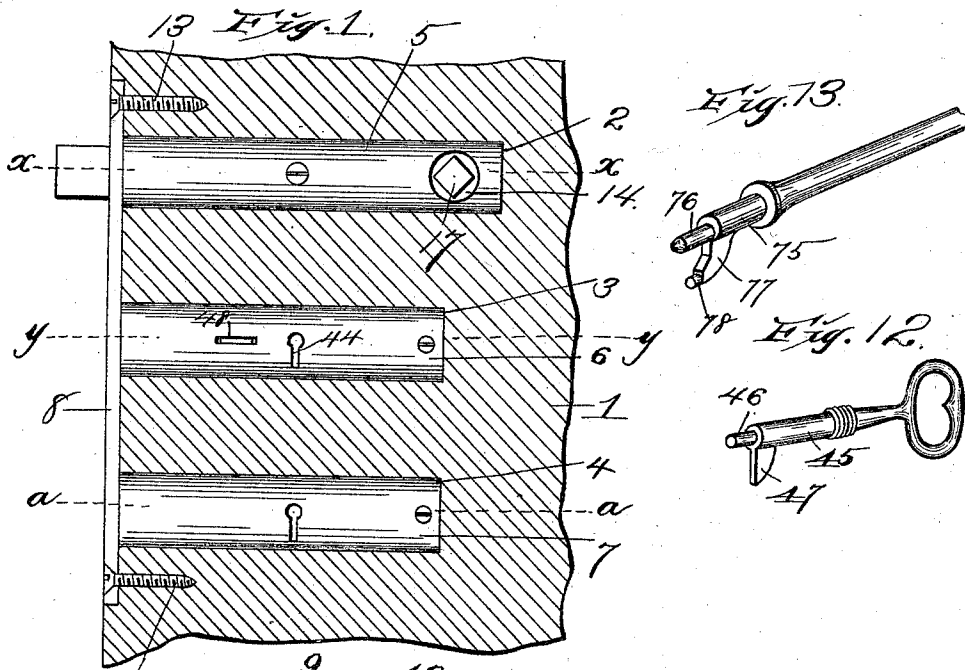

Witnesses:
M. Smith
A. Hooper

Inventor:
 John Murdie

By *Hudson & Kiplan*
 Attys.

(No Model.)

2 Sheets—Sheet 2.

J. MURDIE. COMBINED LOCK AND LATCH.

No. 526,456.

Patented Sept. 25, 1894.

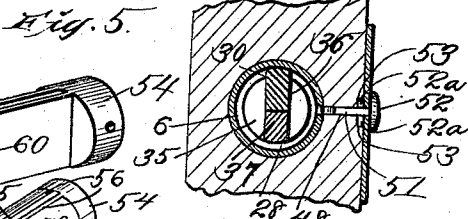
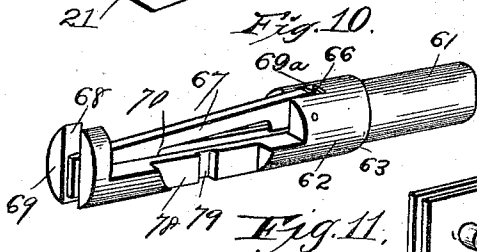
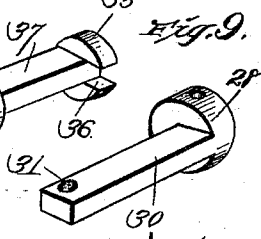
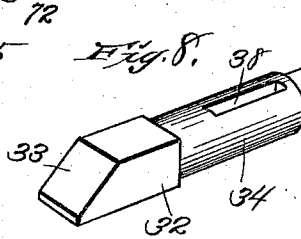
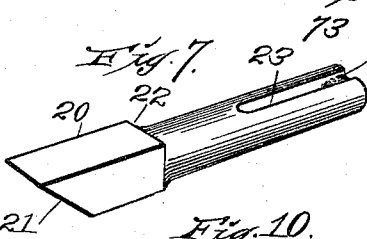
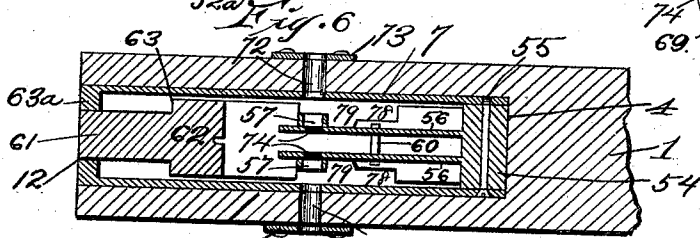
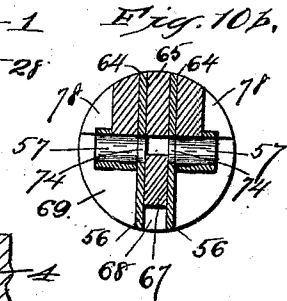
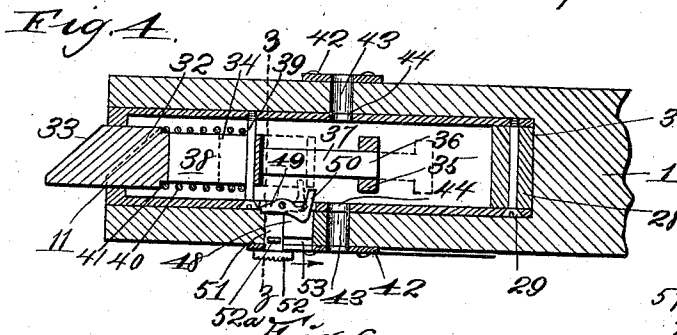
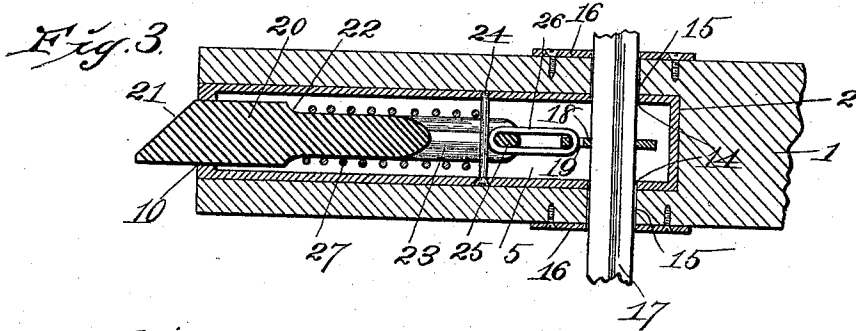

Witnesses:
M.P. Smith.

[Handwritten signature]

Inventor:
John Murdie.

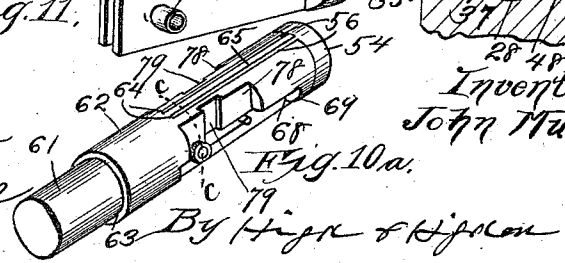

By Higgin & Higgin

UNITED STATES PATENT OFFICE.

JOHN MURDIE, OF NORTH TOPEKA, KANSAS.

COMBINED LOCK AND LATCH.

SPECIFICATION forming part of Letters Patent No. 526,456, dated September 25, 1894.

Application filed February 20, 1894. Serial No. 500,843. (No model.)

To all whom it may concern:

Be it known that I, JOHN MURDIE, of North Topeka, Shawnee county, Kansas, have invented certain new and useful Improvements in a Combined Lock and Latch, of which the following is a full, clear, and exact description, reference being had to the accompanying drawings, forming a part hereof.

My invention relates to combined locks and latches.

The object of my invention is to produce a fastening appliance, consisting of a day-latch, night-latch and locking-bolt each surrounded by a barrel or cylinder; these barrels or cylinders being connected by an end plate, which may be secured in position without the necessity of mortising deep the edge of the door, recesses only being bored to receive the barrels of the latches and bolt, thereby making it possible to secure the appliance in position in a much shorter time and at less cost than with locks of the usual construction; furthermore to produce a locking appliance, which is simple, strong, durable, and inexpensive of construction.

To the above purposes, my invention consists in certain peculiar and novel features of construction and combinations of parts, as will be hereinafter described and claimed.

In order that my invention may be fully understood, I will proceed to describe it with reference to the accompanying drawings, in which—

Figure 1, is a vertical sectional view of a portion of the door, and showing a combined lock and latch constructed in accordance with my invention therein. Fig. 2, is a central vertical sectional view of the same, and showing the day-latch in elevation. Fig. 3, is a sectional view taken on the line $x-x$ of Fig. 1. Fig. 4, is a sectional view taken on the line $y-y$ of Fig. 1, and Fig. 5, is a cross sectional view taken on the line $z-z$ of Fig. 4. Fig. 6, is a sectional view taken on the line $a-a$ of Fig. 1. Fig. 7, is a detail perspective view of the day-latch. Fig. 8, is a detail perspective view of the night-latch, and Fig. 9, is a detail perspective view of a guide bar upon which said night-latch is adapted to operate. Fig. 10, is a detail perspective view of the locking-bolt. Fig. 10^a, is a perspective view of the locking bolt mechanism, detached from the

barrel or cylinder. Fig. 10^b, is a vertical sectional view taken on the line $c-c$ of Fig. 10^a. Fig. 11, is a detail perspective view of the guide for the locking bolt. Fig. 12, is a detail perspective view of the key used in connection with the night-latch. Fig. 13, is a detail perspective view of a portion of a key used in connection with the locking-bolt.

Referring to the drawings, 1 designates a portion of the door, into the front edge of which are bored the cylindrical recesses 2, 3 and 4; the recess 2 being adapted to receive a barrel or cylinder 5, the recess 3 to receive a barrel or cylinder 6 and the recess 4 to receive a barrel or cylinder 7, and these barrels or cylinders are united or connected at their outer ends by the vertical plate 8, which is adapted to fit in a shallow recess 9 chiseled in the edge of the door, and this vertical plate 8 is formed with an opening or hole 10 communicating with the front and open end of the barrel or cylinder 5, with a hole or opening 11 communicating with the open end of the barrel or cylinder 6, and with a hole or opening 12 communicating with the barrel or cylinder 7, and is also secured firmly in position by screws 13 which enter the edge of the door.

Formed through the barrel or cylinder 5 near its rear end and in horizontal alignment with each other are the holes or apertures 14, and these holes or apertures communicate with registering holes or passages 15 formed through the door, and with registering holes or apertures formed through the escutcheon plates 16 which are secured by screws or other suitable means to opposite sides of the door, and extending horizontally through these aligned holes or passages is the rectangular shaft 17, which is adapted to carry upon each end a door knob of the usual or any preferred construction. Secured rigidly upon said squared shaft, and about centrally the width of the barrel or cylinder 5, is a circular plate or disk 18, and this disk is formed near one edge with a circular hole or aperture 19.

The bolt 20 is formed in the usual manner at its outer end with the beveled or inclined surface 21 and has its stem of reduced diameter and cylindrical form, extending longitudinally inward of the barrel or cylinder, and by thus reducing the diameter of the

stem an annular shoulder 22 is formed at the junction of said stem with the body-portion of the bolt. A longitudinally extending and horizontal slot 23 is formed in the rear portion of the stem, through which passes a screw bolt 24, the opposite ends of which engage in the walls of the barrel or cylinder. The bridge-portion 25 formed at the inner end of said slot is preferably reduced in thickness, is rounded at its inner end, so as to be more snugly engaged by a link 26, the opposite end of said link engaging loosely the hole or aperture of the disk 18 carried by the knob-shaft. Spirally encircling the cylindrical stem of said bolt and bearing in its opposite ends against the shoulder 22 and the cross bolt 24, is a spring 27, the tendency of which is to hold the bolt in its advanced position, or with the beveled end thereof projecting beyond the edge of the door. It will now be seen that by grasping either knob and turning the same, the disk 18 is rotated, and this disk being pivotally connected moves the bolt inward, and compresses the spring 27. Immediately the knob is released the spring 27 expands and again forces the bolt forward to its original position, as will be clearly seen.

Referring now to the night-latch construction, 28 designates a circular block or disk which closes the inner end of the barrel or cylinder 6, and is secured in such position by a cross bolt 29. This circular block or disk is formed at its upper side and about midway its width, with the forwardly or outwardly projecting horizontal arm 30, through the outer end of which the horizontal aperture or hole 31 is formed; this aperture or hole being adapted to receive the end of the night-latch key as hereinafter referred to. The body-portion 32 of the latch is formed with the beveled outer end 33 in the usual manner, and extending inwardly and of reduced diameter from said body-portion is the cylinder stem 34. The circular flange 35 is formed at the extreme inner end of said latch, and is provided with a rectangular notch 36 in its upper edge which embraces the rectangular arm 30 of the disk 28, and the circular flange 35 is united to the inner end of the cylinder stem 34 by a rectangular arm 37, which bears at its upper edge against the under side of the arm 30 of the disk 28. The cylindrical stem 34 is also formed with a longitudinally extending and horizontal slot 38, through which extends a bolt 39 which is secured at its opposite ends in the walls of the barrel or cylinder 6. A spring 40 spirally encircles said stem and bears at its opposite ends against the bolt 39 and the annular shoulder 41 formed at the junction of the body-portion 32 and the stem 34 of the bolt, the tendency of said spring being to hold the bolt in its advanced position.

Formed horizontally through the door in alignment with the hole or aperture 31 of the arm 30 and also with holes or apertures in

the escutcheon plates 42 secured to opposite sides of said door are key-hole passages 43, and these passages are also aligned or register with similar holes or passages 44 in the walls of the barrel or cylinder 6. In order to retract the bolt when desired or necessary the barrel-portion 45 of the key is inserted through one or the other of these sets of aligned apertures, so that the inner end thereof shall bear against the arm 30 of the disk 28, and the reduced cylindrical stem 46 of said key shall enter the aperture 31, and the arm 47, projecting outwardly from the barrel-portion of the key, shall bear against the side of the arm 37, and adjacent to the flange 35 as is shown in dotted lines Fig. 2. By now operating the key so that the arm thereof shall bear against said flange, the resistance of the spring 40 may be overcome and the bolt retracted when the door may be operated. Immediately the key is released or withdrawn from the lock the spring again forces the bolt outward to its original position. In order to provide means so that the night-latch shall be held in its retracted position during the day, or when it is desired that the door shall be unlocked, I form a longitudinal slot 48 which extends inward through the door, the escutcheon plate, and through the inner side or wall of the barrel or cylinder, and pivoted in the inner end of said slot is a cam-latch 49, from one end of which projects inwardly an arm 50. A slide latch 51 extends through the slot and bears at its inner end against the cam-latch, and this slide latch is formed at its outer end with a serrated or roughened head 52, at the outer side of the escutcheon plate, and in order to prevent said slide-latch from being withdrawn from the slot, I form a pair of grooves 53 connecting with the outer longitudinal margin of the slot 48, in which engage lugs 52^a projecting from the upper and lower sides of the slide latch 51. It will be seen from this construction, that when the slide latch is in its advanced or outward position as shown in Fig. 4, the latch bolt may be operated as desired, and when said night-latch is withdrawn, by moving the slide latch in the direction of the arrow Fig. 4, the arm 50 of the cam latch can be moved inwardly to engage the slot 38 of the stem and bear against the rear and inner end thereof, thus locking the latch in its retracted position. By moving the slide-latch to its original position as shown in full lines same figure, the bolt is free to move in either direction.

Referring now to the construction of the locking bolt-mechanism, 54 designates a circular block or disk which is secured by cross bolt 55 to close the rear or inner end of the cylinder 7, and extending longitudinally inward therefrom is a pair of vertical flanges 56—56, these flanges being parallel and adjacent to each other. Projecting horizontally outward from the outer sides of said parallel arms 56 are the annular flanges 57, these

flanges being adapted to receive the end of the key, as hereinafter referred to. Connecting the arms 56 and in longitudinal alignment with the key-flanges 57 is a cylindrical stud or pin 60. The bolt proper, 61, is formed with a cylindrical body-portion 62, which is of increased diameter so as to form an annular shoulder 63 at the junction therewith of the bolt proper, and this shoulder is adapted to limit the outward movement of the bolt by coming in contact with the annular flange 63^a, marginally surrounding the opening 12 in the outer or open end of the barrel or cylinder. This body-portion is formed with a pair of longitudinally extending parallel recesses 64 which are engaged by the parallel arms 56, and the tongue 65 between said recesses engages the recess or space between said parallel arms 56; said arms thus forming a guide for the longitudinal movement of the bolt. The tongue 65, however, is only about one-third the depth or thickness of the plates or arms 56, and pivoted in the recess 66 beneath that portion of the tongue where it joins the body-portion 62 of the bolt, is a lever 67, said lever extending longitudinally outward and having its outer ends fitting in the vertical recess 68 formed in the circular flange or disk 69 at the inner end of the body-portion of the bolt. Bearing at the pivotal end of said lever below the pivotal point thereof is a spring 69^a, this spring being secured in any suitable manner in the recess 66. The tendency of this spring is to throw the lever upward and inward as shown more clearly in Fig. 2, and so that the shoulder 70 formed by recessing the upper edge of the lever would bear against the cross-pin 60 uniting the parallel plates or arms 56. A shoulder 71 is also formed near the free end of said lever by recessing the upper edge thereof, and the object of this shoulder will be presently explained.

Horizontal passages 72 are formed through the door and also through the sides of the barrel or cylinder 7 and are arranged in horizontal alignment with and opposite to key-hole flanges 57 of the parallel plates or arms 56, and these passages 72 also register with the similar passages formed in the escutcheon plates 73 secured in the usual manner to the opposite sides of the door.

When the locking bolt is retracted, the spring-actuated lever has its shoulder 70 engaging against the rear or inner side of the pin 60, and thereby prevents the bolt being operated, and when this lever is in such position the upper margin thereof projects beyond the inner and lower margins of the circular openings 74 formed through the parallel plates or arms 56, and which connect with the circular flanges 57. To operate the latch to its locking position, the lever 67 must be moved downwardly, and in order to accomplish this I provide a key of peculiar construction which I will proceed to describe. 75 designates the barrel portion of this key

from one end of which a reduced cylindrical portion 76 projects, and the end of this portion 76 is rounded or formed conical as shown in Fig. 13. Projecting outwardly from one side of the barrel-portion is an arm 77, and the lower end of this arm is formed with a reduced cylindrical projection 78. In order to allow this key to be operatively introduced to the lock, it is necessary to recess or cut away the body portion of the bolt at each side as shown at 78, these recesses extending for a suitable distance and formed in said recess portions are the vertical recesses 79, which are adapted when the bolt is in its extended or retracted position to be outward or inward of the circular flanges 57 respectively of the parallel plates 56. Now when it is desired to advance the bolt from its retracted position, as shown in Fig. 2, the key is passed through one of the passages 72 and circular flanges 57 until the rounded or conical end thereof shall come in contact with the upper edge of the lever 67. When this takes place, the lever will be forced downwardly in the direction of the arrow Fig. 2, so that the shoulder 70 will be disengaged from the cross pin 60. By now turning the key upwardly and to the left, the cylindrical projection 78 thereof will enter and bear against the left margin of the recess 79 and force the bolt outward as will be clearly seen, and when the bolt reaches its extended position the spring 69 bearing against the lever below its pivotal point forces its free end upward so that the shoulder 71 shall bear against the outer side of the cross pin 60, and thus lock the bolt in its advanced position. When it is desired to retract the bolt, the key is inserted as before so that its rounded end shall move the lever downward and the shoulder 71 shall be disengaged from the cross pin. The key is now turned to the right until the projection 78 comes in contact with the right hand margin of the recess 79 when the bolt will be forced inwardly, and held in such position by the spring forcing the lever to cause the shoulder 70 to again engage the cross pin 60.

From the above description, it will be seen that I have produced a combined latch and lock which is simple, strong, durable and comparatively inexpensive of construction, and which can be fitted to a door in much less time than the locks of the ordinary construction, and a lock which is also positive and reliable in operation.

Having thus described my invention, what I claim as new, and desire to secure by Letters Patent, is—

1. A combined lock and latch, comprising a cylindrical casing or barrel, a guide arm projecting from its rear end, a spring-actuated bolt in said casing, and having an arm and a notched plate at the inner end of said arm engaging the said guide arm, and means to retract said spring-actuated latch, substantially as set forth.

2. A combined lock and latch, comprising a

- barrel or casing, a block or disk closing the inner end of said casing and having a guide arm, a bolt in said casing having a slotted stem and an annular shoulder at the outer end of said stem, and a cross bolt passing through said slot and a spring bearing against the cross bolt and the annular shoulder, and an arm extending rearwardly from the stem and a notched plate at the inner end of said arm engaging the guide arm, and a shoulder formed at the junction of the stem and the arm against which the key is adapted to bear to retract the latch, substantially as set forth.
3. A combined lock and latch, comprising a barrel or casing, a spring-actuated latch having a slotted stem within said casing, a cam-latch pivoted to said casing and having an arm adapted to engage said slot and a slide latch adapted to operate said cam-latch so that it shall engage said slot or be disengaged from said slot, substantially as and for the purpose set forth.
4. A combined lock and latch, comprising a barrel or cylinder, having an opening at one end and a shoulder surrounding said opening, a circular block or disk closing its inner or rear end, and parallel guide arms or plates projecting from said block or disk, a bolt having a shoulder adapted to engage the first-mentioned shoulder, and having grooves and a central tongue, said grooves engaged by the parallel plates of the disk or block, and said tongue engaging the space between said parallel plates or arms of the disk or block, openings formed through said plates or arms, a lever pivoted in a recess in the lock and ex-

tending between said plates or arms, a spring bearing against said lever below its pivotal point, shoulders formed in said lever, and a cross pin carried by said plates or arms and engaged by one or the other of said shoulders, substantially as set forth.

5. A combined lock and latch, comprising a cylindrical casing or barrel having an open end, a block or disk closing the opposite end of said casing and having parallel arms or plates, a cross pin carried by said arms or plates and key-hole openings formed through said arms or plates, and key hole passages formed through the door and casing or barrel in alignment with the key hole openings of the parallel arms or plates, a bolt located within said casing and having a tongue fitting between said parallel arms or plates and recesses engaged by said arms or plates and recessed in its sides, and a spring-actuated lever having shoulders, carried by said bolt, and located between said arms or plates, in combination with a key having a rounded or pointed end adapted to be passed through said openings, to pivotally operate the lever, and a projection upon said key adapted to engage shoulders at each side of the recesses formed in said bolt, so that said bolt may be advanced or contracted, substantially as set forth.

In testimony whereof I affix my signature in presence of two witnesses.

JOHN MURDIE.

Witnesses:

M. R. REMLEY,
S. V. SCHINDLER.