

(19) World Intellectual Property Organization
International Bureau



(43) International Publication Date
7 February 2008 (07.02.2008)

PCT

(10) International Publication Number
WO 2008/016905 A1

(51) International Patent Classification:
G03B 21/00 (2006.01)

(21) International Application Number:
PCT/US2007/074825

(22) International Filing Date: 31 July 2007 (31.07.2007)

(25) Filing Language: English

(26) Publication Language: English

(30) Priority Data:

60/820,894	31 July 2006 (31.07.2006)	US
60/820,887	31 July 2006 (31.07.2006)	US
60/820,888	31 July 2006 (31.07.2006)	US
60/820,883	31 July 2006 (31.07.2006)	US
60/821,032	1 August 2006 (01.08.2006)	US
60/838,988	21 August 2006 (21.08.2006)	US
11/772,609	2 July 2007 (02.07.2007)	US

(81) Designated States (unless otherwise indicated, for every kind of national protection available): AE, AG, AL, AM, AT, AU, AZ, BA, BB, BG, BH, BR, BW, BY, BZ, CA, CH, CN, CO, CR, CU, CZ, DE, DK, DM, DO, DZ, EC, EE, EG, ES, FI, GB, GD, GE, GH, GM, GT, HN, HR, HU, ID, IL, IN, IS, JP, KE, KG, KM, KN, KP, KR, KZ, LA, LC, LK, LR, LS, LT, LU, LY, MA, MD, ME, MG, MK, MN, MW, MX, MY, MZ, NA, NG, NI, NO, NZ, OM, PG, PH, PL, PT, RO, RS, RU, SC, SD, SE, SG, SK, SL, SM, SV, SY, TJ, TM, TN, TR, TT, TZ, UA, UG, US, UZ, VC, VN, ZA, ZM, ZW.

(84) Designated States (unless otherwise indicated, for every kind of regional protection available): ARIPO (BW, GH, GM, KE, LS, MW, MZ, NA, SD, SL, SZ, TZ, UG, ZM, ZW), Eurasian (AM, AZ, BY, KG, KZ, MD, RU, TJ, TM), European (AT, BE, BG, CH, CY, CZ, DE, DK, EE, ES, FI, FR, GB, GR, HU, IE, IS, IT, LT, LU, LV, MC, MT, NL, PL, PT, RO, SE, SI, SK, TR), OAPI (BF, BJ, CF, CG, CI, CM, GA, GN, GQ, GW, ML, MR, NE, SN, TD, TG).

(71) Applicant (for all designated States except US): **3M INNOVATIVE PROPERTIES COMPANY** [US/US]; 3M Center, Post Office Box 33427, Saint Paul, Minnesota 55133-3427 (US).

(72) Inventor: **GRACE, Jennifer L.**; 3M Center, Post Office Box 33427, Saint Paul, Minnesota 55133-3427 (US).

(74) Agents: **PRALLE, Jay R.**, et al.; 3M Center, Office of Intellectual Property Counsel, Post Office Box 33427, Saint Paul, Minnesota 55133-3427 (US).

Declarations under Rule 4.17:

- as to applicant's entitlement to apply for and be granted a patent (Rule 4.17(ii))
- as to the applicant's entitlement to claim the priority of the earlier application (Rule 4.17(iii))

Published:

- with international search report
- before the expiration of the time limit for amending the claims and to be republished in the event of receipt of amendments

(54) Title: OPTICAL PROJECTION SUBSYSTEM

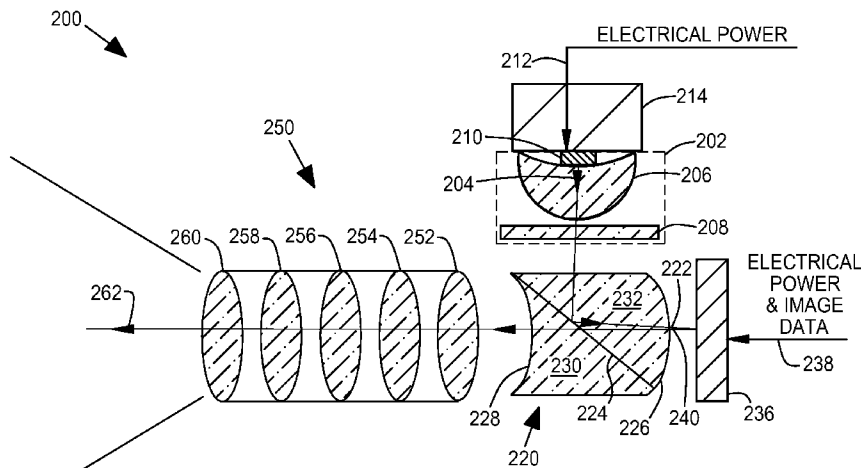

(57) Abstract: A projection subsystem includes a light engine that provides a collection lens, a collimator and at least one solid state light emitter. A projection lens assembly receives the image and provides a projection beam having a luminous flux level. The projection subsystem has a portability efficacy.

WO 2008/016905 A1

OPTICAL PROJECTION SUBSYSTEM

CROSS-REFERENCE TO RELATED APPLICATIONS

The present application is based on and claims the benefit of U.S. provisional
5 patent applications Serial No. 60/820,894, filed July 31, 2006 the content of which is
hereby incorporated by reference in its entirety; Serial No. 60/820,887, filed July 31, 2006
the content of which is hereby incorporated by reference in its entirety; Serial No.
60/820,888, filed July 31, 2006 the content of which is hereby incorporated by reference in
its entirety; Serial No. 60/820,883, filed July 31, 2006 the content of which is hereby
10 incorporated by reference in its entirety; Serial No. 60/821,032, filed August 1, 2006 the
content of which is hereby incorporated by reference in its entirety; Serial No. 60/838,988,
filed August 21, 2006 the content of which is hereby incorporated by reference in its
entirety; and Serial No. 11/772609, filed July 2, 2007 the content of which is hereby
incorporated by reference in its entirety.

15

BACKGROUND

Optical projectors are used to project images onto surfaces for viewing by groups
of people. Optical projectors include optical projector subsystems that include lenses,
20 filters, polarizers, light sources, image forming devices and the like. Fixed front and rear
electronic projectors are known for use in education, home theatres and business meeting
use. Known light sources include black body lamps, gas discharge lamps, and solid state
sources such as lasers, light emitting diodes (LED's) and organic light emitting diodes
(OLED's). Head mounted displays (HMD's) are known for individual use. For mobile
25 applications, there is a desire to miniaturize optical projectors both in terms of volume and
thickness and make them extremely power efficient while maintaining low power
consumption, low cost and high image quality. However, the large dimensions and high
power consumption of existing optical projection subsystems limit efforts to create a truly
portable projector. A method and optical projection subsystem are needed that provide
30 both miniaturization and efficiency to project good quality images in a cost effective
manner.

SUMMARY

Disclosed is a projection subsystem. The projection subsystem comprises an illumination subsystem that provides an incoherent, homogenized light beam. The illumination subsystem includes a collection lens, a collimator and at least one solid state light emitter. The solid state light emitter receives an electrical power level and is couplable to a heat sink.

The projection subsystem includes an image-forming device. The image forming device receives image data and the polarized beam. The image-forming device provides an image to the refractive body.

The projection subsystem comprises a projection lens assembly. The projection lens assembly receives the image from the refractive body and provides an image projection beam having a luminous flux level.

According to one aspect, the projection subsystem has a portability efficacy that comprises a volume of less than 14 cubic centimeters and a thickness of less than 14 millimeters.

BRIEF DESCRIPTION OF THE DRAWINGS

FIG. 1 is a graph 100 that illustrates a qualitative measure of portability efficacy for projection subsystems.

FIG. 2 illustrates a projection subsystem.

FIG. 3A illustrates a projection subsystem that includes an anamorphic optical device.

FIG. 3B illustrates a projection subsystem that includes an anamorphic surface on a refractive body.

FIG. 4 illustrates an oblique view of the projection subsystem of FIG. 3A.

FIGS. 5A, 5B illustrate portions of projection subsystems that include blue blocking filters.

FIGS. 5C, 5D illustrate portions of projection subsystems that include polarization filters that change image contrast.

FIG. 6 illustrates a projection subsystem that has a plate heat sink.

FIG. 7 illustrates a projection subsystem that includes light recycling.

FIG. 8 illustrates a projection subsystem that includes an enclosure.

FIG. 9 illustrates an oblique view of a projection subsystem.

FIG. 10A illustrates a light emitting diode.

FIG. 10B illustrates an image formed from light emitted by the light emitting diode
of FIG. 10A through an optical system.

FIG. 11A, 11B, 11C, 11D illustrate examples of mounting an optical component
in a projection subsystem.

FIGS. 12A, 12B illustrate alternative embodiments of projection subsystems.

10

DETAILED DESCRIPTION

15

For mobile applications it is desirable to project images of diagonal size 12 cm or
more, under ambient lighting conditions, which would generally require at least 3 lumens
flux and at least 30:1 contrast ratio for good viewability. Additional desired features to
provide good image quality can include a large number of resolvable pixels, wide color
gamut, and image uniformity.

20

For mobile applications “portability efficacy” will be defined as a combined
measure of the small size, high power efficiency and luminous output of the projection
subsystem. FIG. 1 is a graph 100 that illustrates two aspects of portability efficacy for
projection subsystems. The term “projection subsystem” refers to a light source, image
forming device and associated refractive or reflective optical components such as lenses,
mirrors, or beam splitters that are used to provide a projected optical image. A vertical axis
102 represents power efficiency of a projection subsystem in lumens for 1 watt of
electrical power applied to the light source. A horizontal axis 104 represents a volume of a
projection subsystem. Portability efficacy 108 increases as the efficiency increases, and
increases as the volume decreases. Projection subsystems have increased portability when
power efficiency is higher and the volume is smaller.

25

30

Desired features for projection subsystems include a high level of optical flux in
the projected image, large screen size, high contrast, large pixel content, and a wide color
gamut. FIG. 1 illustrates one way of comparing some of these features for different optical
systems. As described in the presently disclosed embodiments, projection subsystems with
incoherent light sources are able to provide useful combinations of the desired features.

As illustrated in FIG. 1, representative conventional projection subsystems A, C, D, and E are evaluated for power efficiency and size and mapped onto the graph 100. Subsystems A and C are generally superior to D and E in power efficiency and size, but they use coherent laser light sources that have drawbacks in terms of high cost, low image quality from laser speckle, and potential eye safety issues, particularly under electrical or mechanical fault conditions. Subsystems D and E use incoherent LED light sources, which may overcome the drawbacks of laser-based systems, but they are relatively large, low in power efficiency or both, leading to limited portability efficacy. The exemplary projection subsystem of the present invention is represented on graph 100 as projection subsystem B, which uses an incoherent light source and has smaller size and greater efficiency than subsystems D and E.

Ambient lighting levels in projection environments do not scale down when a projector design is miniaturized or scaled down. A sufficient projection light power level is desired in order to provide a projection image that is bright enough for a group of viewers in the presence of ambient light. If the size of a light emitting source were to be miniaturized, for example, and the same electrical power level were to be applied to the smaller light emitting source, increased temperature rises would be encountered in the smaller light emitting source that could cause overheating. There is a need to optimize the optical efficiency of the projector optics in order to scale down electrical power level to avoid overheating the small light emitting source without reducing the luminous flux of the projected image output. While high power solid state lasers that can efficiently produce highly collimated, coherent light might improve power efficiency, the use of coherent light may produce speckle, decreasing projected image quality. Also, the use of laser light raises concerns about eye safety, particularly under electrical or mechanical fault conditions.

As illustrated in the embodiments described below, optical components are assembled in improved combinations to reach desired high levels of luminous flux with low levels of electrical power in a miniature projection subsystem. The use of coherent light sources is avoided. The portability efficacy of the projection subsystem is enhanced. In particular, many optical losses that typically occur when light passes through air between conventional projector optics components are avoided.

Projection subsystems disclosed herein are capable of operation in a region 110 in graph 100 which has high portability efficacy. The region 110 is limited to a volume of no more than 14 cubic centimeters and an efficiency of no less than 3.8 lumens for 1 watt.

Another measure of portability efficacy comprises a thickness of an projection subsystem along its thinnest axis. An projection subsystem is best suited for use in a pocket portable device when the projection subsystem has a thickness of less than 14 millimeters along a thickness axis. Another aspect of portability efficacy is luminous flux. An projection subsystem is best suited for use in a pocket portable device when the luminous flux is at least 3 lumens.

FIG. 2 illustrates a projection subsystem 200. The projection subsystem 200 is useful for projecting still or video images from miniature electronic systems such as cell phones, personal digital assistants (PDA's), global positioning system (GPS) receivers. Projection subsystem 200 receives electrical power and image data from the miniature electronic system (not illustrated in FIG. 2) into which it is embedded. Projection subsystem 200 is useful as a component part of a miniature projector accessory for displaying computer video. Projection subsystem 200 is useful in systems that are small enough to be carried, when not in use, in a pocket of clothing, such as a shirt pocket. Images projected by the projection subsystem 200 can be projected onto a reflective projection screen, a light-colored painted wall, a whiteboard or sheet of paper or other known projection surfaces. Projection subsystem 200 can be embedded, for example, in a portable computer such as a laptop computer or a cell phone.

Projection subsystem 200 comprises a light engine 202. The light engine 202 provides a light beam 204. The light engine includes a collection lens 206, a collimator 208 and a solid state light emitter 210. According to one aspect, the collection lens 206 comprises a hyperhemispheric ball lens. According to one aspect, the hyperhemispheric ball lens is arranged as taught in US Patent Publication US 2007/0152231.

The solid state light emitter 210 receives electrical power 212 with an electrical power level. The solid state emitter 210 thermally couples to a heat sink 214. The solid state light emitter provides an emitter light beam with an emitter luminous flux level. According to one aspect, the light beam 204 comprises incoherent light. According to another aspect the light beam 204 comprises illumination that is a partially focussed image of the solid state light emitter 210. According to yet another aspect the solid state light

emitter 210 comprises one or more light emitting diodes (LED's). According to another aspect, the collection lens 206 comprises a hemispheric ball lens. According to another aspect, the collimator 208 comprises a focusing unit comprising a first fresnel lens having a first non-faceted side for receiving a first non-collimated beam and a first faceted side for emitting the collimated beam; and a second fresnel lens having a second non faceted side for substantially directly receiving the collimated beam and second faceted side for emitting an output beam. According to another aspect the solid state light emitter 210 can be arranged as shown in US Provisional Application 60/820,883. According to another aspect the light engine 202 can be arranged as shown in US Provisional Applications 60/820,887, 60/820,888, 60/821,032, 60/838,988.

The projection subsystem 200 comprises a refractive body 220. The refractive body 220 receives the light beam 204. The refractive body 220 provides a polarized beam 222. The refractive body 220 includes an internal polarizing filter 224. One polarized component of the light beam 204 is reflected by the internal polarizing filter 224 to form the polarized beam 222. According to one aspect, the refractive body is formed or utilized according to one or more aspects of US Patent Publication US 2007/0023941 A1 Duncan et al., US Patent Publication US 2007/0024981 A1 Duncan et al., US Patent Publication US 2007/0085973 A1 Duncan et al., and US Patent Publication US 2007/0030456 Duncan et al. The refractive body 220 comprises a first external lens surface 226 and a second external lens surface 228. According to one aspect, the external lens surfaces 226, 228 have curved lens surfaces and have non-zero lens power. According to another aspect, the external lens surface 226 comprises a convex lens surface that is useful in maintaining a small volume for the projection subsystem 200. According to another aspect, the external lens surfaces 226, 228 are flat. According to one aspect, the refractive body 220 comprises plastic resin material bodies 230, 232 on opposite sides of the internal polarizing filter 224. According to another aspect, the internal polarizing filter 224 comprises a multilayer optical film. According to another aspect, the refractive body 220 comprises a multifunction optical component that functions as a polarizing beam splitter as well as a lens. By combining the polarizing beam splitter and lens functions in a multifunction refractive body, losses that would otherwise occur at air interfaces between separate beam splitters and lenses are avoided.

The projection subsystem 200 comprises an image-forming device 236. The image-forming device 236 receives image data on electrical input bus 238. The image-forming device 236 receives the polarized beam 222. The image-forming device 236 selectively reflects the polarized beam 222 according to the image data. The image-forming device 236 provides an image 240 with a polarization that is rotated relative to the polarization of the polarized beam 222. The image-forming device 236 provides the image 240 to the refractive body 220. The image 240 passes through the internal polarizing filter 224. According to one aspect, the image-forming device 236 comprises a liquid crystal on silicon (LCOS) device.

The projection subsystem 200 comprises a projection lens assembly 250. The projection lens assembly 250 comprises multiple lenses indicated schematically at 252, 254, 256, 258, 260. The projection lens assembly 250 receives the image 240 from the refractive body 220. The projection lens assembly 250 provides an image projection beam 262 having a projected luminous flux that is suitable for viewing. According to one aspect the projected luminous flux is no less than 3 lumens. According to another aspect, a ratio of the projected luminous flux to the electrical power level is at least 3.8 lumens for 1 watt. According to another aspect, the ratio of the projected luminous flux to electrical power level is at least 7 lumens per watt. According to another aspect, the ratio of projected luminous flux to electrical power level is at least 10 lumens per watt. According to another aspect, the collection efficiency ratio is at least 38.5%. The collection efficiency ratio is defined as a ratio of the polarized luminous flux impinging on an active surface of the image forming device 236 to the luminous flux emitted from the unpolarized solid state light emitter 210.

According to another aspect, the projection subsystem 200 has an electrical power level of no more than 3.6 watts. According to another aspect, the projection subsystem 200 has a volume of less than 14 cubic centimeters. According to another aspect, the projection subsystem 200 has a thickness of less than 14 millimeters.

According to another aspect, the projection subsystem 200 has an F number that is less than 2.4. According to another aspect, the projection subsystem has an ANSI contrast ratio of at least 30:1. According to another aspect, the projection subsystem has an ANSI contrast ratio of at least 50:1. According to another aspect, the projection subsystem has an on/off contrast ratio of at least 100:1.

FIG. 3A illustrates a projection subsystem 300. Projection subsystem 300 is similar to projection subsystem 200 except that an anamorphic optical device 302 is included in the projection subsystem 300. Reference numbers used in FIG. 3A that are the same as reference number used in FIG. 2 represent the same or similar features. In other respects, the projection subsystem 300 is similar to projection subsystem 200. The anamorphic optical device 302 alters an aspect ratio of a light beam 304. The anamorphic optic device 302 changes light beam shape to adapt a first aspect ratio in the light engine 202 to a second different aspect ratio in the refractive body 220. According to one aspect, the first aspect ratio is 1:1 and the second aspect ratio is 16:9. According to another aspect the first aspect ratio is 1:1 and the second aspect ratio is 4:3. According to one aspect, the second aspect ratio matches an aspect ratio of the image forming device 236. According to one aspect the anamorphic optical device 302 comprises an anamorphic lens as illustrated in FIG. 3A. According to another aspect illustrated in FIG. 3B, an anamorphic surface 306 provided on a refractive body 320 serves as an anamorphic optical device. In other respects the refractive body 320 is similar to the refractive body 220 in FIG. 3A.

According to another aspect, a polarization filter can be positioned at locations 330 or 332 in FIG. 3A. The polarization filter at location 330 or 332 enhances optical contrast ratio of the optical subsystem 300. According to one aspect, the polarization filter positioned at locations 330, 332 comprises a multilayer optical film.

FIG. 4 illustrates an oblique view of the projection subsystem 300 of FIG. 3. The projection subsystem 300 has a thickness 402. The projection subsystem 300 has a cross-sectional area 400 which is indicated by a stippled planar surface that is perpendicular to the thickness 402. The cross-sectional area 400 includes the areas of components 206, 208, 236, 220, 250, 302 and intervening air spaces between the components which carry useful light. The projection subsystem 300 has a volume that is a mathematical product of the thickness 402 and the cross-sectional area 400.

FIGS. 5A, 5B illustrate portions of projection subsystem 500, 510 that are similar to projection subsystem 200 or 300. Projection subsystem 500 includes a filter 502. The filter 502 is adjacent the collimator 208. According to one aspect, the filter 502 comprises an optical component that is separate from the collimator 208. According to another aspect, the filter 502 comprises a filter layer on the collimator 208. According to one aspect, the collimator 208 is between the filter 502 and the lens 206 as illustrated in FIG.

5A. According to another aspect illustrated in FIG. 5B, a filter 504 is between the collimator 208 and the lens 206. The filters 502, 504 comprise a blue blocking filter that also blocks ultraviolet (UV) radiation. The blue blocking filter blocks blue and ultraviolet light at wavelengths which tend to deteriorate refractive optical devices, while passing the portion of the blue spectrum desired to be present in the projected image. The filter 502 or 504 blocks undesired light from reaching the refractive body 220.

FIGS. 5C, 5D illustrate portions of projection subsystem 520, 540 that are similar to projection subsystem 200 or 300. Projection subsystem 520 includes a filter 522. The filter 522 is positioned between the refractive body 220 and the projection lens assembly 250. Projection subsystem 540 includes a refractive body 220A that includes a filter 542 adjacent a polarizing filter 224. The filter 542 is positioned between the polarizing filter 224 and a plastic resin body 230. The filters 522, 542 comprise polarizing filters. The polarizing filters 522, 542 increase the contrast of the projected image. According to one aspect, a projection subsystem according to FIG. 5D is described in US Patent Application titled "Polarizing Beam Splitters Incorporating Reflective and Absorptive Polarizers and Image Display Systems Thereof," identified as Application Serial No. 11/457,599.

FIG. 6 illustrates a projection subsystem 600 that is similar to projection subsystem 300 in FIG. 4 except that projection subsystem 600 comprises a plate heat sink 602 whereas projection subsystem 300 in FIG. 4 comprises a heat sink 214 that has protrusions such as fins or pins. In other respects, projection subsystem 600 is similar to projection subsystem 300. According to one aspect, the plate heat sink 602 has a lower plate surface 604 that is exposed at an outer package surface of a pocket portable electronic package such as a cell phone, personal digital assistant (PDA), global positioning system (GPS) or similar pocket device. According to another aspect, the plate heat sink 602 makes thermal contact to other elements in the electronic device to dissipate the heat. According to another aspect, during use, the lower plate surface 604 can be place in contact with an accessory external heat sink for extended use.

FIG. 7 illustrates a projection subsystem 700 that is similar to the projection subsystem 300 in FIG. 3A, except that the projection subsystem 700 includes a polarization film 702 disposed along an optical path between the collection lens 206 and the refractive body 220. According to one aspect, the polarization film 702 is disposed between a collimator 208 and the refractive body 220 as illustrated in FIG. 7. The

polarization film 702 reflects polarized light back toward the reflective surface of a solid state light emitter 210 to provide light recycling. Inclusion of the polarization film 702 increases the luminous flux of the projection subsystem. According to one aspect, polarization recycling is as described in US Patent Application 11/772,609 filed July 2,
5 2007.

FIG. 8 illustrates a projection subsystem 800 that is similar to the projection subsystems of FIGS. 3A, 7. The projection subsystem 800 includes an enclosure 802 that encloses at least portions of the optical components 206, 208, 702, 302, 220 and protects optical component surfaces from contamination and moisture. According to one aspect,
10 the enclosure 802 may include an air filter 806. The air filter 806 restricts flow of air, filters out contamination and equalizes pressure between an interior of the enclosure 802 and the surrounding atmosphere. According to one aspect, the air filter 806 includes a dessicant 808 that reduces humidity inside the enclosure 802. According to another aspect, the enclosure 802 serves a mechanical mounting for optical components.

The enclosure 802 is coupled to a lens assembly guide tube 804. A projection lens assembly 250 is slidably mounted in the guide tube 804. The projection lens assembly 250 includes an actuation lever 810 that can be mechanically actuated to move the position of the projection lens assembly 250 relative to the image forming device 236. The movement of the projection lens assembly 250 comprises a focus adjustment. According to one
20 aspect, the projection lens assembly 250 fits closely in the guide tube 804 to provide a seal that prevents entry of contamination into the enclosure 802. According to another aspect, one or more O-rings (not illustrated) are provided between the projection lens assembly and the guide tube 804 to provide a seal. According to yet another aspect, a bellows (not illustrated) is provided between an end of the projection lens assembly 250 and the guide
25 tube 804 to provide a seal.

FIG. 9 illustrates an oblique view of a projection subsystem 900 that is similar to the projection subsystem shown in FIG. 2. The projection subsystem 900 comprises a solid state light emitter (not visible in FIG. 9) that is connected by electrical leads 902, 904 to a source of electrical power. The solid state light emitter is thermally coupled to a heat sink
30 906. The projection subsystem 900 includes a collection lens 908. The projection subsystem 900 includes an image forming device 912, a refractive body 914 and a projection lens 916.

FIG. 10A illustrates a light emitting diode 1000 that serves as an exemplary solid state light emitter, such as solid state light emitter 210 in FIG. 2. The light emitting diode 1000 is connected to electrical power by way of bond wires 1002, 1004. The light emitting diode 1000 includes light emitting regions 1008, 1010, 1012, 1014, 1016. Other regions of the light emitting diode 1000, such as regions 1018, 1020, 1022, 1024, 1026, 1028
5 comprise dark regions that include electrical conductor and that do not generate light. The image of the light emitting diode 1000 is thus a pattern of regions that generate light and regions that do not generate light. For use in projection, an image is desired that is relatively uniform in brightness such as illustrated in FIG. 10B. According to one aspect, providing the uniform brightness is as taught in US Patent Publication 2007/0153397 titled
10 "PROJECTION SYSTEM WITH BEAM HOMOGENIZER."

FIG. 11A illustrates an example of mounting an optical component in a projection subsystem. A molded component 1100 comprises an optical portion 1102 along an optical axis 1104 and a mounting flange portion 1106 that is molded in a unitary structure with the optical portion 1102. Optical portion 1102 comprises a lens, however, any of the
15 optical components of the projection subsystem can be used in place of the lens. The molded component is molded from refractive material such as transparent plastic resin. The mounting flange portion 1106 has rims 1108, 1110 that are shaped to mate with flanges of adjacent molded components. Rims can be attached to one another by friction
20 fit, snap fit, gluing, threads or other known attachment methods for plastic resin molded components.

FIG. 11B illustrates an example of mounting an optical component in a projection subsystem. An optical component 1120 is captured in grooves 1122, 1124 of mating halves of a mounting tube 1126. Multiple optical components mount in the mounting tube.
25 The mounting tube 1126 is assembled along a parting line 1128. Optical portion 1120 comprises a lens, however, any of the optical components of the projection subsystem can be similarly mounted in place of the lens.

FIG. 11C illustrates an example of mounting an optical component in a projection subsystem. An optical component 1130 is captured in a groove 1132 of a mounting channel 1134. A lid 1136 is secured to the mounting channel. Multiple optical components
30 mount in the mounting channel 1134. The mounting channel 1134 and the lid 1136 are assembled along a parting line 1138. Optical portion 1130 comprises a lens, however, any

of the optical components of the projection subsystem can be similarly mounted in place of the lens.

FIG. 11D illustrates an example of a combination of a refractive body 1150 (such as refractive body 220 of FIG. 2) molded together with mounting flange rims 1152, 1154, 1156 similar to those shown in FIG. 11A.

FIGS. 12A, 12B illustrate alternative embodiments of projection subsystems that have portability efficacy as described above. FIG. 12A illustrates a projection subsystem 1202 that includes a light engine 1204, an image-forming device 1206 and a projection lens assembly 1208. The image-forming device 1206 comprises a transmissive image forming device. FIG. 12B illustrates a projection subsystem 1222 that includes a light engine 124, an image-forming device 1226, an anamorphic lens 1228 and a projection lens assembly 1230. The image forming device 1226 is a reflective image forming device, such as an array of deflectable mirror pixels, and does not require polarized light for its operation.

EXAMPLE

A projection subsystem is constructed similar to FIGS. 7 and 9, with a refractive body similar to FIG. 3B. The solid state light emitter is a white LED made with a blue InGaN die, part number C450-EZ1000-S30000, plus a conformal yellow phosphor, produced by Cree, Inc. (4600 Silicon Drive, Durham, NC 27703). The collection lens, and its coupling to the LED, is described in US Patent Publication US 2007/0152231. The collimator is a Fresnel lens having a non-faceted side for receiving the non-collimated beam and a faceted side for emitting the collimated beam. The refractive body is a molded plastic polarizing beam splitter (PBS) as described in US Patent Publication US 2007/0024981. The reflective polarizing films, one within the PBS and one as shown as element 702 in FIG. 7, are manufactured by 3M Company (St. Paul, MN 55144) under the trade designation "VIKUITI" advanced polarizing films (APF). The image-forming device is an LCOS microdisplay with internal red, green and blue color filters, part number HX7007ATBFA, produced by Himax Display (2F, No.26, Zih Lian Road, Tree Valley Park, Sinshih, Tainan County 74445, Taiwan).

Measurements of dimensions and performance are summarized in the following table, in which IEC is an abbreviation for the International Electrotechnical Commission.

Parameter	Units	Minimum	Typical	Maximum	Measurement Standard	Comments
Resolution	pixels	640 x 480 (VGA)			IEC 61947-1	
Number of colors	number	16.8 million			IEC 61947-1	Three primaries with 8 bits per primary, $(2^8)^3 = 16777216$
Aspect Ratio	ratio	4:3			IEC 61947-1	
Projection distance range	meters	0.210		1.820	IEC 61947-1	
Projection distance for 10" image diagonal	meters		0.395			
Throw ratio range	ratio	0.600		0.700		
Throw ratio for 10" image diagonal	ratio		0.640			
Projection angle @ 10" screen	deg	28.5H x 21.6V				
Image size	inches	5.0	10.0	50.0	IEC 61947-1	
Luminous flux at 1 W, 80 C	lumens	3.7	4.2		IEC 61947-1	For 1 W of LED electrical power, 9 points average. Temperature measured at LED heatsink.
Light output uniformity	ratio	-70%		40%	IEC 61947-1	Brightest and dimmest of 13 points relative to 9 point average
Contrast Ratio	ratio	30:1	50:1		IEC 61947-1	Broad area (checkerboard) contrast (16 points)
On/Off Contrast	ratio	100:1	130:1			Full white, full dark contrast, 9 points
Color Gamut	ratio		40		% of NTSC @ CIE1931	
Correlated Color Temperature	K	5100		5800		

White Color Chromaticity	x		0.325		IEC 61947-1 CIE 1931	9 point average
	y		0.37			9 point average
Red Color Chromaticity	x		0.61		IEC 61947-1 CIE 1931	9 point average
	y		0.35			9 point average
Green Color Chromaticity	x		0.32		IEC 61947-1 CIE 1931	9 point average
	y		0.58			9 point average
Blue Color Chromaticity	x		0.175		IEC 61947-1 CIE 1931	9 point average
	y		0.225			9 point average
Length	mm	37.9	38.7	43.7	IEC 61947-1	Dimension in the direction of the optical axis of the projection lens, for 50", 20" and 5" image sizes on screen
Width	mm		31.1		IEC 61947-1	Maximum dimension in the direction of the long axis of the imager
Thickness	mm		12.6		IEC 61947-1	Maximum dimension in the direction of the short axis of the imager
Volume	cc	11.8	12.0	12.9		Volume, as defined in FIG. 4, for 50", 20" and 5" image sizes on screen

Although the present invention has been described with reference to preferred embodiments, workers skilled in the art will recognize that changes may be made in form and detail without departing from the spirit and scope of the invention.

5

WHAT IS CLAIMED IS:

1. A projection subsystem, comprising:

a light engine that provides a light beam, the light engine including a collection lens, a collimator and at least one solid state incoherent light emitter that receives an electrical power level and that is couplable to a heat sink and that provides a light beam with an emitter luminous flux level;

an image-forming device that receives image data and that receives at least a component of the light beam, the image-forming device providing an image;

a projection lens assembly that receives the image and that provides an image projection beam having a projected luminous flux level; and

the projection subsystem has a portability efficacy that comprises a ratio of luminous flux to electrical power level of at least 3.8 lumens for 1 watt, and a projection subsystem volume of less than 14 cubic centimeters.

2. The projection subsystem of Claim 1 and further comprising:

a refractive body that includes an internal polarizing filter, the refractive body receiving the light beam and providing a polarized component of the light beam to the image-forming device.

3. The projection subsystem of Claim 2 wherein the projection subsystem comprises a thickness of less than 14 millimeters.

4. The projection subsystem of Claim 2 and further comprising at least one lens surface that has a non-zero lens power adjacent the image-forming device.

5. The projection subsystem of Claim 4 when the lens surface comprises a curved surface of the refractive body.

6. The projection subsystem of Claim 2 wherein the portability efficacy comprises a portability efficacy limit selected from the group consisting of: an electrical power that is less than 3.6 watts, a ratio of projected luminous flux level to electrical power level is at

least 7 lumens per watt, and a ratio of projected luminous flux level to electrical power level is at least 10 lumens per watt.

7. The projection subsystem of Claim 2 and further comprising the heat sink.

5

8. The projection subsystem of Claim 2 wherein the refractive body comprises plastic resin material bodies on opposite sides of the internal polarizing filter.

10

9. The projection subsystem of Claim 2 wherein the internal polarizing filter comprises a multilayer optical film.

10. The projection subsystem of Claim 2 further comprising a reflective polarizer disposed adjacent the collimator.

15

11. The projection subsystem of Claim 2 comprising an anamorphic optic surface that adjusts an aspect ratio of the image projection beam.

12. A projection subsystem, comprising:

20

a light engine that provides a light beam, the light engine including a collection lens, a collimator and at least one solid state incoherent light emitter that receives an electrical power level and that is couplable to a heat sink and that provides a light beam with an emitter luminous flux level;

25

an image-forming device that receives image data and that receives at least a component of the light beam, the image-forming device providing an image;

a projection lens assembly that receives the image and that provides an image projection beam having a projected luminous flux level; and

30

the projection subsystem has a portability efficacy wherein the electrical power level is less than 3.6 watts, a projection subsystem volume is less than 14 cubic centimeters and a projection subsystem thickness is less than 14 millimeters.

13. The projection subsystem of Claim 12 wherein the portability efficacy comprises a ratio of the luminous flux level to the electrical power level of at least 3.8 lumens for 1 watt.

5 14. The projection subsystem of Claim 12 wherein the collection lens comprises a hemispheric ball lens.

10 15. The projection subsystem of Claim 12 wherein the light emitting diode source comprises at least one light emitting diode have non-uniform areas of higher and lower light emission, and the partial focusing fills regions of lower light emission to increase uniformity of illumination.

16. The projection subsystem of Claim 12 further comprising a reflective polarization light recycler disposed adjacent the collimator.

15

17. The projection subsystem of Claim 12 comprising an anamorphic optic surface that receives the light beam and shapes the light beam to change an aspect ratio of the light beam.

20 18. A method comprising, comprising:

providing a light beam from a light engine that includes a collection lens, a collimator and at least one solid state incoherent light emitter that receives an electrical power level and that is coupleable to a heat sink and that provides a light beam with an emitter luminous flux level;

25 receiving at least a component of the light beam at an image-forming device that receives image data, and providing an image from the image-forming device;

receiving the image at a projection lens assembly and providing an image projection beam having a projected luminous flux level; and

30 providing a portability efficacy that comprises a ratio of luminous flux to electrical power level of at least 3.8 lumens for 1 watt, and a projection subsystem volume of less than 14 cubic centimeters.

19. The method of Claim 18 and further comprising:

receiving the light beam at a refractive body that includes an internal polarizing filter, the refractive body providing a polarized component of the light beam to the image-forming device.

5

20. The method of Claim 18 and

arranging and selecting sizes of the optical components such that the projection subsystem has a volume that does not exceed 14 cubic centimeters.

10

21. The method of Claim 18 and

providing reflective polarization light recycling to provide a collection efficiency ratio of at least 38.5%.

15

22. The method of Claim 18 and

providing an anamorphic optic surface adjacent the refractive body, the anamorphic optic surface shaping an aspect ratio of the image beam.

23. The method of Claim 18 and

providing a focus adjustment that comprises an adjustment of a spacing between the projection lens assembly and the image forming device.

20

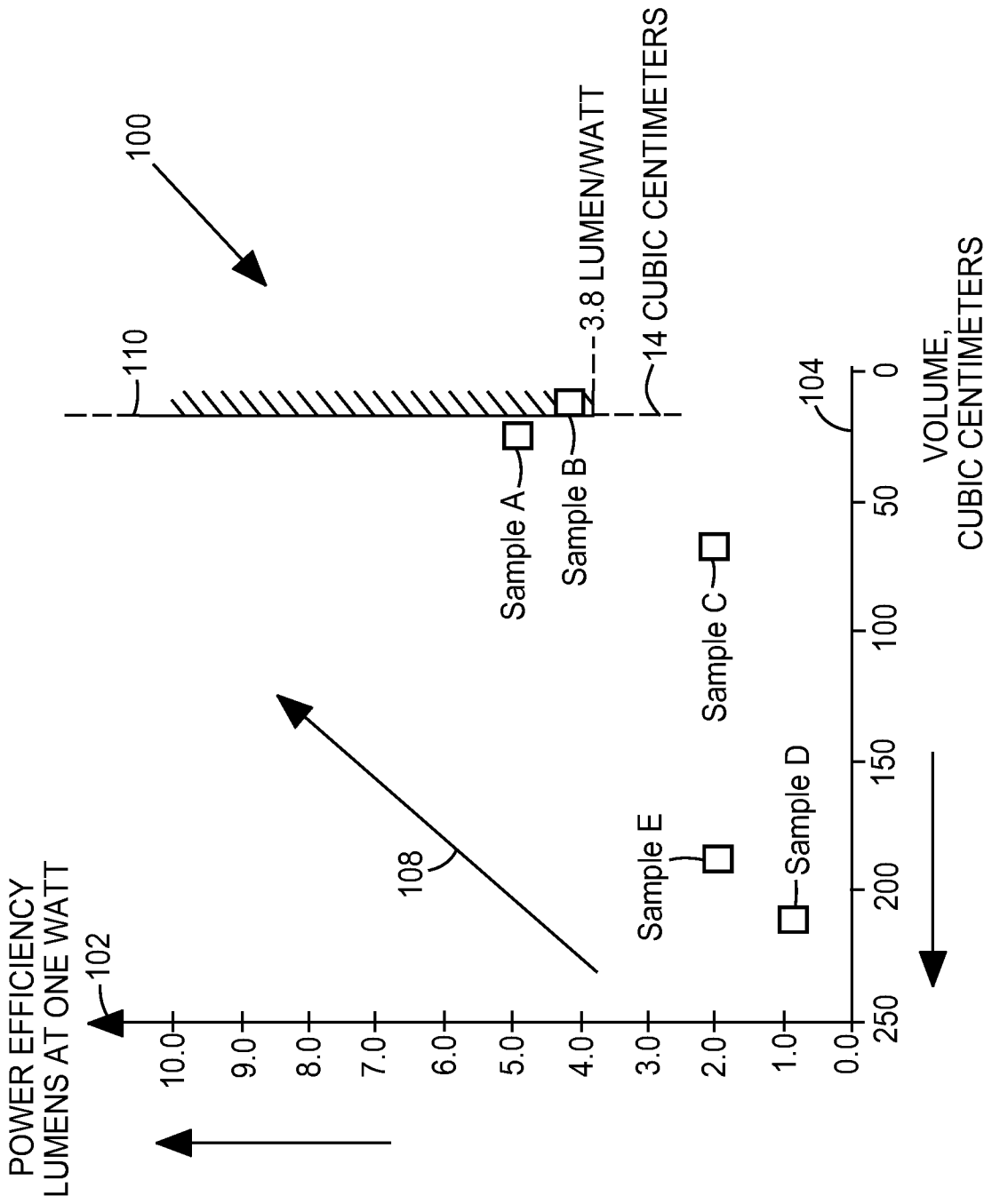
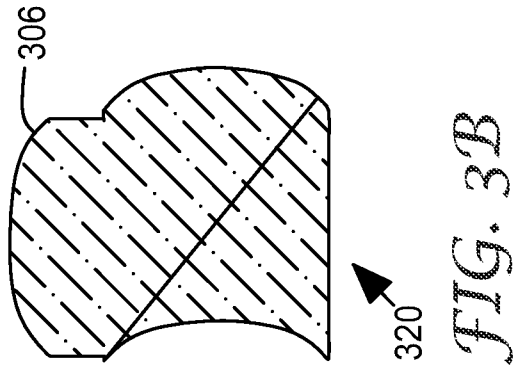
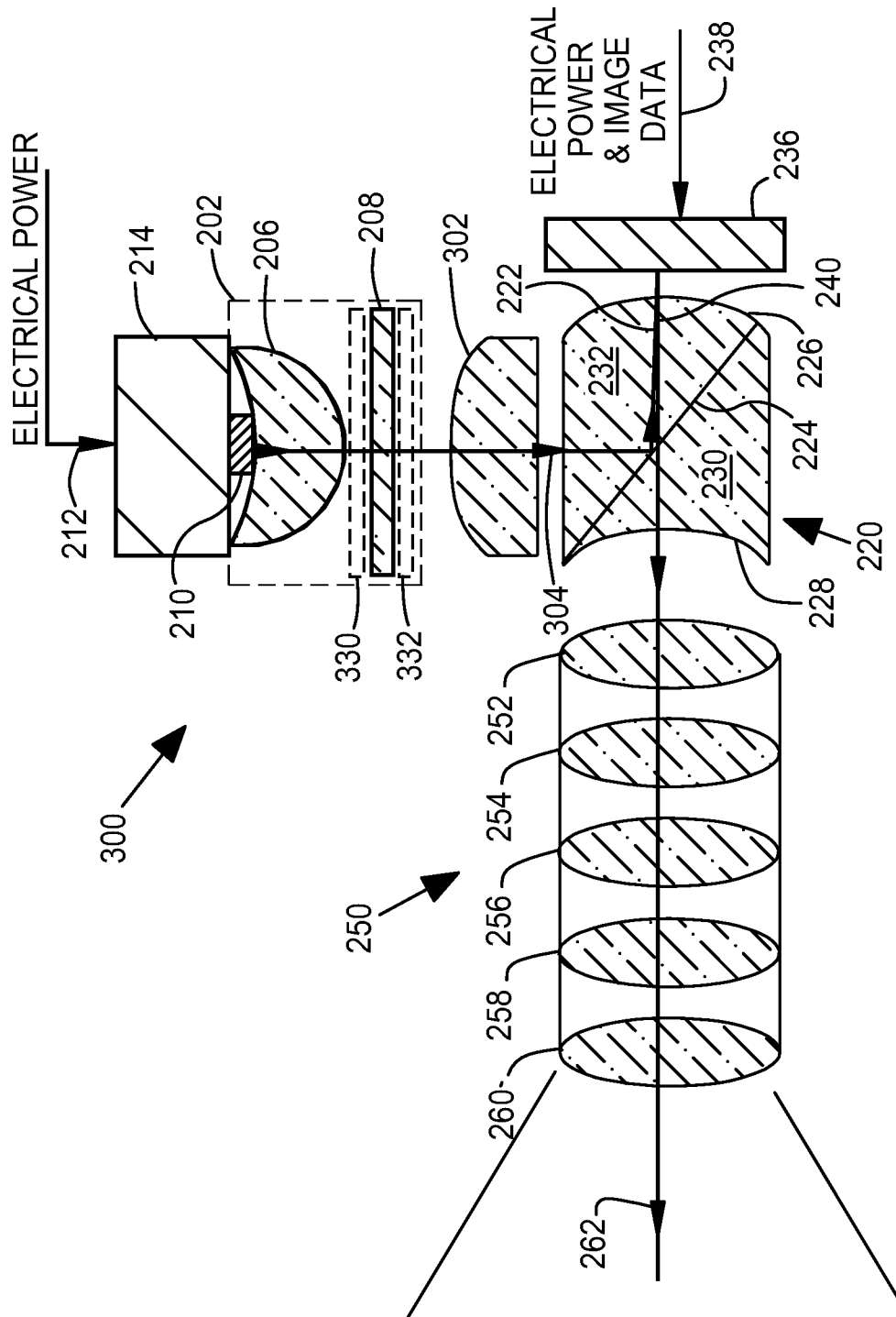

FIG. 1



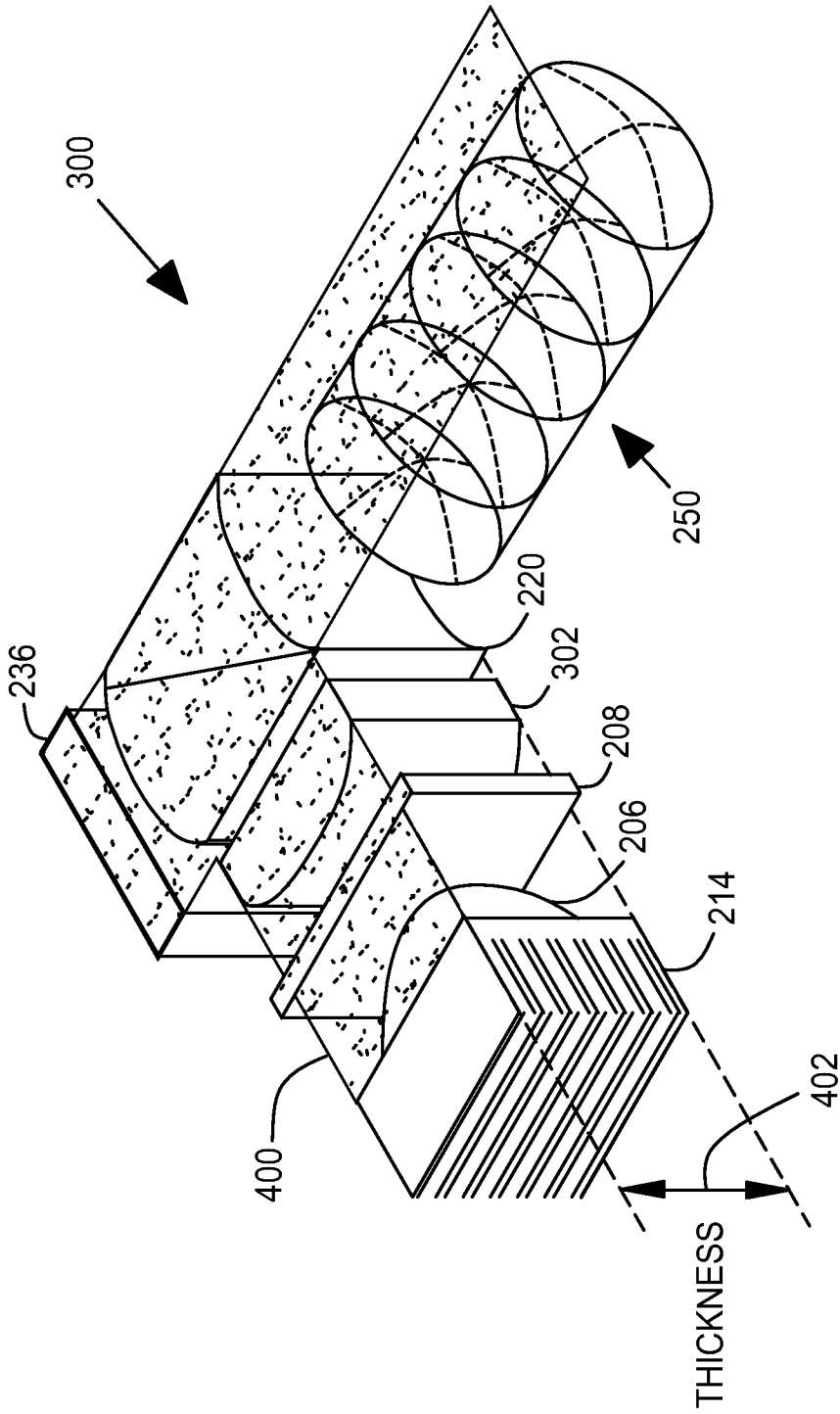

FIG. 4

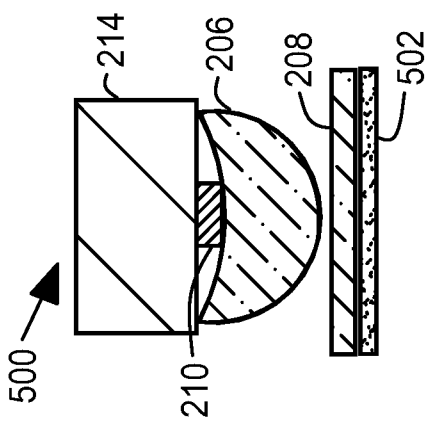

FIG. 5A

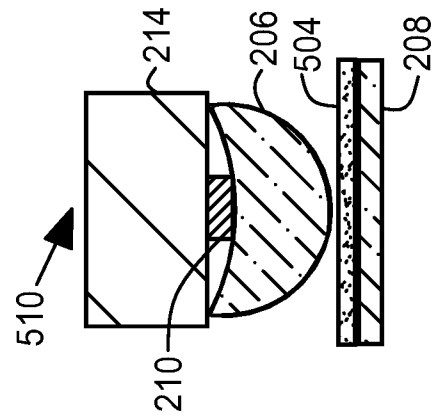

FIG. 5B

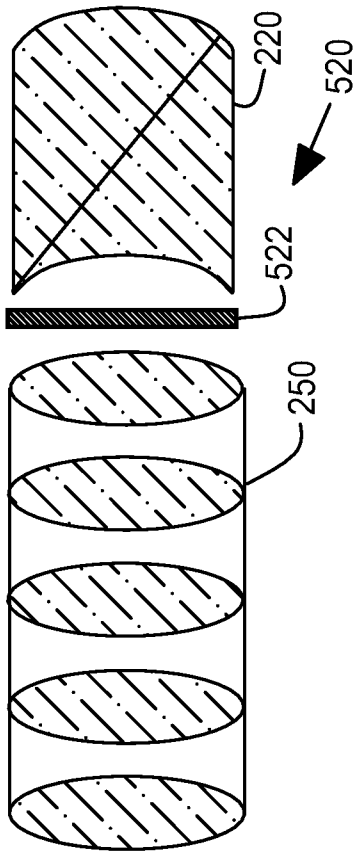

FIG. 5C

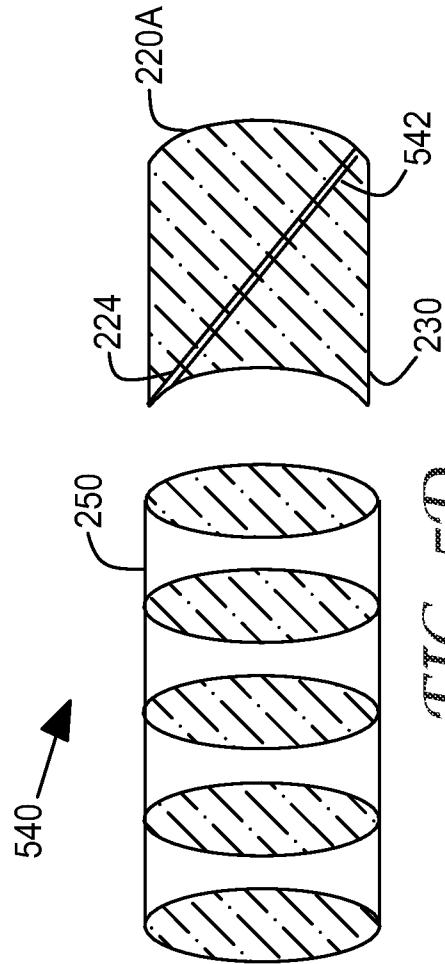

FIG. 5D

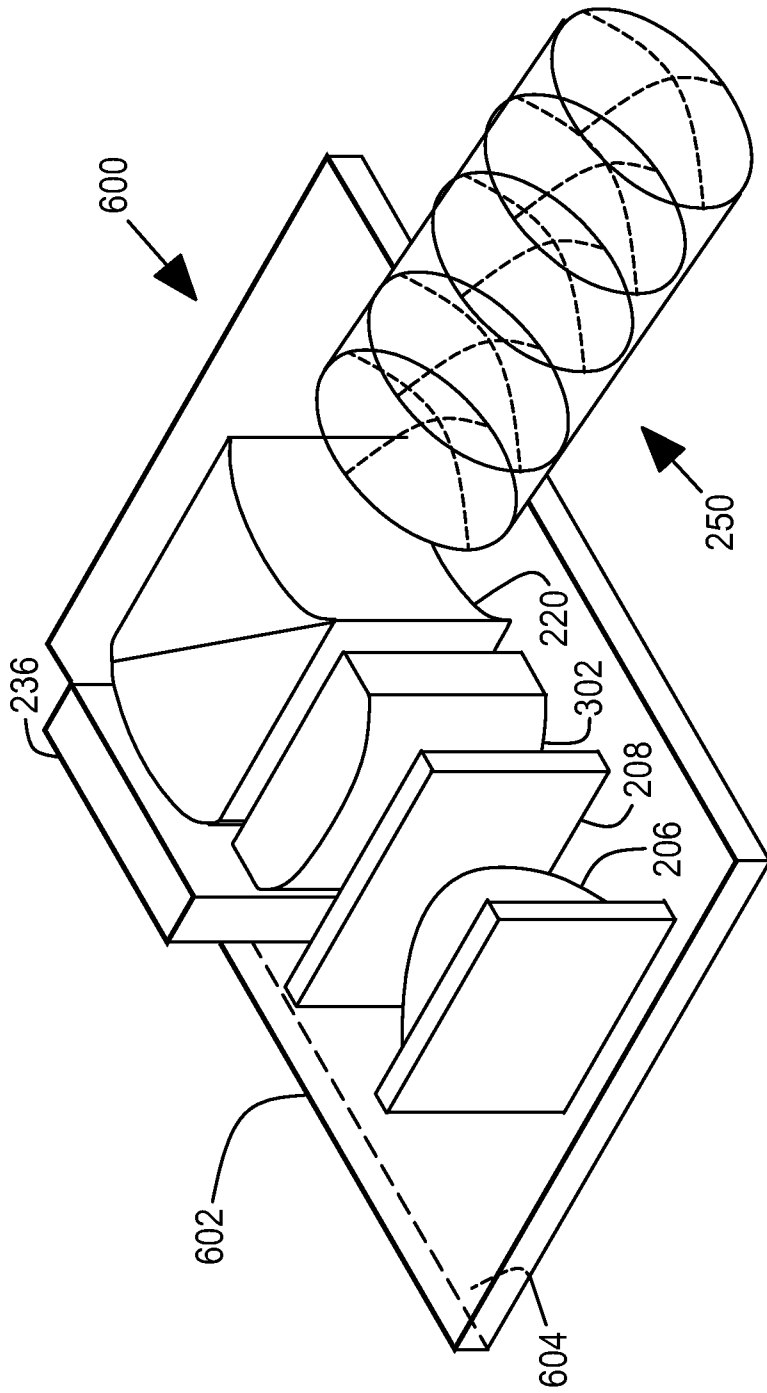

FIG. 6

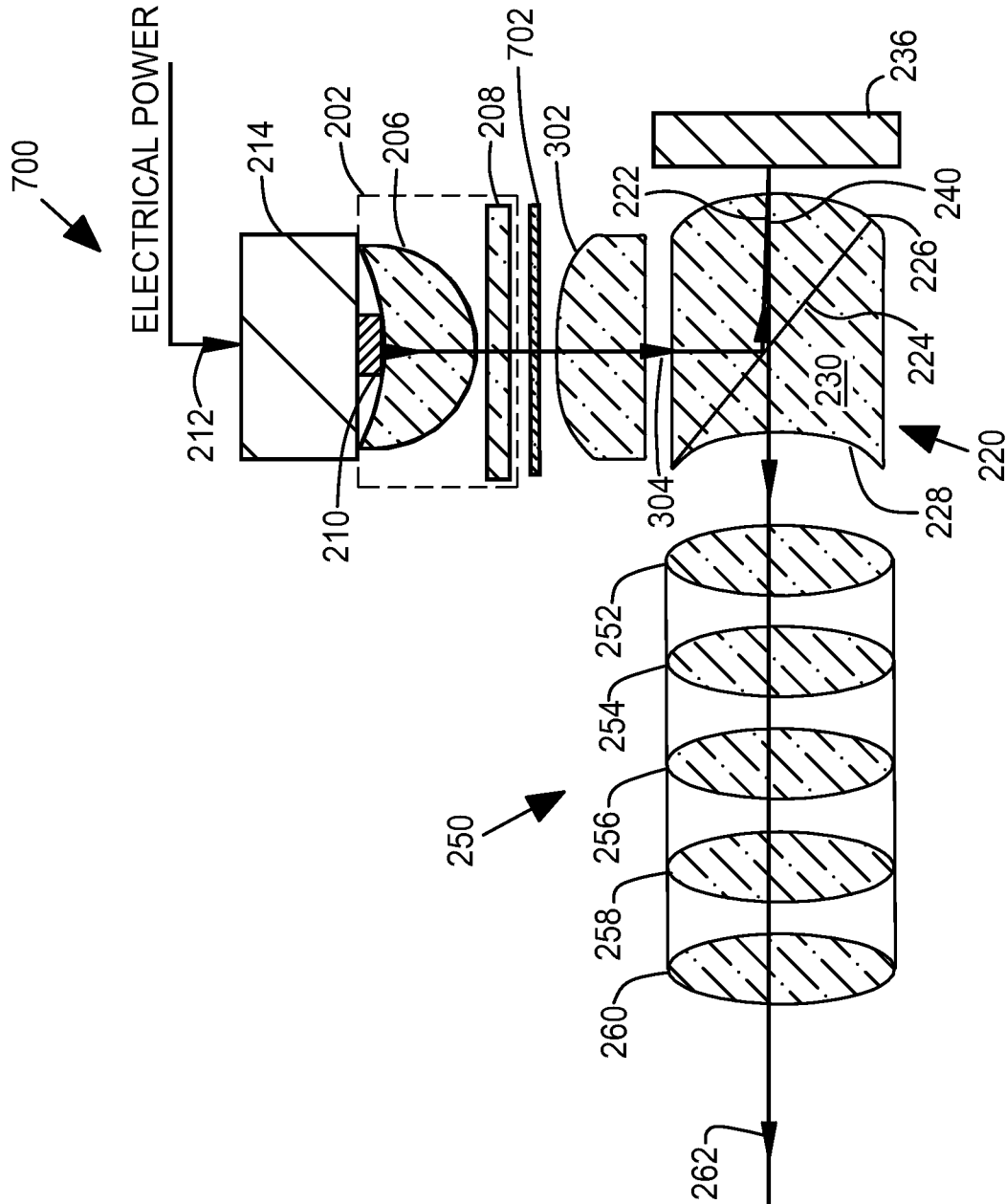

FIG. 7

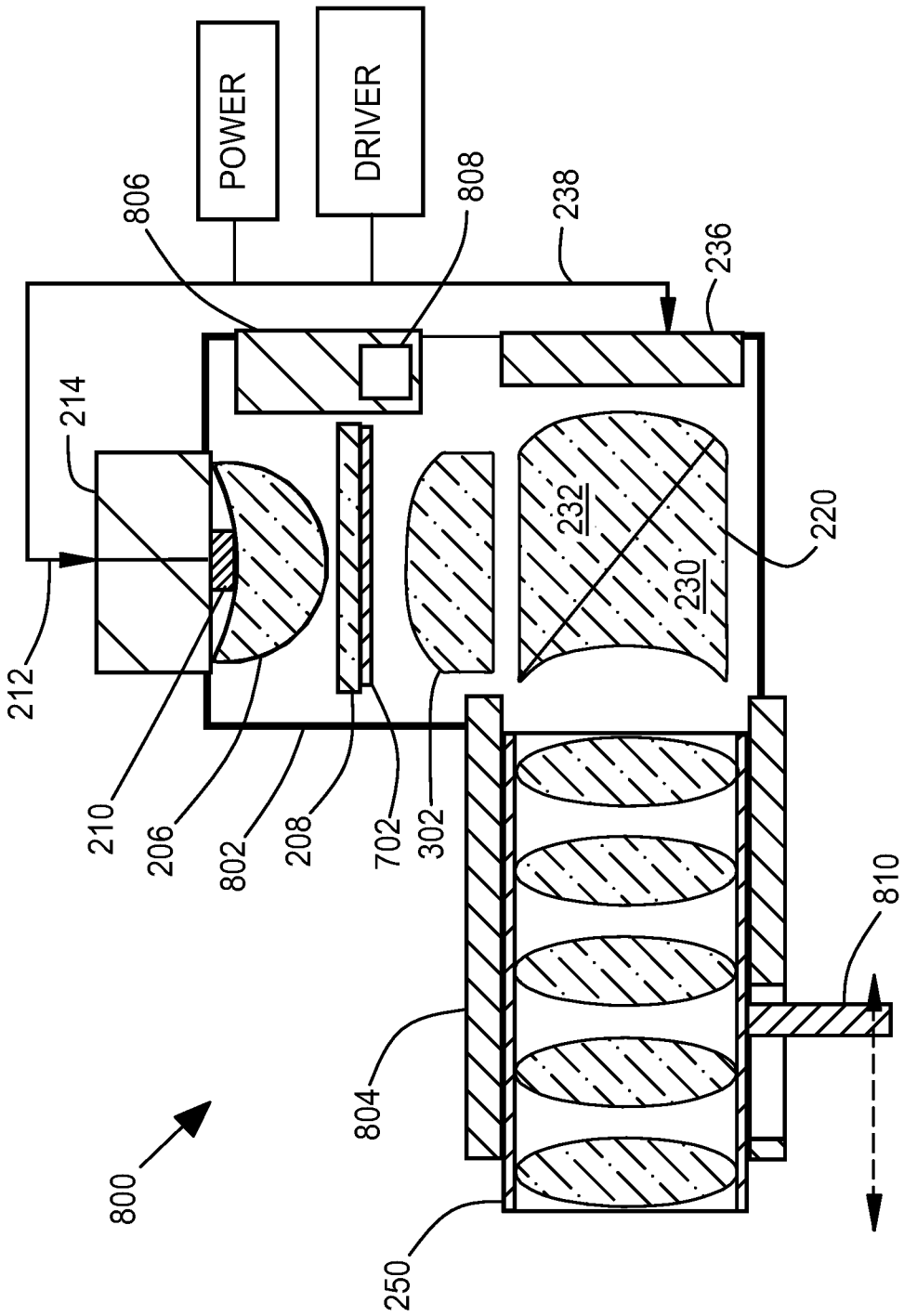

FIG. 8

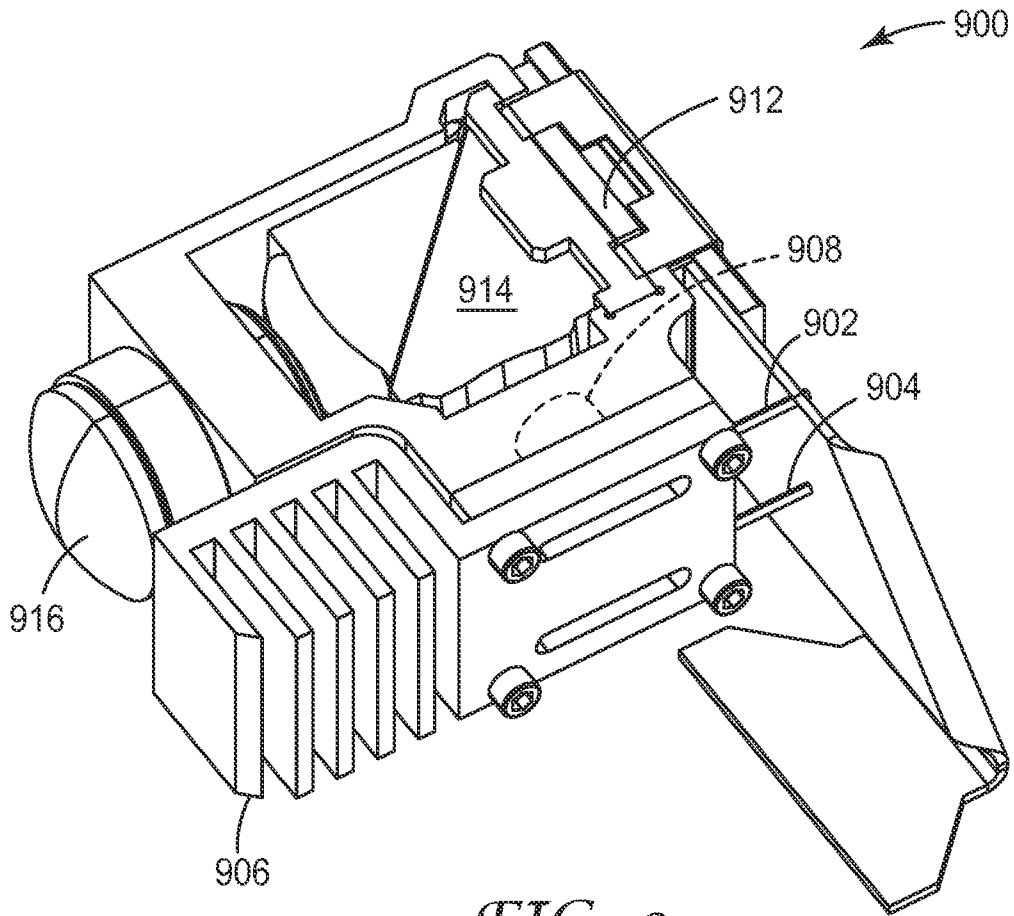
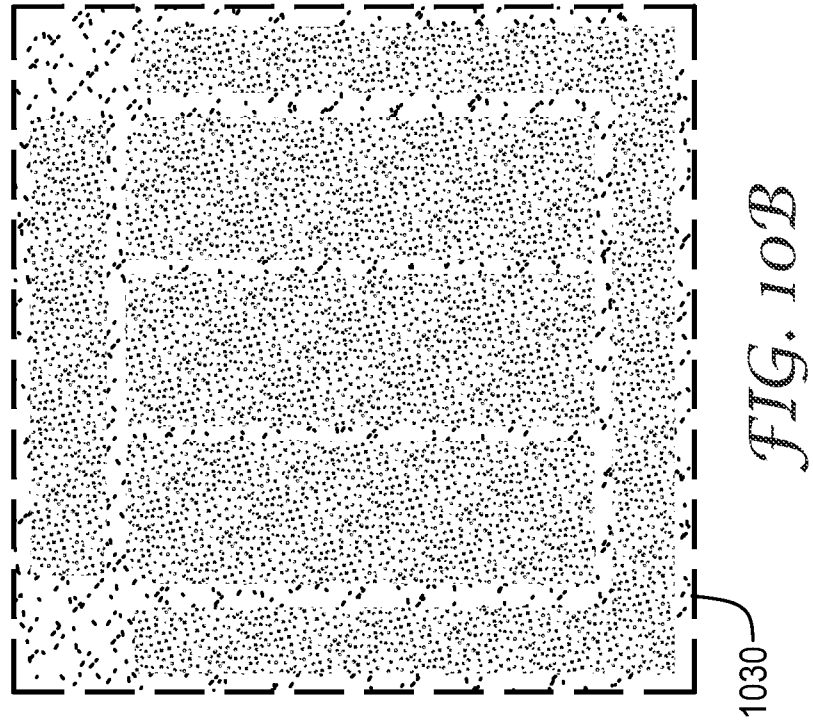
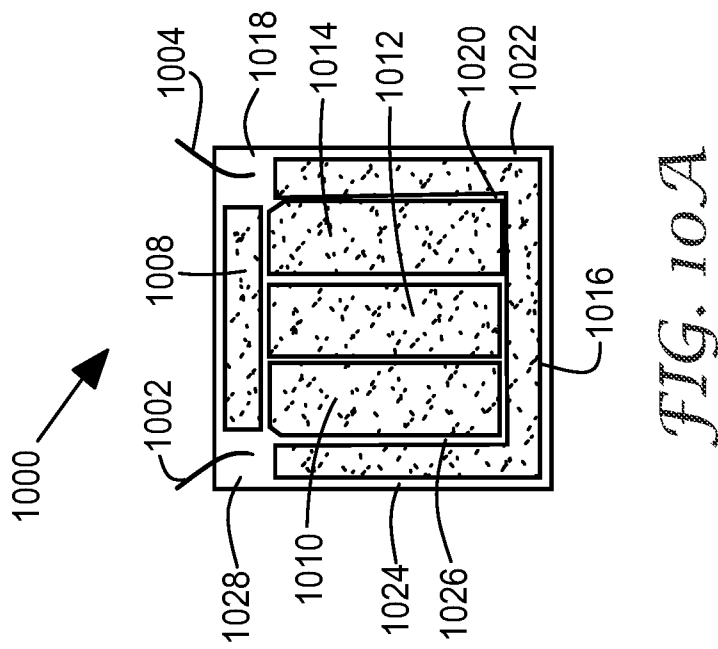

FIG. 9



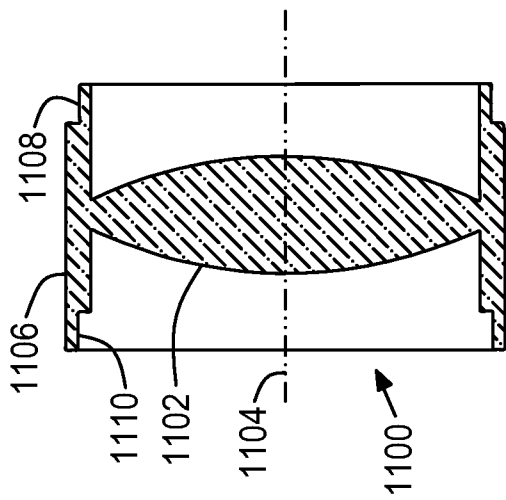

FIG. 11A

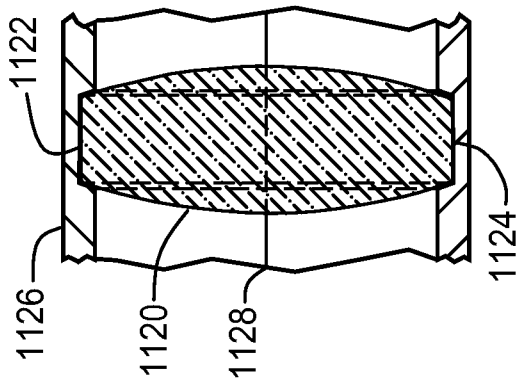

FIG. 11B

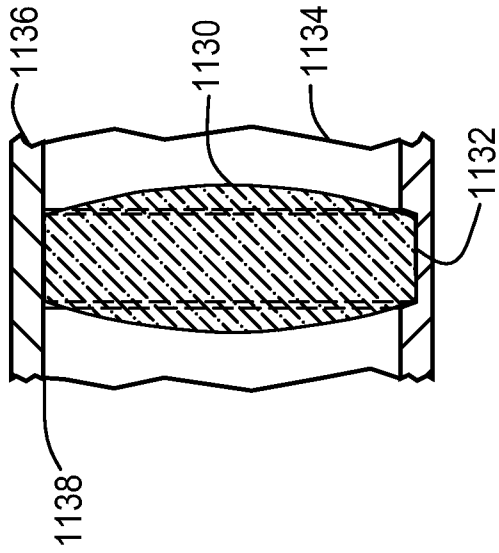

FIG. 11C

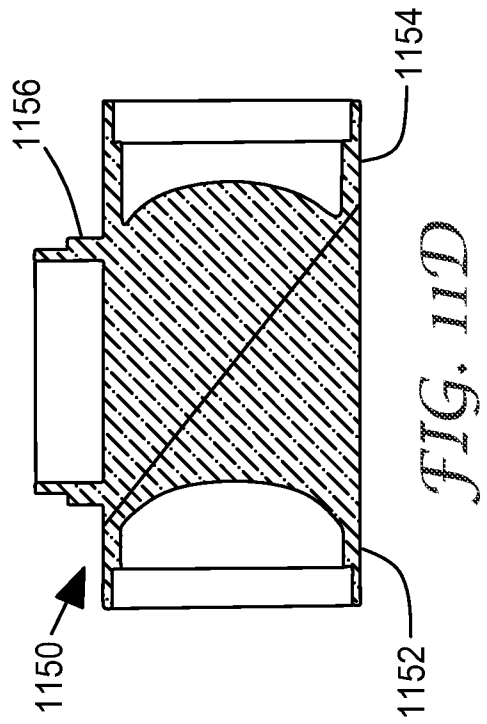

FIG. 11D

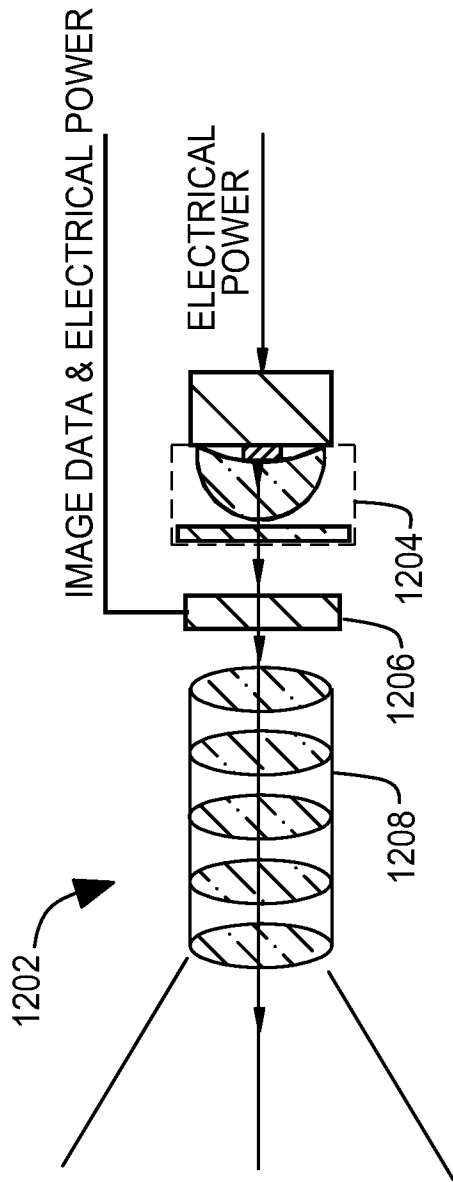

FIG. 12A

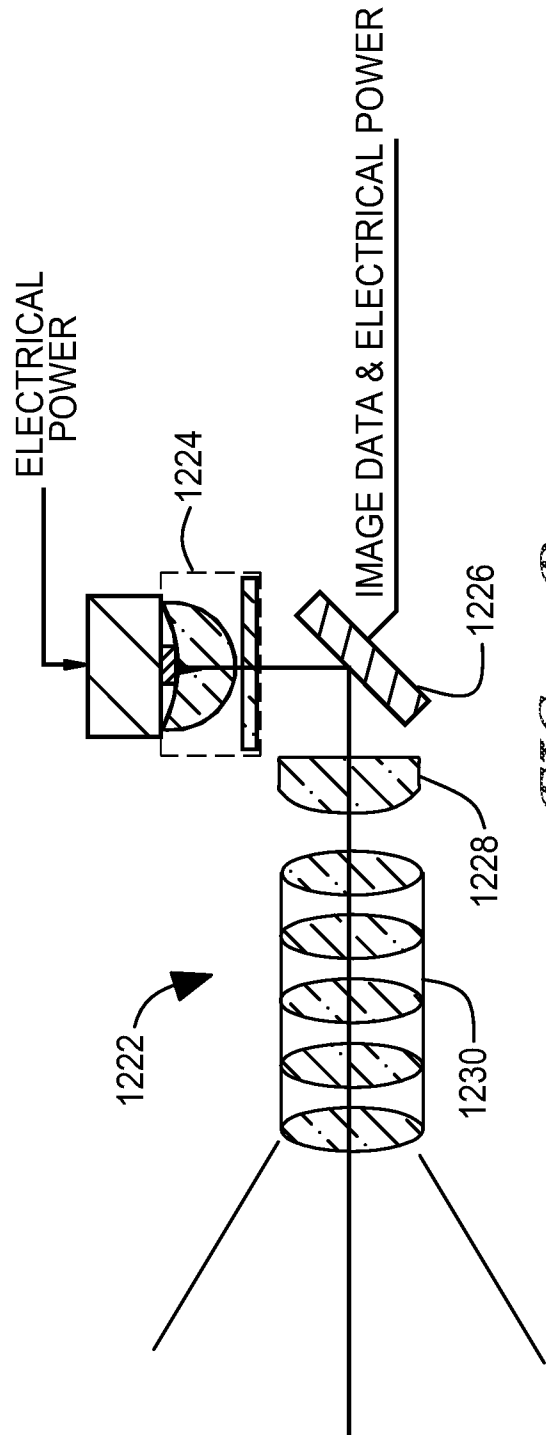

FIG. 12B

INTERNATIONAL SEARCH REPORT

International application No
PCT/US2007/074825A. CLASSIFICATION OF SUBJECT MATTER
INV. G03B21/00

According to International Patent Classification (IPC) or to both national classification and IPC

B. FIELDS SEARCHED

Minimum documentation searched (classification system followed by classification symbols)
G03B

Documentation searched other than minimum documentation to the extent that such documents are included in the fields searched

Electronic data base consulted during the international search (name of data base and, where practical, search terms used)

EPO-Internal, WPI Data, PAJ

C. DOCUMENTS CONSIDERED TO BE RELEVANT

Category*	Citation of document, with indication, where appropriate, of the relevant passages	Relevant to claim No.
X	HÜSEYIN, CUYPERS, DE SMETT: "Design of new collection systems for multi-LED light engines" PROCEEDINGS OF SPIE, vol. 6196, no. 619604, 21 April 2006 (2006-04-21), pages 1-11, XP002460367	1,3,6, 12,13, 15,18, 20,23
Y	page 3 - page 6 figure 1	2,4,5, 7-11,14, 16,17, 19,21,22
Y	WO 02/102087 A (3M INNOVATIVE PROPERTIES CO [US]) 19 December 2002 (2002-12-19) page 27, line 18 - line 29 figure 1	2,8-10, 19
	----- -/-- -----	

 Further documents are listed in the continuation of Box C. See patent family annex.

* Special categories of cited documents :

- *A* document defining the general state of the art which is not considered to be of particular relevance
- *E* earlier document but published on or after the international filing date
- *L* document which may throw doubts on priority claim(s) or which is cited to establish the publication date of another citation or other special reason (as specified)
- *O* document referring to an oral disclosure, use, exhibition or other means
- *P* document published prior to the international filing date but later than the priority date claimed

- *T* later document published after the international filing date or priority date and not in conflict with the application but cited to understand the principle or theory underlying the invention
- *X* document of particular relevance; the claimed invention cannot be considered novel or cannot be considered to involve an inventive step when the document is taken alone
- *Y* document of particular relevance; the claimed invention cannot be considered to involve an inventive step when the document is combined with one or more other such documents, such combination being obvious to a person skilled in the art.
- *&* document member of the same patent family

Date of the actual completion of the international search

28 November 2007

Date of mailing of the international search report

19/12/2007

Name and mailing address of the ISA/

European Patent Office, P.B. 5818 Patentlaan 2
NL - 2280 HV Rijswijk
Tel. (+31-70) 340-2040, Tx. 31 651 epo nl,
Fax: (+31-70) 340-3016

Authorized officer

Breccia, Luca

INTERNATIONAL SEARCH REPORT

International application No

PCT/US2007/074825

C(Continuation). DOCUMENTS CONSIDERED TO BE RELEVANT

Category*	Citation of document, with indication, where appropriate, of the relevant passages	Relevant to claim No.
Y	EP 0 763 763 A (MOTOROLA INC [US]) 19 March 1997 (1997-03-19) figure 6	4,5
Y	US 2006/139575 A1 (ALASAARELA MIKKO P [FI] ET AL) 29 June 2006 (2006-06-29) paragraph [0042]	7
Y	US 6 520 643 B1 (HOLMAN ROBERT L [US] ET AL) 18 February 2003 (2003-02-18) column 81, line 6 - line 13	11,17,22
Y	GB 2 413 858 A (AGILENT TECHNOLOGIES INC [US]; AGILENT TECHNOLOGIES INC [US]) 9 November 2005 (2005-11-09) figure 1	14
Y	EP 1 526 585 A (SEIKO EPSON CORP [JP]) 27 April 2005 (2005-04-27) paragraph [0119]	16,21
A	US 2005/206770 A1 (NATHANSON HARVEY C [US] ET AL) 22 September 2005 (2005-09-22) paragraph [0023] - paragraph [0033] figure 1	1,12,18
A	EP 1 389 018 A (INFOCUS CORP [US]) 11 February 2004 (2004-02-11) paragraph [0031]	1,12,18
A	US 2002/125324 A1 (YAVID DMITRIY [US] ET AL) 12 September 2002 (2002-09-12) paragraphs [0166], [0201], [0260]	1,12,18
A	RIEHMANN, KÜHMSTEDT, LIPPMANN, PALME, NOTNI: "Ultrakompakte Projektionsköpfe für die optische Messtechnik auf der Basis von OLED-Displays" PROCEEDINGS 105. DGAO JAHRESTAGUNG, 5 June 2004 (2004-06-05), XP002460368	1,12,18
A	WO 2004/084534 A (EXPLAY LTD [IL]; KAPELLNER YUVAL [IL]; MANOR GOLAN [IL]; ZALEVSKY ZEEV) 30 September 2004 (2004-09-30) page 28, line 29 - page 29, line 2 page 23, line 13 - page 24, line 2	1,12,18

INTERNATIONAL SEARCH REPORT

Information on patent family members

International application No

PCT/US2007/074825

Patent document cited in search report	Publication date	Patent family member(s)	Publication date
WO 02102087	A	19-12-2002	CN 1515120 A 21-07-2004 EP 1405528 A1 07-04-2004 JP 2004533019 T 28-10-2004 TW 577235 B 21-02-2004
EP 0763763	A	19-03-1997	JP 9127604 A 16-05-1997
US 2006139575	A1	29-06-2006	WO 2006067212 A1 29-06-2006
US 6520643	B1	18-02-2003	NONE
GB 2413858	A	09-11-2005	NONE
EP 1526585	A	27-04-2005	CN 1609701 A 27-04-2005 KR 20050039610 A 29-04-2005 US 2005110395 A1 26-05-2005
US 2005206770	A1	22-09-2005	EP 1714235 A2 25-10-2006 JP 2007527159 T 20-09-2007 WO 2005077002 A2 25-08-2005
EP 1389018	A	11-02-2004	NONE
US 2002125324	A1	12-09-2002	NONE
WO 2004084534	A	30-09-2004	JP 2006520932 T 14-09-2006 KR 20060015476 A 17-02-2006