



US00D976337S

(12) **United States Design Patent**  
**Ma**

(10) **Patent No.:** **US D976,337 S**

(45) **Date of Patent:** **\*\* Jan. 24, 2023**

(54) **TOY VEHICLE**

(74) *Attorney, Agent, or Firm* — Greenberg Traurig, LLP

(71) Applicant: **SLIS, Inc.**, Darien, IL (US)

(57) **CLAIM**

(72) Inventor: **Jiadong Ma**, Darien, IL (US)

The ornamental design for a toy vehicle, as shown and described.

(73) Assignee: **SLIS, Inc.**, Darien, IL (US)

(\*\*) Term: **15 Years**

(21) Appl. No.: **29/778,921**

(22) Filed: **Apr. 15, 2021**

(51) **LOC (14) Cl.** ..... **21-01**

(52) **U.S. Cl.**

USPC ..... **D21/561; D21/533**

(58) **Field of Classification Search**

USPC ..... D21/537, 533, 552, 548, 424, 434, 419,  
D21/427, 433, 530, 539, 550, 551, 561,  
(Continued)

(56) **References Cited**

**U.S. PATENT DOCUMENTS**

830,087 A 9/1906 Loomis  
885,517 A 4/1908 Prescott  
(Continued)

**FOREIGN PATENT DOCUMENTS**

CA 172579 3/2018  
CN 3517170 \* 4/2006  
(Continued)

**OTHER PUBLICATIONS**

“Mattel’s Hot Wheels Mars Rover Curiosity,” 2012, collectspace.com, site visited Dec. 9, 2021, URL: <http://www.collectspace.com/news/news-080112b.html> (Year: 2012).\*

(Continued)

*Primary Examiner* — Eric L Goodman

*Assistant Examiner* — Sarah L Smith

**DESCRIPTION**

FIG. 1 is a perspective view of a toy vehicle having a straight tire and having my design;

FIG. 2 is a front view of the toy vehicle of FIG. 1;

FIG. 3 is a rear view of the toy vehicle of FIG. 1;

FIG. 4 is a left side view of the toy vehicle of FIG. 1;

FIG. 5 is a right side view of the toy vehicle of FIG. 1;

FIG. 6 is a top view of the toy vehicle of FIG. 1;

FIG. 7 is a bottom view of the toy vehicle of FIG. 1;

FIG. 8 is a perspective view of a toy vehicle having a convex tire and having my design;

FIG. 9 is a front view of the toy vehicle of FIG. 8;

FIG. 10 is a rear view of the toy vehicle of FIG. 8;

FIG. 11 is a left side view of the toy vehicle of FIG. 8;

FIG. 12 is a right side view of the toy vehicle of FIG. 8;

FIG. 13 is a top view of the toy vehicle of FIG. 8;

FIG. 14 is a bottom view of the toy vehicle of FIG. 8;

FIG. 15 is a rear view of a third embodiment of a toy vehicle illustrating an environmental tread applied to a straight tire as shown in FIGS. 1-7;

FIG. 16 is a rear view of a fourth embodiment of a toy vehicle illustrating an environmental tread applied to a straight tire as shown in FIGS. 1-7;

FIG. 17 is a rear view of a fifth embodiment of toy vehicle illustrating an environmental tread applied to a straight tire as shown in FIGS. 1-7;

FIG. 18 is a rear view of a sixth embodiment of a toy vehicle illustrating an environmental tread applied to a straight tire as shown in FIGS. 1-7;

FIG. 19 is a rear view of a seventh embodiment of a toy vehicle illustrating an environmental tread applied to a straight tire as shown in FIGS. 1-7;

FIG. 20 is a rear view of an eighth embodiment of a toy vehicle illustrating an environmental tread applied to a straight tire as shown in FIGS. 1-7;

(Continued)

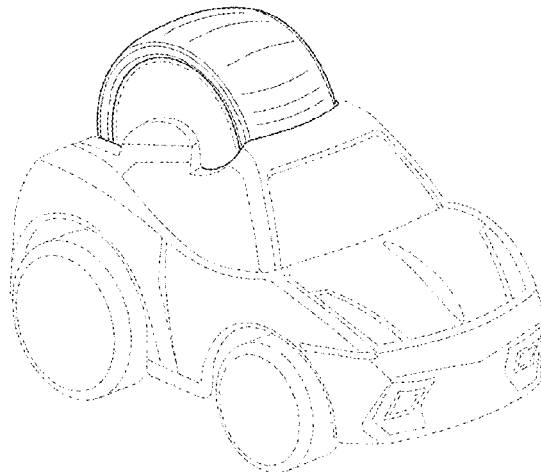
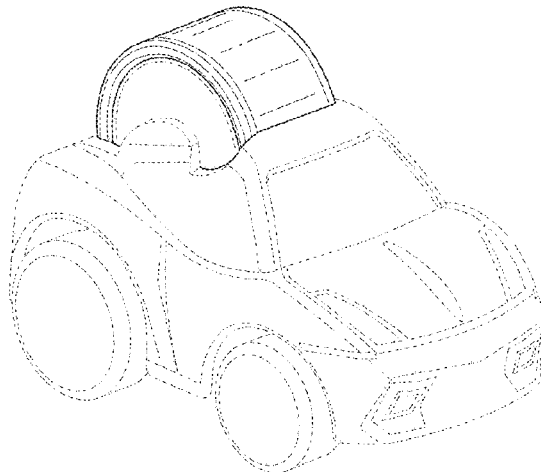

FIG. 21 is a left side view of a toy vehicle illustrating, but not claiming, an environmental wheel applied to a convex tire as shown in FIGS. 8-14; and,

FIG. 22 is a right side view of a toy vehicle illustrating, but not claiming, an environmental wheel applied to a convex tire as shown in FIGS. 8-14.

Features shown in dashed lines are features of the toy vehicle that form no part of the design claimed.

1 Claim, 22 Drawing Sheets

(58) Field of Classification Search

USPC ..... D21/562, 549; D12/12, 82, 83, 84, 86, D12/87, 88, 91

CPC .. B60L 8/00; A63H 7/04; A63H 11/12; A63H 17/00; A63H 17/25; B62M 1/00; B60G 21/00; B60G 7/00; B60G 11/00; B60G 2800/00; B62K 3/005; B62K 3/002; B62K 3/16

See application file for complete search history.

(56) References Cited

U.S. PATENT DOCUMENTS

1,136,854 A 4/1915 Wechsler  
 1,350,881 A 8/1920 Pfunder  
 1,359,081 A 11/1920 Lipps  
 D92,193 S 5/1934 Nelson  
 2,568,557 A \* 9/1951 Newbery ..... A63H 33/108  
 446/94  
 D217,874 S \* 6/1970 French ..... D21/763  
 3,698,125 A 10/1972 Hartling et al.  
 D241,262 S 8/1976 Kuna  
 D282,476 S \* 2/1986 Arigaya ..... D21/548  
 D282,677 S \* 2/1986 Arigaya ..... D21/562  
 D283,235 S \* 4/1986 Arigaya ..... D21/562  
 D318,698 S 7/1991 Roann  
 D336,936 S 6/1993 Shiraiishi  
 5,413,518 A 5/1995 Lin  
 D364,657 S 11/1995 Schmidt et al.  
 D381,710 S 7/1997 Kato  
 5,667,420 A \* 9/1997 Menow ..... A63H 17/004  
 180/22  
 D390,890 S \* 2/1998 Lun ..... D21/550  
 D412,542 S 8/1999 Lun  
 6,129,607 A \* 10/2000 Hoeting ..... A63H 17/004  
 446/396  
 6,171,171 B1 \* 1/2001 Barthold ..... A63H 17/28  
 446/219  
 6,394,878 B1 \* 5/2002 Wang ..... A63H 17/262  
 446/454  
 D458,314 S 6/2002 Allemeier  
 6,902,464 B1 6/2005 Lee  
 D574,296 S \* 8/2008 Keski-Luopa ..... D12/85  
 D597,151 S \* 7/2009 Ishikawa ..... D21/562  
 D677,345 S \* 3/2013 Isted ..... D21/551  
 D771,201 S \* 11/2016 Tompkin ..... A63H 17/28  
 D21/550  
 D803,329 S \* 11/2017 Tompkin ..... A63H 17/004  
 D21/550  
 D825,685 S \* 8/2018 Tompkin ..... A63H 17/262  
 D21/550  
 D834,110 S \* 11/2018 Tompkin ..... D21/550  
 D868,172 S \* 11/2019 Jin ..... A63H 33/108  
 446/94

D868,905 S \* 12/2019 Tompkin ..... D21/763  
 D870,206 S 12/2019 Reuckheim  
 D870,211 S \* 12/2019 Wozniak ..... A63H 17/28  
 D880,391 S 4/2020 Liu  
 D915,469 S 4/2021 Ninomiya et al.  
 D923,110 S \* 6/2021 Gamble ..... D21/548  
 2001/0044255 A1 \* 11/2001 Lee ..... A63H 17/004  
 446/469  
 2002/0137428 A1 \* 9/2002 Tilbor ..... A63H 17/262  
 446/465  
 2012/0241239 A1 \* 9/2012 Holroyd ..... B60K 5/02  
 180/210  
 2015/0130160 A1 5/2015 Li  
 2017/0036127 A1 \* 2/2017 Wang ..... A63H 17/28  
 2020/0368629 A1 \* 11/2020 Moss ..... A63H 17/21  
 D21/562

FOREIGN PATENT DOCUMENTS

CN 303529072 12/2015  
 CN 303889324 \* 10/2016 ..... A63H 17/262  
 CN 304920164 11/2018  
 CN 304981539 \* 1/2019 ..... A63H 17/26  
 EP 1074286 A2 \* 2/2001 ..... A63H 17/262  
 EP 1074286 A2 2/2001  
 WO WO-2015088082 A1 \* 6/2015 ..... A63H 17/26

OTHER PUBLICATIONS

“Stator Ride,” Mar. 25, 2017, youtube.com, site visited Dec. 9, 2021, URL: <https://www.youtube.com/watch?v=d5Nf9TMrLJw> (Year: 2017).\*

Wahid Ooi Abdullah, “Skinny vs. Fat: Does Tyre Width Matter?” Jun. 6, 2018, bikesrepublic.com, site visited, Dec. 9, 2021, URL: <https://www.bikesrepublic.com/featured/skinny-vs-fat-tyre-width-matter/> (Year: 2018).\*

Devin Connors, “Rocket League’s First Hot Wheels Car Has Arrived.” Dec. 18, 2018, rocketleague.com, site visited Dec. 9, 2021, URL: <https://www.rocketleague.com/news/rocket-league-hot-wheels-toy/> (Year: 2018).\*

Missy Sullivan, “These Vintage Hot Wheels Toys Are Worth Thousands of Dollars,” article updated Jul. 1, 2019, 1970 Maverick Hot Wheels/TopperToys, history.com, site visited Dec. 9, 2021, URL: <https://www.history.com/news/hot-wheels-most-collectible-valuable> (Year: 2019).\*

“Alomejor RC Tires RC Wheel Hub Drift Tires,” Mar. 19, 2021, amazon.com, site visited Dec. 9, 2021, URL: <https://www.amazon.com/dp/B08ZJG45N9/> (Year: 2021).\*

United States Patent and Trademark Office, Non-Final Office Action issued in U.S. Appl. No. 29/732,594, dated Nov. 23, 2021, 6 pgs. Morgan A. McDougald et al., “Experimental Studies on Traction Concepts: Endurance and Obstacle Testing,” Aug. 2013, researchgate.net, site visited Nov. 10, 2021, URL: <https://www.researchgate.net/figure/Concave-wheel-profile-The-main-objectives-of-the-three-prototypes-created-were-to-improve-fi> (Year: 2013).

“Kikkerland Zecar Windup,” Jul. 18, 2015 (Q&A), amazon.com, site visited Nov. 9, 2021, URL: <https://www.amazon.com/Kikkerland-1589-Zecar-Windup/dp/B000L2JVKW/> (Year: 2015).

“Green Rubber Kennedy AG,” Sep. 11, 2018, facebook.com, site visited Nov. 10, 2021, URL: <https://www.facebook.com/grka2003/photos/1818018698234729> (Year: 2018).

“Sgile Stunt Car Racing RC Rechargeable 5 Rounds 360 Spin Review,” Nov. 14, 2016, youtube.com, site visited Nov. 10, 2021, URL: <https://www.youtube.com/watch?v=t76BDi701xk> (Year: 2016).

United States Patent and Trademark Office, Final Office Action issued in U.S. Appl. No. 29/732,594, dated Jun. 10, 2022, 8 pgs.

\* cited by examiner

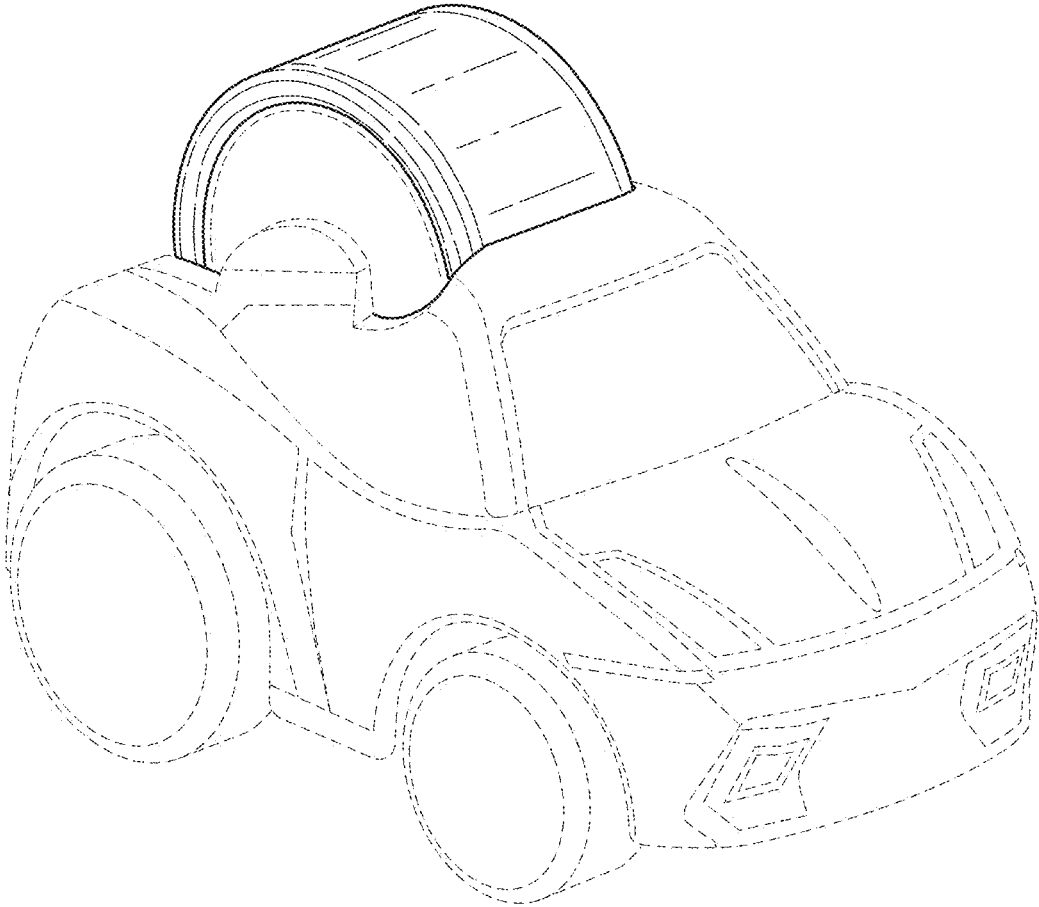

FIG. 1

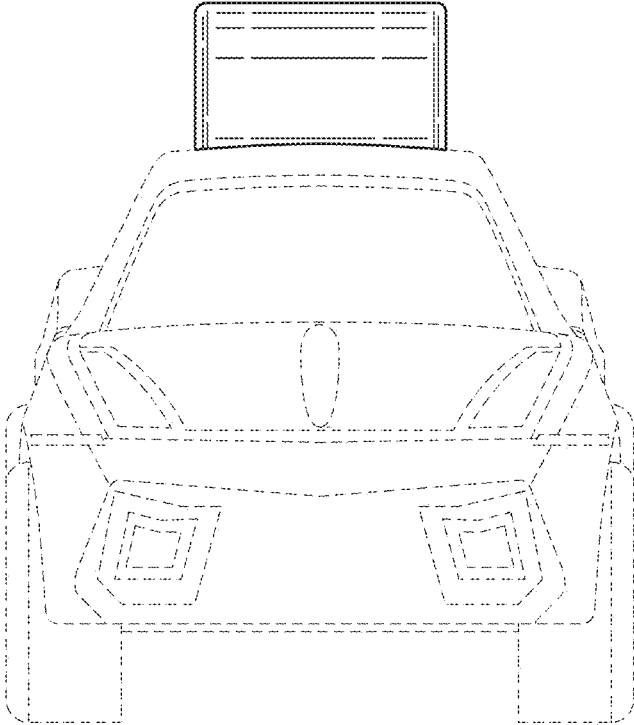

FIG. 2

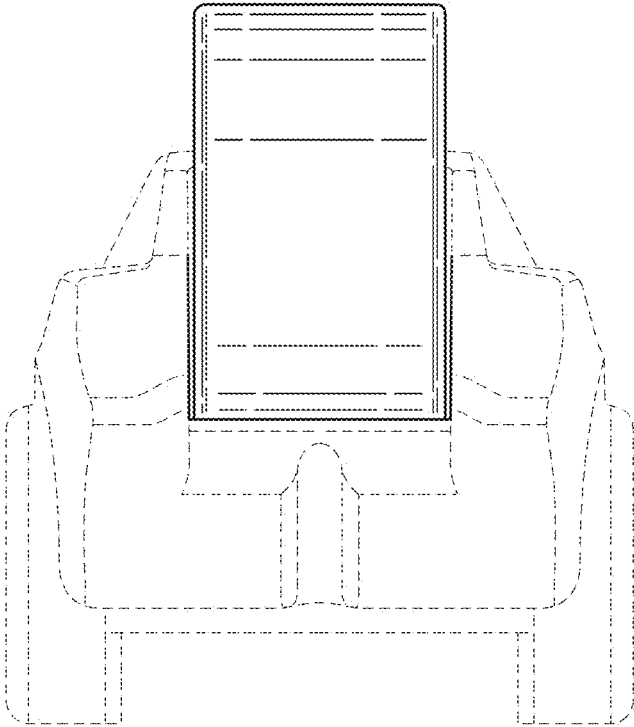

FIG. 3

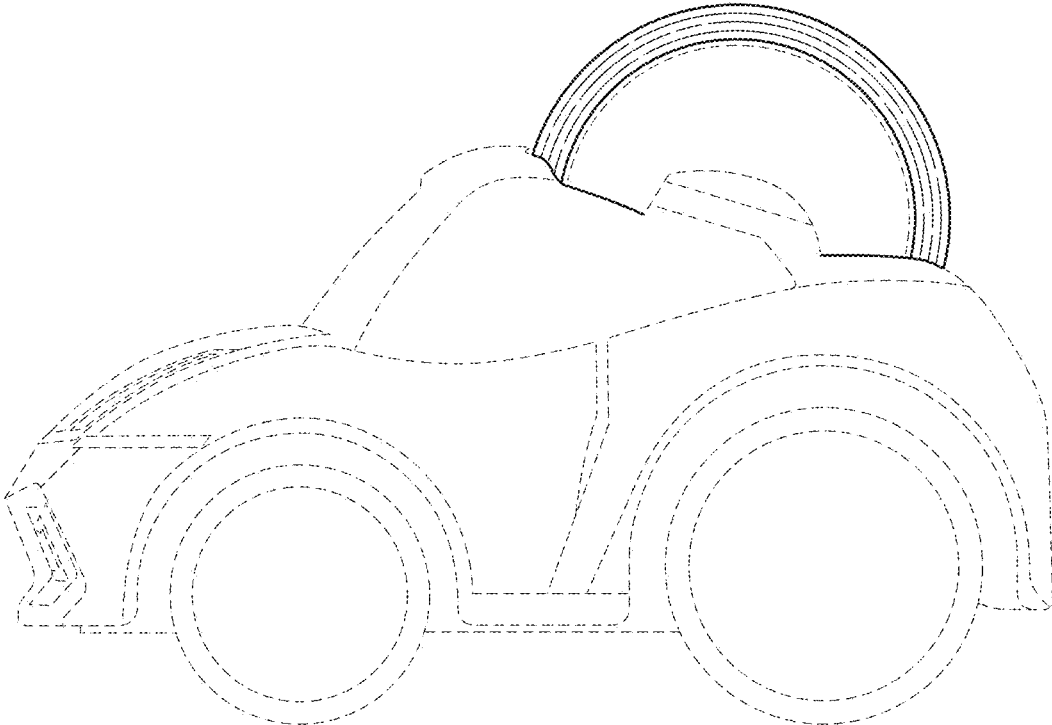

FIG. 4

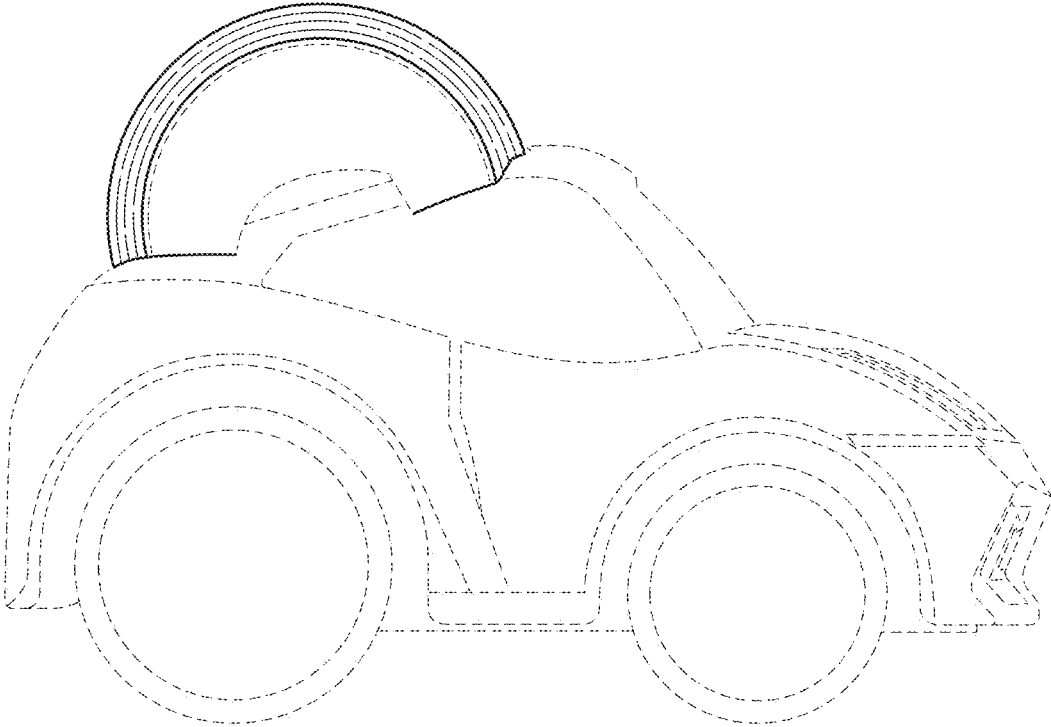

FIG. 5

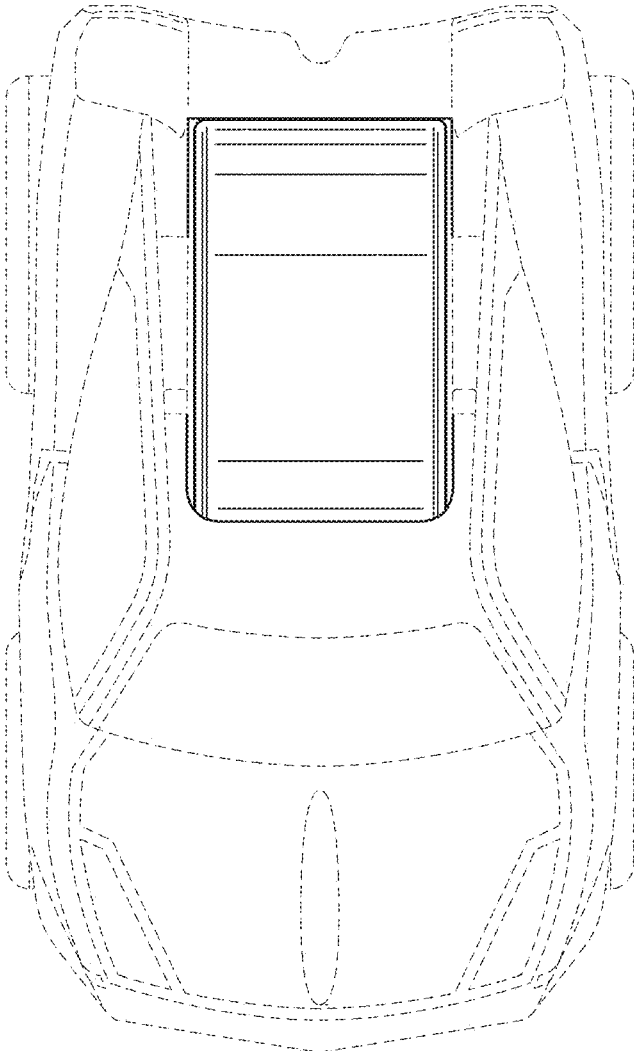

FIG. 6

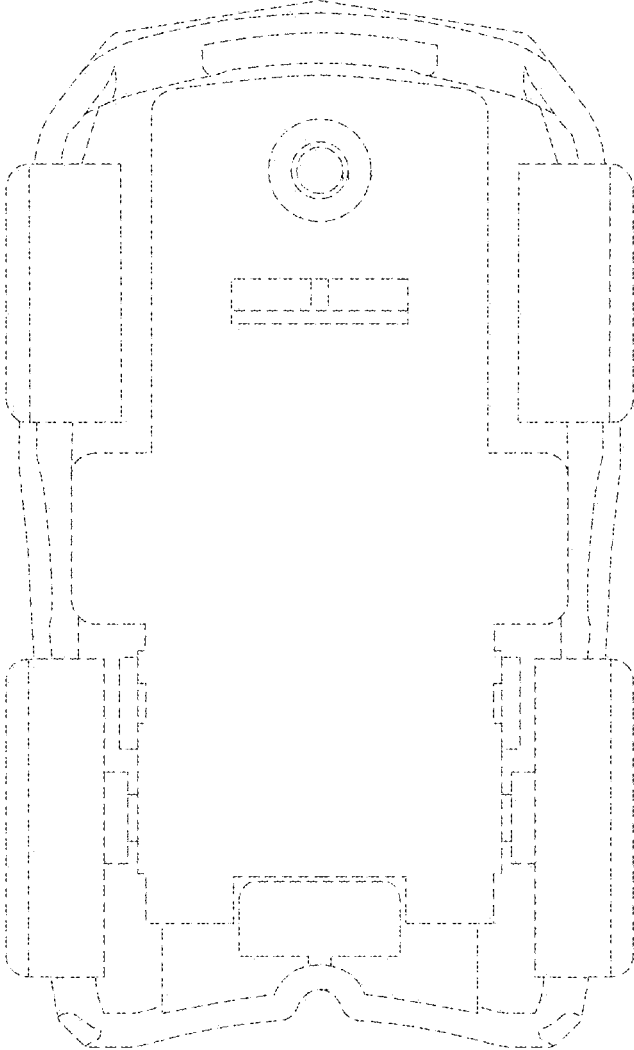

FIG. 7

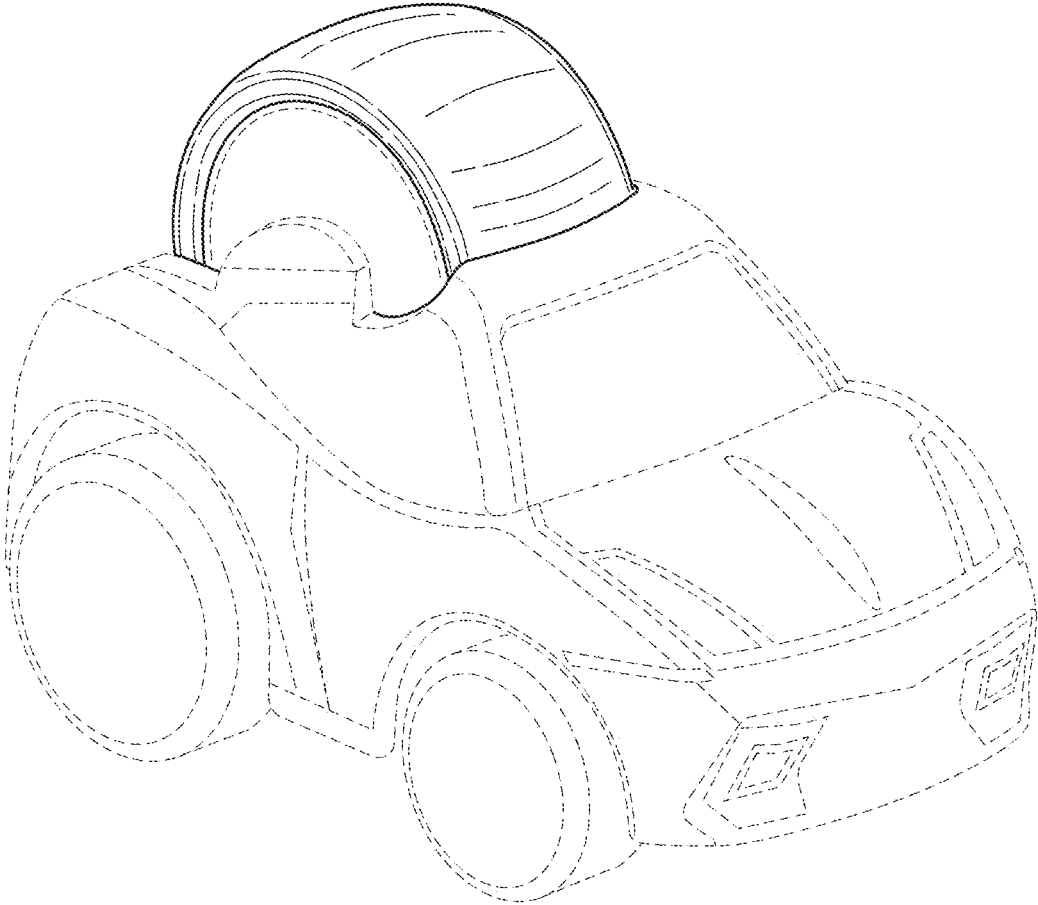

FIG. 8

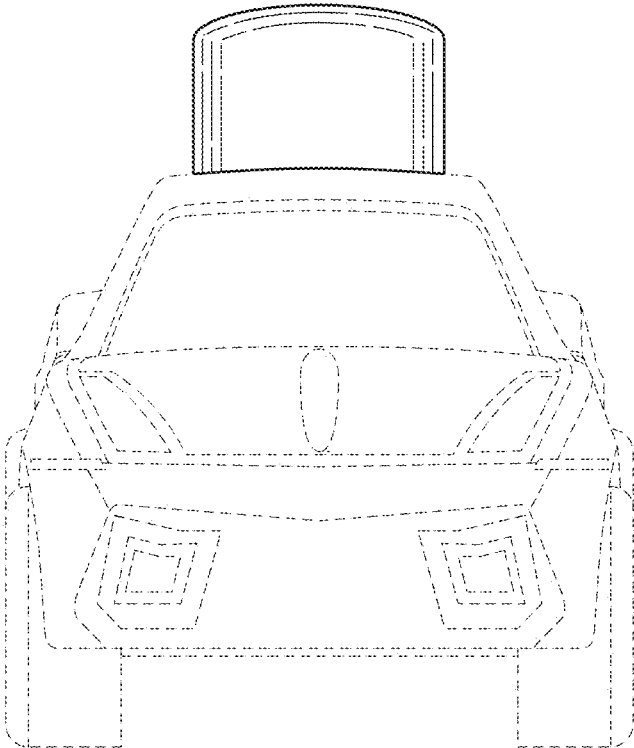

FIG. 9

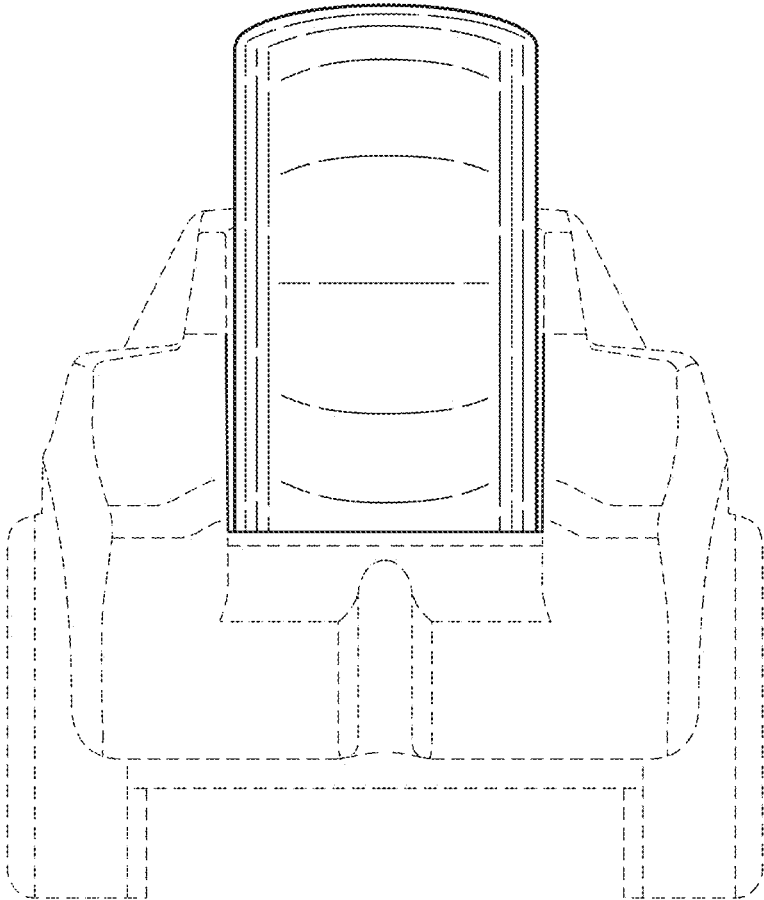

FIG. 10

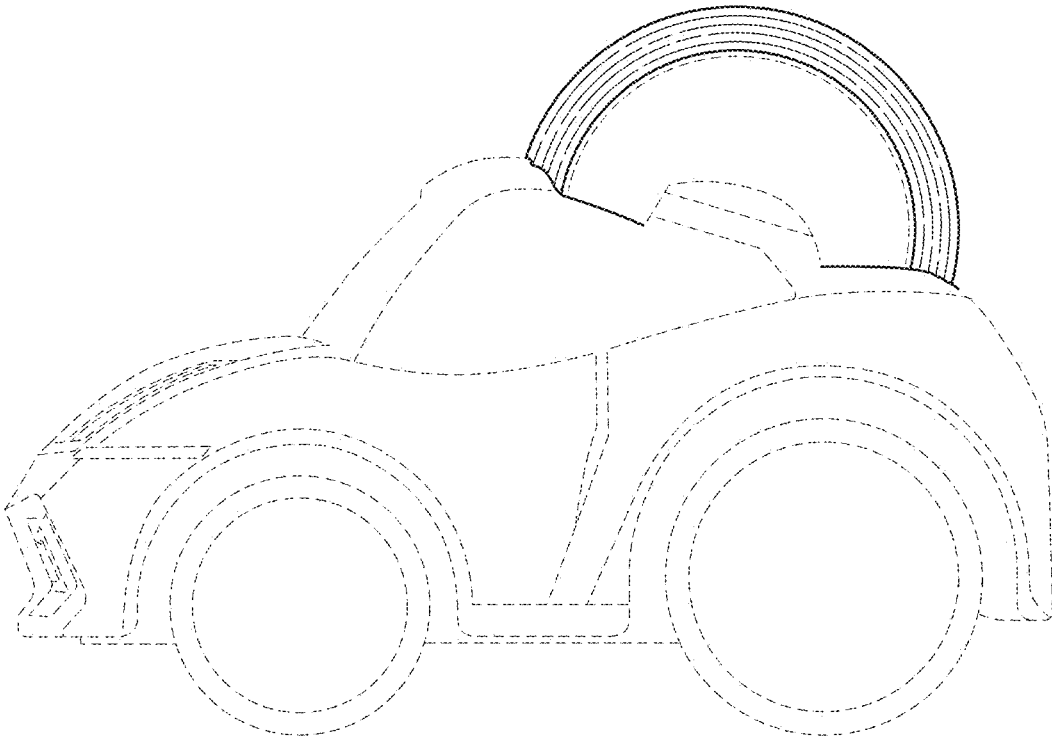

FIG. 11

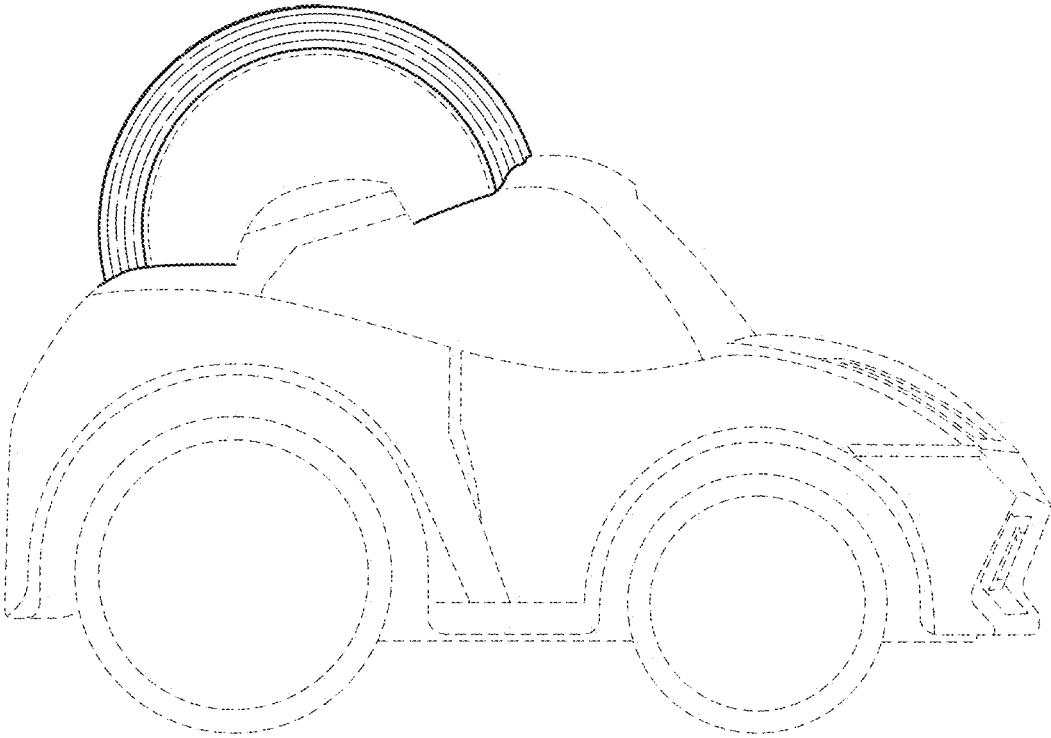

FIG. 12

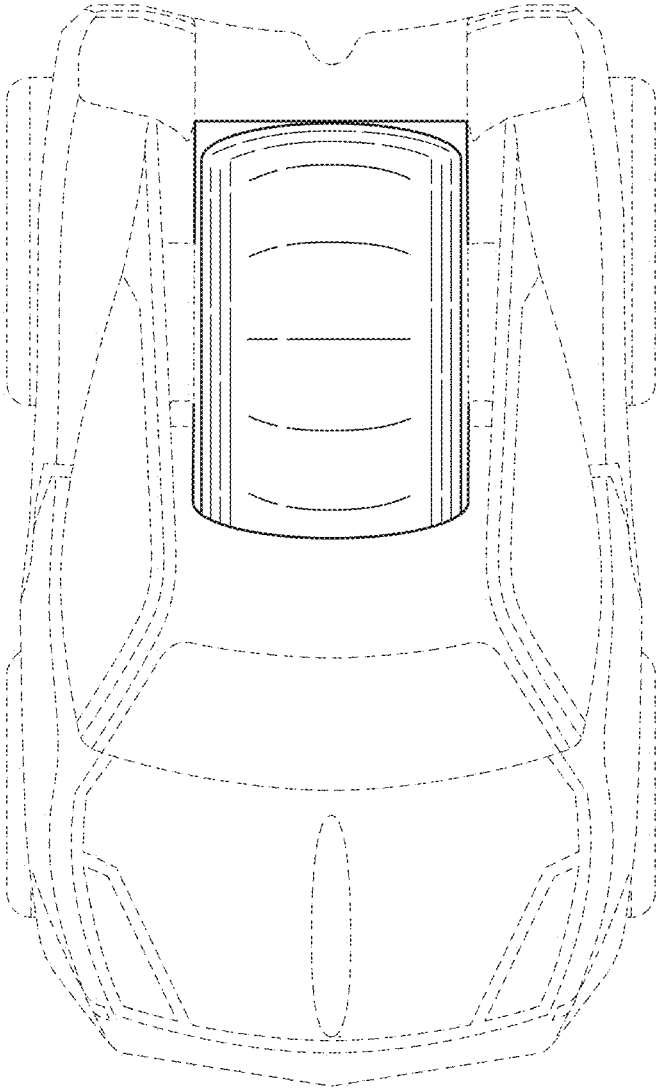

FIG. 13

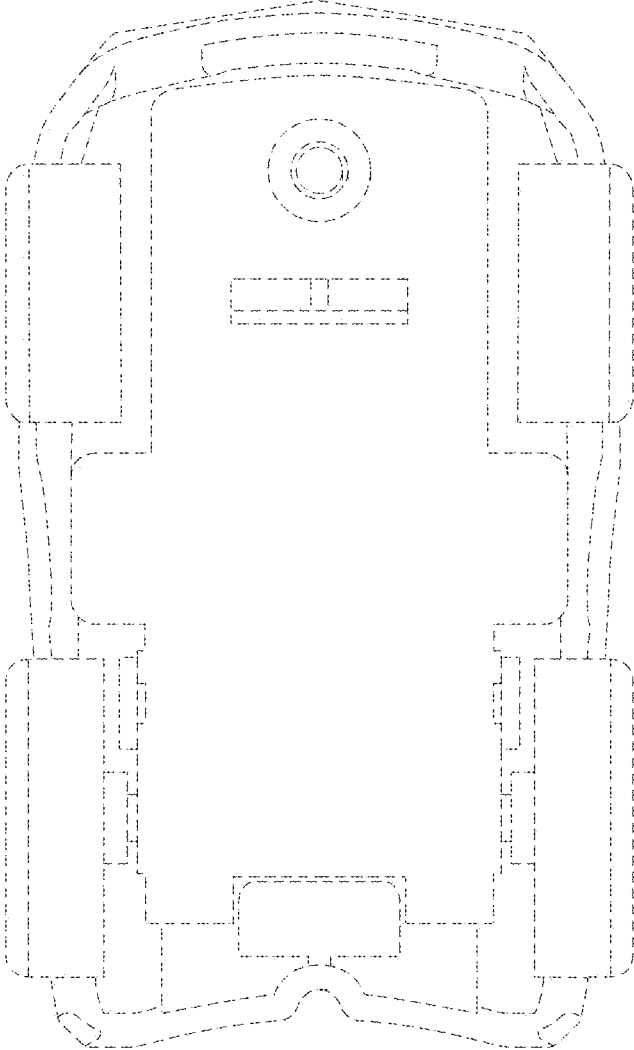

FIG. 14

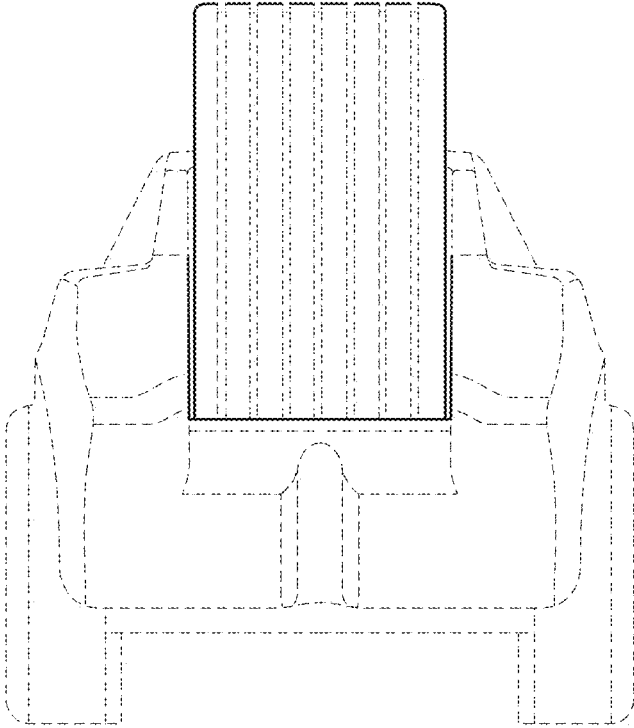

FIG. 15

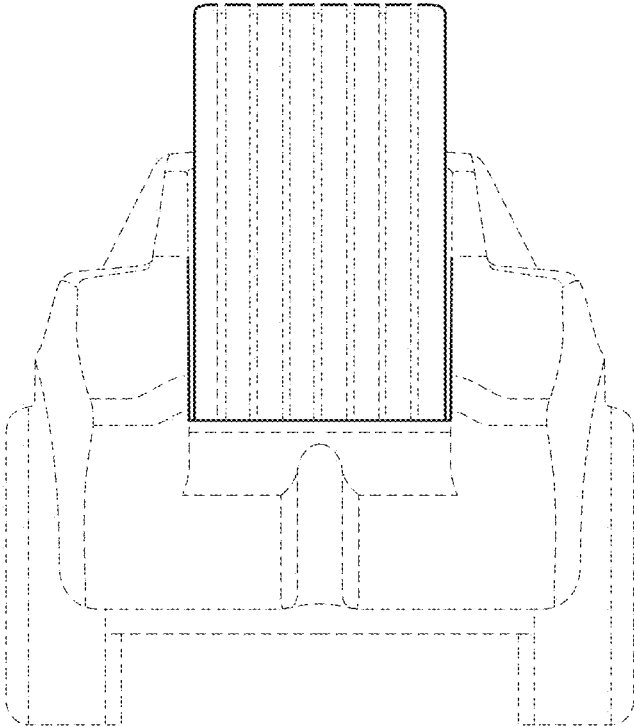

FIG. 16

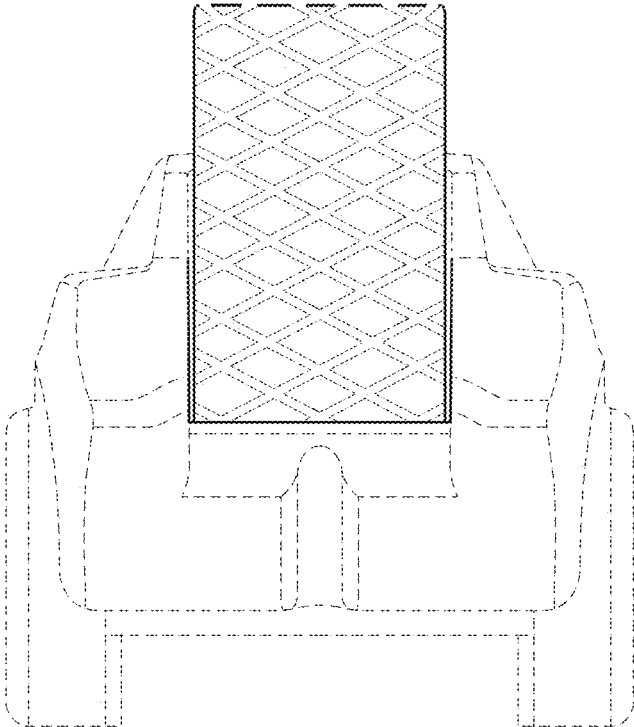

FIG. 17

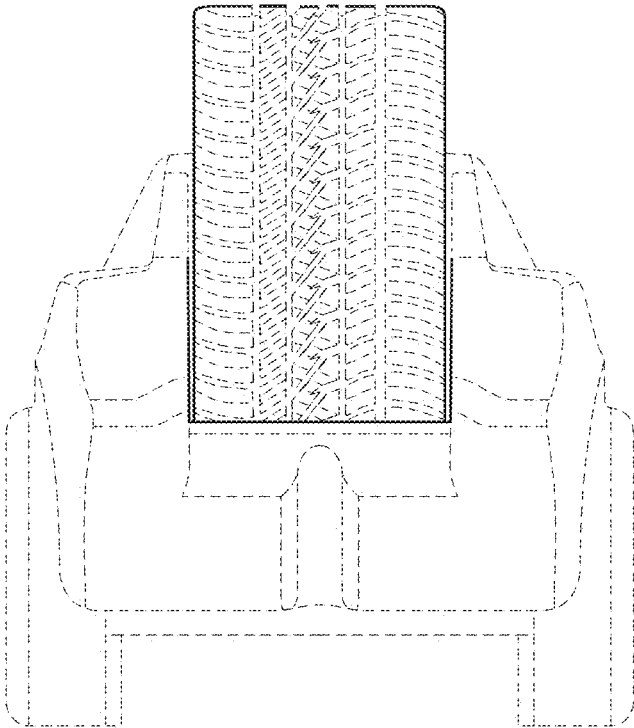

FIG. 18

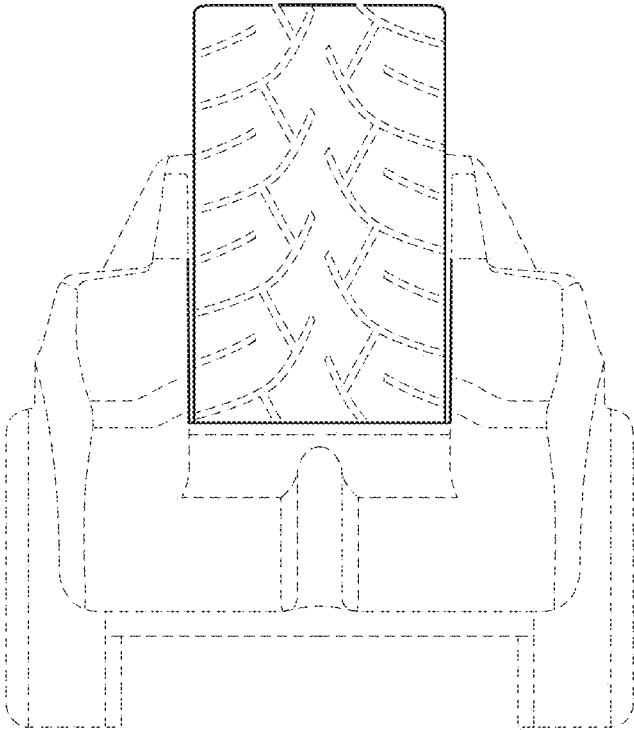

FIG. 19

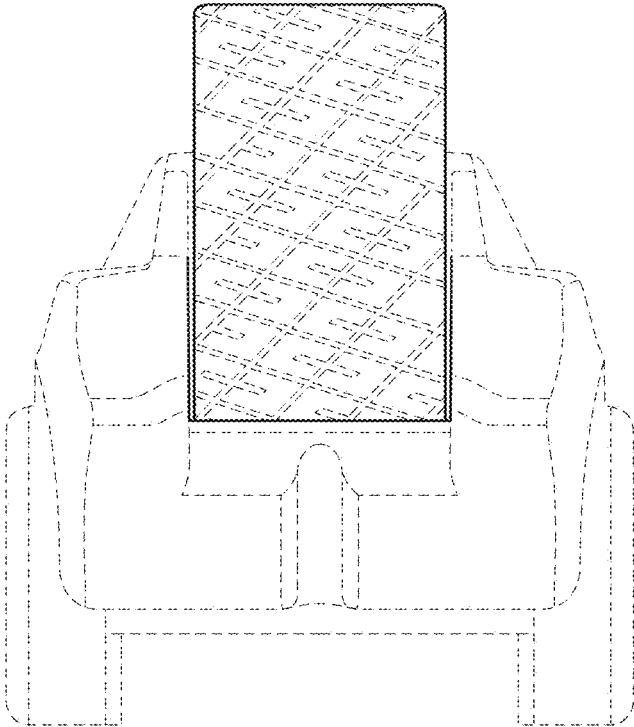

FIG. 20

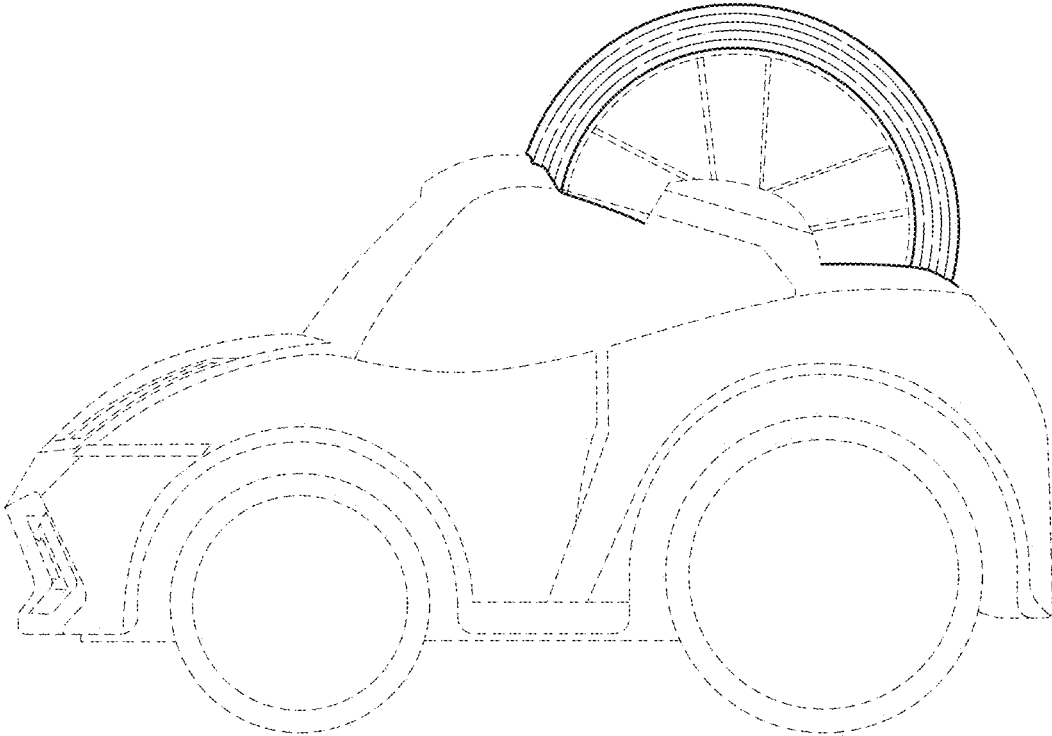

FIG. 21

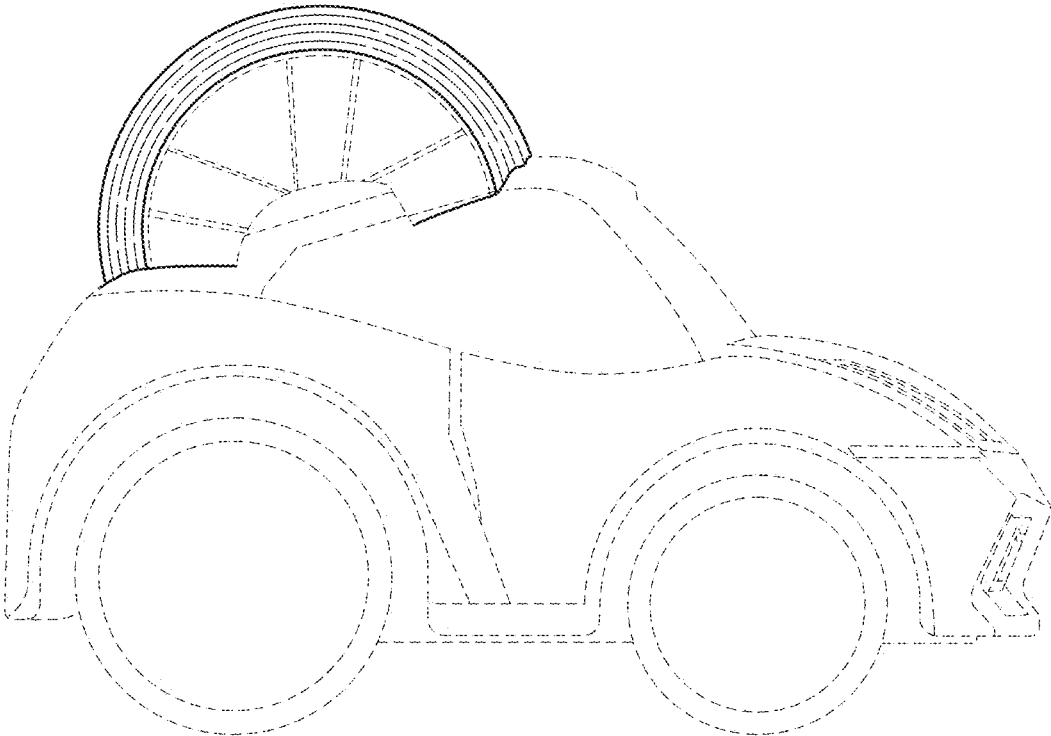

FIG. 22